



AMERICAN COOLAIR CORPORATION



Centrifugal Upblast Power Roof Ventilators

TYPE CUBA - BELT DRIVE
TYPE CUDA - DIRECT DRIVE

CUBA

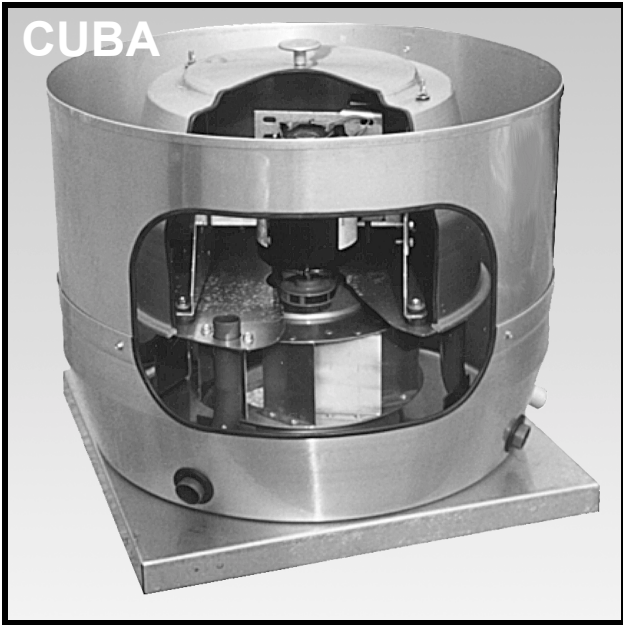

**Sizes 12 to 24
781 to 8850 CFM
Static Pressure to 2”
AMCA Licensed Ratings for
Sound and Air**

TABLE OF CONTENTS

BELT DRIVE FANS

CUBA

- Dimensional Data 3
- ILG’s “C-Drive” 4
- Fan Description 5
- Performance 12 6
- Performance 13 7
- Performance 15 8
- Performance 16 9
- Performance 18 10
- Performance 21 11
- Performance 24 12

CUDA

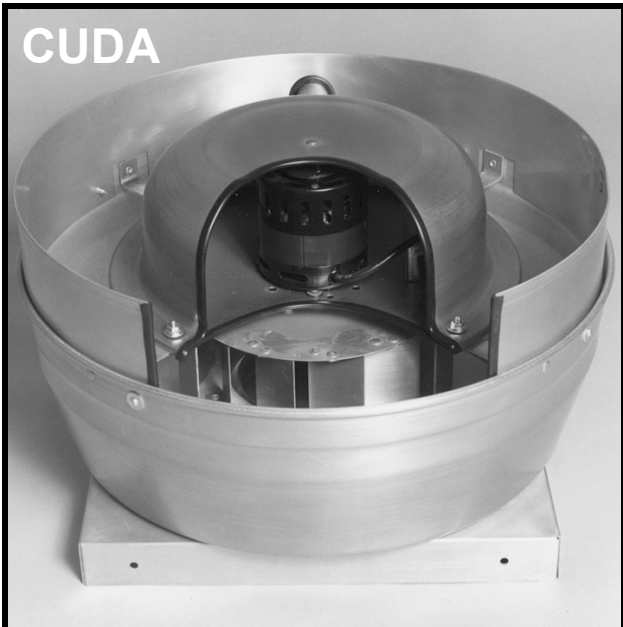

**Sizes 06 to 20
133 to 4942 CFM
Static Pressure to 1”
AMCA Licensed Ratings for
Sound and Air**

DIRECT DRIVE FANS

CUDA

- Dimensional Data 13
- Fan Description 14
- Performance 06-10 15
- Performance 12-13 16
- Performance 15-20 17
- Installation & Maintenance 18
- Options & Accessories 19
- Specification Checklist 20

FEATURES

CUBA Units

Belt drive with adjustable motor pulley provides flexibility to match operating requirements.

Single bolt adjustment facilitates tensioning of belt.

Weather-resistant motor compartment cover of spun aluminum removes easily for access to motor and drive.

Out-of-airstream open drip-proof motors are isolated for protection from exhaust airstream.

Overlapping wheel and deep-spun venturi minimize noise and air turbulence, increasing efficiency.

Aluminum centrifugal wheel is a non-overloading, backward-inclined design and is computer balanced.

Permanently affixed wheel balance weights assure vibration-free operation.

Wheel backplate fins cool the motor compartment, extending motor life.

Safety disconnect switch is optional.

AMCA Seal assures certified rating of air and sound performance.

UL Listed for Standard 705 or Standard 762.

CUBA

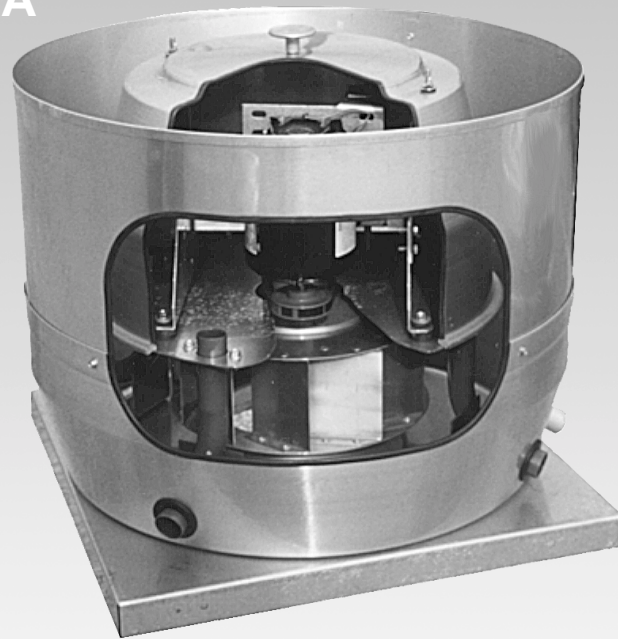

CUBA Ventilator, Roof Curb, and Damper Dimensions

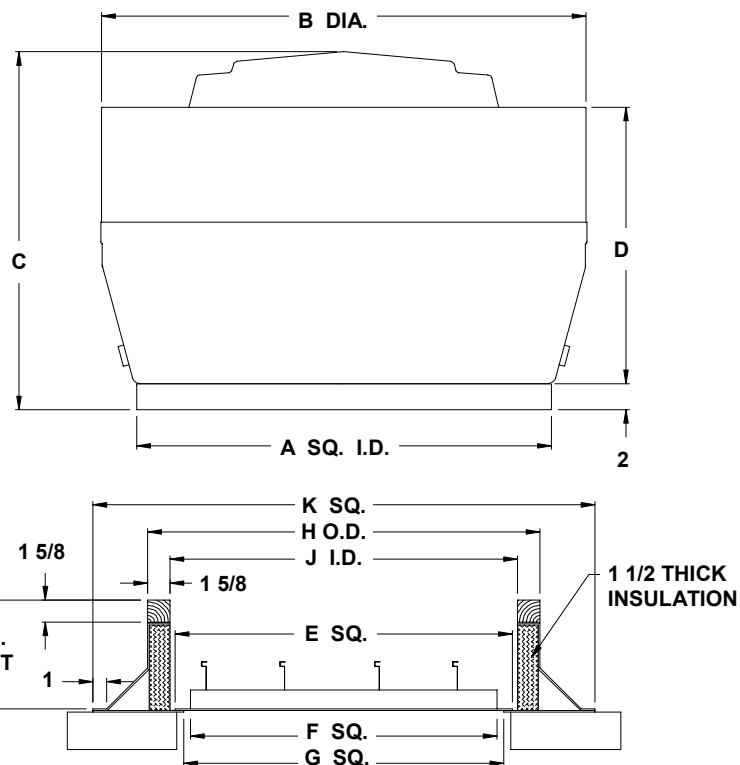

Size	Ventilator Dimensions				Roof Curb and Damper Dimensions					
	A	B	C	D	E	F	G	H	J	K
12-15	26	29 1/4	24 1/2	22	20 1/2	18	19 1/4	24 1/2	21 1/4	32 1/2
16-18	30	35 1/4	26 3/8	22	24 1/2	22	23 1/4	28 1/2	25 1/4	36 1/2
21	34	43	30	25 1/2	28 1/2	26	27 1/4	32 1/2	29 1/4	40 1/2
24	34	43	34 5/8	25 1/2	28 1/2	26	27 1/4	32 1/2	29 1/4	40 1/2

Dimensions in inches

ILG's "C-Drive"

Available Exclusively on CUBA Units Sizes 12 - 24

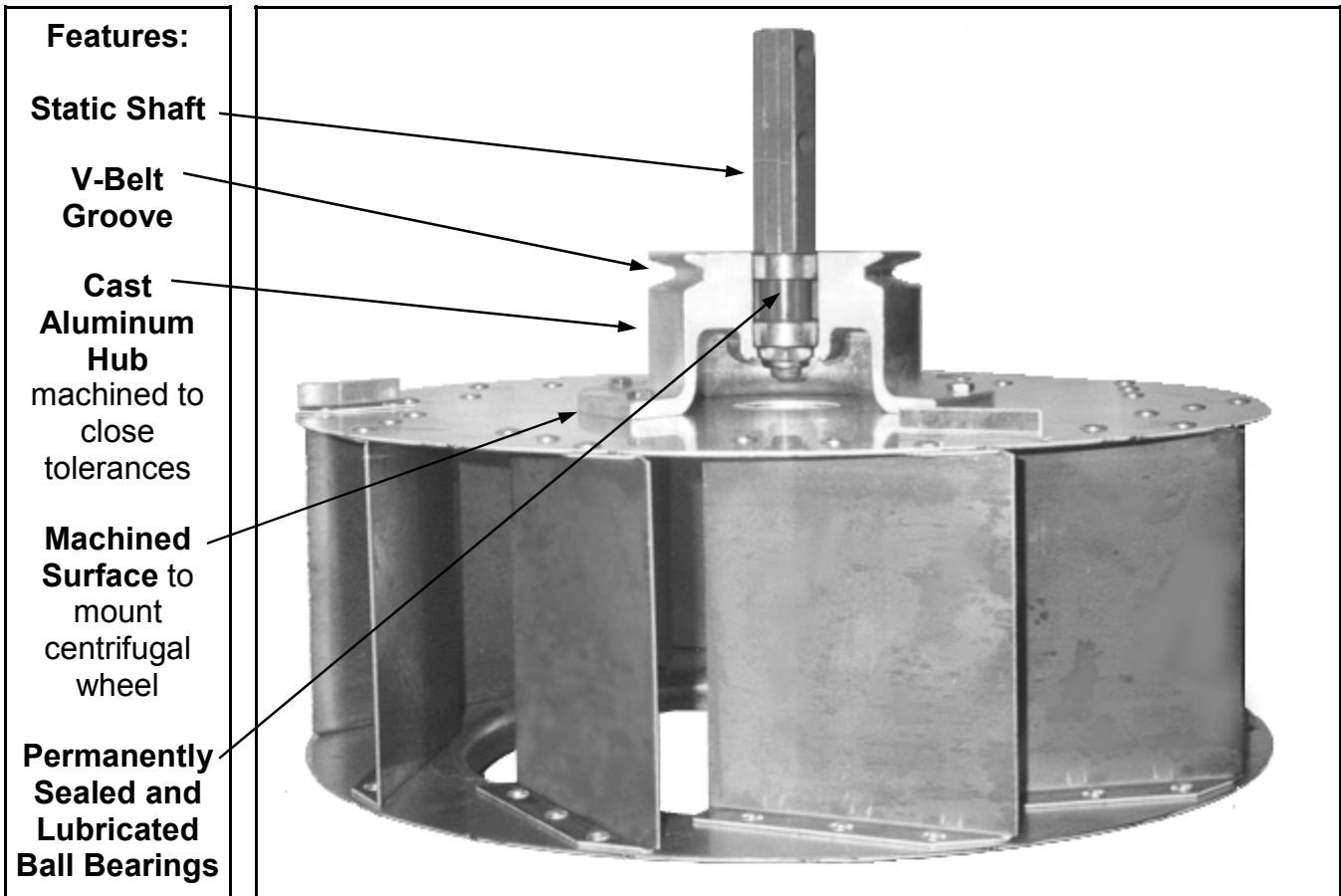
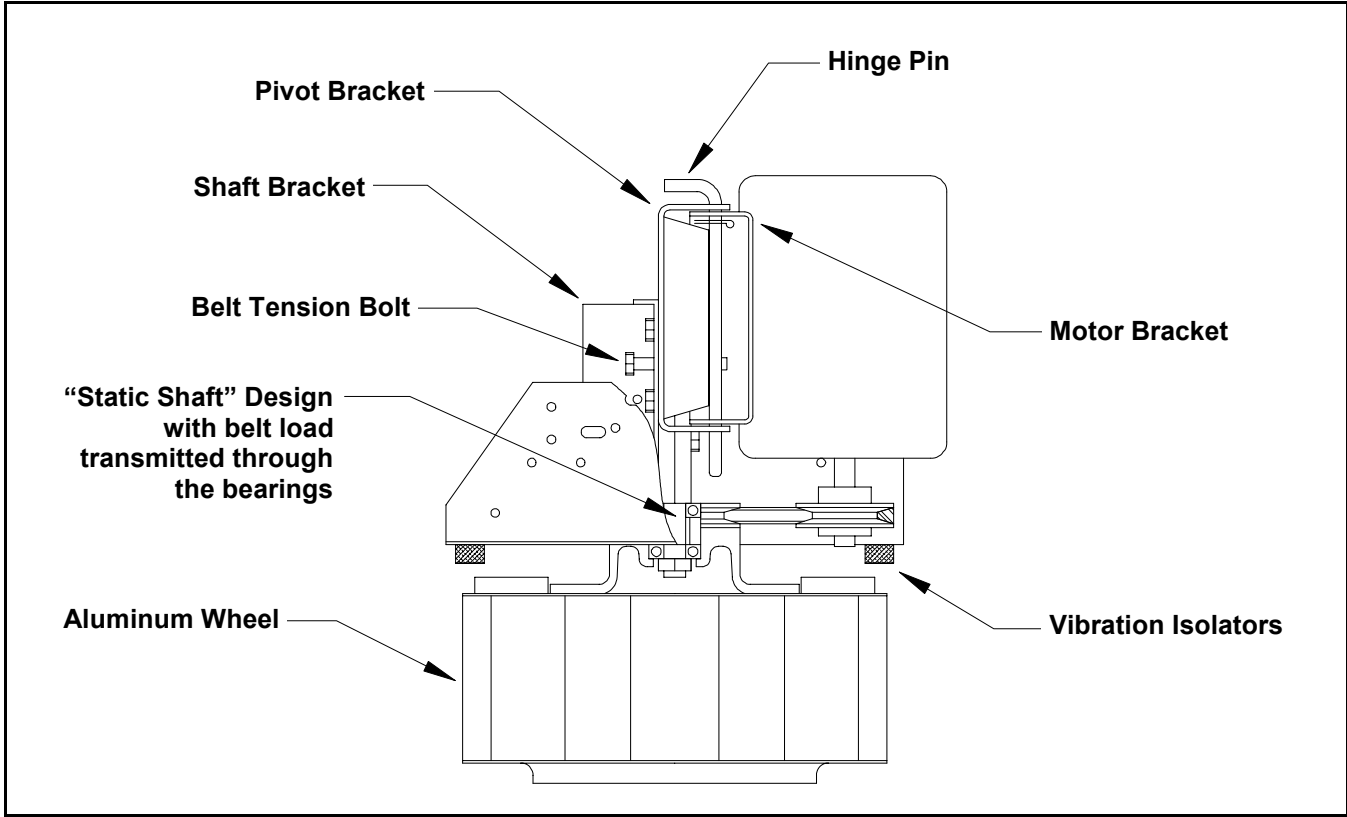

CUBA

Belt Drive Centrifugal Upblast Power Roof Ventilators

Applications

The CUBA units are quiet, dependable upblast power roof ventilators for the removal of grease-laden air from kitchen exhaust systems, and general ventilation applications where vertical discharge of exhaust air is required. Applications include virtually all types of commercial and institutional kitchens, such as restaurant and cafeteria, fast food, hospital, hotel and motel, bakery, delicatessen, school and military.

The advantages of a CUBA belt drive over a direct drive roof ventilator include quieter operation, adjustable performance to suit operating needs and extended service life using the "C-Drive" bearing arrangement.

The CUBA meets the rigorous requirements of Underwriters Laboratories Standard 762 and is so listed as being suitable for the extraction of grease-laden air and fumes from range exhaust hoods and commercial kitchen exhaust systems. When properly installed, the CUBA also meets the requirements of NFPA 96. It is particularly recommended for economical and efficient range hood ventilation where continuous operation under severe conditions may cause other power roof ventilators to fail.

Construction

CUBA models feature a housing of durable spun aluminum for optimum weather protection. The overlapping deep-spun venturi minimizes air turbulence, and increases efficiency.

The aluminum centrifugal wheel is a non-overloading, backward-inclined type, selected for low noise levels. Backplate fins draw cool air through the motor compartment. The wheel is secured to the machined aluminum "C-Drive" disc, and computer balanced on state-of-the-art equipment.

Neoprene vibration isolators to reduce noise and wear are standard.

Drive Mechanism

The belt driven CUBA utilizes a unique bearing/shaft arrangement that has been designated the "C-Drive". This "C-Drive" is patterned after American Coolair's unique static shaft drive design that has been in existence for over seventy years serving the general ventilation markets with reliable propeller products. This type of drive uses a captured bearing arrangement inside a cast aluminum disc assembly locked to a short, large-diameter shaft. The shaft is held stationary and the centrifugal wheel/disc assembly rotates on the shaft instead of the entire assembly rotating.

This design accomplishes several identifiable points of value. As a result of reduction of radial loading of the bearings, the calculated L10 bearing life exceeds 1,000,000 hours or an average bearing life of 5,000,000 hours. Most other manufacturers' turning shaft drive designs result in a cataloged average bearing life of 150,000-200,000 hours. Additionally, the machined surface of the "C-Drive" provides a rigid backplate for the centrifugal wheel. Electrical connections on the end of the motor face upwards making field connections rapid and simple. This compact drive assembly provides more room in the motor compartment area and the single bolt, V-belt adjustment makes for a very serviceable unit.

Motors

The standard motor for CUBA models is open drip-proof construction, located out of the airstream. Totally enclosed, energy efficient, two-speed and explosion-proof motors may also be available. All motor brands are recognized and serviced nationwide. Motor enclosure may affect UL Listing.



UL705 - E39944

Type CUBA ventilators are UL705 Listed by Underwriters Laboratory Inc. to US and Canadian safety standards.



UL762 - MH9847

Type CUBA ventilators are UL762 Listed by Underwriters Laboratory Inc. to US safety standards.



American Coolair Corporation, ILG Industries certifies that the Type CUBA units shown herein are licensed to bear the AMCA Seal. The ratings shown are based on tests and procedures performed in accordance with AMCA Publication 211 and AMCA Publication 311 and comply with the requirements of the AMCA Certified Ratings Program.

Guide Specifications

Upblast power roof ventilators shall be of the CUBA centrifugal type as manufactured by ILG Industries of American Coolair Corporation (individual models to be listed in fan schedule). Units shall meet UL Standard 705 or 762 as required and shall bear the AMCA Certified Ratings Seal for air and sound performance. Housing and venturi inlet shall be one piece heavy gauge spun aluminum with wheel and venturi overlapping for efficient operation. Motor compartment cover shall be heavy gauge spun aluminum construction and easily removable for access to motor and drive. Base, motor compartment disc and support pipes shall be heavy gauge steel.

Drive construction shall be of the ILG "C-Drive" design consisting of static shaft/bearing arrangement mounted in a machined cast aluminum disc assembly. The disc assembly shall be mounted onto the backplate of the centrifugal wheel. The centrifugal wheel shall be heavy gauge aluminum with backward-inclined, non-overloading blades and be computer balanced.

Bearings shall have a calculated L10 bearing life in excess of 1,000,000 hours.

Motor shall be open drip-proof construction, NEMA design B with minimum service factor of 1.15. Adjustable motor pulley shall be provided to allow for field adjustment and system balance. Motor shall be mounted on a steel mounting bracket with single bolt adjustment. Motor shall be mounted with the shaft down to allow easy access to the electrical wiring terminal board/circuit box.

(Safety disconnect switch, backdraft damper, epoxy coating, roof curb and other accessories shall be listed in the fan schedule).

CUBA15 Performance Data

CFM at Static Pressure																			RPM Range Motor HP				RPM		
0.00		.125		.250		.375		.500		.750		1.00		1.25		1.50		2.00		1/3	1/2	3/4		1	
BHP	Sone	BHP	Sone	BHP	Sone	BHP	Sone	BHP	Sone	BHP	Sone	BHP	Sone	BHP	Sone	BHP	Sone	BHP	Sone	BHP	Sone				
2188		2101		1967		1835		1722		1395															1119
0.27	10.1	0.29	9.4	0.31	9.5	0.32	9.2	0.33	8.5	0.33	8.2														
2280		2197		2077		1939		1835		1533															1166
0.31	10.8	0.33	10.2	0.35	10.3	0.36	10.1	0.37	9.3	0.38	9.1														
2370		2291		2183		2041		1940		1667		1361													1212
0.35	11.6	0.37	10.9	0.39	11.0	0.40	10.9	0.42	10.3	0.42	9.8	0.42	9.4												
2462		2386		2288		2148		2045		1804		1512													1259
0.39	12.5	0.41	11.8	0.43	11.8	0.45	11.8	0.46	11.3	0.48	10.5	0.47	10.0												
2552		2479		2388		2255		2147		1937		1649													1305
0.44	13.4	0.46	12.7	0.48	12.6	0.50	12.7	0.51	12.3	0.53	11.2	0.53	11.1												
2644		2574		2489		2365		2251		2062		1787		1511											1352
0.48	14.3	0.50	13.6	0.53	13.5	0.55	13.6	0.56	13.4	0.59	12.1	0.59	12.3	0.59	11.8										
2736		2668		2589		2476		2356		2179		1923		1664											1399
0.54	15.4	0.56	14.5	0.58	14.3	0.60	14.5	0.62	14.4	0.65	13.2	0.65	13.3	0.65	12.4										
2826		2761		2686		2583		2460		2286		2058		1802		1514									1445
0.59	16.3	0.61	15.6	0.63	15.3	0.66	15.4	0.68	15.5	0.71	14.3	0.72	14.0	0.72	13.7	0.70	14.0								
2917		2854		2784		2690		2569		2393		2194		1940		1693									1492
0.65	17.4	0.67	16.6	0.70	16.3	0.72	16.4	0.74	16.5	0.78	15.6	0.79	14.7	0.79	15.0	0.79	14.2								
3009		2948		2881		2795		2679		2498		2323		2077		1842									1539
0.72	18.4	0.74	17.6	0.76	17.3	0.78	17.3	0.81	17.5	0.85	16.9	0.87	15.7	0.87	16.2	0.87	15.2								
3099		3040		2976		2896		2788		2600		2442		2211		1981									1585
0.78	19.5	0.80	18.7	0.83	18.3	0.85	18.3	0.88	18.4	0.92	18.1	0.94	16.8	0.95	17.0	0.95	16.6								
3191		3134		3072		2998		2898		2704		2555		2349		2119									1632
0.85	21	0.88	19.8	0.90	19.3	0.93	19.3	0.95	19.4	1.00	19.3	1.03	18.1	1.04	17.7	1.03	17.9								
3281		3225		3166		3096		3004		2806		2662		2481		2252		1790							1678
0.93	22	0.95	21	0.98	20	1.00	20	1.03	21	1.08	21	1.11	19.4	1.13	18.5	1.12	19.1	1.11	18.7						

Performance shown is for Type A: free inlet, free outlet. Performance ratings do not include the effects of appurtenances in the airstream.
 Power ratings (BHP) do not include drive losses. Bearing losses are included.
 The sound ratings shown are loudness values in fan sones at 5 ft. (1.5 m) in a hemispherical free field calculated per AMCA Standard 301. Values shown are for installation Type A: free inlet fan sone levels.

CUBA21 Performance Data

CFM at Static Pressure																		RPM Range					RPM		
0.00		.125		.250		.375		.500		.750		1.00		1.25		1.50		2.00		1/2	3/4	1		1 1/2	2
BHP	Sone	BHP	Sone	BHP	Sone	BHP	Sone	BHP	Sone	BHP	Sone	BHP	Sone	BHP	Sone	BHP	Sone	BHP	Sone						
3857		3620		3383		3189		2931		2092															771
0.41	10.8	0.43	9.8	0.45	9.4	0.46	9.1	0.47	8.6	0.43	7.3														807
4037		3812		3580		3390		3185		2485															844
0.47	11.6	0.49	10.7	0.51	10.2	0.52	10.0	0.54	9.6	0.52	8.6														881
4222		4008		3783		3594		3415		2801															918
0.53	12.5	0.56	11.5	0.58	11.1	0.59	11.0	0.61	10.7	0.61	10.1														954
4407		4203		3986		3797		3630		3091		2295													991
0.61	13.5	0.64	12.5	0.66	12.0	0.67	12.1	0.69	11.9	0.70	11.4	0.63	9.8												1028
4593		4397		4189		3999		3838		3383		2733													1080
0.69	14.5	0.72	13.4	0.74	12.9	0.76	13.1	0.77	13.1	0.80	12.3	0.76	11.1												1117
4773		4585		4385		4196		4037		3662		3066													1154
0.77	15.6	0.80	14.4	0.83	14.0	0.84	14.1	0.86	14.2	0.89	13.4	0.88	12.8												1191
4958		4778		4586		4399		4240		3918		3365		2645											1229
0.86	16.7	0.90	15.6	0.92	15.1	0.94	15.1	0.96	15.3	0.99	14.7	0.99	14.3	0.91	12.6										1266
5143		4970		4785		4603		4443		4149		3653		3073											1303
0.96	17.8	1.00	16.7	1.03	16.2	1.05	16.2	1.07	16.4	1.10	15.9	1.11	15.5	1.07	14.2										
5403		5239		5064		4888		4727		4451		4065		3539		2824									
1.12	19.4	1.16	18.3	1.19	17.8	1.21	17.7	1.23	17.8	1.27	17.8	1.30	17.0	1.28	16.6	1.16	15.1								
5588		5430		5262		5090		4930		4660		4339		3833		3270									
1.24	20	1.28	19.5	1.31	18.9	1.33	18.7	1.35	18.9	1.39	19.0	1.43	18.2	1.42	17.9	1.35	16.6								
5773		5620		5459		5292		5133		4865		4586		4121		3631									
1.36	22	1.41	21	1.44	20	1.47	19.8	1.49	20	1.53	20	1.57	19.6	1.58	19.2	1.54	18.4								
5958		5810		5655		5493		5336		5069		4814		4415		3941		2338							
1.50	23	1.54	22	1.58	21	1.61	21	1.63	21	1.67	22	1.71	21	1.74	20	1.72	20	1.36	18.8						
6148		6005		5855		5699		5545		5277		5036		4708		4240		3006							
1.65	24	1.69	23	1.73	23	1.76	22	1.78	22	1.83	23	1.87	23	1.91	22	1.90	21	1.66	19.4						
6333		6194		6049		5898		5748		5479		5247		4969		4529		3503							
1.80	25	1.85	24	1.89	24	1.92	23	1.94	23	1.99	24	2.04	24	2.08	23	2.08	22	1.92	21						
6519		6384		6243		6097		5950		5682		5454		5209		4823		3914							
1.96	26	2.01	25	2.05	24	2.09	24	2.11	24	2.16	25	2.21	25	2.25	24	2.27	23	2.18	22						

Performance shown is for Type A: free inlet, free outlet. Performance ratings do not include the effects of appurtenances in the airstream.

Power ratings (BHP) do not include drive losses. Bearing losses are included.

The sound ratings shown are loudness values in fan sones at 5 ft. (1.5 m) in a hemispherical free field calculated per AMCA Standard 301. Values shown are for installation Type A: free inlet fan sone levels.

FEATURES

CUDA Units

Safety disconnect device is standard.

Direct drive assembly reduces maintenance and operating costs.

Line bore hub eliminates the need for a bushing, and has wheel puller provisions

Weather-resistant motor compartment cover of spun aluminum removes easily for access to motor and drive.

Out-of-airstream open motors are isolated for protection from exhaust airstream.

Overlapping wheel and deep-spun venturi minimize noise and air turbulence, increasing efficiency.

Aluminum centrifugal wheel is a non-overloading, backward-inclined design and is computer balanced.

Permanently affixed wheel balance weights assure vibration-free operation.

Wheel backplate fins cool the motor compartment, extending motor life.

AMCA Seal assures certified rating of air and sound performance.

UL Listed for Standard 705.

CUDA

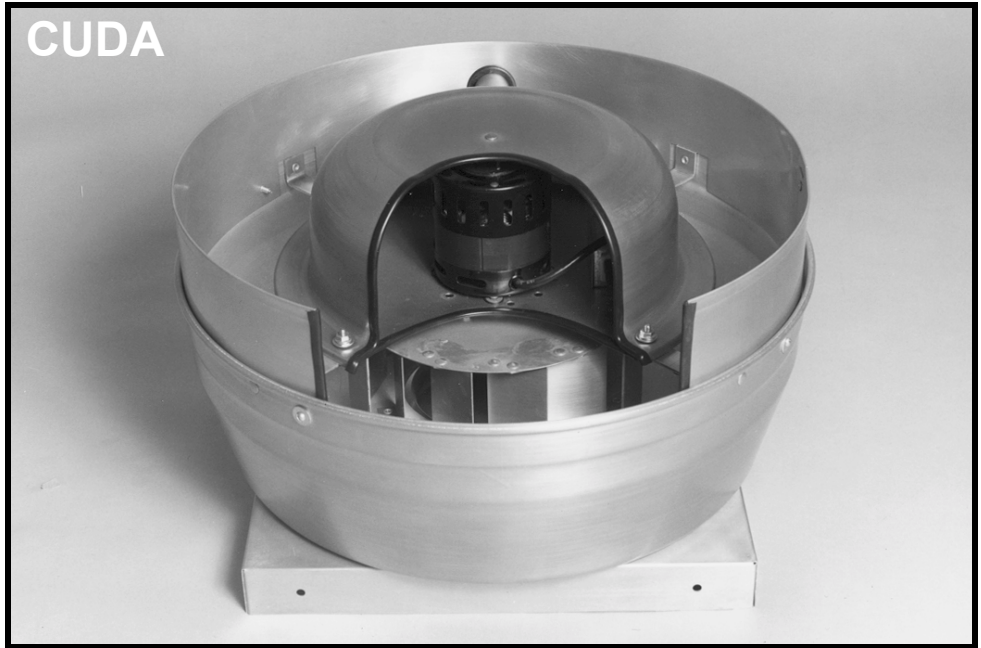

CUDA Ventilator, Roof Curb and Damper Dimensions

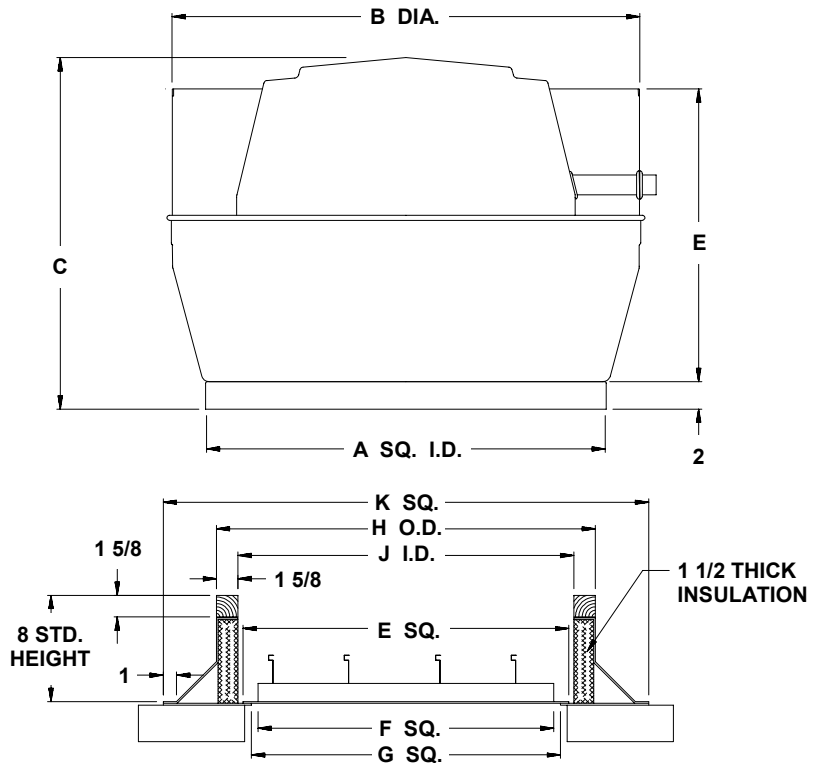

Unit	Ventilator Dimensions				Roof Curb and Damper Dimensions					
	A	B	C	D	E	F	G	H	J	K
06-10	18	23	14 1/8	11 1/8	12 1/2	10	11 1/4	16 1/2	13 1/4	24 1/2
12E10,12J16 13F11,13J15 15H10,15K15	26	29 1/4	19	22	20 1/2	18	19 1/4	24 1/2	21 1/4	32 1/2
12J17,13K17 15L17	26	29 1/4	24 1/4	22	20 1/2	18	19 1/4	24 1/2	21 1/4	32 1/2
16-20	30	35 1/4	26 3/8	22	24 1/2	22	23 1/4	28 1/2	25 1/4	36 1/2

Dimensions in inches

CUDA

Direct Drive Centrifugal Upblast Power Roof Ventilators

Applications

The CUDA units are quiet, dependable upblast power roof ventilators recommended for a wide range of general exhaust applications where low and medium ranges of air volume and pressure are specified. Applications include virtually all types of light manufacturing, commercial and institutional buildings such as shopping centers, hospitals, schools, hotels, office and apartment buildings, warehouses, airports, bus terminals and many others.

CUDA units are specified where vertical discharge of exhaust air is desired to eliminate interference with other equipment or activities in the building. They permit the direct upward venting of overheated air. CUDA units may be used with or without ducts.

The advantages of a CUDA direct drive over a belt drive roof ventilator include lower maintenance requirements, reduced risks of lower performance levels as a result of loosened belts, and lower operating costs.

Construction

CUDA models feature a housing of durable spun aluminum for optimum weather protection. The overlapping deep-spun venturi minimizes air turbulence and increases efficiency.

The aluminum centrifugal wheel is a non-overloading, backward-inclined type, selected for low noise levels. Backplate fins draw cool air through the motor compartment. The wheel is secured to the machined aluminum hub, and computer balanced on state-of-the-art equipment. The hub features a line bore, which eliminates the need for bushings.

Neoprene vibration isolators to reduce noise and wear and a safety disconnect device with a mounted and wired junction box are all standard.

Drive Mechanism

CUDA models have all the advantages of a direct drive assembly. There are no belts, bearings or pulleys to consume power or require maintenance.

Motors

The standard motor for CUDA models is open construction, located out of the airstream. Totally enclosed, energy efficient, two-speed and explosion-proof motors may also be available. All motor brands are recognized and serviced nationwide. Motor enclosure may affect UL Listing.



UL705 - E39944

Type CUDA ventilators are Listed by Underwriters Laboratory Inc. to US and Canadian safety standards.



American Coolair Corporation, ILG Industries certifies that the Type CUBA units shown herein are licensed to bear the AMCA Seal. The ratings shown are based on tests and procedures performed in accordance with AMCA Publication 211 and AMCA Publication 311 and comply with the requirements of the AMCA Certified Ratings Program.

Guide Specifications

Upblast power roof ventilators shall be of the CUDA centrifugal type as manufactured by ILG Industries of American Coolair Corporation (individual models to be listed in fan schedule). Units shall meet UL Standard 705 and shall bear the AMCA Certified Ratings Seal for air and sound performance. Housing and venturi inlet shall be one piece heavy gauge spun aluminum with wheel and venturi overlapping for efficient operation. Motor compartment cover shall be heavy gauge spun aluminum construction and easily removable for access to motor.

Drive construction shall be of the direct drive design. The line bore hub shall be mounted onto the backplate of the centrifugal wheel. The centrifugal wheel shall be heavy gauge aluminum with backward-inclined, non-overloading blades and be computer balanced.

Motor shall be open construction, NEMA design B. Optional variable speed control on some models allows for field adjustment and system balance. The unit shall be equipped with a safety disconnect device.

(Backdraft damper, epoxy coating, roof curb and other accessories shall be listed in the fan schedule).

CUDA06 - CUDA10 Performance Data

CUDA06 CFM at Static Pressure														RPM RANGE OF SELECTED MODELS			RPM			
0.00		.125		.250		.375		.500		.625		.750		1.00		CUDA06A11		CUDA06C16	CUDA06E16	
BHP	Sone	BHP	Sone	BHP	Sone	BHP	Sone	BHP	Sone	BHP	Sone	BHP	Sone	BHP	Sone	BHP	Sone	1/25 HP	1/13 HP	1/10 HP
183																				550
0.01	0.6																			
266	180																			800
0.01	2.3	0.01	1.3																	
315	251	141																		950
0.01	3.4	0.01	2.6	0.01	2.1															
365	309	235	133																	1100
0.02	4.7	0.02	4.2	0.02	3.6	0.02	3.2													
415	364	315	226	137																1250
0.03	6.5	0.03	6.1	0.03	5.5	0.03	5.1	0.03	4.7											
465	420	377	320	234	155															1400
0.04	7.8	0.04	7.3	0.04	6.7	0.04	6.4	0.04	6.1	0.04	7.6									
531	493	453	415	360	283	218														1600
0.05	10.1	0.05	9.4	0.06	8.8	0.06	8.1	0.06	7.9	0.06	7.6	0.06	7.6							
548	511	471	436	388	315	248														1650
0.06	10.8	0.06	10.1	0.06	9.4	0.07	8.8	0.07	8.6	0.07	8.2	0.07	8.2							

CUDA08 CFM at Static Pressure														RPM RANGE OF SELECTED MODELS			RPM			
0.00		.125		.250		.375		.500		.625		.750		1.00		CUDA08A11		CUDA08C15	CUDA08E16	
BHP	Sone	BHP	Sone	BHP	Sone	BHP	Sone	BHP	Sone	BHP	Sone	BHP	Sone	BHP	Sone	BHP	Sone	1/25 HP	1/13 HP	1/10 HP
233																				550
0.00	0.5																			
339	256																			800
0.01	2.2	0.01	1.3																	
402	332	222																		950
0.01	3.4	0.01	2.5	0.02	2.2															
466	408	342	209																	1100
0.02	4.6	0.02	4.1	0.02	3.9	0.02	3.7													
530	480	424	342	215																1250
0.03	6.3	0.03	5.9	0.03	5.8	0.04	5.6	0.03	5.4											
593	549	498	452	360	244															1400
0.04	7.6	0.04	7.2	0.05	7.0	0.05	6.8	0.05	6.7	0.04	6.5									
657	617	574	529	480	390	289														1550
0.06	8.9	0.06	8.6	0.06	8.1	0.06	8.2	0.07	8.0	0.07	7.9	0.06	7.9							
678	639	599	553	512	431	343														1600
0.06	9.4	0.06	9.1	0.07	8.6	0.07	8.7	0.07	8.5	0.08	8.3	0.07	8.3							

CUDA10 CFM at Static Pressure														RPM RANGE OF SELECTED MODELS			RPM			
0.00		.125		.250		.375		.500		.625		.750		1.00		CUDA10A11		CUDA10C15	CUDA10E15	
BHP	Sone	BHP	Sone	BHP	Sone	BHP	Sone	BHP	Sone	BHP	Sone	BHP	Sone	BHP	Sone	BHP	Sone	1/25 HP	1/13 HP	1/10 HP
299																				550
0.00	0.2																			
435	350																			800
0.01	1.8	0.01	1.1																	
517	450	344																		950
0.02	2.9	0.02	2.5	0.02	1.8															
598	546	472	355																	1100
0.03	4.7	0.03	4.4	0.03	3.6	0.03	3.1													
680	637	575	501	386																1250
0.04	6.8	0.04	6.5	0.05	5.9	0.05	5.2	0.05	4.8											
762	725	673	616	540	434															1400
0.05	8.1	0.05	7.8	0.06	7.4	0.07	6.6	0.07	6.2	0.07	5.7									
816	783	737	684	625	542															1500
0.06	8.9	0.07	8.7	0.07	8.4	0.08	7.7	0.08	7.2	0.08	6.7									
843	811	768	717	663	590	495														1550
0.07	9.4	0.07	9.1	0.08	8.9	0.09	8.3	0.09	7.7	0.09	7.2	0.09	6.8							

Performance shown is for Type A: free inlet, free outlet. Performance ratings do not include the effects of appurtenances in the airstream. The sound ratings shown are loudness values in fan sones at 5 ft. (1.5 m) in a hemispherical free field calculated per AMCA Standard 301. Values shown are for installation Type A: free inlet fan sone levels. AMCA Certified Ratings apply to the CUDA Roof Ventilator constant speed fans and not variable speed fans.

CUDA12 - CUDA13 Performance Data

CUDA12														CFM at Static Pressure						RPM RANGE OF SELECTED MODELS			RPM
0.00		.125		.250		.375		.500		.625		.750		1.00		CUDA12E10	CUDA12J16	CUDA12J17*					
BHP	Sone	BHP	Sone	BHP	Sone	BHP	Sone	BHP	Sone	BHP	Sone	BHP	Sone	BHP	Sone	BHP	Sone	1/8 HP	1/2 HP	1/2 HP			
566		393																	550				
0.01	1.8	0.01	1.3																				
669		531																	650				
0.02	2.7	0.02	2.7																				
772		657		510															750				
0.03	3.8	0.03	3.8	0.04	3.0																		
874		774		658		488													850				
0.04	5.0	0.05	4.9	0.05	4.5	0.05	3.8																
977		888		791		676													950				
0.06	6.1	0.06	5.9	0.07	6.0	0.07	5.2																
1054		972		885		784		654											1025				
0.07	6.9	0.08	6.8	0.09	7.0	0.09	6.4	0.09	5.7														
1183		1109		1035		951		858		740									1150				
0.10	8.4	0.11	8.2	0.12	8.4	0.12	8.3	0.13	7.6	0.13	7.0												
1337		1272		1207		1139		1061		980		884							1300				
0.15	10.2	0.16	10.0	0.17	10.2	0.17	10.5	0.18	10.1	0.19	9.4	0.19	8.9										
1492		1433		1374		1315		1253		1182		1109		926					1450				
0.20	12.4	0.21	12.1	0.22	12.3	0.23	12.6	0.24	12.7	0.25	12.3	0.26	11.7	0.26	10.7								
1646		1593		1540		1487		1432		1374		1310		1176					1600				
0.27	14.7	0.28	14.5	0.30	14.5	0.31	14.8	0.32	15.1	0.33	15.2	0.34	14.9	0.35	13.9								
1739		1688		1638		1588		1537		1484		1427		1302					1690				
0.32	16.3	0.33	16.0	0.35	16.0	0.36	16.3	0.37	16.6	0.38	16.9	0.39	16.8	0.41	15.8								
1775		1725		1676		1627		1577		1526		1471		1349					1725				
0.34	16.9	0.35	16.6	0.37	16.6	0.38	16.8	0.39	17.2	0.40	17.5	0.41	17.5	0.43	16.6								

CUDA13														CFM at Static Pressure						RPM RANGE OF SELECTED MODELS			RPM
0.00		.125		.250		.375		.500		.625		.750		1.00		CUDA13F11	CUDA13J15	CUDA13K17*					
BHP	Sone	BHP	Sone	BHP	Sone	BHP	Sone	BHP	Sone	BHP	Sone	BHP	Sone	BHP	Sone	BHP	Sone	1/5 HP	1/2 HP	3/4 HP			
763		566																	550				
0.02	1.9	0.02	1.0																				
936		784		580															675				
0.03	3.1	0.04	2.4	0.04	1.8																		
1109		977		845		641													800				
0.06	4.5	0.07	3.7	0.07	3.3	0.07	2.9																
1248		1129		1020		873		663											900				
0.08	5.6	0.09	4.9	0.10	4.6	0.10	4.2	0.10	3.8														
1387		1279		1180		1073		924		716									1000				
0.11	6.7	0.12	6.2	0.13	5.8	0.14	5.6	0.14	5.2	0.13	4.9												
1560		1463		1372		1287		1182		1048		888							1125				
0.16	8.3	0.17	8.0	0.19	7.5	0.20	7.4	0.20	7.1	0.20	6.7	0.19	6.4										
1733		1646		1562		1484		1405		1307		1186		821					1250				
0.22	10.2	0.24	9.9	0.25	9.4	0.26	9.1	0.27	9.1	0.27	8.8	0.27	8.4	0.24	7.8								
1872		1791		1712		1638		1567		1490		1393		1160					1350				
0.28	11.9	0.29	11.7	0.31	11.2	0.33	10.8	0.33	10.7	0.34	10.6	0.34	10.3	0.34	9.5								
2045		1971		1898		1829		1763		1698		1626		1436					1475				
0.36	13.6	0.38	13.4	0.40	13.0	0.42	12.5	0.43	12.2	0.44	12.2	0.44	12.1	0.45	11.5								
2184		2114		2046		1980		1916		1855		1794		1641					1575				
0.44	14.9	0.46	14.8	0.48	14.4	0.50	13.9	0.52	13.6	0.53	13.4	0.54	13.4	0.54	13.0								
2427		2363		2302		2241		2182		2126		2071		1958					1750				
0.61	17.5	0.63	17.4	0.65	17.1	0.67	16.6	0.69	16.2	0.71	15.9	0.72	15.8	0.74	15.7								

Performance shown is for Type A: free inlet, free outlet. Performance ratings do not include the effects of appurtenances in the airstream. The sound ratings shown are loudness values in fan sones at 5 ft. (1.5 m) in a hemispherical free field calculated per AMCA Standard 301. Values shown are for installation Type A: free inlet fan sone levels.

* - These models are not compatible with variable speed control.

AMCA Certified Ratings apply to the CUDA Roof Ventilator constant speed fans and not variable speed fan.

CUDA15 - CUDA 20 Performance Data

CUDA15										CFM at Static Pressure			RPM RANGE OF SELECTED MODELS			RPM				
0.00		.125		.250		.375		.500		.625		.750		1.00			CUDA15H10	CUDA15K15	CUDA15L17*	
BHP	Sone	BHP	Sone	BHP	Sone	BHP	Sone	BHP	Sone	BHP	Sone	BHP	Sone	BHP	Sone	BHP	Sone	1/3 HP	3/4 HP	1 HP
1033		832																		550
0.03	2.7	0.04	1.7																	650
1221		1056		842																750
0.05	3.9	0.06	3.0	0.06	2.6															850
1409		1268		1110		885														950
0.08	5.1	0.09	4.3	0.10	3.8	0.10	3.5													1090
1596		1473		1342		1184		969												1150
0.12	6.4	0.13	5.7	0.14	5.2	0.14	5.0	0.14	4.6											1250
1784		1675		1560		1435		1280		1083										1350
0.17	7.9	0.18	7.1	0.19	6.8	0.20	6.4	0.20	6.3	0.20	5.9									1425
2047		1952		1854		1752		1640		1509		1347								1550
0.26	10.3	0.27	9.5	0.28	9.1	0.29	8.7	0.30	8.4	0.30	8.4	0.30	8.1							1725
2160		2070		1978		1882		1780		1666		1529								
0.30	11.4	0.32	10.6	0.33	10.2	0.34	9.9	0.35	9.5	0.35	9.4	0.36	9.3							
2348		2265		2181		2094		2004		1908		1800		1527						
0.39	13.3	0.40	12.6	0.42	12.2	0.43	11.9	0.44	11.5	0.45	11.2	0.46	11.2	0.45	10.8					
2535		2459		2382		2302		2220		2135		2044		1829						
0.49	14.9	0.51	14.2	0.52	13.7	0.54	13.4	0.55	13.1	0.56	12.8	0.57	12.5	0.58	12.5					
2676		2604		2531		2456		2379		2301		2218		2031						
0.57	16.2	0.59	15.5	0.61	14.9	0.63	14.6	0.64	14.3	0.65	14.0	0.66	13.8	0.68	13.6					
2911		2845		2778		2709		2640		2569		2496		2340						
0.74	18.4	0.76	17.6	0.78	17.1	0.80	16.8	0.82	16.5	0.83	16.3	0.84	16.0	0.86	15.5					
3240		3180		3120		3059		2998		2935		2872		2740						
1.02	22	1.04	21	1.06	21	1.09	20	1.11	19.8	1.12	19.6	1.14	19.4	1.17	18.8					

CUDA16										CFM at Static Pressure			RPM OF SELECTED MODELS			RPM				
0.00		.125		.250		.375		.500		.625		.750		1.00			CUDA16J8*	CUDA16L11*	CUDA16N17*	
BHP	Sone	BHP	Sone	BHP	Sone	BHP	Sone	BHP	Sone	BHP	Sone	BHP	Sone	BHP	Sone	BHP	Sone	1/2 HP	1 HP	2 HP
2187		2037		1884		1708		1523		1082										825
0.20	8.4	0.21	7.4	0.23	6.7	0.23	6.6	0.23	6.2	0.21	5.8									1160
3075		2967		2862		2755		2644		2517		2394		2125						
0.55	15.9	0.57	15.0	0.60	14.1	0.62	13.3	0.63	12.9	0.64	12.9	0.65	12.9	0.65	12.0					
4640		4568		4496		4426		4356		4286		4216		4072						
1.90	30	1.93	29	1.96	29	1.99	28	2.03	27	2.06	27	2.09	26	2.14	25					

CUDA18										CFM at Static Pressure			RPM OF SELECTED MODELS		RPM					
0.00		.125		.250		.375		.500		.625		.750		1.00		CUDA18J8*	CUDA18L11*			
BHP	Sone	BHP	Sone	BHP	Sone	BHP	Sone	BHP	Sone	BHP	Sone	BHP	Sone	BHP	Sone	1/2 HP	1 HP			
2919		2679		2550		2389		2194		1888		1422								825
0.30	9.8	0.33	8.6	0.34	8.4	0.36	8.0	0.36	7.6	0.34	7.0	0.31	6.6							1160
4104		3875		3765		3673		3580		3473		3350		3069						
0.85	18.6	0.88	17.1	0.91	16.4	0.93	16.1	0.96	16.0	0.98	15.5	0.99	15.0	0.99	14.3					

CUDA20										CFM at Static Pressure			RPM OF SELECTED MODEL	RPM						
0.00		.125		.250		.375		.500		.625		.750			1.00		CUDA20M11*			
BHP	Sone	BHP	Sone	BHP	Sone	BHP	Sone	BHP	Sone	BHP	Sone	BHP	Sone	BHP	Sone	1-1/2 HP				
4942		4822		4702		4583		4461		4326		4169		3830						1160
1.28	22	1.33	19.9	1.36	19.0	1.39	19.2	1.41	19.6	1.43	19.4	1.44	18.9	1.46	18.8					

Performance shown is for Type A: free inlet, free outlet. Performance ratings do not include the effects of appurtenances in the airstream. The sound ratings shown are loudness values in fan sones at 5 ft. (1.5m) in a hemispherical free field calculated per AMCA Standard 301. Values shown are for installation Type A: free inlet fan sone levels

* - These models are not compatible with variable speed control
 AMCA Certified Ratings apply to the CUDA Roof Ventilator constant speed fans and not variable speed fan:

Installation

All models are shipped fully assembled and ready for installation. Always inspect equipment for transit damage before accepting delivery to assure a valid claim. Special handling and storage procedures are required if unit is to remain idle for a long time prior to installation.

Placement

All belt-driven units must be accessibly installed for maintenance and servicing of belts, motors and pulleys.

Mounting

Satisfactory operation of upblast power roof ventilators requires mounting on adequately designed and constructed roof curbs. Prefabricated curbs for convenience in installation are available from ILG. Install with base of unit horizontal. Provide adequate caulking, flashing or other weather-proofing means.

Inspection

Check centrifugal wheel for free rotation.

Check belt for proper tension. (CUBA)

Check motor and fan sheave faces for proper alignment. (CUBA)

Check circuit phase, voltage and wiring connection against that shown on motor nameplate.

Check direction of fan rotation for proper air flow.

Check belt after one week of operation for proper tension. (CUBA)

Maintenance

Units should be checked monthly for the first two or three months and periodically thereafter.

Cleaning

Units should be cleaned of grease and material buildup every three months or when necessary, depending on the condition of air being exhausted and frequency of use. Grease trough, drain and container should be checked and emptied as required to prevent grease overflow, as often as every one or two weeks with heavy grease applications such as char-broilers. Units should also be checked for eroded parts which should be replaced to avoid structural damage and possible failure.

Lubrication

Fan bearings on CUBA models are permanently sealed and require **no** lubrication. Motor bearings should be lubricated according to the motor manufacturer's instructions.

Adjustment of Variable Pitch Pulley and Belt (CUBA)

Variable pitch pulley may be adjusted within catalog RPM range to alter performance. However, adjustment beyond catalog RPM range may cause motor overload and possible premature motor failure. Pulley alignment and belt tension should be adjusted if necessary. Both motor and driven pulleys should be at right angles to the shafts, and the V-grooves should be aligned with each other. Inspection of drive components every 6 to 12 months is recommended.

WARNING



CAUTION

DO NOT INSTALL FAN WITH MOVING PARTS WITHIN 8 FEET OF FLOOR OR GRADE LEVEL WITHOUT A GUARD THAT COMPLIES WITH OSHA REGULATIONS. **DO NOT** USE UNLESS ELECTRICAL WIRING COMPLIES WITH ALL APPLICABLE CODES. **DO NOT** WIRE WITHOUT PROVIDING FOR A POWER SOURCE DISCONNECT AT THE FAN ITSELF. **DO NOT** SERVICE EXCEPT BY A QUALIFIED MAINTENANCE TECHNICIAN AND ONLY AFTER DISCONNECTING THE POWER SOURCE. FAILURE TO OBSERVE THESE PRECAUTIONS CAN RESULT IN SERIOUS INJURY OR DEATH.

To convert air performance (CFM and SP) and power (BHP) to metric units, multiply CFM x .000472 to obtain cubic meters per second (m³/s). Multiply SP x 248.36 to obtain Pascals (Pa). Multiply BHP x .7457 to obtain Kilowatts (kW).

Example: 3904 CFM x .000472 = 1.8427 m³/s
0.125 SP x 248.36 = 31.05 Pa
0.886 BHP x .7457 = 0.661 kW

CUBA/CUDA Options and Accessories

Grease Extraction Application Accessories

Prefabricated Roof Curbs

Roof curbs for grease extraction CUBA models meet NFPA 96 system requirements for minimum PRV discharge height above the roof line. Curb height for sizes 18 and below is 20", and for sizes 20 and above is 18". Curbs with venting on two or four sides are also available. All curbs are insulated, feature a weather-resistant, continuous welded construction and provide convenience in installation of PRV units for both insulated and non-insulated roof decks.

Safety Disconnects

Safety disconnects cut power to motor for servicing of unit. A factory mounted and wired disconnect is an option for CUBA units with the UL 762 designation. The disconnect may either be interior with an external weather-proof junction box (all units), or external (units up to 2 hp only). Wiring is completed from the motor to the exterior box.

Grease Collector

Grease pans collect grease drained from the fan. An integral baffle contains the grease while allowing water to flow from the pan. The grease collector should be attached to the curb below the standard drain.

General Ventilation Accessories

Prefabricated Roof Curbs

Insulated roof curbs with weather-resistant, continuous welded construction are available for convenience in installation for both insulated and non-insulated roof decks.

Safety Disconnects

Safety disconnects cut power to motor for servicing of unit. A disconnect switch is an accessory available on CUBA units used for general ventilation. The switch is shipped loose for field installation and power source connection. An optional wiring harness is available to connect the motor to the switch at the internal junction box. A factory disconnect device with mounted and wired internal junction box is standard for all CUDA models.

Backdraft Dampers

Gravity or motor operated backdraft dampers are available. They are aluminum construction and designed for installation in prefabricated roof curbs.

Birdguards

Birdguards are available to prevent entry of birds or other potentially damaging objects.

General Options and Accessories

Hinged Base Kits

Hinged bases are specifically designed to provide easy access for cleaning and servicing the lower parts of CUBA units.

Roof Handle

Aluminum handle facilitates removal of the roof. Roof handles are standard for CUBA models with a UL762 designation.

Special Motors

Two-speed, totally enclosed, energy efficient and explosion-proof motors for hazardous locations may be available for many models. Motor requirements may affect UL Listings.

Protective Coatings

Fan units are not recommended for exhausting air of a corrosive nature. However, special protective coatings are available where units may be exposed to corrosive exterior conditions. Parts requiring painting are processed through the American Coolair five-stage pretreatment system prior to the application of any coatings to insure maximum finish adhesion. These parts use a thermosetting epoxy powder paint with an average thickness of 3 mils and baked at 400° F to a smooth, hard continuous finish. Consult your ILG Industries representative for available coatings.

Speed Controller (For selected CUDA models only)

Solid state speed controller provides capability to change performance and speed ranging from 50% to 100% of fan capacity. This permits adjustment for fine tuning and balancing the ventilation system (see performance tables for compatible models).

CUBA Specification Checklist

- Units provide grease-laden vapor extraction and general exhaust with vertical discharge for low to medium air volumes, especially in commercial and institutional kitchens.
- Centrifugal design has advantages of compact, attractive appearance, quiet operation and performance against higher static pressures.
- Variable pitch belt drive allows for speed adjustment.
- Adjustable hinged motor bracket with single bolt adjustment facilitates maintenance of belt tension.
- Weatherproof heavy duty spun aluminum housing and motor compartment cover resist corrosion, maintaining appearance.
- Deep-spun, overlapping, one-piece venturi/bottom outer housing minimizes noise, reduces air turbulence and improves efficiency.
- Unique "C-Drive" design reduces radial bearing loads, providing a calculated L10 bearing life of over 1,000,000 hours.
- Aluminum centrifugal wheel is quiet, non-overloading backward-inclined design and is computer balanced.
- Standard open drip-proof motor is out of the airstream for protection.
- The motor is mounted with the electrical terminal board up for convenient connection and servicing.
- The motor compartment is cooled by a forced air ventilation system, extending motor life.
- Units have the UL Label for the removal of grease-laden vapors and fumes (UL 762), or for general ventilation (UL 705).
- AMCA Seal assures certified rating of air and sound performance.
- Heavy duty neoprene isolators eliminate metal-to-metal contact, reducing vibration and sound.

Limited Warranty

In the sale of its products, American Coolair Corporation agrees to correct, by repairs or replacement, any defects in workmanship or material that may develop under proper and normal use during the period of one year from the date of shipment from the factory. Any product or part proving, upon American Coolair's examination, to be defective during limited warranty period will be repaired or replaced, at American Coolair's option, f.o.b. factory, without charge.

Deterioration or wear caused by chemicals, abrasive action or excessive heat shall not constitute defects.

Motors are guaranteed only to the extent of the manufacturer's warranty.

American Coolair's limited warranty does not apply to any of its products or parts that have been subject to accidental damage, misuse by the user, unauthorized alterations, improper installation or electrical wiring, or lack of proper lubrication or other service requirements as established by American Coolair.

Repairs or replacements provided under the above terms shall constitute fulfillment of all American Coolair's obligations with respect to limited warranty.

THE LIMITED WARRANTY STATED HEREIN IS IN LIEU OF ALL OTHER WARRANTIES, EXPRESS, STATUTORY OR IMPLIED, INCLUDING WITHOUT LIMITATION THAT OF MERCHANTABILITY AND FITNESS.

NO LIABILITY FOR REINSTALLATION COST OR FOR ANY SPECIAL, INDIRECT OR CONSEQUENTIAL DAMAGES OF ANY NATURE IS ASSUMED OR SHALL BE IMPOSED UPON AMERICAN COOLAIR.



AMERICAN COOLAIR CORPORATION

CUDA Specification Checklist

- Units provide grease-laden vapor extraction and general exhaust with vertical discharge for low to medium air volumes in commercial, institutional and light manufacturing buildings.
- Centrifugal design has advantages of compact, attractive appearance, quiet operation and performance against higher static pressures.
- Direct-drive has advantages of minimal maintenance and operating costs.
- Safety disconnect device allows power to be cut off for servicing of unit.
- Weatherproof heavy duty spun aluminum housing and motor compartment cover resist corrosion, maintaining appearance.
- Deep-spun, overlapping, one-piece venturi/bottom outer housing minimizes noise, reduces air turbulence and improves efficiency.
- Aluminum centrifugal wheel is quiet, non-overloading, backward-inclined design and is computer balanced.
- Standard open motor is out of the airstream for protection.
- The motor compartment is cooled by a forced air ventilation system, extending motor life.
- Units have the UL Label for general ventilation (UL 705).
- AMCA Seal assures certified rating of air and sound performance.
- Heavy duty neoprene isolators eliminate metal-to-metal contact, reducing vibration and sound.
- Units are factory run and tested prior to shipment for dependable operation.

REPRESENTED BY:

GENERAL OFFICE, JACKSONVILLE, FLORIDA 32203-2300 ~ (904) 389-3646
FAX: (904) 387-3449, (904) 381-7560 ~ WEBSITE: www.coolair.com ~ E-MAIL: fans@coolair.com
VANE AXIAL FANS ~ TUBE AXIAL FANS ~ PROPELLER FANS ~ POWER ROOF VENTILATORS ~ CENTRIFUGAL VENTILATORS
MEMBER OF AMCA

Form No. 715-15-3 (February, 2001)