



# Air Monitor

Precision Airflow Measurement  
An ONICON Brand

## VOLU-probe/VS

### PITOT AIRFLOW MEASUREMENT STATION

The VOLU-probe/VS utilizes one or more VOLU-probes factory mounted in a casing to sense and average total and static pressure traverses of an airstream. The station is designed for applications with limited straight duct runs and/or moderately disturbed airflow.



AMCA  
WORLDWIDE  
CERTIFIED  
RATINGS  
AIRFLOW  
MEASUREMENT  
STATION  
AIR  
PERFORMANCE  
AIR  
MOVEMENT  
AND CONTROL  
ASSOCIATION  
INTERNATIONAL, INC.®  
www.amca.org



FACTORY CONFIGURED



ON TIME DELIVERY



BEST CUSTOMER SERVICE

• Ducted Airflow • Fan Discharge •

# VOLU-probe/VS PITOT AIRFLOW MEASUREMENT TRAVERSE STATION



## ACCURACY

*Air Monitor Corporation certifies that the VOLU-probe/VS Airflow Traverse Station shown herein is licensed to bear the AMCA Certified Ratings Seal - Airflow Measurement Station Performance. The ratings shown are based on tests and procedures performed in accordance with AMCA Publication 611 and comply with the requirements of the AMCA Certified Ratings Program.*



## DESCRIPTION

The VOLU-probe/VS Station utilizes one or more VOLU-probe Airflow Traverse Probes, factory mounted in a rigid, welded, galvanized casing, to sense and average separate total and static pressure traverses of an airstream. Multiple sets of total and static pressure sensing points, positioned along the length of each VOLU-probe on an equal area basis, traverse the airstream and average the sensed pressures in separate internal manifolds. Factory installed static and total pressure signal tubing connect the individual VOLU-probes together, terminating at the galvanized casing for field connection. The VOLU-probe/VS is suited for installations in ductwork, fan inlets, etc., operating at temperatures ranging from -20 to 200°F. As a primary flow sensing means, the VOLU-probe/VS can be used in applications ranging from commercial building HVAC to laboratory, pharmaceutical, electronics production, and health care institutions.

## FEATURES

**Ready to Mount Station** - includes factory-mounted probes for quick install and guarantees the configuration and performance.

**Accuracy** - AMCA certified for ±2% of reading accuracy throughout velocity ranges up to 4,000 FPM.

**Flow Angle Accommodation** - Insensitive to flow angle variations of as much as ±30° when faced in the normal direction of flow.

**Minimal Resistance to Airflow** - Less than 0.1 inch of water column pressure drop for velocities up to 4,000 FPM.

**Environment Versatility** - Can operate in any humidity range from 0 to 100% RH without affecting the reading and measures up to 10,000 FPM in heated environments up to 200°F.

**Low Velocity Measurement** - The amplified signal offering measures down to 120 FPM with ±3% accuracy.

**Low Cost - High Accuracy** - Achieve ±3% of the reading for a fraction of the cost of thermal dispersion technology.

**BMS/BAS Communication** - Pairing VOLU-probes with the VELTRON III provides Display, BACnet, MODBUS, and Analog outputs for ±3% of the reading accuracy.

### Test Data

Model: VOLU-probe/VS

Type: Differential Pressure

Conversion Formula:  $Velocity = 1096 \sqrt{\frac{AMS \text{ Velocity Pressure}}{Air \text{ Density}}}$

Sizes & Shapes Tested: 36" x 36" Rectangular;  
36" dia. Circular

Applicable Sizes Rated: Rectangular stations with cross-sectional areas between 4.5 and 18.0 square feet;  
Circular stations with cross-sectional areas between 3.5 and 14.1 square feet.

Test Setup: AMCA Stand 610, Figure 1

### Test Results - Rectangular Stations

Reference Volume, ACFM	Reference Velocity, AFPM	% Accuracy	Airflow Resistance in. WC
35,134	4,015	0.53	.082
31,391	3,488	0.45	.064
26,018	2,891	0.39	.044
19,456	2,162	0.23	.028
13,971	1,552	0.10	.013
8,832	981	-1.40	.005

### Test Results - Circular Stations

Reference Volume, ACFM	Reference Velocity, AFPM	% Accuracy	Airflow Resistance in. WC
29,602	4,188	1.03	.066
24,915	3,525	0.97	.047
18,728	2,649	0.30	.033
14,463	2,046	0.15	.017
10,455	1,479	0.16	.010
8,285	1,172	-1.37	.005

**HOW IT WORKS**

The VOLU-probe/VS operates on the Fechheimer Pitot derivative of the multi-point, self-averaging Pitot principle to measure the total and static pressure components of airflow. Total pressure sensing ports, with chamfered entrances to eliminate air direction effect, are located on the leading surface of the individual VOLU-probes to sense the impact pressure ( $P_t$ ) of the approaching airstream (Figure 1). Fechheimer pairs of static pressure sensing ports, positioned at designated angles offset from the flow normal vector, minimize the error inducing effect of directionalized airflow. As the flow direction veers from the normal, one static sensor is exposed to a higher pressure ( $P_s + \text{part of } P_t$ ), whereas the other static sensor experiences a lower pressure ( $P_s - \text{Part of } P_t$ ) of the same magnitude, thereby canceling out the undesired effect of partial total pressure ( $P_t$ ). It is this unique design of offset static pressure and chamfered total pressure sensors (see Figure 2) that makes the VOLU-probe/VS insensitive to approaching, multi-directional, rotating airflow with yaw and pitch up to 30° from straight flow, thereby assuring the accurate measurement of the sensed airflow rate without the presence of an airflow straightener upstream.

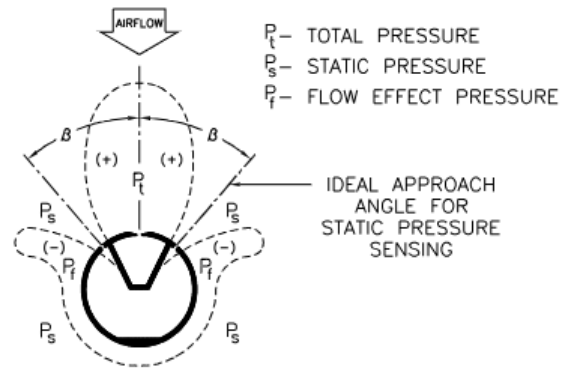

Figure 1

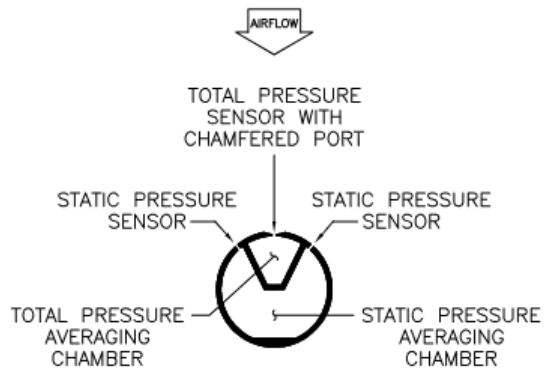
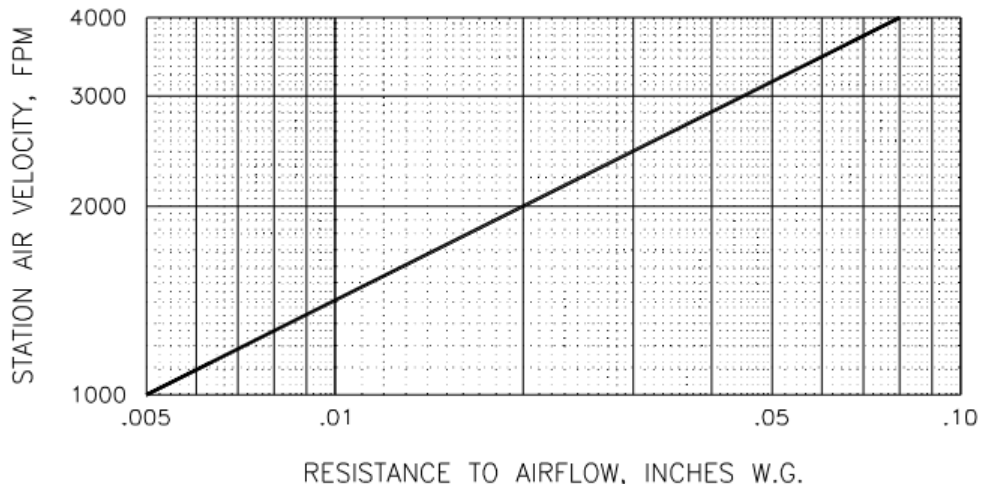

Figure 2

**AIRFLOW RESISTANCE**

Negligible Resistance to Airflow. The VOLU-probe/VS cylindrical configuration and smooth surface free of external sensor protrusions permit the airstream to flow unrestricted around and between the installed traverse probes, creating a very minimal resistance to airflow.



**CONSTRUCTION FEATURES**

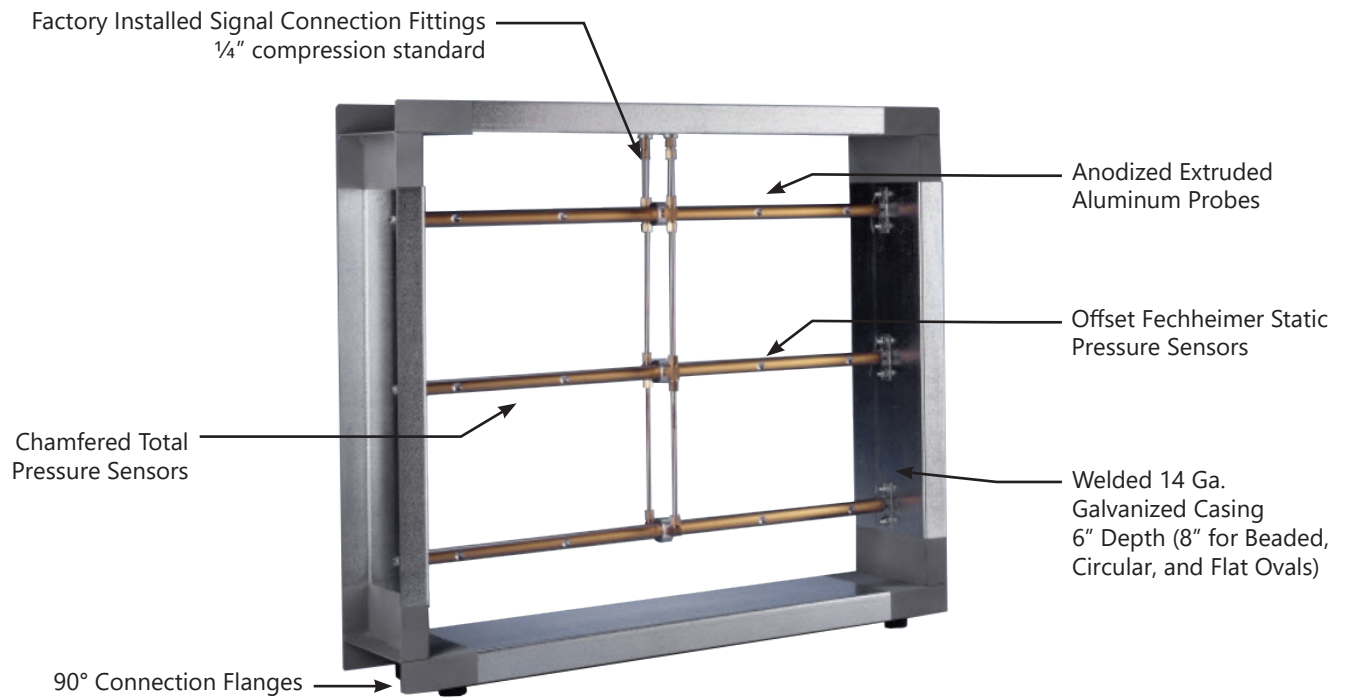

**TRAVERSE PROBE QUANTITIES**

When installed per Air Monitor's Minimum Installation Requirements (see page 5), the quantity and placement of individual probes in a VOLU-probe/VS Airflow Traverse Station (see below) will produce assured measuring accuracy of  $\pm 2\%$  of actual airflow.

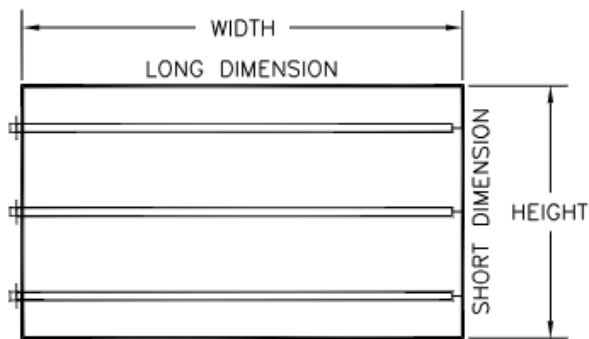

FOR SQUARE AND RECTANGULAR DUCTS

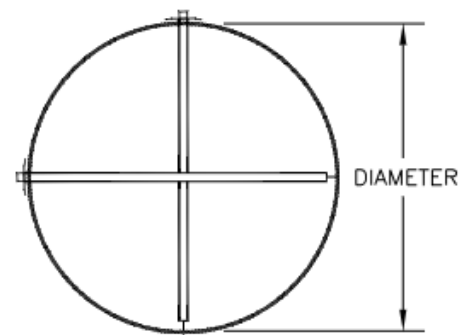

FOR CIRCULAR DUCTS

Height Dimension	Min. Qty of VOLU-probes Recommended	Height Dimension	Min. Qty of VOLU-probes Recommended
8" to 12"	1	>54" to 84"	4
>12" to 30"	2	>84" to 120"	5
>30" to 54"	3	>120" to 180"	6

Height Dimension	Min. Qty of VOLU-probes Recommended
8" to 18"	1
>18" to 72"	2
>72"	3

**MINIMUM INSTALLATION REQUIREMENTS**

Note: VOLU-probe/VS locations shown are not ideal. The locations indicate the minimum clearance required from air turbulence producing sources. Wherever possible, the VOLU-probe/VS should be installed where greater runs of straight duct (or clearances) than shown below exist.

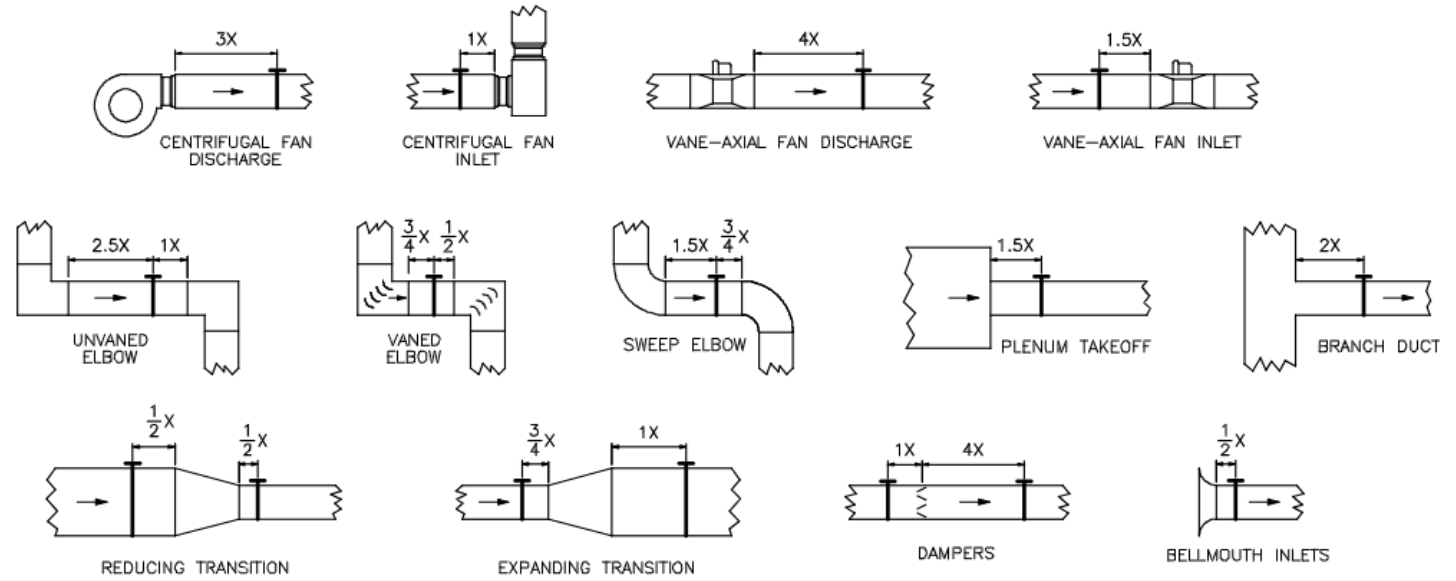

Rectangular Duct:  $x = \frac{2(H \times W)}{H + W}$

Circular Duct:  $x = \text{Duct Diameter}$

**SPECIFICATIONS**

<b>VOLU-probe/VS</b>	
CONFIGURATIONS	Rectangular, circular, and flat oval
ACCURACY	±2% of actual airflow
OPERATING VELOCITY	400-10,000 FPM. 120 to 600 FPM for VOLU-Probe/AS (Amplified Signal)
OPERATING TEMPERATURE	Continuous operation to 200°F
DIRECTIONAL SENSITIVITY	Not measurably affected by directional airflows with pitch and yaw angles up to 30°
RESISTANCE	Shall not exceed 0.025" w.c. @ 2000 FPM or 0.085" w.c. @ 4000 FPM
OUTPUTS	Individually averaged signals of total and static pressure
NUMBER OF PROBES	1-6
NUMBER OF SENSING PORTS	Rectangular: 8" to 144" 2 to 16 ports per probe Circular: 8" to 144", 4 to 12 ports per probe
SENSING PATTERN	Total and static pressure sensors shall be located at the centers of equal areas (for rectangular ducts) or at equal concentric area centers (for circular ducts) across the station's face area.
CASING MATERIAL OF CONSTRUCTION	14 ga. [18 ga. for circular units] galvanized steel (SS option available)
CASING DEPTH	6" deep welding casing with 90° connecting flanges. (8" and 10" options available)
CASING FLANGE	<ul style="list-style-type: none"> <li>Rectangular. 1-1/2" wide, 90° formed. Sizes up to 144" x 144".</li> <li>Circular and Flat Oval.</li> <li>Sizes 10" to 24". 1" wide flanges, or beaded edge.</li> <li>Sizes &gt; 24" and &lt; 45". 1-1/2" wide flange.</li> <li>Sizes &gt; 45". 3/16" x 2" bar stock flanges.</li> </ul>

## MODEL SELECTION GUIDE

### Model Number Coding = VOLU-probe/VSBB-CDEF-GHIJ

#### **VOLU-probe/VS = AIRFLOW TRAVERSE STATION**

##### **VS = Probe Mounting**

VS = Differential pressure AFS

##### **BB = Probe Style**

NS = Normalized signal

AS = Amplified signal

##### **C = Station Configuration**

R = Rectangular

C = Circular

O = Oval

##### **D = Long Dimension (Diameter)**

A = >8 to 12

H = >60 to 72

B = >12 to 18

I = >72 to 84

C = >18 to 24

J = >84 to 96

D = >24 to 30

K = >96 to 108

E = >30 to 36

L = >108 to 120

F = >36 to 44

M = >120 to 132

G = >44 to 60

N = >132 to 144

##### **E = Short Dimension**

A = >8 to 12

I = >72 to 84

B = >12 to 18

J = >84 to 96

C = >18 to 24

K = >96 to 108

D = >24 to 30

L = >108 to 120

E = >30 to 36

M = >120 to 132

F = >36 to 44

N = >132 to 144

G = >44 to 60

9 = Round

H = >60 to 72

##### **F = Width (Depth) Dimension**

1 = 6" depth (default)

2 = 8" depth (beaded edge)

3 = 10" depth (SS Circ > 72")

##### **G = Materials of Construction**

1 = 14 ga galv steel (Rectangular)

2 = 18 ga galv steel (Circ or Oval)

3 = 14 ga series 316 SS (Rectangular)

4 = 18 ga series 316 SS (Circ or Oval)

##### **H = Flange Construction**

1 = 1½" 90° formed flange (Rectangular)

2 = 1" flg, 14 ga welded flange (Circ or Oval up to 24")

3 = 1½" flg, 14 ga welded flange (Circ or Oval >24"-45")

4 = ¾" x 2" bar, weld flange (Circ or Oval ≥45")

5 = Beaded edge (Circ or Oval up to 24" & 8" depth)

##### **I = Probe Orientation and Signal Mounting**

L = Long side (default for rect or oval)

S = Short side (Rect or Oval)

9 = Round (Circ)

##### **J = Process Connections**

1 = ¼" brass compression ftg (default for galv)

2 = ¼" brass hose barb ftg (galv only)

3 = ¼" SS compression ftg (default for SS)

