

Application

The VCD-20 is a control damper used in buildings to regulate the flow air in an HVAC system. They can be used in intake, exhaust, or mixed air application.

Damper Ratings

Velocity

Up to 3000 fpm (15.2 m/s)

Pressure

Up to 5 in. wg (1.2 kPa) - pressure differential

Temperature

-40°F to 250°F (-40°C to 121°C). Consult factory for higher temperatures.



*W & H dimension furnished approximately 1/4 in. (6 mm) undersize.

Construction

| | Standard | Optional |
|---------------------------------|--|---|
| Frame Material | Galvanized Steel | 304SS |
| Frame Material Thickness | 16 ga. (1.5 mm) | 12 ga. (2.7 mm)* |
| Frame Type | 5 in. x 1 in. (123 mm x 25 mm) hat channel | Single flange, Reversed flange, Double flange |
| Blade Material | Galvanized steel | 304SS |
| Blade Thickness | 16 ga. (1.5 mm) | - |
| Blade Type | 3V | - |
| Blade Action | Opposed | Parallel |
| Linkage | Plated steel out of airstream, concealed in jamb | 316SS |
| Axle Bearings | Synthetic | 316SS |
| Axle Material | 1/2 in. dia. Plated steel | 316SS |

*When 12 ga (2.7 mm) frame is selected and the damper height is less than 17 inches (432 mm), low profile top and bottom frame members are utilized. These low profile frame members will be made from 16 ga. (1.5 mm) material.

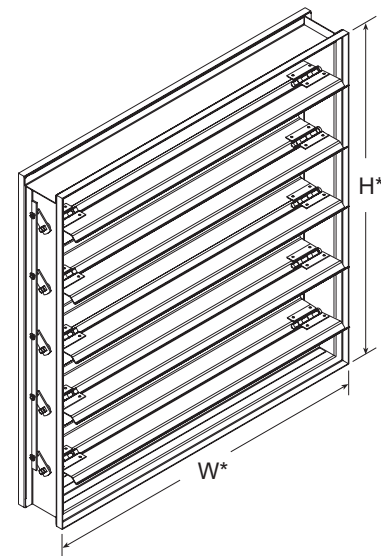

Size Limitations

| W x H | Minimum Size | Maximum Size | |
|---------------|--------------|----------------|------------------|
| | | Single Section | Multiple Section |
| Inches | 6 x 6 | 48 x 74 | Unlimited |
| mm | 152 x 152 | 1219 x 1880 | Unlimited |

Notes:

- Low profile head and sill are used on sizes less than 17 in. (432 mm) high
- Linkage concealed in the frame
- Electric actuator and manual quadrant available. Factory supplied actuators are sized for 1500 fpm (7 m/s) and fully closed differential pressure of 2 in. wg (.5 kPa). contact factory for actuator sizing on applications exceeding those limits.
- In applications where airflow could be uneven, such as a discharge fan, it is imperative to verify that at no point the maximum velocity exceeds the damper's cataloged velocity.
- Blades must be horizontal for either horizontal or vertical mount. If you need vertical blades, see VCD-23V model.

Blade Operation

Parallel blade operation - this configuration requires the damper blades to rotate in the same direction, parallel to one another.

Opposed blade operation - adjacent damper blades rotate opposite one another.

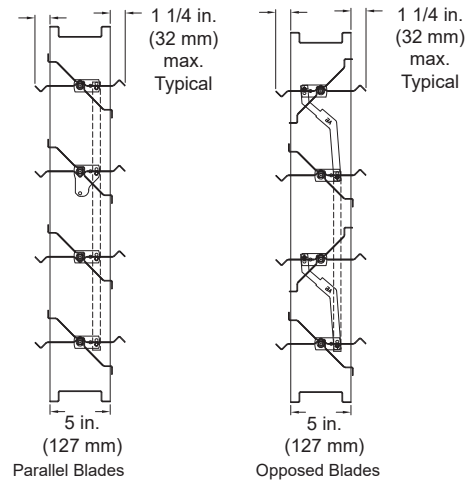

Options

- Actuators (24V, 120V, manual, pull chain)
- Actuator mounting (external, external kit (field assembly), internal)
- Flanges
- Multi-section fastening
- NEMA enclosures (3, 4, 4X, 7)
- [OCI \(open or closed indicator\)](#)
- R Transition
- [Retaining angles](#)
- Sleeves
- Transformers

Frame Options

Channel Frame

The channel frame option is designed for in-duct or slip-in installation. Dampers with external actuators can be rotated in the field 180 degrees to change from right hand to left hand drive (not recommended on parallel blade dampers).

Scan the QR code or click on the link “More Info” for more information on single flange, reverse flange and double flange.



[MORE INFO](#)

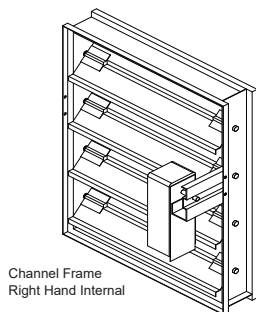

Channel Frame
Right Hand Internal

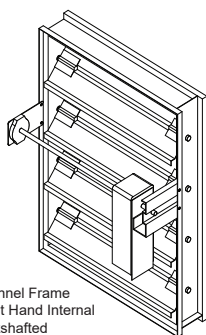

Channel Frame
Right Hand Internal
Jackshafted

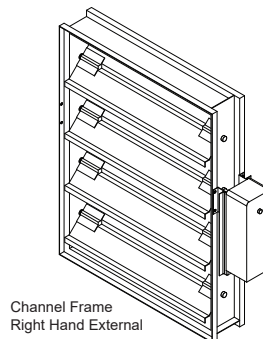

Channel Frame
Right Hand External

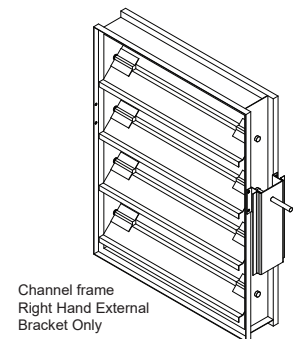

Channel frame
Right Hand External
Bracket Only

AMCA Certified Pressure Drop Data



Greenheck Fan Corporation certifies that the model VCD-20 shown herein is licensed to bear the AMCA Seal. The ratings shown are based on tests and procedures performed in accordance with AMCA Publication 511 and comply with the requirements of the AMCA Certified Ratings Programs. The AMCA Certified Ratings Seal applies to Air Performance ratings.

AMCA 5.2

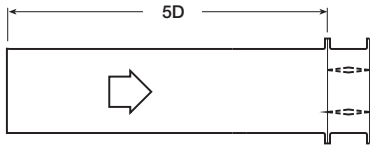

12 in. x 12 in. (305 mm x 305 mm)

| Velocity (fpm) | Pressure Drop (in. wg) |
|----------------|------------------------|
| 500 | 0.04 |
| 1000 | 0.14 |
| 1500 | 0.31 |
| 2000 | 0.55 |
| 2500 | 0.86 |
| 3000 | 1.24 |
| 3500 | 1.69 |
| 4000 | 2.20 |

24 in. x 24 in. (610 mm x 610 mm)

| Velocity (fpm) | Pressure Drop (in. wg) |
|----------------|------------------------|
| 500 | 0.02 |
| 1000 | 0.07 |
| 1500 | 0.16 |
| 2000 | 0.29 |
| 2500 | 0.45 |
| 3000 | 0.65 |
| 3500 | 0.89 |
| 4000 | 1.16 |

36 in. x 36 in. (914 mm x 914 mm)

| Velocity (fpm) | Pressure Drop (in. wg) |
|----------------|------------------------|
| 500 | 0.01 |
| 1000 | 0.04 |
| 1500 | 0.09 |
| 2000 | 0.16 |
| 2500 | 0.25 |
| 3000 | 0.36 |
| 3500 | 0.49 |
| 4000 | 0.64 |

12 in. x 48 in. (305 mm x 1219 mm)

| Velocity (fpm) | Pressure Drop (in. wg) |
|----------------|------------------------|
| 500 | 0.01 |
| 1000 | 0.06 |
| 1500 | 0.13 |
| 2000 | 0.23 |
| 2500 | 0.36 |
| 3000 | 0.52 |
| 3500 | 0.70 |
| 4000 | 0.92 |

48 in. x 12 in. (1219 mm x 305 mm)

| Velocity (fpm) | Pressure Drop (in. wg) |
|----------------|------------------------|
| 500 | 0.03 |
| 1000 | 0.10 |
| 1500 | 0.23 |
| 2000 | 0.41 |
| 2500 | 0.63 |
| 3000 | 0.91 |
| 3500 | 1.24 |
| 4000 | 1.62 |

AMCA 5.3

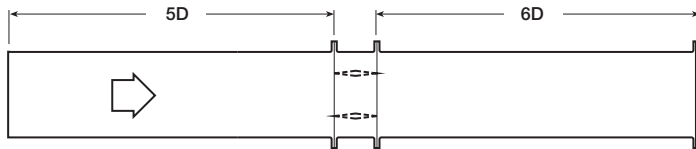

12 in. x 12 in. (305 mm x 305 mm)

| Velocity (fpm) | Pressure Drop (in. wg) |
|----------------|------------------------|
| 500 | 0.02 |
| 1000 | 0.09 |
| 1500 | 0.20 |
| 2000 | 0.36 |
| 2500 | 0.56 |
| 3000 | 0.81 |
| 3500 | 1.10 |
| 4000 | 1.44 |

24 in. x 24 in. (610 mm x 610 mm)

| Velocity (fpm) | Pressure Drop (in. wg) |
|----------------|------------------------|
| 500 | 0.01 |
| 1000 | 0.04 |
| 1500 | 0.09 |
| 2000 | 0.16 |
| 2500 | 0.25 |
| 3000 | 0.35 |
| 3500 | 0.48 |
| 4000 | 0.63 |

36 in. x 36 in. (914 mm x 914 mm)

| Velocity (fpm) | Pressure Drop (in. wg) |
|----------------|------------------------|
| 500 | 0.01 |
| 1000 | 0.03 |
| 1500 | 0.06 |
| 2000 | 0.11 |
| 2500 | 0.17 |
| 3000 | 0.24 |
| 3500 | 0.33 |
| 4000 | 0.42 |

12 in. x 48 in. (305 mm x 1219 mm)

| Velocity (fpm) | Pressure Drop (in. wg) |
|----------------|------------------------|
| 500 | 0.01 |
| 1000 | 0.04 |
| 1500 | 0.10 |
| 2000 | 0.17 |
| 2500 | 0.27 |
| 3000 | 0.39 |
| 3500 | 0.53 |
| 4000 | 0.70 |

48 in. x 12 in. (1219 mm x 305 mm)

| Velocity (fpm) | Pressure Drop (in. wg) |
|----------------|------------------------|
| 500 | 0.02 |
| 1000 | 0.07 |
| 1500 | 0.16 |
| 2000 | 0.29 |
| 2500 | 0.45 |
| 3000 | 0.64 |
| 3500 | 0.88 |
| 4000 | 1.14 |

AMCA 5.5

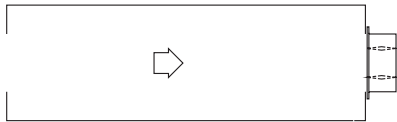

12 in. x 12 in. (305 mm x 305 mm)

| Velocity (fpm) | Pressure Drop (in. wg) |
|----------------|------------------------|
| 500 | 0.06 |
| 1000 | 0.22 |
| 1500 | 0.50 |
| 2000 | 0.89 |
| 2500 | 1.39 |
| 3000 | 2.00 |
| 3500 | 2.72 |
| 4000 | 3.55 |

24 in. x 24 in. (610 mm x 610 mm)

| Velocity (fpm) | Pressure Drop (in. wg) |
|----------------|------------------------|
| 500 | 0.03 |
| 1000 | 0.14 |
| 1500 | 0.31 |
| 2000 | 0.54 |
| 2500 | 0.85 |
| 3000 | 1.22 |
| 3500 | 1.66 |
| 4000 | 2.17 |

36 in. x 36 in. (914 mm x 914 mm)

| Velocity (fpm) | Pressure Drop (in. wg) |
|----------------|------------------------|
| 500 | 0.03 |
| 1000 | 0.12 |
| 1500 | 0.26 |
| 2000 | 0.46 |
| 2500 | 0.73 |
| 3000 | 1.05 |
| 3500 | 1.42 |
| 4000 | 1.86 |

12 in. x 48 in. (305 mm x 1219 mm)

| Velocity (fpm) | Pressure Drop (in. wg) |
|----------------|------------------------|
| 500 | 0.03 |
| 1000 | 0.13 |
| 1500 | 0.30 |
| 2000 | 0.53 |
| 2500 | 0.83 |
| 3000 | 1.19 |
| 3500 | 1.62 |
| 4000 | 2.11 |

48 in. x 12 in. (1219 mm x 305 mm)

| Velocity (fpm) | Pressure Drop (in. wg) |
|----------------|------------------------|
| 500 | 0.04 |
| 1000 | 0.17 |
| 1500 | 0.38 |
| 2000 | 0.67 |
| 2500 | 1.04 |
| 3000 | 1.50 |
| 3500 | 2.05 |
| 4000 | 2.67 |

Leakage Data

Leakage testing was conducted in accordance with AMCA Standard 500-D and is expressed as cfm/ft² of damper face area. All data has been corrected to represent standard air at a density of 0.075 lb/ft³ (1.204 kg/m³).

VCD-20

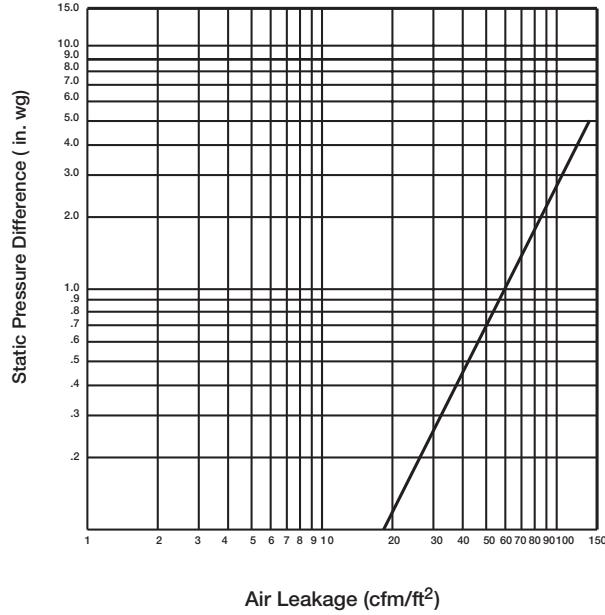

Velocity Limitations

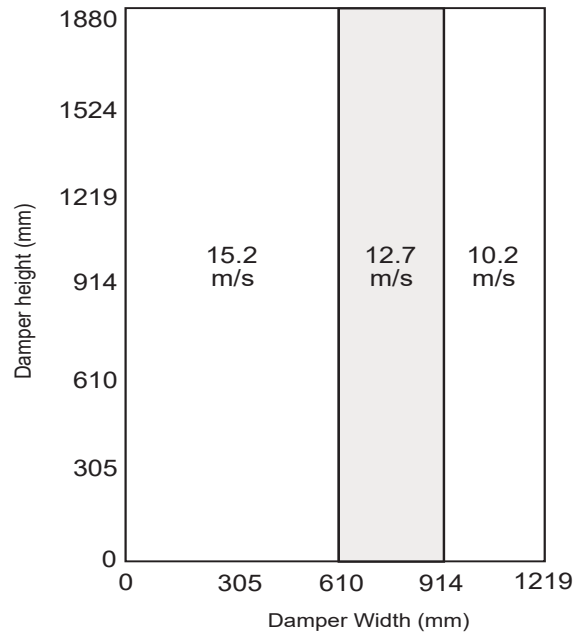
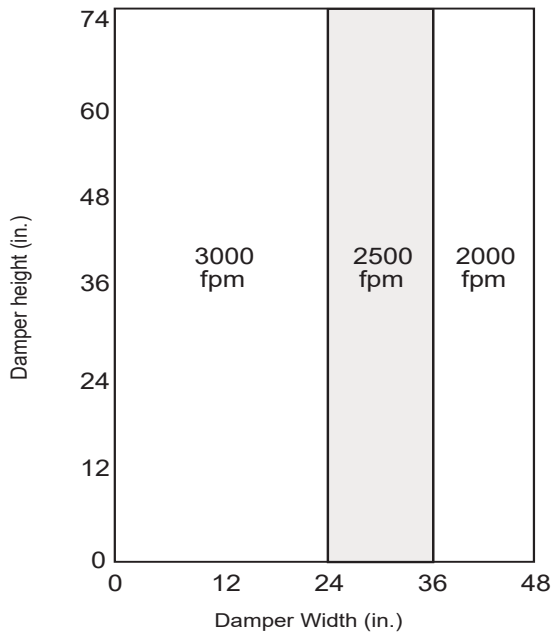

Space Envelopes

On dampers less than 18 in. (457 mm) high, actuators may also require clearances above and/or below the damper frame. **“B” and “T” dimensions are worst case clearance requirements for some dampers less than 18 in. (457 mm) high.** All damper sizes under 18 in. (457 mm) high do not require these worst case clearances. If space availability above or below the damper is limited, each damper size should be individually evaluated.

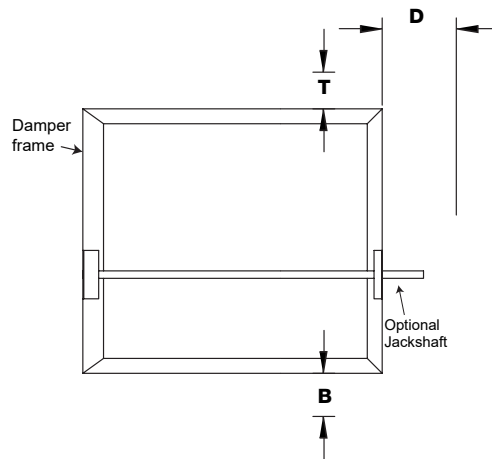

| Actuator Type/Model | Height Inches (mm) | T | B Inches (mm) | D |
|---|------------------------------|---|------------------|----------|
| AFBUP (-S) and FSNF Series, Belimo MSxx20 Series, Honeywell | ≥6 to <10 (≥152 to <254) | 0 | 12¾ (324) | 6¼ (159) |
| | ≥10 to <18 (≥254 to <457) | 0 | 2 (51) | 6¼ (159) |
| | ≥18 (457) | 0 | 0 | 6¼ (159) |
| FSLF, LF and TFB Series, Belimo | ≥6 to <10 (≥152 to <254) | 0 | 3½ (89) | 6¼ (159) |
| | ≥10 (≥254) | 0 | 0 | 6¼ (159) |
| MSxx04 & MSxx09 Series, Honeywell | ≥6 to <9 (≥152 to <229) | 0 | 4¾ (121) | 6¼ (159) |
| | ≥9 (229) | 0 | 0 | 6¼ (159) |
| MS75xx Series, Honeywell | ≥6 to <10 (≥152 to <254) | 0 | 12¾ (324) | 6¼ (159) |
| | ≥10 to <18 (≥254 to <457) | 0 | 7 (178) | 6¼ (159) |
| | ≥18 (457) | 0 | 0 | 6¼ (159) |
| GRD and GVD Series, Siemens | ≥6 to <10 (≥152 to <254) | 0 | 12¾ (324) | 6¼ (159) |
| | ≥10 to <18 (≥254 to <457) | 0 | 2 (51) | 6¼ (159) |
| | ≥18 (457) | 0 | 0 | 6¼ (159) |
| GJD Series, Siemens | ≥6 to <10 (≥152 to <254) | 0 | 3½ (89) | 6¼ (159) |
| | ≥10 to <18 (≥254 to <457) | 0 | 0 | 6¼ (159) |
| | ≥18 (457) | 0 | 0 | 6¼ (159) |

Actuator Mounting

Actuators may be installed at the factory, shipped loose with the necessary linkage and brackets for mounting, or field supplied. For more detail information on actuator mounting, click on link below or scan QR code.



[ACTUATOR MOUNTING](#)

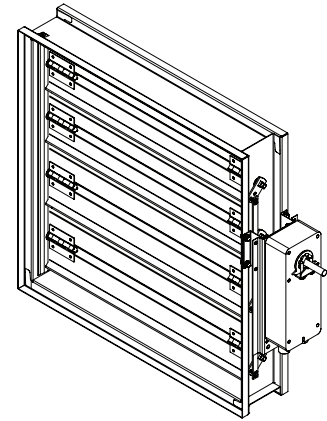

Non-jackshaft external right

Clearance Requirements

This drawing depicts the worse case clearance requirements for an actuator with a jackshaft.

| Internal mount only Actuator model | A | B | C |
|---------------------------------------|----------------------|---------------------|------------------------|
| All except - EFB & EFCX Series | 7 3/4 in (197 mm) | 3 3/4 in (95 mm) | 5 3/8 in (136.5 mm) |
| EFB & EFCX Series | 8 1/2 in (216 mm) | 6 in (152 mm) | 8 1/2 in (216 mm) |

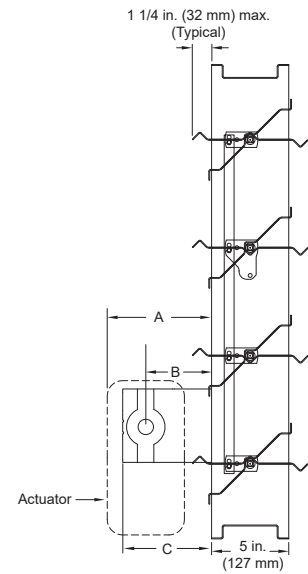

Multi-Section Dampers

Dampers larger than the maximum single section size, will be made up of a multiple of equal size sections.

NOTE: Dampers larger than 48 in. x 74 in. (1219 mm x 1880 mm) are not intended to be structurally self supporting. Refer to IOM document 463384 for structural support requirements on multi-section assemblies.

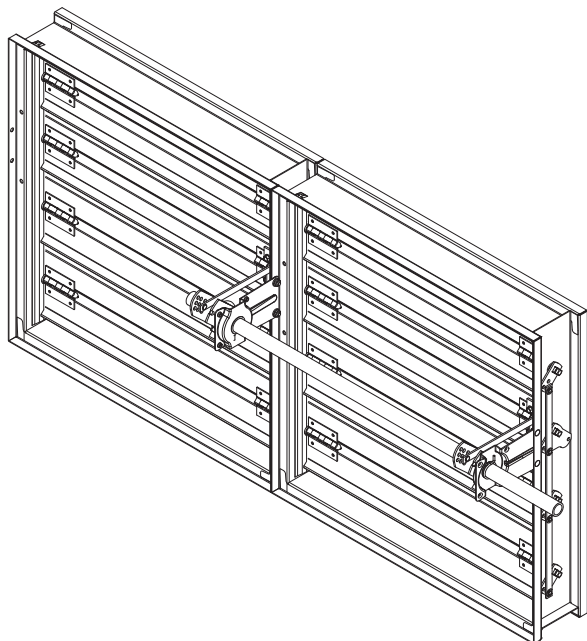

2 section example shows single jackshaft driving multiple sections

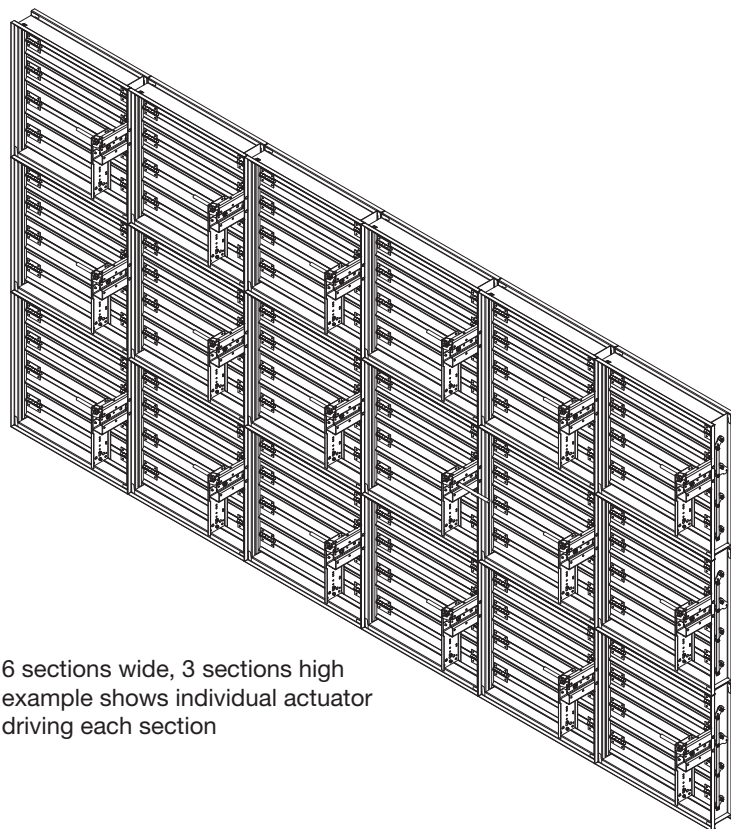

6 sections wide, 3 sections high example shows individual actuator driving each section

Document Links



[INSTALLATION](#)



[CATALOG](#)



[SELECTION GUIDE](#)



[SPECIFICATIONS](#)



[WARRANTY](#)