

FSD Series

Inline Mixed Flow Fan

Certifications:



Fantech Inc. certifies that the FSD series shown herein is licensed to bear the AMCA seal. The ratings shown are based on tests and procedures performed in accordance with AMCA Publication 211 and AMCA Publication 311 and comply with the requirements of the AMCA Certified Ratings Program.

Dimensional Table (in inches (mm)):

Model	A	B
FSD 18	15 3/4 (400)	17 5/8 (448)
FSD 20	17 3/4 (451)	19 3/4 (502)
FSD 22	19 (483)	21 1/2 (546)
FSD 26	20 (508)	26 (660)

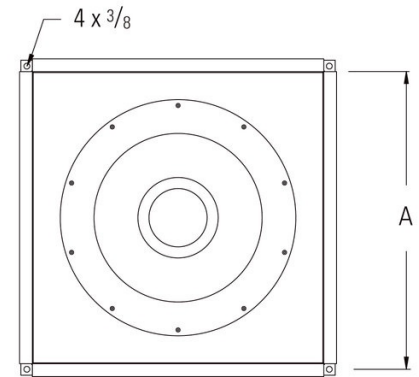
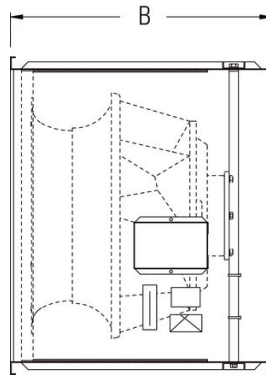

Performance Data:

Certified Data

Model	Rated Power (W)	Voltage (V/-)	Max Amps (A)	RPM (min ⁻¹)	0.0"Ps	0.5"Ps	0.75"Ps	1.0"Ps	1.5"Ps	2.0"Ps	LwA at 0.5" Ps (dB(A))	Item #
					CFM							
FSD 18	547	120/1	4.40 ²	1640	2496	2160	1889	1625	360	-	70.0	498353
FSD 20	791	120/1	6.2 ²	1500	2980	2493	2178	1833	1069	68	75.0	498355
FSD 22	1828	120/1	13.1 ³	1600	4586	4174	3880	3606	3080	2152	81.0	498357
FSD 26	3076	230 460/3	7.4 4.3	1700	7192	6772	6625	6401	5788	5265	87.0	498359

Performance shown is for installation type A: Free inlet, Free outlet. Speed (RPM) shown is nominal. | Performance is based on actual speed of test. Performance ratings do not include the effects of appurtenances (accessories). | Values shown are for inlet LwA sound power levels for installation type A: Free inlet, Free outlet. | The sound ratings shown are Full Octave, A-weight, Sound Power values at 0.5 in.wg. Calculated per AMCA International Standard 301 | Note: Three phase motors are 230/460v. Motors are prewired 460v, may be ordered as 230v or be rewired in the field.