

# HMD

Direct Fire Heated  
Make-Up Air Unit

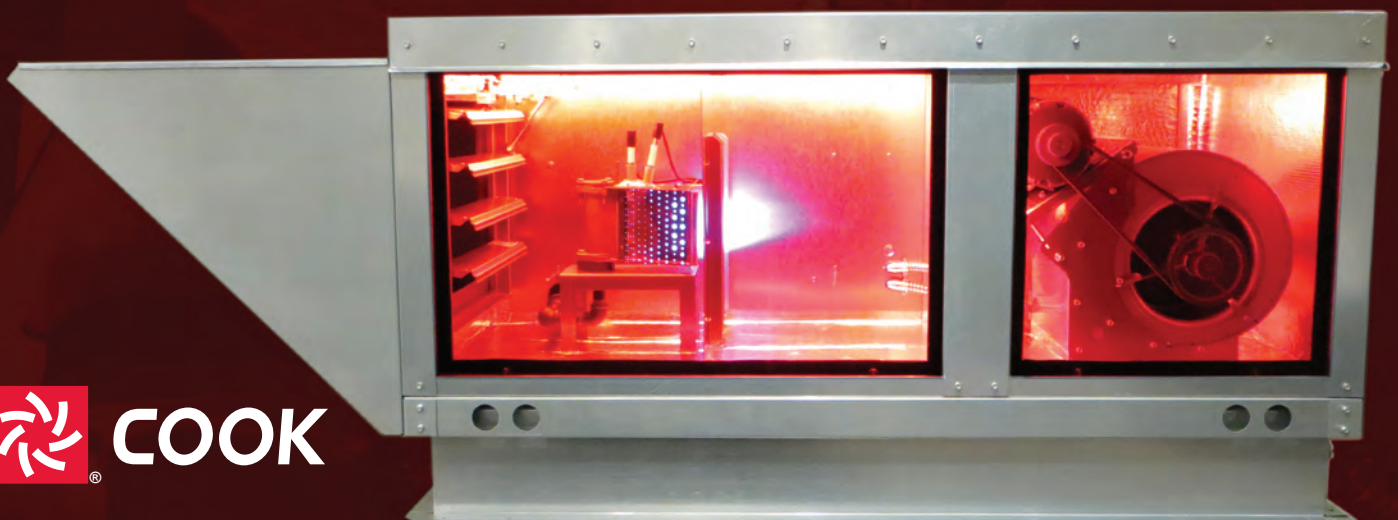

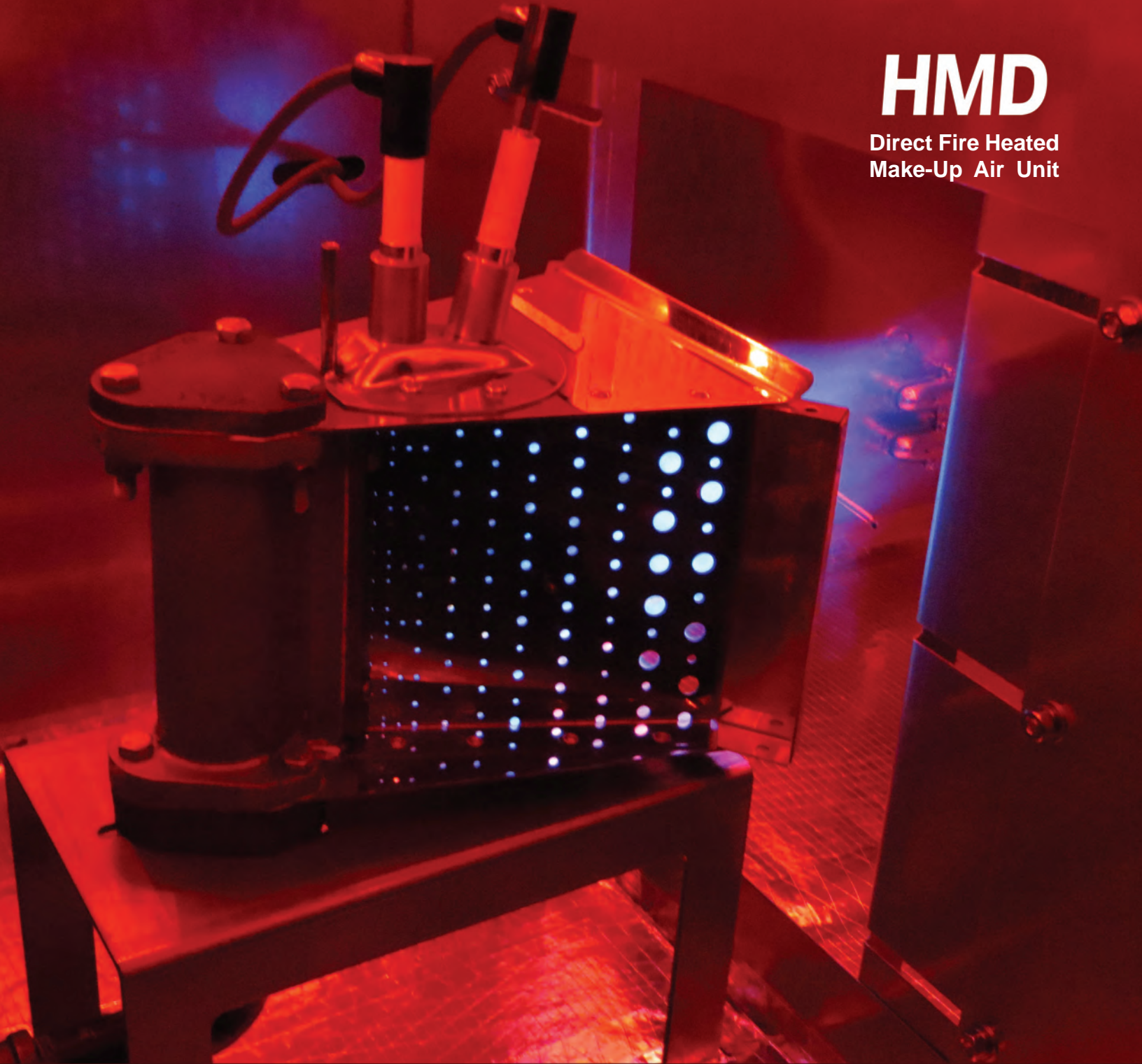

## Contents:

	Page
Construction Features	2 - 3
Specifications	4
Dimensions	5
Accessories	6
Air Performance Data	7
Sound Data	8

## HMD: Direct Fire Heated Make-Up Air Unit

Loren Cook Company's HMD product line offers outstanding performance and durability for direct fire make-up air applications.

Direct fire units offer the highest heating efficiency possible by having the flame directly in the airstream, creating no efficiency losses from heating a tube or plenum.

Applications include:

- Kitchen or food service
- Parkways
- Skywalks
- Light industrial
- Wherever tempered make up air is required.

The HMD offers industry leading standard features in a "package system" that contains features that are optional from all other competitors. The rugged yet simple design of the unit provides low maintenance and superior performance. The standard controls offer flexibility for future integration and are extremely user friendly, with optional remote display.

### There are three models:

Model	CFM Range		Propane		Natural Gas	
	Min	Max	Max. Temp. Rise	Max. MBH *	Max. Temp. Rise	Max. MBH *
HMD-2400	680	2400	84°F	251	100°F	299
HMD-3400	2000	3400	76°F	322	94°F	398
HMD-4100	3000	4100	78°F	398	91°F	464

\*Based on an altitude of 0 feet & an air temperature of 0°F



Loren Cook Company certifies that the HMD shown herein is licensed to bear the AMCA Seal. The ratings shown are based on tests and procedures performed in accordance with AMCA Publication 211 and AMCA Publication 311 and comply with the requirements of the AMCA Certified Ratings Program.



HMD is ETL certified for US and Canada to the ANSI Z83.4&CSA 3.7 standard -2003 for 100% Non-Recirculating Direct Gas-Fired Industrial Air Heaters and meet Factory Mutual Insurance requirements

When exhaust air leaves the building, it must be replaced. Without proper design, air will enter in the form of a draft. The HMD supplies heated outside air, at a controlled rate, keeping the temperature comfortable.

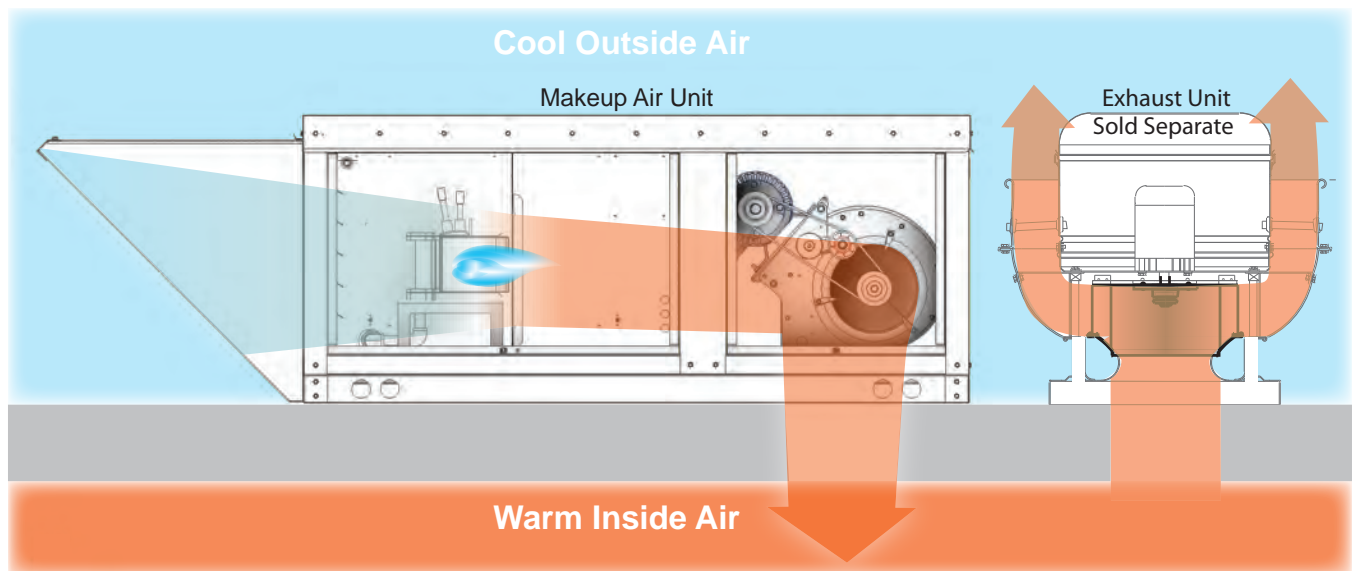

Curb, duct work and hood not shown.

## Standard Features

- Natural gas or propane fueled
- Housing constructed of minimum 18 gauge G90 galvanized steel
- Removable access panels
- Weatherization
- Cabinet lined with 1" thick 3 lb density FSK insulation
- Corrosion resistant fasteners
- Lifting points
- DWDI Forward curved steel blower mounted on vibration isolators
- Motorized intake damper
- Intake weather hood
- Permanent 1" thick washable aluminum filter
- Cast aluminum burner with stainless steel baffles
- Redundant gas valves
- Gauges for supply and manifold gas pressure
- Intermittent direct spark ignition system
- Electronic flame modulation
- Field adjustable profile plates
- Intake air temp sensor
- Mild weather stat
- Freeze protection
- Pre-wired and pre-piped controls
- Lockable disconnect switch
- Permanently lubricated bearings rated at 200,000 hours average life
- Adjustable motor pulley adjusted to specified RPM
- Static resistant belts
- Standard motors ship factory installed

## Additional Options:

- Remote Display Panel
- Belt Tensioner
- GFCI outlets
- Heater Interlock Relay
- Low/High Pressure Gas Switch
- Intake Extension
- Gas Pressure Regulator
- Variable Frequency Drive
- Filters:
  - Dirty Filter Sensor
  - Filter Box
  - Replacement Filters

## COOK's Package System vs the Competition

 **COOK**    Competition

	COOK	Competition
Washable Filters	Standard	Optional
Motorized Inlet Damper	Standard	Optional
NEMA 3 Lockable Disconnect	Standard	Optional
Freeze Protection	Standard	Optional
Mild Weather Stat	Standard	Optional
Inlet Air Sensor	Standard	Optional
Gas Pressure Gauges	Standard	Optional
Digital Discharge Controls	Standard	Optional
Direct Spark Ignition	Standard	Optional
Full Crating	Standard	Optional

## Standard Control Panel

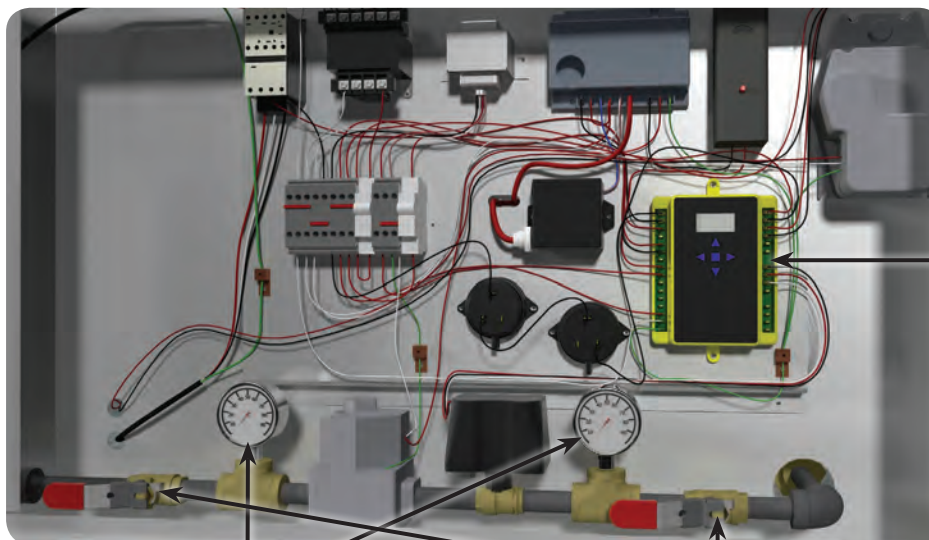

Dual Gas Pressure Gauges

Redundant Gas Valves

### Temperature Controller Including:

- Electronic Flame Modulation
- Mild Weather Stat
- Freeze Protection

## Horizontal discharge shown

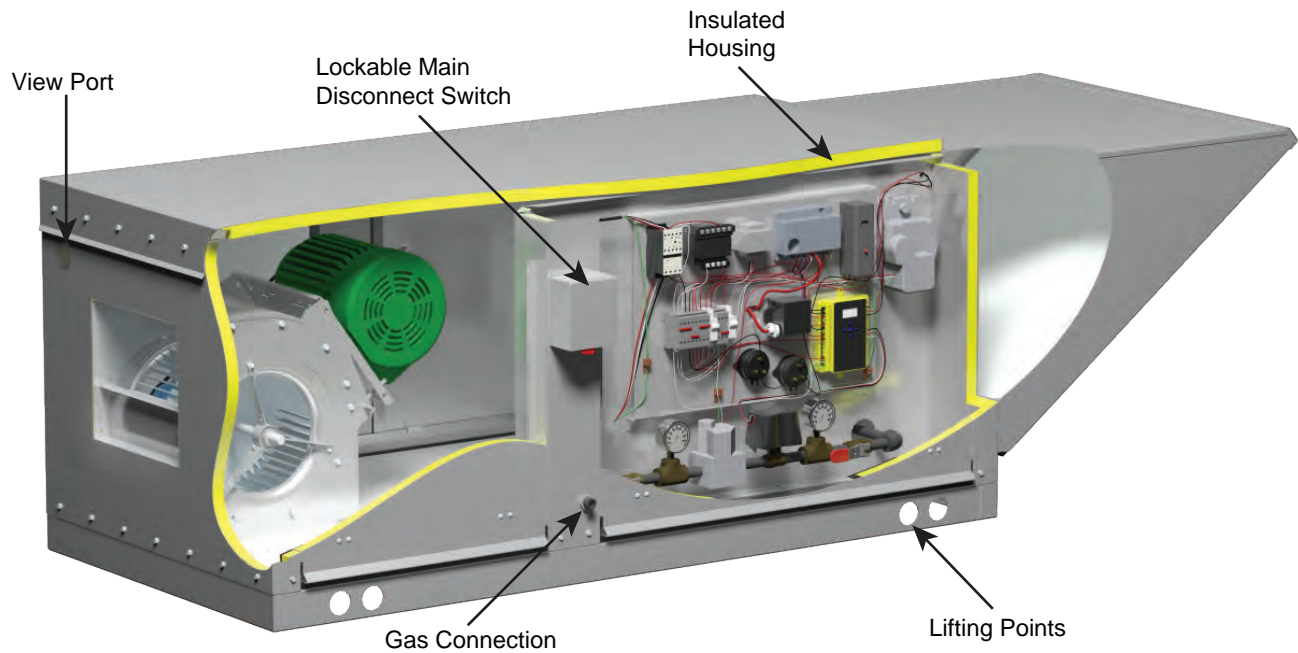
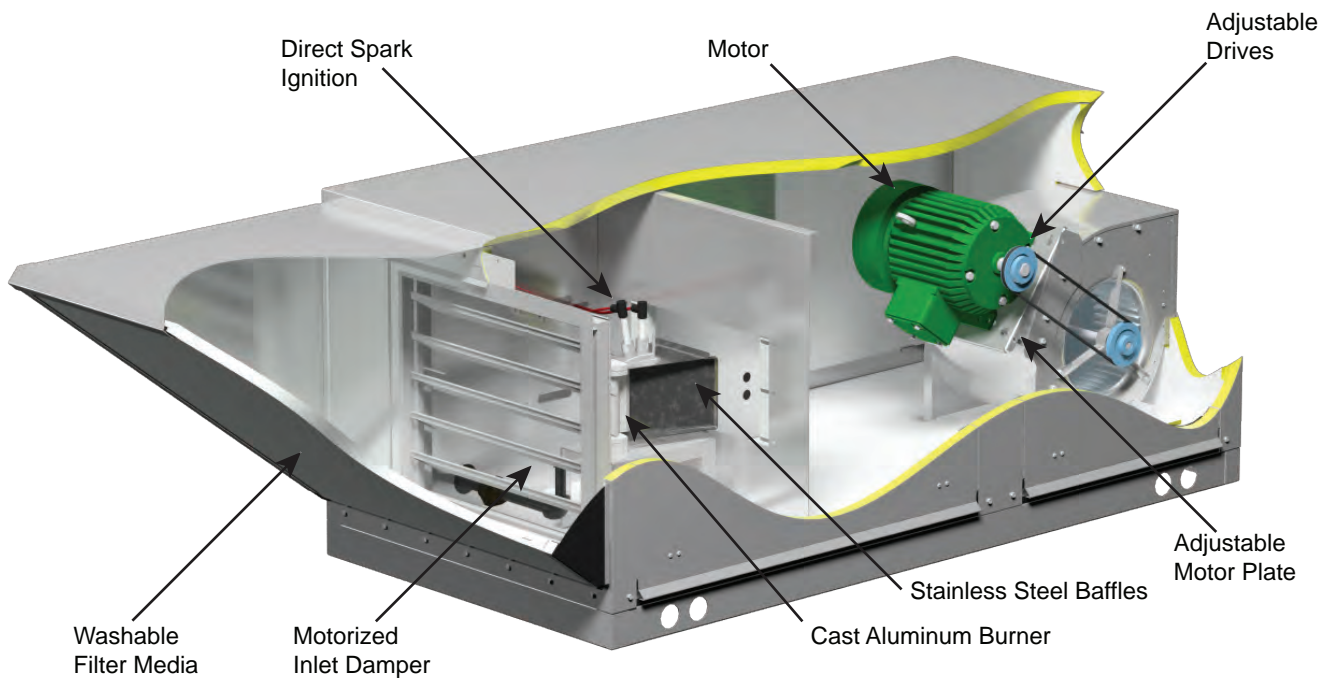



Loren Cook Company certifies that the HMD shown herein is licensed to bear the AMCA Seal. The ratings shown are based on tests and procedures performed in accordance with AMCA Publication 211 and AMCA Publication 311 and comply with the requirements of the AMCA Certified Ratings Program.



HMD is ETL certified for US and Canada to the ANSI Z83.4&CSA 3.7 standard -2003 for 100% Non-Recirculating Direct Gas-Fired Industrial Air Heaters and meet Factory Mutual Insurance requirements

## Direct Gas-Fired, Heated Make-Up Air Unit, Belt Driven

**Description:** Unit shall be a roof mounted, belt driven, direct gas-fired, heated make-up air unit.

**Certifications:** Unit shall be manufactured at an ISO 9001 certified facility. Unit shall be listed by ETL for US and Canada to ANSI Z83.4-2003 / CSA 3.7-2003 for 100% Non-Recirculating Direct Gas-Fired Industrial Air Heaters and meet Factory Mutual Insurance requirements. Unit shall bear the AMCA Certified Ratings Seal For Sound and Air Performance.

**Construction:** The unit shall be of bolted construction utilizing corrosion resistant fasteners. Housing shall be minimum 18 gauge G90 galvanized steel, bolted to a minimum 14 gauge G90 galvanized steel unit base suitable for curb or flat mounting. The base shall include integral lifting holes. Unit shall be provided with an insulated housing and 1" washable permanent aluminum filters. Internal blower and motor assembly shall be mounted on rubber vibration isolators. Unit shall have removable panels for easy access to all essential components. Unit shall bear an engraved aluminum nameplate. Nameplate shall indicate design CFM, static pressure, maximum fan RPM, and all ANSI required burner information. Unit and gas train shall be factory assembled and tested prior to shipment. Unit shall be shipped in ISTA Certified Transit Tested Packaging.

**Burner:** Burner shall be a two stage combustion burner with cast aluminum manifold and stainless steel baffles capable of operation on Natural gas or Propane. Burner shall be non-clogging, with direct spark ignition and have minimum 30:1 turndown capability with no moving parts. Gas train shall include redundant shutoff valves, high and low gas pressure gauges, and stainless steel ball modulating valve.

**Controls:** Unit shall have single point wiring and lockable disconnect switch. Motor starter and controls shall be provide and sized for proper unit operation. Discharge temperature controls shall have digital display with integrated freeze protection and economizer/mild weather burner cutout.

**Wheel:** Wheel shall be DWDI centrifugal forward curved type, constructed of G90 galvanized steel. Wheel shall be balanced in accordance with AMCA Standard 204-05, Balance Quality and Vibration Levels for Fans.

**Motor:** Motor shall be NEMA design B with minimum class B insulation rated for continuous duty and furnished at the specified voltage, phase and enclosure.

**Bearings:** Bearings shall be ball type selected for a minimum L50 life in excess of 200,000 hours at maximum cataloged operating speed.

**Belts and Drives:** Belts shall be oil and heat resistant, static conducting. Drives shall be precision machined cast iron type, keyed and securely attached to the wheel and motor shafts. Drives shall be sized for 150% of the installed motor horsepower. The variable pitch motor drive must be factory set to the specified fan RPM.

**Product:** Unit shall be model HMD as manufactured by Loren Cook Company of Springfield, Missouri.

**Horizontal discharge**

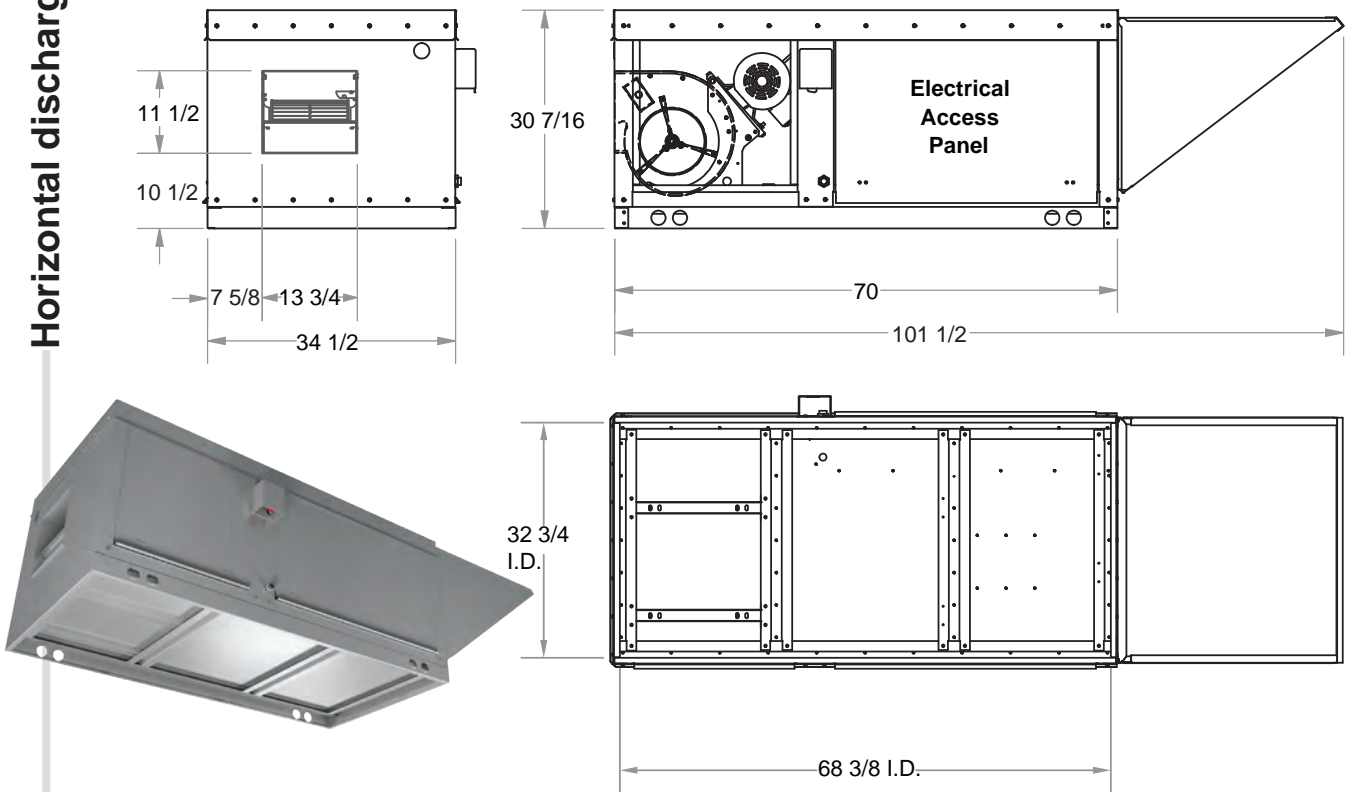

**Vertical discharge**

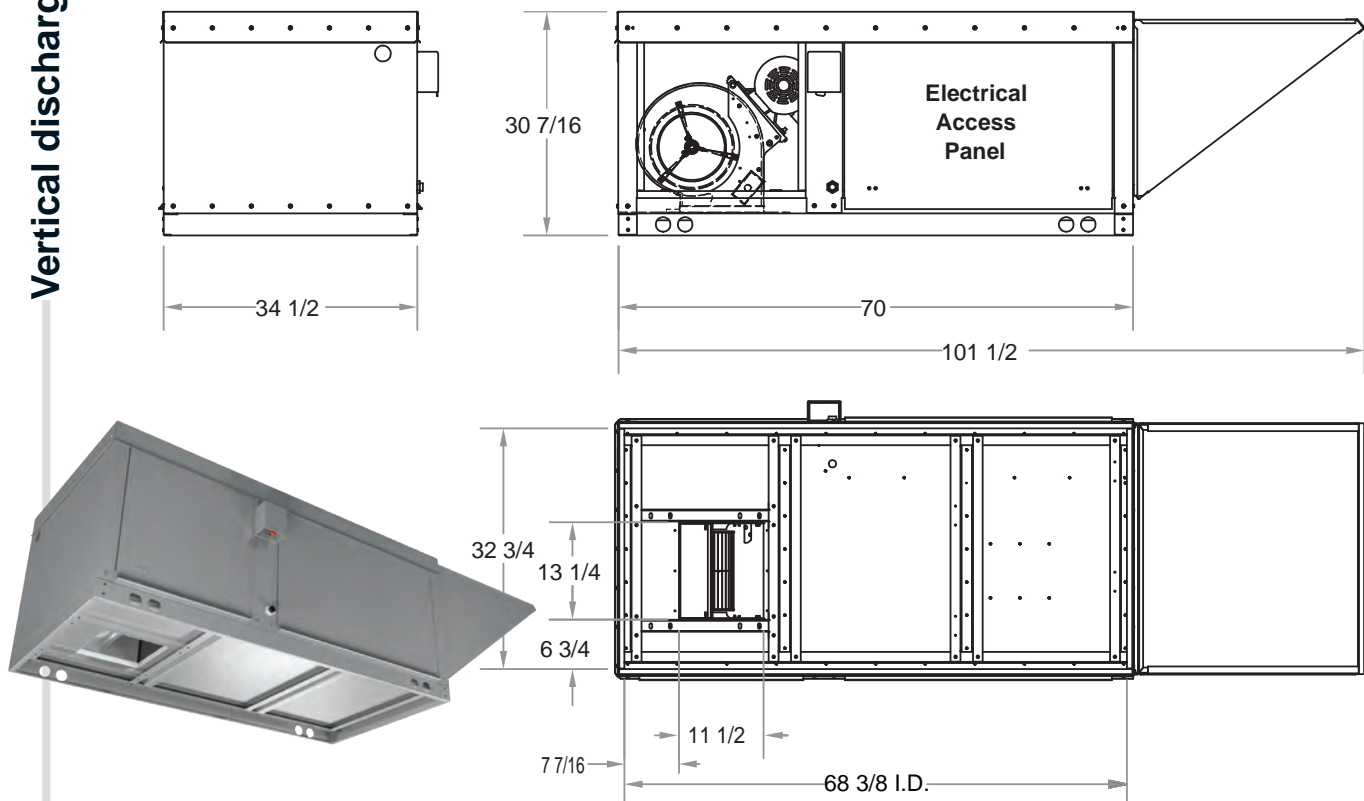

All dimensions in inches. Unit weight: 394 lbs., less motor, drives and accessories.

## Remote Display Panel

Enhanced remote digital control panel. The Remote Display Panel features a full color LCD which displays current HMD status as well as indoor, outdoor, discharge and indoor setpoint temperatures. Unit also has 7 day scheduling functions and diagnostics menus to aid in troubleshooting. The Remote Display Panel ships loose for field installation and requires a user supplied low-voltage 4-wire connection.



## Belt Tensioner

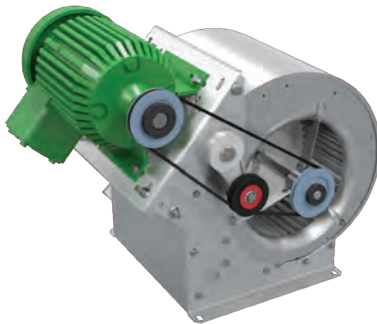

The automatic belt tensioner maintains constant tension on the drive belt which offers two distinct benefits. It reduces startup and maintenance costs by continuously tensioning the belt throughout its' life and also increases belt life by reducing slippage. Engineering studies indicate properly tensioned belts can operate at 15° to 20° F cooler internal temperature than poorly tensioned belts. A drive belt industry rule of thumb is that every 18° F increase in internal temperature will reduce belt life by 50%. The automatic belt tensioner will easily double belt life compared to installations where belt tension is not properly maintained. COOK's HMD has an easily removable access panel, providing tool free access to the automatic belt tensioner and motor compartment. The drive belt can be replaced in moments (by almost anyone) without the special skills and tools normally needed to achieve proper belt tension. Too much belt tension can reduce the life of both the fan and motor bearings. The COOK automatic belt tensioner will assure proper belt tension throughout the life of the fan, maximizing bearing life and fan reliability.

## GFI Outlet

NEMA 3R convenience outlet. Includes outlet and junction box. Shipped loose for field installation. Wiring and power supplied by others.

## Heater Interlock Relay

Field wired 24 volt relay (factory mounted in control panel) that allows the user to lock out the heating function of the unit while still allowing the makeup air fan to operate.

## Low/High Pressure Gas Switch

Field wired gas pressure switch (factory mounted in control panel) to notify BMS system of abnormally high or low gas pressure. Dry contacts rated for 120 volts. High and Low pressure switches are sold separately.

## Intake Extension

The intake extension is required in NFPA 96 installations where the HMD and VCR are mounted together on a common curb cap. The intake extension provides additional separation (10 feet) between the HMD intake hood and exhaust air from the VCR. The intake extension is constructed of galvanized steel and is shipped loose for field installation. The extension must be supported at the intake end by an equipment rail.

## Gas Pressure Regulator

Additional step down natural gas or propane regulator mounted outside the unit to match the building gas pressure to the HMD gas pressure requirement. A regulator is available for building with gas pressure above .5 PSI (14" w.g.) Available in 0-5 PSI, 5-10 psi and 10-15 PSI ranges. Shipped loose for field installation.



## Filters

### Dirty Filter Sensor

Field wired pressure switch (factory mounted in control panel) used to notify BMS system when filter pressure drop exceeds set point and filters need to be replaced. Dry contacts rated for 120 volts. Requires field calibration during installation.

### Filter Box

Additional V-bank filter box used to provide additional intake air filtration. Available with MERV 8, 11 or 13 filters. Installed between unit and intake hood.

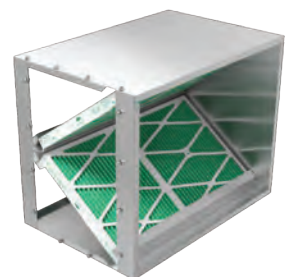

### Replacement Filters

Replacement filters for Filter Box. Set of 2. Specify MERV 8, 11 or 13.





Size	RPM	SP	Inlet / Outlet	Sound Power re 10 <sup>-12</sup> Watts									
				Octave Bands								L <sub>WA</sub>	
				1	2	3	4	5	6	7	8		
HMD-2400	400	0	Inlet	40	32	29	32	33	32	29	26	38	
			Outlet	58	55	53	51	50	47	42	37	55	
	750	0	Inlet	62	58	49	45	46	47	45	42	53	
			Outlet	76	72	68	66	65	63	60	55	70	
		0.25	Inlet	60	54	45	42	43	43	40	37	49	
			Outlet	74	68	65	63	61	59	54	48	66	
	1100	0.5	Inlet	59	53	46	45	46	44	41	37	51	
			Outlet	73	66	62	60	57	55	49	42	63	
		0.25	Inlet	71	72	62	52	52	53	53	50	62	
			Outlet	89	79	78	73	72	70	69	63	78	
	1450	0.5	Inlet	70	71	60	50	51	52	51	47	60	
			Outlet	89	78	76	72	71	68	67	60	76	
		0.75	Inlet	70	70	59	50	52	51	49	45	59	
			Outlet	88	76	73	69	68	66	64	57	74	
	1800	1	Inlet	69	69	58	52	54	53	50	47	60	
			Outlet	89	75	72	68	67	64	61	54	73	
		1.5	Inlet	74	76	68	59	57	58	58	55	67	
			Outlet	92	86	82	79	77	75	73	68	83	
	2000	2	Inlet	74	75	67	59	58	59	57	55	67	
			Outlet	93	85	80	76	74	72	70	64	80	
		3	Inlet	75	76	67	61	61	59	57	57	68	
			Outlet	94	85	80	76	74	72	69	64	80	
	HMD-3400	800	0	Inlet	80	81	72	62	65	64	63	61	72
				Outlet	100	89	86	80	79	77	75	70	86
1000		0.25	Inlet	81	82	72	63	66	65	64	63	73	
			Outlet	101	89	86	81	79	78	75	70	86	
		0	Inlet	65	62	54	48	49	50	50	48	57	
			Outlet	81	76	73	71	69	68	66	61	75	
1200		0.25	Inlet	71	70	63	53	53	55	55	53	63	
			Outlet	89	81	79	76	75	73	72	68	81	
		0	Inlet	69	69	62	51	51	52	53	50	61	
			Outlet	88	79	77	74	72	71	69	64	78	
1400		0.5	Inlet	76	76	70	58	57	59	60	58	68	
			Outlet	94	86	84	80	79	78	77	73	85	
		0.25	Inlet	74	75	69	56	56	57	58	56	66	
			Outlet	94	84	82	79	78	76	75	70	84	
1600		0.5	Inlet	72	74	68	55	55	55	56	54	65	
			Outlet	93	83	81	77	76	74	73	68	82	
		0.75	Inlet	71	74	65	54	54	55	54	52	64	
			Outlet	92	82	79	75	74	71	70	65	80	
1800		1	Inlet	76	77	71	61	59	60	61	59	69	
			Outlet	95	89	85	82	81	79	78	74	87	
		1.5	Inlet	74	76	70	60	58	59	60	58	68	
			Outlet	94	88	84	81	79	78	76	72	85	
2000		2	Inlet	73	76	69	59	58	59	58	56	67	
			Outlet	93	87	83	79	78	76	74	70	84	
	2.5	Inlet	77	78	72	63	61	62	63	62	71		
		Outlet	97	91	87	84	83	81	79	76	89		
2400	3	Inlet	75	77	71	61	61	61	61	60	70		
		Outlet	95	89	85	82	81	78	76	72	86		
	3.5	Inlet	76	78	70	61	62	62	60	59	70		
		Outlet	95	87	82	78	76	75	72	67	83		
2800	4	Inlet	78	79	73	62	64	64	64	63	72		
		Outlet	98	89	88	83	85	81	79	75	89		
	4.5	Inlet	78	81	73	62	65	64	64	62	73		
		Outlet	98	88	86	80	80	78	76	71	86		
3200	5	Inlet	80	82	76	65	66	66	67	65	75		
		Outlet	100	92	91	86	87	83	81	87	92		
	5.5	Inlet	80	83	77	65	67	66	66	65	75		
		Outlet	101	92	89	84	84	81	79	75	89		

Size	RPM	SP	Inlet / Outlet	Sound Power re 10 <sup>-12</sup> Watts								
				Octave Bands								L <sub>WA</sub>
				1	2	3	4	5	6	7	8	
HMD-4100	1200	0	Inlet	76	76	69	57	57	58	60	58	68
			Outlet	94	85	84	80	80	78	77	73	86
		0.25	Inlet	74	75	69	56	56	57	58	56	66
			Outlet	93	84	82	79	78	76	75	71	84
	1400	0	Inlet	78	79	72	63	60	62	63	62	71
			Outlet	96	90	87	84	84	82	81	77	89
		0.25	Inlet	77	78	72	62	59	61	62	61	70
			Outlet	95	89	86	83	82	81	79	76	88
	1600	0.5	Inlet	76	77	71	61	59	60	61	60	69
			Outlet	95	88	85	82	81	80	78	74	87
		0.75	Inlet	74	76	70	60	58	59	60	58	68
			Outlet	94	88	84	81	80	78	77	73	86
	1800	0.5	Inlet	79	80	74	64	62	64	65	64	73
			Outlet	97	92	89	86	85	84	82	79	91
		0.75	Inlet	78	79	73	63	61	63	64	63	72
			Outlet	97	91	88	85	85	83	81	78	90
	2000	1	Inlet	77	78	72	62	61	62	63	62	71
			Outlet	96	90	87	84	84	82	80	76	89
		1.5	Inlet	75	77	71	61	61	62	62	60	70
			Outlet	95	89	85	82	81	79	77	73	87
	2400	1.5	Inlet	79	81	74	62	63	65	66	65	73
			Outlet	99	91	90	85	87	84	82	78	92
		2	Inlet	78	79	73	62	64	64	65	63	72
			Outlet	98	90	88	84	86	82	79	75	90
2800	2.5	Inlet	80	82	76	65	66	66	67	66	75	
		Outlet	101	93	91	86	88	84	82	78	92	
	3	Inlet	79	82	77	65	67	66	66	65	75	
		Outlet	100	92	89	84	84	81	79	75	89	

The sound power level ratings shown are in decibels referred to 10-12 watts calculated per AMCA Standard 301. The A-weighted sound ratings shown have been calculated per AMCA Standard 301. Values shown are for inlet L<sub>W</sub>, L<sub>WA</sub> and outlet L<sub>W</sub>, L<sub>WA</sub> sound power levels for Installation Type B: Free inlet, Ducted outlet. Inlet ratings do not include the effects of duct end correction. Outlet ratings include the effects of duct end correction.



## **LOREN COOK COMPANY**

2015 EAST DALE ST.  
SPRINGFIELD, MO 65803-4637

PHONE (417)869-6474

FAX (417)862-3820

[www.lorencook.com](http://www.lorencook.com)