

WONDER METALS CORPORATION

LOUVERS - DAMPERS - PENTHOUSES - BRICK VENTS

Fixed Blade Louver SDL-6

AMCA Standard 500-L-07 Air Performance - Pressure Drop Test

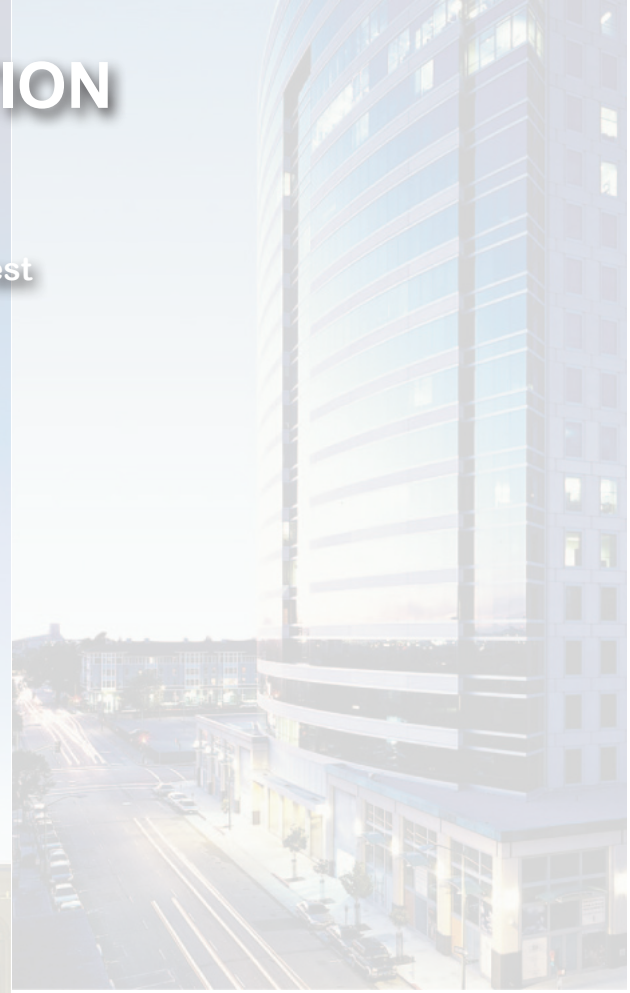

Architect/Engineer Remarks:

Project: _____

Location: _____

Architect: _____

Contractor: _____

Date: _____



WONDER METALS CORPORATION

"THE LOUVER PEOPLE"

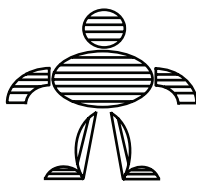

P.O. BOX 994427 REDDING, CA 96099-4427

800 336-5877

www.wondermetals.com

SDL-6 FIXED DRAINABLE LOUVER

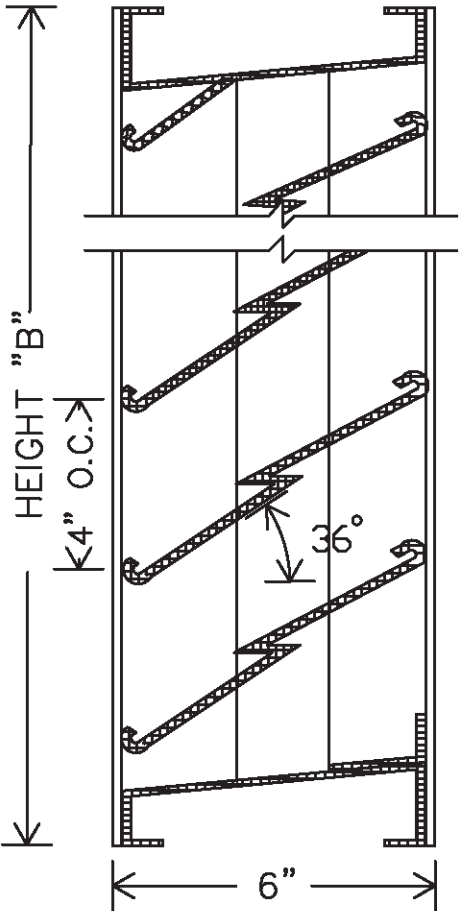

VERTICAL SECTION

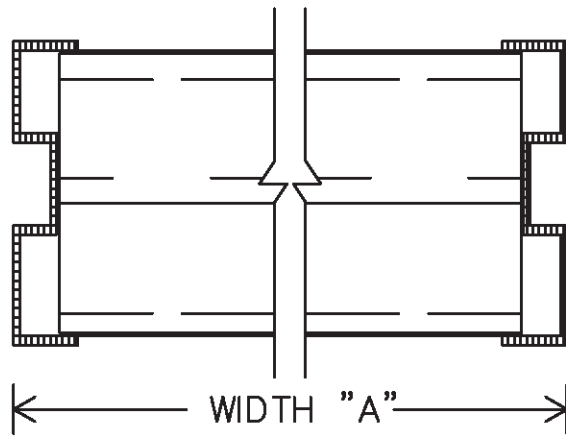

PLAN VIEW

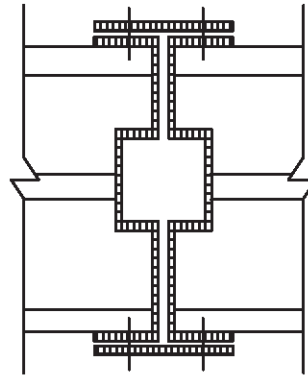

VERTICAL MULLION

AMCA 500
 W/P .01" @ 930 FPM
 P. S. .09" @ 930 FPM

LOUVERS TO BE 16 GA. GALVANIZED STEEL ALL WELDED CONSTRUCTED. MAXIMUM SINGLE SECTION SIZE NOT TO EXCEED 48" X 120" OR 40 SQUARE FEET. MULLIONS TO BE SUPPLIED WHERE WIDTH IS GREATER THAN 48". FREE AREA: 58%

ITEM	QTY.	DIMENSIONS				FINISHES	FEATURES
		OPENING		LOUVER			
		A	B	A	B		
						<input type="checkbox"/> MILL <input type="checkbox"/> PRIME COAT <input type="checkbox"/> BAKED ENAMEL <input type="checkbox"/> CLEAR ANODIZED <input type="checkbox"/> COLOR ANODIZED <input type="checkbox"/> KYNAR <input type="checkbox"/> OTHER (SPECIFY)	
						SCREEN <input type="checkbox"/> INTERIOR <input type="checkbox"/> EXTERIOR <input type="checkbox"/> 18 X 14 MESH INSECT <input type="checkbox"/> GALV. <input type="checkbox"/> 1/4" MESH BIRD <input type="checkbox"/> ALUM. <input type="checkbox"/> 1/2" MESH BIRD <input type="checkbox"/> STAINLESS <input type="checkbox"/> 3/4" GALVANIZED 16GA <input type="checkbox"/> OTHER	

PROJECT:
 LOCATION:
 CUSTOMER:

DATE:
 CONTROL #:
 SHEET OF

PHONE (800) 366-5877

www.wondermetals.com

FAX (530) 241-1738

LOUVERS
 &
 DAMPERS

WONDER METALS CORP.

REDDING
 CALIFORNIA

Wonder Metals Corp. certifies that the louver model SDL-6 shown herein is licensed to bear the AMCA Seal. The ratings shown are based on tests and procedures performed in accordance with AMCA Publication 511 and comply with the requirements of the AMCA Certified Ratings Program. The AMCA Certified Ratings Seal applies to air performance ratings and water penetration ratings only.



AMCA ratings seal applies to Air Performance and Water Penetration ratings tested in accordance with ANSI/AMCA 500-L Figure 5.5 -6.3

Published louver performance data bearing AMCA Certified Ratings Seal for Air Performance & Water Penetration must be submitted for approval prior to fabrication and must demonstrate pressure drop and water penetration equal to or less than WMC model specified.

WIDTH																				
	12	18	24	30	36	42	48	54	60	66	72	78	84	90	96	102	108	114	120	
12	0.35	0.53	0.70	0.88	1.05	1.23	1.40	1.58	1.75	1.93	2.10	2.28	2.45	2.62	2.80	2.97	3.15	3.32	3.50	
18	0.66	0.99	1.32	1.65	1.98	2.31	2.63	2.96	3.29	3.62	3.95	4.28	4.61	4.94	5.27	5.60	5.92	6.25	6.58	
24	0.98	1.47	1.96	2.45	2.94	3.43	3.89	4.39	4.88	5.37	5.85	6.34	6.83	7.31	7.80	8.29	8.77	9.26	9.75	
30	1.33	1.99	2.65	3.31	3.97	4.63	5.28	5.94	6.60	7.26	7.92	8.58	9.24	9.90	10.56	11.22	11.87	12.53	13.19	
36	1.62	2.43	3.24	4.05	4.86	5.67	6.54	7.32	8.14	8.96	9.77	10.59	11.41	12.22	13.04	13.86	14.67	15.49	16.31	
42	1.96	2.92	3.92	4.89	5.87	6.85	7.79	8.79	9.76	10.74	11.71	12.69	13.67	14.64	15.62	16.59	17.57	18.54	19.52	
48	2.32	3.48	4.64	5.80	6.96	8.12	9.35	10.48	11.65	12.82	13.98	15.15	16.32	17.49	18.65	19.82	20.99	22.16	23.32	
54	2.62	3.98	5.25	6.57	7.88	9.29	10.59	11.91	13.23	14.56	15.89	17.21	18.54	19.87	21.20	22.52	23.85	25.18	26.50	
60	2.95	4.44	5.90	7.38	8.86	10.33	11.84	13.30	14.78	16.26	17.74	19.21	20.69	22.17	23.65	25.13	26.61	28.09	29.56	
66	3.28	4.93	6.55	8.20	9.84	11.51	13.24	14.84	16.49	18.15	19.80	21.46	23.11	24.76	26.42	28.07	29.73	31.38	33.03	
72	3.60	5.43	7.21	9.02	10.82	12.66	14.18	16.10	17.88	19.66	21.44	23.22	24.99	26.77	28.55	30.33	32.11	33.89	35.67	
78	3.93	5.92	7.86	9.83	11.80	13.81	15.75	17.72	19.69	21.67	23.64	25.61	27.58	29.55	31.52	33.49	35.46	37.43	39.40	
84	4.26	6.41	8.52	10.65	12.78	14.96	17.15	19.25	21.39	23.54	25.68	27.83	29.97	32.11	34.26	36.40	38.55	40.69	42.83	
90	4.59	6.91	9.17	11.47	13.76	16.11	18.40	20.69	22.99	25.29	27.60	29.90	32.20	34.50	36.80	39.10	41.40	43.70	46.01	
96	4.91	7.40	9.82	12.29	14.74	17.26	19.80	22.22	24.69	27.17	29.64	32.12	34.59	37.07	39.54	42.02	44.49	46.97	49.44	
102	5.24	7.89	10.48	13.11	15.72	18.40	21.06	23.66	26.30	28.93	31.56	34.20	36.83	39.46	42.10	44.73	47.36	50.00	52.63	
108	5.57	8.38	11.13	13.92	16.71	19.55	22.31	25.10	27.89	30.69	33.48	36.27	39.06	41.85	44.64	47.43	50.22	53.01	55.81	
114	5.89	8.88	11.78	14.74	17.69	20.70	23.71	26.63	29.59	32.56	35.52	38.49	41.45	44.42	47.38	50.35	53.31	56.28	59.24	
120	6.22	9.37	12.44	15.56	18.67	21.85	24.97	28.08	31.20	34.32	37.44	40.57	43.69	46.81	49.94	53.06	56.18	59.31	62.43	

Free Area Chart

AMCA Standard 500 provides a reasonable basis for testing and rating louvers. Testing to AMCA 500 is performed under a certain set of laboratory conditions. This does not guarantee that other conditions will not occur in the actual environment where louvers must operate.

The louver system should be designed with a reasonable safety factor for louver performance. To ensure protection from water carryover, design with a performance level somewhat below maximum desired pressure drop and .01 oz./sq. ft. of water penetration.

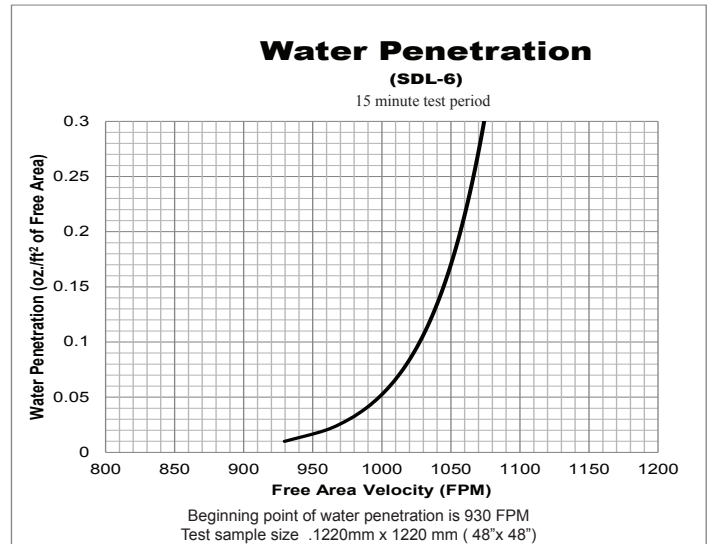
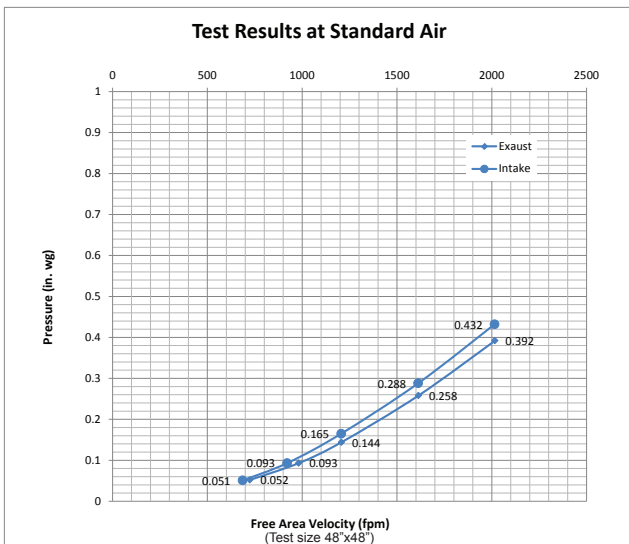

Wonder Metals certifies that WMC model SDL-6 is licensed to bear the AMCA seal. The ratings shown are based on test and procedures performed in accordance with AMCA Publication 511 and comply with the requirements of the AMCA certified ratings