

# 445RAAZ

## Stationary Acoustical Louver

Formed Steel



### APPLICATION

The 445RAAZ is a 4" deep acoustical louver designed to reduce the noise transmission between areas. This louver is specifically designed for weather protection of intake and exhaust exterior wall applications. It provides high free area and low airflow resistance with sound absorbing insulated blades for areas that require noise separation.

### STANDARD CONSTRUCTION

<b>Frame</b>	4" (102) deep, 16 gage (1.6) galvanized steel channel.
<b>Blades</b>	18 gage (1.3) galvanized steel exterior surface, with 22 gage (.9) perforated steel interior surface that covers insulation. Blades positioned at 45° angle and spaced approximately 6" (152) center to center.
<b>Insulation</b>	Ruskatherm blanket.
<b>Screen</b>	1/2" mesh x 19 gage (13 x 1.1) galvanized bird screen in removable frame. Screen adds approximately 1/2" (13) to louver depth.
<b>Finish</b>	Mill.
<b>Minimum Size</b>	12" w x 18" h (305 x 457).
<b>Approximate Shipping Weight</b>	5 lbs. per sq. ft.
<b>Maximum Factory Assembly Size</b>	Shall be 32 sq. ft. (3m <sup>2</sup> ). Maximum single section size shall be 48" x 96" (1219 x 2438). Louvers larger than the maximum single section size will require field assembly of smaller sections.

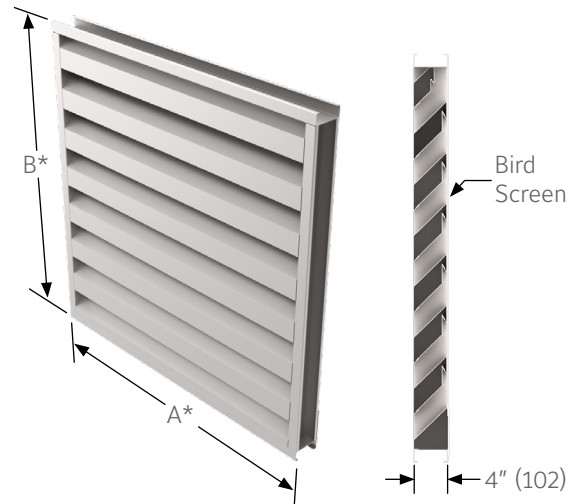

### FEATURES

- The 445RAAZ offers insulated blades which provide effective sound attenuation and weather protection with an architecturally pleasing appearance
- Publishes performance ratings based on testing in accordance with AMCA Publication 511

### VARIATIONS

Variations to the basic design of this louver are available at additional cost. They include:

- Extended sill
- Front or rear security bars
- Filter racks
- Installation angles
- Blank off panels
- Integral flange frame
- A variety of bird and insect screens
- Optional finishes available at additional cost: Prime coat, 50% PVDF (modified fluoropolymer), Epoxy, Pearledize, 70% PVDF, Clear and Anodized finishes. (Some variation in anodize color consistency is possible)
- Formed aluminum frame with .125" (3.2) nominal wall thickness and .080" (1.6) blade with .040" (1) perforated aluminum interior surface

Octave Band Frequency (Hz)	Free Field Noise Reduction (db) Ruskatherm Blanket
1/63	9
2/125	11
3/250	9
4/500	11
5/1000	15
6/2000	17
7/4000	16
8/8000	16

To calculate Transmission Loss (db), subtract 6 db from Free Field Noise Reduction (db).

#### NOTES:

- Dimensions in inches, parenthesis ( ) indicate millimeters.
- Units can be furnished actual size or with size deducts.

## PERFORMANCE DATA

AMCA Standard 500 provides a reasonable basis for testing and rating louvers. Testing to AMCA 500 is performed under a certain set of laboratory conditions. This does not guarantee that other conditions will not occur in the actual environment where louvers must operate.

The louver system should be designed with a reasonable safety factor for louver performance. To ensure protection from water carryover, design with a performance level somewhat below maximum desired pressure drop and .01 oz./sq. ft. of water penetration.

## FREE AREA GUIDE

Free Area Guide shows free area in ft<sup>2</sup> and m<sup>2</sup> for various sizes of 445RAAZ.

		Width – Inches and Meters								
		12 0.30	18 0.45	24 0.60	30 0.75	36 0.90	42 1.05	48 1.20	54 1.35	60 1.50
Height – Inches and Meters	18 0.45	<b>0.25</b> 0.02	<b>0.42</b> 0.04	<b>0.59</b> 0.05	<b>0.75</b> 0.07	<b>0.92</b> 0.09	<b>1.09</b> 0.10	<b>1.26</b> 0.12	<b>1.42</b> 0.14	<b>1.59</b> 0.15
	24 0.60	<b>0.38</b> 0.04	<b>0.63</b> 0.06	<b>0.88</b> 0.08	<b>1.13</b> 0.11	<b>1.38</b> 0.13	<b>1.63</b> 0.15	<b>1.88</b> 0.17	<b>2.14</b> 0.20	<b>2.39</b> 0.22
	30 0.75	<b>0.50</b> 0.05	<b>0.84</b> 0.08	<b>1.17</b> 0.11	<b>1.51</b> 0.14	<b>1.84</b> 0.17	<b>2.18</b> 0.20	<b>2.51</b> 0.23	<b>2.85</b> 0.26	<b>3.18</b> 0.29
	36 0.90	<b>0.63</b> 0.06	<b>1.05</b> 0.10	<b>1.47</b> 0.14	<b>1.88</b> 0.18	<b>2.30</b> 0.21	<b>2.72</b> 0.25	<b>3.14</b> 0.29	<b>3.56</b> 0.33	<b>3.98</b> 0.37
	42 1.05	<b>0.75</b> 0.07	<b>1.26</b> 0.12	<b>1.76</b> 0.16	<b>2.26</b> 0.21	<b>2.76</b> 0.26	<b>3.27</b> 0.30	<b>3.77</b> 0.35	<b>4.27</b> 0.40	<b>4.77</b> 0.44
	48 1.20	<b>0.88</b> 0.08	<b>1.47</b> 0.14	<b>2.05</b> 0.19	<b>2.64</b> 0.25	<b>3.22</b> 0.30	<b>3.81</b> 0.35	<b>4.40</b> 0.41	<b>4.98</b> 0.46	<b>5.57</b> 0.52
	54 1.35	<b>1.01</b> 0.09	<b>1.68</b> 0.16	<b>2.35</b> 0.22	<b>3.02</b> 0.28	<b>3.69</b> 0.34	<b>4.36</b> 0.41	<b>5.03</b> 0.47	<b>5.70</b> 0.53	<b>6.37</b> 0.59
	60 1.50	<b>1.13</b> 0.11	<b>1.88</b> 0.18	<b>2.64</b> 0.25	<b>3.39</b> 0.32	<b>4.15</b> 0.39	<b>4.90</b> 0.46	<b>5.65</b> 0.53	<b>6.41</b> 0.60	<b>7.16</b> 0.67
	66 1.65	<b>1.26</b> 0.12	<b>2.09</b> 0.19	<b>2.93</b> 0.27	<b>3.77</b> 0.35	<b>4.61</b> 0.43	<b>5.44</b> 0.51	<b>6.28</b> 0.58	<b>7.12</b> 0.66	<b>7.96</b> 0.74
	72 1.80	<b>1.38</b> 0.13	<b>2.30</b> 0.21	<b>3.22</b> 0.30	<b>4.15</b> 0.39	<b>5.07</b> 0.47	<b>5.99</b> 0.56	<b>6.91</b> 0.64	<b>7.83</b> 0.73	<b>8.75</b> 0.81
	78 1.95	<b>1.51</b> 0.14	<b>2.51</b> 0.23	<b>3.52</b> 0.33	<b>4.52</b> 0.42	<b>5.53</b> 0.51	<b>6.53</b> 0.61	<b>7.54</b> 0.70	<b>8.54</b> 0.79	<b>9.55</b> 0.89
	84 2.10	<b>1.63</b> 0.15	<b>2.72</b> 0.25	<b>3.81</b> 0.35	<b>4.90</b> 0.46	<b>5.99</b> 0.56	<b>7.08</b> 0.66	<b>8.17</b> 0.76	<b>9.25</b> 0.86	<b>10.34</b> 0.96
	90 2.25	<b>1.76</b> 0.16	<b>2.93</b> 0.27	<b>4.10</b> 0.38	<b>5.28</b> 0.49	<b>6.45</b> 0.60	<b>7.62</b> 0.71	<b>8.79</b> 0.82	<b>9.97</b> 0.93	<b>11.14</b> 1.04
	96 2.40	<b>1.88</b> 0.18	<b>3.14</b> 0.29	<b>4.40</b> 0.41	<b>5.65</b> 0.53	<b>6.91</b> 0.64	<b>8.17</b> 0.76	<b>9.42</b> 0.88	<b>10.68</b> 0.99	<b>11.93</b> 1.11
	102 2.55	<b>2.01</b> 0.19	<b>3.35</b> 0.31	<b>4.69</b> 0.44	<b>6.03</b> 0.56	<b>7.37</b> 0.69	<b>8.71</b> 0.81	<b>10.05</b> 0.93	<b>11.39</b> 1.06	<b>12.73</b> 1.18
	108 2.70	<b>2.14</b> 0.20	<b>3.56</b> 0.33	<b>4.98</b> 0.46	<b>6.41</b> 0.60	<b>7.83</b> 0.73	<b>9.25</b> 0.86	<b>10.68</b> 0.99	<b>12.10</b> 1.13	<b>13.53</b> 1.26
114 2.85	<b>2.26</b> 0.21	<b>3.77</b> 0.35	<b>5.28</b> 0.49	<b>6.78</b> 0.63	<b>8.29</b> 0.77	<b>9.80</b> 0.91	<b>11.31</b> 1.05	<b>12.81</b> 1.19	<b>14.32</b> 1.33	
120 3.00	<b>2.39</b> 0.22	<b>3.98</b> 0.37	<b>5.57</b> 0.52	<b>7.16</b> 0.67	<b>8.75</b> 0.81	<b>10.34</b> 0.96	<b>11.93</b> 1.11	<b>13.53</b> 1.26	<b>15.12</b> 1.41	

## PRESSURE DROP

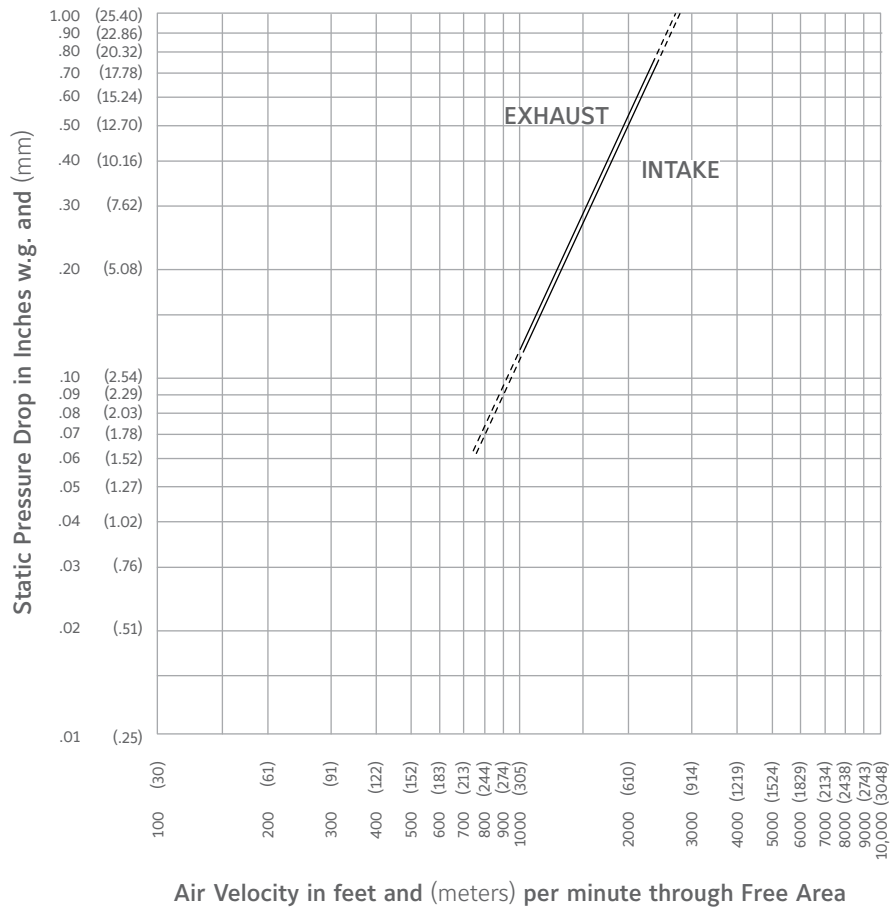

Ratings do not include the effect of a bird screen.

## WATER PENETRATION GRAPH

Test size 48" wide X 48" high (1219 X 1219)  
Beginning point of water penetration at .01 oz./sq. ft. is  
703 fpm (214 m/min).

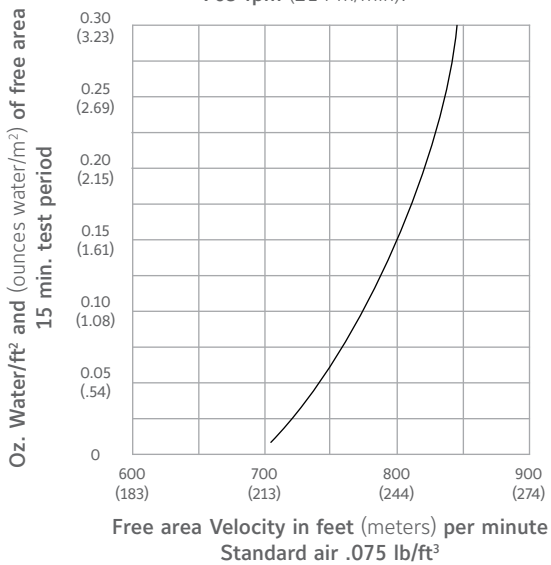

Ruskin Company certifies that the 445RAAZ Louvers shown herein are licensed to bear the AMCA Seal. The ratings shown are based on tests and procedures performed in accordance with AMCA Publication 511 and comply with the requirements of the AMCA Certified Ratings Program. The AMCA Certified Ratings Seal applies to air performance ratings and water penetration ratings only.

## TYPICAL INSTALLATION DETAILS

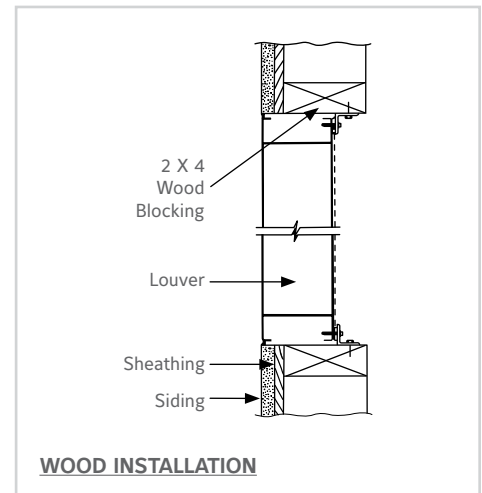
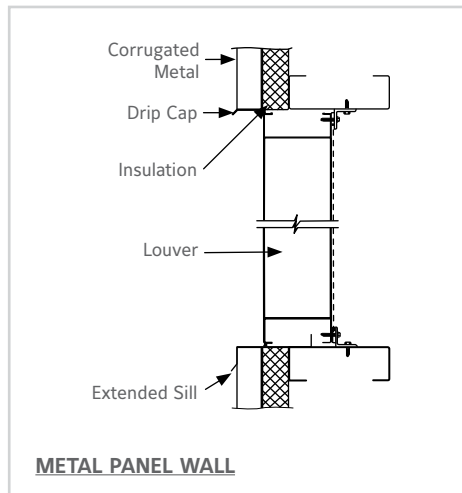
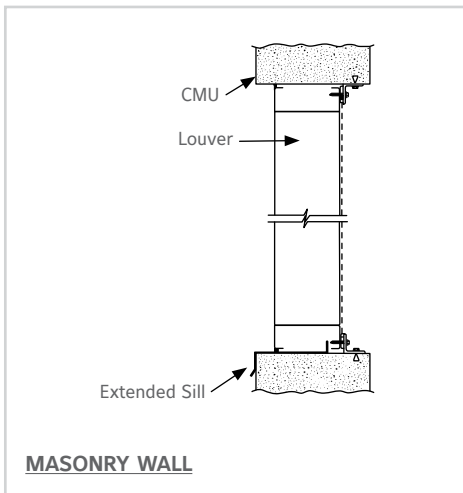

Accessories at additional cost.

## SUGGESTED SPECIFICATION

Furnish and install louvers as hereinafter specified where shown on plans or as described in schedules. Louvers shall be stationary acoustical type contained within a 4" (102) frame. Louver components (heads, jambs, sills, blades, and mullions) shall be factory assembled by the louver manufacturer. Louver sizes too large for shipping shall be built up by the contractor from factory assembled louver sections to provide overall sizes required. Louver design shall incorporate structural supports required to withstand a windload of 30 psf (1.44 kPa) (equivalent of a 110 mph (177 KPH) wind- specifier may substitute any loading required).

Louvers shall be Reliable Model 445RAAZ construction as follows:

Frame: 16 gage (1.6) galvanized steel channel.

Blades: 18 gage (1.0) galvanized steel exterior surface, 22 gage (.9) perforated steel interior surface that covers insulation. Blade angle 45° on 6" (152) centers.

Screen: 1/2" mesh x 19 gage (13 x 1.1) galvanized steel in removable frame.

Finish: Select finish specification from Reliable Finishes Brochure.

Published louver performance data bearing the AMCA Certified Ratings Seal for Air Performance must be submitted for approval prior to fabrication and must demonstrate pressure drop equal to or less than the Reliable model (by Ruskin Company) specified.

## LINKS TO IMPORTANT DOCUMENTS

### Document Title

Finishes and Color Guide

Limited Warranty Document

**RELIABLE**  
by **RUSKIN**

1300 Enterprise Road, P.O. Box  
580, Geneva, Alabama 36340  
Tel: 334-684-3621  
Tel: 800-624-3914  
Fax: 800-508-1469