

AXIAL FAN

MODEL: AAOM & SAOM

DLK[®]
VENTILATOREN



DLK VENTILATOREN SDN BHD certifies that the AAOM and SAOM series shown herein are licensed to bear the AMCA Seal.

The ratings shown are based on tests and procedures performed in accordance with AMCA Publication 211 and AMCA Publication 311 and comply with the requirements of the AMCA Certified Ratings Program.

[Product Brochure](#)

AAOM & SAOM Series

Introduction

DLK Asia has developed an agile and engineered product line to tackle ventilation at volumes large, small, dusty, roofed, and more. This is accomplished with our AAOM & SAOM models, letting the series meet your every purpose.

With this product lineup we can effectively provide extraction with ranges 360m³/hr - 216,000m³/hr, with static pressure rated for 1000 Pa.

Features

- Versatile Application
- Quality Construction
- Modularized Components
- GRN/ALU Blade Material
- Anti-static GRN
- Specialized Three-phase Motor
- Third Party Certificate on BS 7346, part 2: BS 1990 for Smoke Spill Application

Technologies

Impeller

Our line offer impeller blades constructed in either material: Glass Reinforced Nylon (GRN) and Aluminium (AL).

Glass Reinforced Nylon

Glass Reinforced Nylon 66 impellers boast greater strength, higher operating temperatures (-40°C to 150°C), and are able to operate at faster speeds (RPM).

Aluminium

Aluminium LM6 impellers offer the best solution for fume, and emergency smoke extraction (up to 400°C) in operating temperatures (-40°C to 200°C). Continuous operation is rated for -40°C to 200°C. Note, the maximum tip speed is 100m/sec.

Balancing

Fans and axial-impellers are balanced as per ISO Standard No. 1940 with a balancing grade of G2.5 and a Displacement Amplitude of 2.5mm/s

Casing Surface Finishing

Axial fan tube casing's surface use a paint – RAL 7030 via a powder coating method, with a coating thickness of 60µm. Thanks to this method we are able to produce fans with tube casings which appear with a “wrinkled” texture, providing increased protection against chemical and environmental wear.

Long case axial casings are rolled from 2.0mm to 5.0mm mild steel, a standard double-flanged L bracket mounting is provided, with a foot mounted support as an option. Tube casing comes with a standard view port and an access door can be requested as a further option.

Electric Motor

Our model uses a standard three phase motor (TEFC), foot mounted insulation is in accordance with IEC standard EN 60034, Enclosure IP55, with insulation Class “F”.

Reversed Airflow

Our series achieves a reversed air flow direction by reversing the direction of rotation, the impact on performance in this mode is as follows:

Volume Reduction: -40%

Pressure Reduction: -50%

Power Reduction: -35%

Performance for reversed airflow is not certified by AMCA.

Improved Reversible Airflow

For improved performance with reversed airflow: every other blade ought to be set in the opposite direction of flow, the new impact on performance in this mode is as follows:

Volume Reduction: -20%

Pressure Reduction: -35%

Power Reduction: -30%

Performance for improved reversed airflow is not certified by AMCA.

Contra-Rotating

A multi-stage axial fans with contra-rotating impellers are further options. A two stage contra-rotating assembly develops approximately 2.5 times the pressure developed by a single stage fan and increases the overall sound level by 8-10 dB.

To select a contra-rotating axial, divide the static pressure by 2.5 and select as though it was a single stage unit. The kW figure is for one stage only and should multiply 2 to the system.

Performance for contra-rotating is not certified by AMCA

Casing Dimensions



0315-0560



0630-1600(≤FS200)

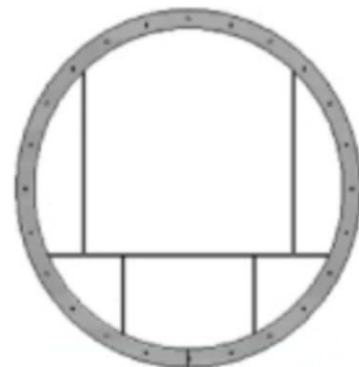

1120-1600(≤FS200)

Standard Arrangement

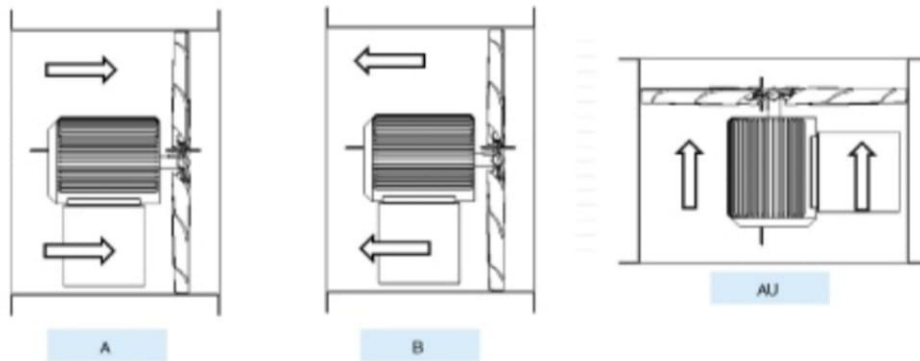

A = From motor to impeller

B = From impeller to motor

AU = From the motor to the impeller, up position

Form A and AU are not licensed by AMCA

Air Performance

Our series air performance ratings are derived from performance tests made with installation type “D” with a ducted inlet and outlet. These tests were carried out in accordance with DIN EN ISO 5801 and DIN 24166 with accuracy class 2. Ratings refer to standard air density.

Fan Balancing

Our Fan Balancing quality assurance is performed under DIN EN ISO 21940-11 grade G2.5

AAOM Series

Uses

Our **AAOM** series is the perfect solution when moving large volumes of stagnant air is your problem. Designed for use in general ventilation as well as large volume drying processes.



AAOM CAD DESIGN

Build

The build includes a heavy-gauge steel casing structure and a powder coated bake enamel finishing with the the option of galvanized steel.

Our high-efficiency impeller is made of adjustable pitch aerofoil blade: available in ALU or GRN type. Further options include foot mounting & hot-dipped galvanized casing.

Operating Temperature

The operating temperatures differs depending on your choice of GRN and ALU impeller types:

GRN: -40°C to 150°C

ALU: -40°C to 200°C

Motor

Three-phase motor which is "Totally Enclosed Fan Cooled" (TEFC), horizontal foot mounted Squirrel Cage Induction Motor, featuring a class F insulation.

Voltage supply of 400V/50Hz or 440V/60Hz.

All motors comply with standard IEC 60034 and BS 4999.

SAOM Series

Uses

Our SAOM incorporates the best in general ventilation but specializes for medium pressure and heavier particulates. Perfect for cases such as smoke extraction and removal of heavy particulates

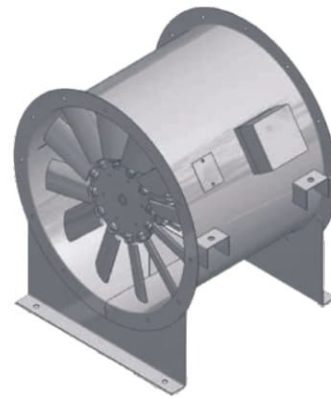

SAOM CAD DESIGN

Build

The build includes a heavy-gauge steel casing structure and a powder coated bake enamel finishing with the the option of galvanized steel.

Our high-efficiency impeller is made of adjustable pitch aerofoil blade: available in ALU or GRN type. Further options include foot mounting & hot-dipped galvanized casing.

Operating Temperature

Operating temperature differs between GRN and ALU impeller types:

GRN: -40°C to 150°C

ALU: -40°C to 200°C

Motor

Three-phase motor which is "Totally Enclosed Air Over" (TEAO), with a horizontal foot mounted Squirrel Cage Induction Motor, featuring a class H insulation.

Voltage supply of 400V/50Hz or 440V/60Hz.

All motors comply with standard IEC 60034 and BS 4999.

Specification

Hanger

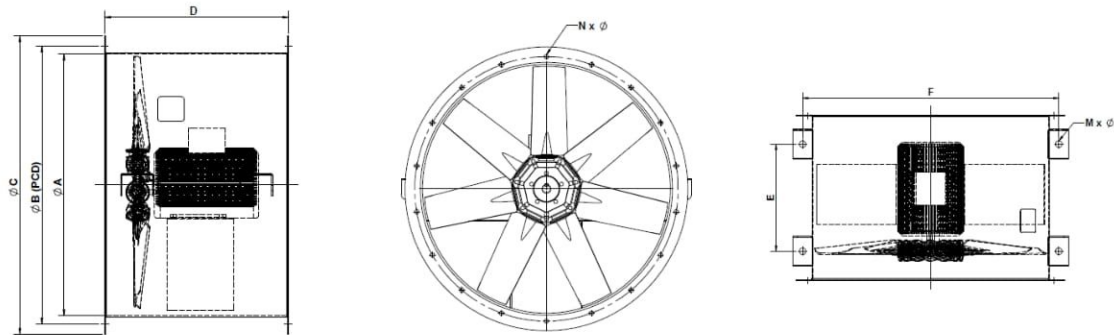

Mounting Feet (Optional)

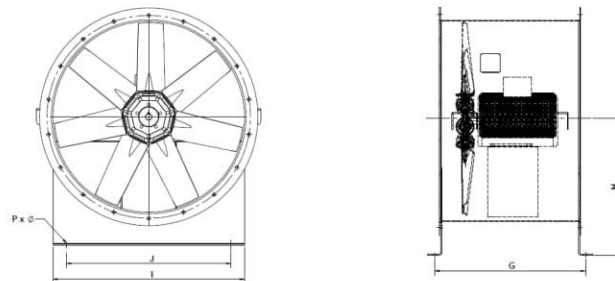

Dimensions Reference

MODEL	$\varnothing A$	$\varnothing B$ (PCD)	$\varnothing C$	D	$N \times \varnothing$	E	F	$M \times \varnothing$	G	H	I	J	$P \times \varnothing$	Frame
315	315	355	395	355	8 x 10	211	385	4 x 16	395	277.5	265	315	2 x 10	90
400	400	440	480	355	12 x 10	211	450	4 x 16	395	320	350	400	2 x 10	90
400	400	440	480	435	12 x 10	291	450	4 x 16	475	320	350	400	2 x 10	112
500	500	540	580	500	12 x 10	356	550	4 x 16	538	370	450	500	2 x 14	132
560	560	605	660	500	12 x 10	356	611	4 x 16	538	402.5	460	560	2 x 14	132
630	630	675	730	500	12 x 10	326	691	4 x 20	538	437.5	530	630	2 x 14	112
630	630	675	730	700	12 x 10	526	691	4 x 20	738	437.5	530	630	2 x 14	160
710	710	755	810	500	18 x 12	324	774	4 x 20	536	477.5	610	710	2 x 16	112
710	710	755	810	710	18 x 12	534	774	4 x 20	746	477.5	610	710	2 x 16	160
800	800	845	900	560	18 x 12	384	864	4 x 20	596	522.5	700	800	2 x 16	132
800	800	845	900	760	18 x 12	584	864	4 x 20	796	522.5	700	800	2 x 16	180
900	900	945	1000	630	18 x 12	454	964	4 x 20	666	592.5	800	900	2 x 16	132
900	900	945	1000	820	18 x 12	644	964	4 x 20	856	592.5	800	900	2 x 16	200
1000	1000	1045	1100	630	24 x 12	454	1065	4 x 20	666	672.5	900	1000	2 x 16	160
1000	1000	1045	1100	800	24 x 12	624	1065	4 x 20	836	672.5	900	1000	2 x 16	200
1120	1120	1185	1250	900	24 x 12	724	1185	4 x 20	936	742.5	1020	1120	2 x 16	225
1120	1120	1185	1250	1150	24 x 12	974	1185	4 x 20	1186	742.5	1020	1120	2 x 16	280
1250	1250	1315	1380	1000	24 x 12	794	1324	4 x 25	1084	807.5	1050	1250	3 x 20	250
1250	1250	1315	1380	1150	24 x 12	974	1324	4 x 25	1234	807.5	1050	1250	3 x 20	280

Performance Curve

AAOM 400-160-10B

50Hz 2880 rpm

SAOM 400-160-10B

Outlet Area: 0.127 m²

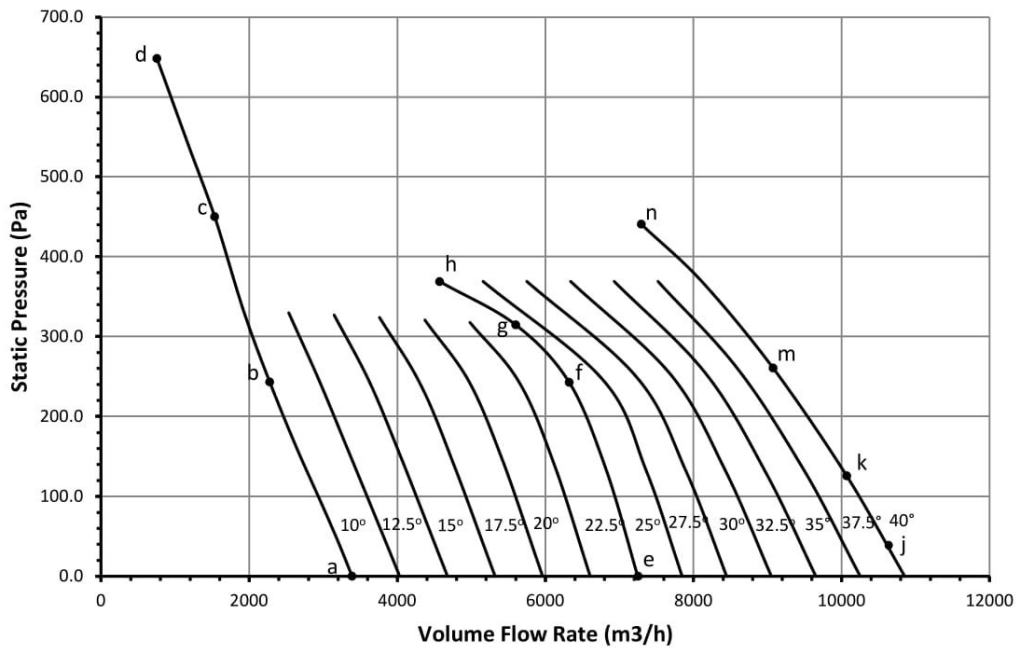
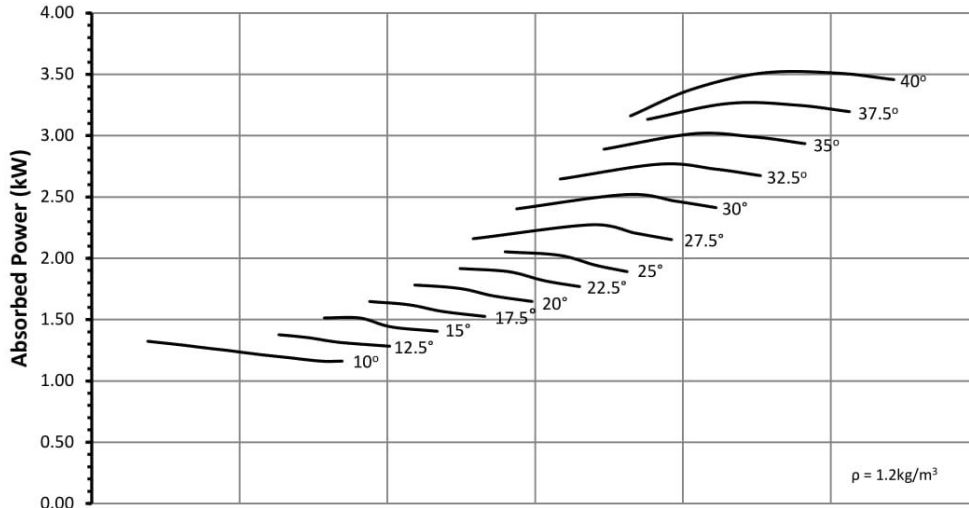

Ref	Full Octave Band Center Frequency								L _w A dB(A)
	63	125	250	500	1K	2K	4K	8K	
a	108	108	106	104	93	89	86	82	104
b	108	108	107	106	91	87	85	82	105
c	108	108	107	105	90	86	85	81	104
d	108	108	107	105	90	87	85	82	104
e	104	104	103	101	90	88	87	84	101
f	104	104	104	104	90	88	87	84	103
g	109	109	111	115	92	88	86	82	112
h	107	107	109	111	91	87	85	82	109
j	107	107	105	102	92	91	88	85	102
k	107	107	105	103	91	90	88	85	103
m	108	108	106	103	91	89	88	85	103
n	112	112	112	112	93	90	88	85	111



Performance certified is for Installation type D: Ducted Inlet-Ducted Outlet. Performance ratings do not include the effects of appurtenances (accessories)
 Power rating kW is fan input power.
 The Sound Power Level ratings shown are in decibels, referred to 10⁻¹² watts, calculated per AMCA International Standard 301. Values shown are for inlet L_{wi} and L_{wA} sound power levels for Installation type D: Ducted Inlet-Ducted Outlet. Ratings include the effects of duct end correction.
 The A-weighted sound ratings shown have been calculated per AMCA International Standard 301.

Performance Curve

AAOM 500-160-10B

50Hz 2880 rpm

FEG 50

SAOM 500-160-10B

Outlet Area: 0.200 m²

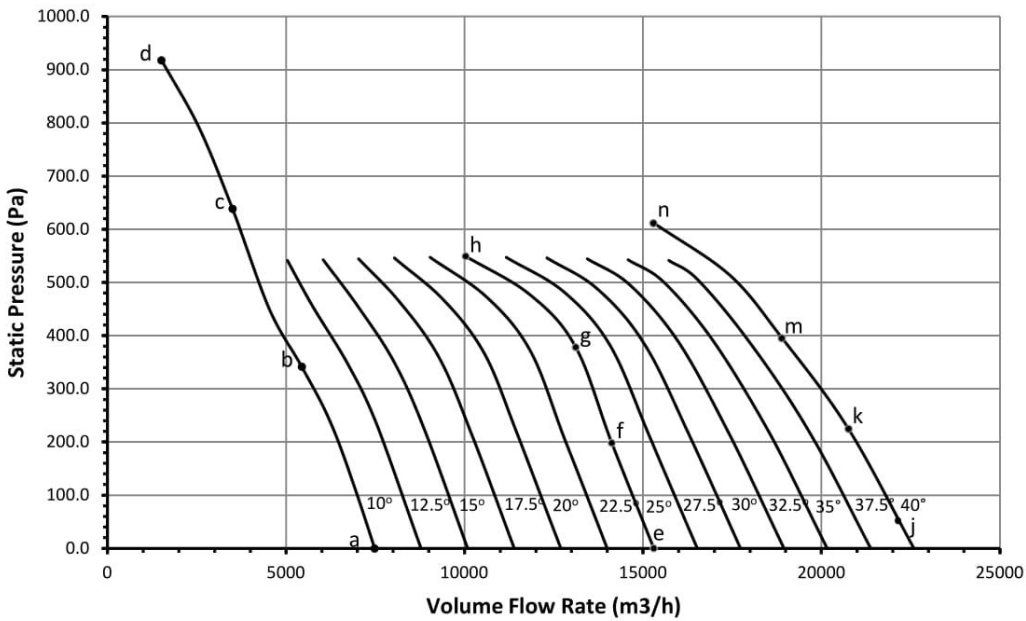
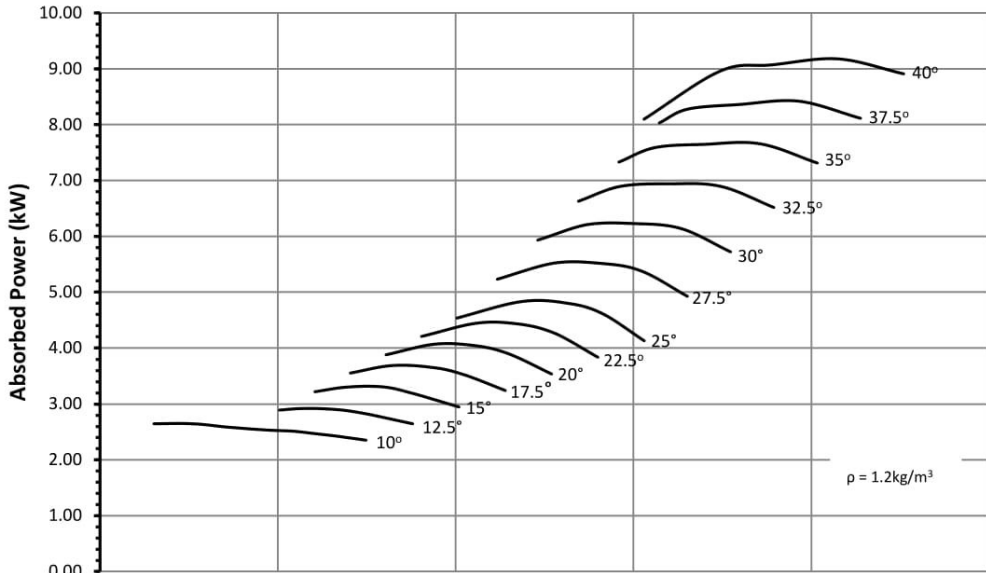

Ref	Full Octave Band Center Frequency								L _{WA} dB(A)
	63	125	250	500	1K	2K	4K	8K	
a	101	101	101	101	95	93	91	87	102
b	102	102	105	110	97	93	90	85	108
c	102	102	103	106	92	89	88	84	104
d	101	101	102	104	92	89	88	85	103
e	103	103	102	101	93	91	91	89	102
f	102	102	101	100	93	91	91	89	101
g	102	102	102	102	96	92	92	89	103
h	106	106	108	111	101	96	93	88	109
j	105	105	104	102	96	93	93	90	103
k	105	105	103	102	96	93	92	90	103
m	104	104	103	102	95	93	92	90	103
n	106	106	104	102	95	93	93	90	104



Performance certified for installation type D: Ducted Inlet-Ducted Outlet. Performance ratings do not include the effects of appurtenances (accessories)
 Power rating kW is fan input power.
 The Sound Power Level ratings shown are in decibels, referred to 10⁻¹² watts, calculated per AMCA International Standard 301. Values shown are for inlet L_{WA} and L_{WA} sound power levels for Installation type D: Ducted Inlet-Ducted Outlet. Ratings include the effects of duct end correction. The A-weighted sound ratings shown have been calculated per AMCA International Standard 301.

Performance Curve

AAOM 630-160-10B

50Hz 2880 rpm

FEG 60

SAOM 630-160-10B

Outlet Area: 0.317 m²

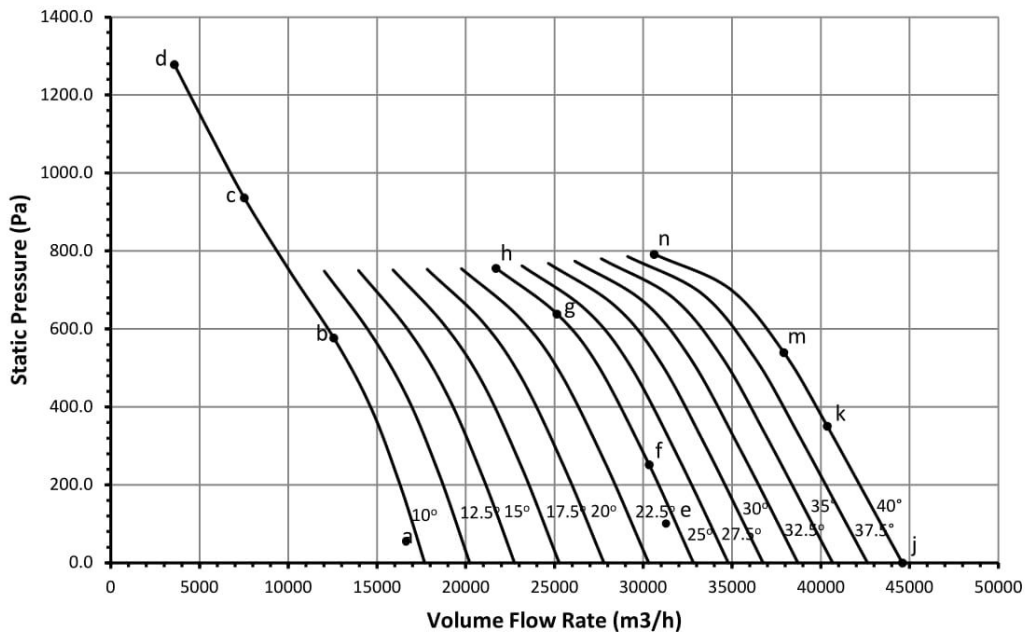
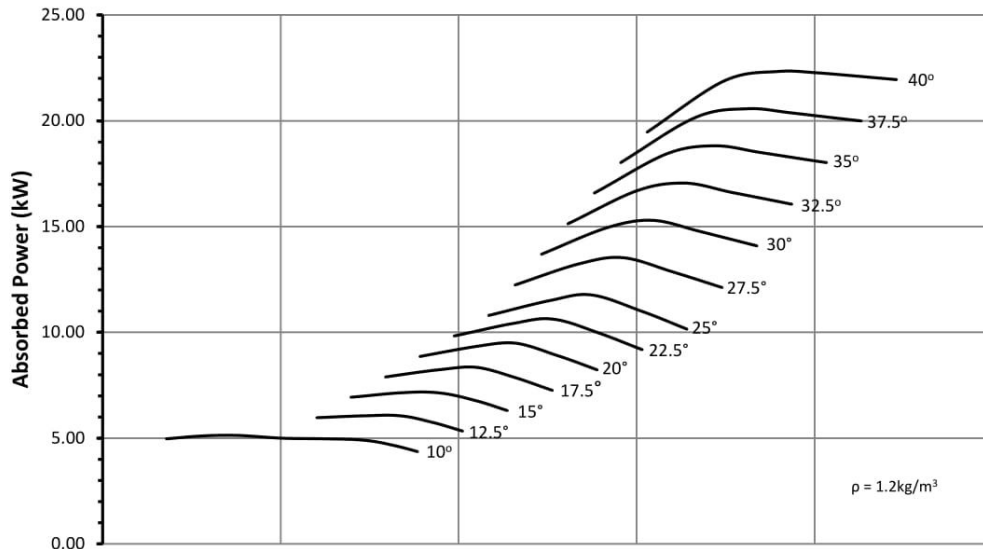

Ref	Full Octave Band Center Frequency							L _{WA} dB(A)	
	63	125	250	500	1K	2K	4K		8K
a	105	105	104	103	98	97	96	93	105
b	106	106	106	108	103	101	97	92	109
c	104	104	107	111	96	94	93	90	109
d	106	106	106	106	98	96	94	92	106
e	110	110	108	106	100	97	96	94	108
f	108	108	107	106	99	97	96	94	107
g	108	108	108	108	105	102	99	96	110
h	109	109	109	111	109	103	100	95	113
j	114	114	112	109	104	100	97	95	111
k	113	113	111	109	102	99	97	96	110
m	112	112	111	109	103	100	98	96	110
n	118	118	114	107	99	96	92	87	110



Performance certified is for Installation type D: Ducted Inlet-Ducted Outlet. Performance ratings do not include the effects of appurtenances (accessories)
 Power rating kW is fan input power.
 The Sound Power Level ratings shown are in decibels, referred to 10⁻¹² watts, calculated per AMCA International Standard 301. Values shown are for inlet L_{WA} and L_{WA} sound power levels for Installation type D: Ducted Inlet-Ducted Outlet. Ratings include the effects of duct end correction.
 The A-weighted sound ratings shown have been calculated per AMCA International Standard 301.

Performance Curve

AAOM 400-160-10B
SAOM 400-160-10B

50Hz 1440 rpm

Outlet Area: 0.127 m²

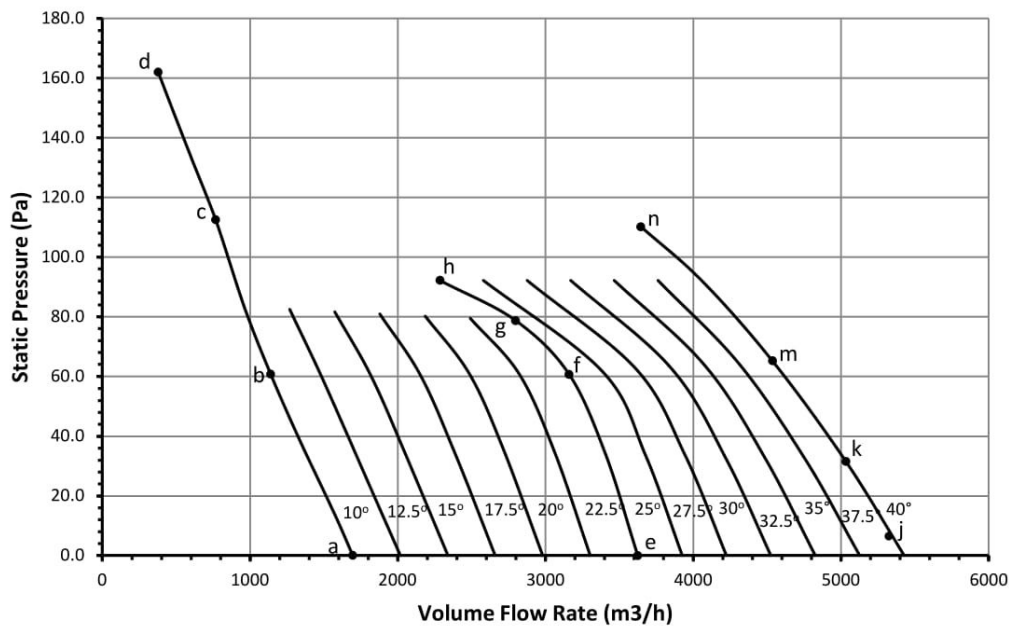
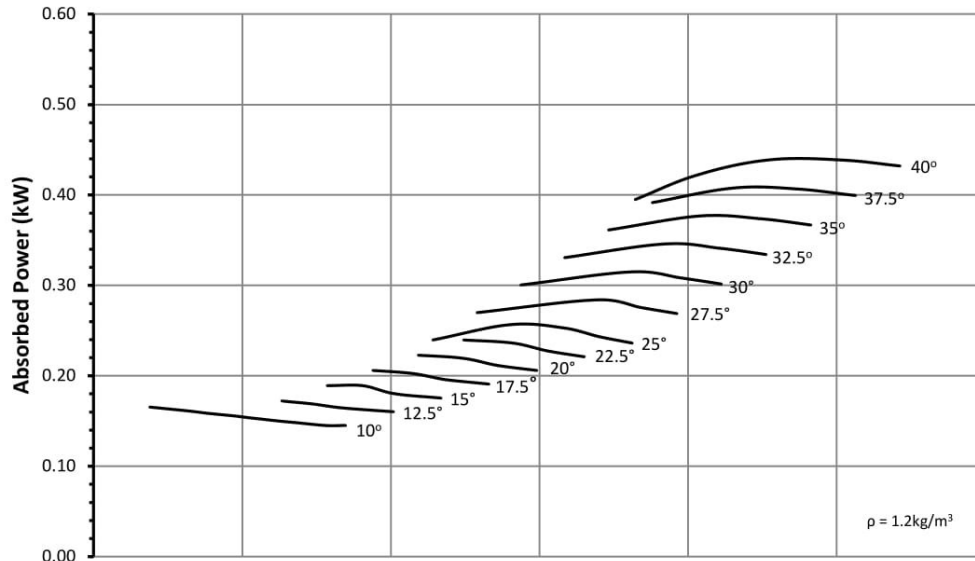

Ref	Full Octave Band Center Frequency								L _{WA} dB(A)
	63	125	250	500	1K	2K	4K	8K	
a	93	91	89	78	74	71	67	62	84
b	93	92	91	76	72	70	67	62	84
c	93	92	90	75	71	70	66	62	84
d	93	92	90	75	72	70	67	62	84
e	89	88	86	75	72	72	69	64	81
f	89	89	89	75	73	72	69	64	83
g	94	96	100	77	73	70	67	62	92
h	92	94	96	76	72	70	67	62	88
j	92	90	87	76	75	73	70	64	83
k	92	90	88	76	75	73	70	65	83
m	93	91	88	76	74	73	70	64	83
n	97	97	97	77	74	73	69	64	90



Performance certified is for Installation type D: Ducted Inlet-Ducted Outlet. Performance ratings do not include the effects of appurtenances (accessories). Power rating kW is fan input power. The Sound Power Level ratings shown are in decibels, referred to 10⁻¹² watts, calculated per AMCA International Standard 301. Values shown are for inlet L_{WA} and L_{WA} sound power levels for Installation type D: Ducted Inlet-Ducted Outlet. Ratings include the effects of duct end correction. The A-weighted sound ratings shown have been calculated per AMCA International Standard 301.

Performance Curve

AAOM 500-160-10B

50Hz 1440 rpm

FEG 50

SAOM 500-160-10B

Outlet Area: 0.200 m²

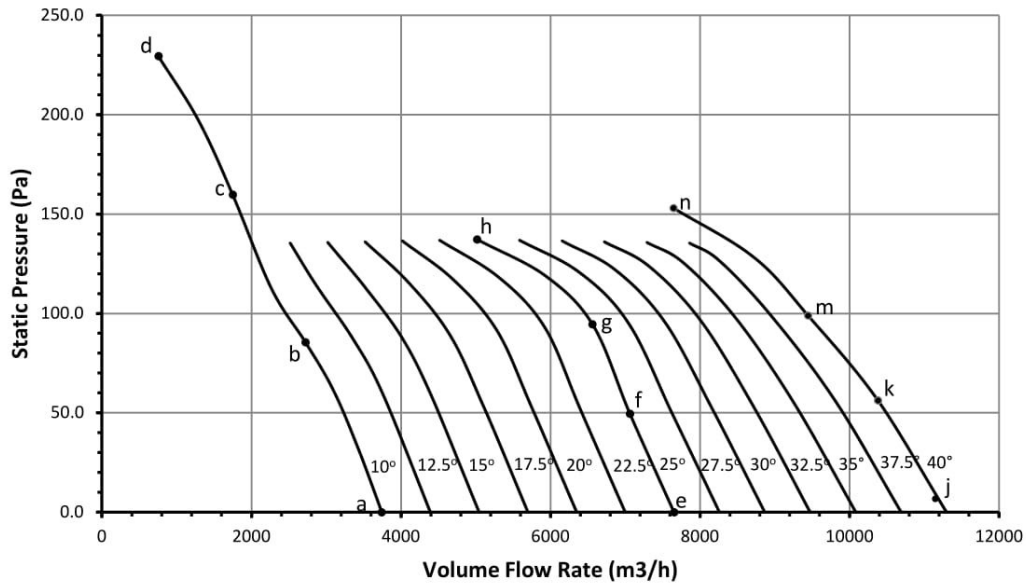
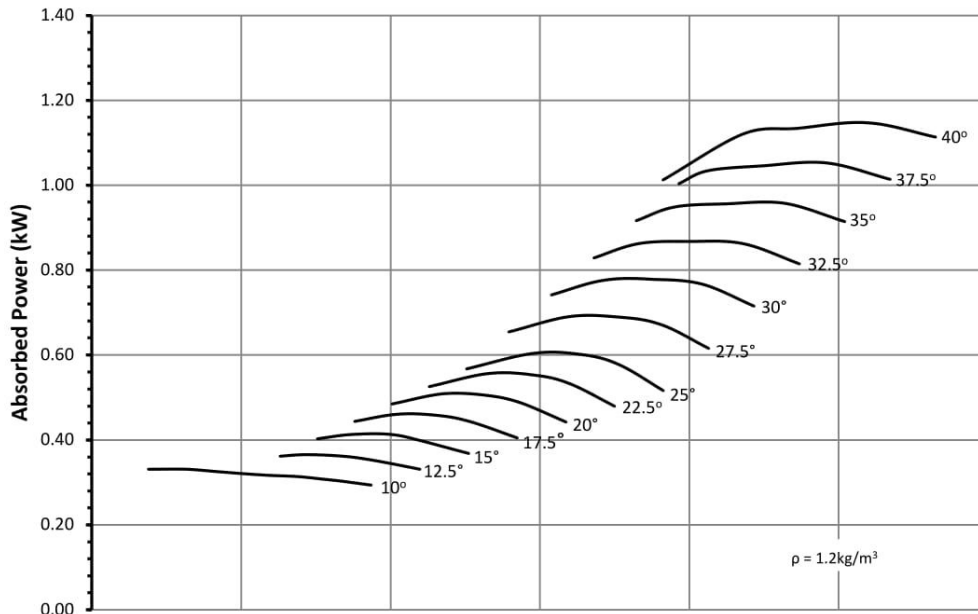

Ref	Full Octave Band Center Frequency								L _W /A dB(A)
	63	125	250	500	1K	2K	4K	8K	
a	86	86	86	80	78	76	72	66	84
b	87	90	95	82	78	75	70	64	88
c	87	88	91	77	74	73	69	63	84
d	86	87	89	77	74	73	70	65	83
e	88	87	86	78	76	76	74	68	84
f	87	86	85	78	76	76	74	69	83
g	87	87	87	81	77	77	74	69	85
h	91	93	96	85	81	77	73	67	90
j	90	89	87	81	78	78	75	70	85
k	90	88	87	81	78	77	75	70	85
m	89	88	87	80	78	77	75	70	85
n	91	89	87	80	78	78	75	70	85



Performance certified is for installation type D: Ducted Inlet-Ducted Outlet. Performance ratings do not include the effects of appurtenances (accessories)
 Power rating kW is fan input power.
 The Sound Power Level ratings shown are in decibels, referred to 10⁻¹² watts, calculated per AMCA International Standard 301. Values shown are for inlet L_Wi and L_W/A sound power levels for Installation type D: Ducted Inlet-Ducted Outlet. Ratings include the effects of duct end correction. The A-weighted sound ratings shown have been calculated per AMCA International Standard 301.

Performance Curve

AAOM 630-160-10B

50Hz 1440 rpm

FEG 60

SAOM 630-160-10B

Outlet Area: 0.317 m²

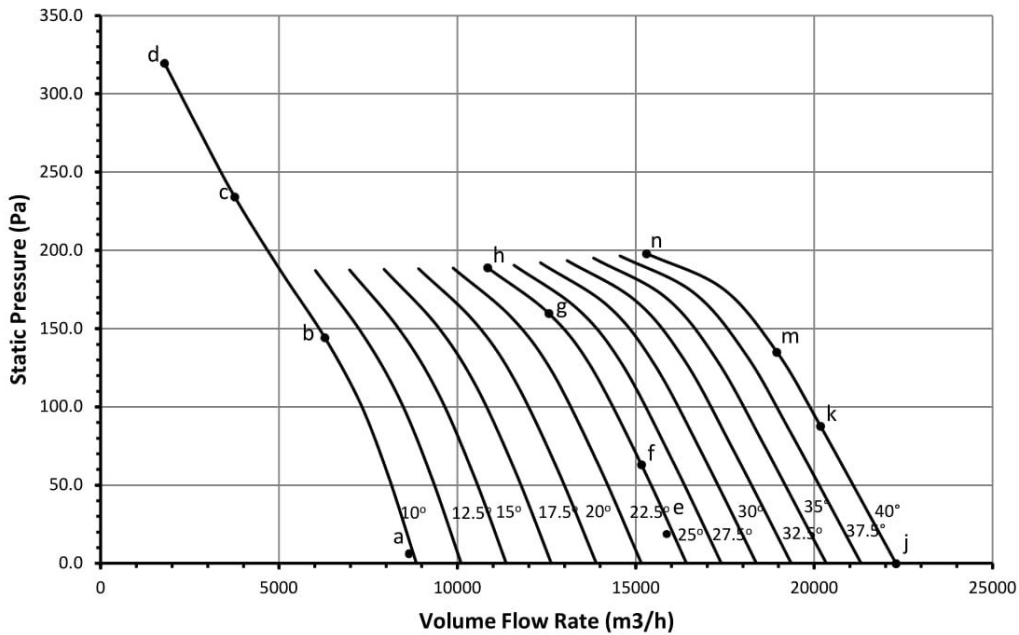
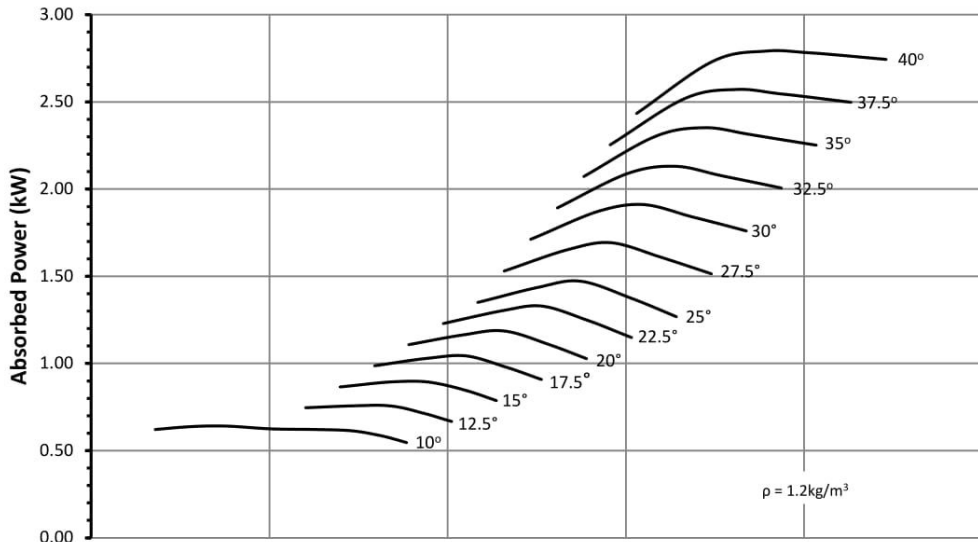

Ref	Full Octave Band Center Frequency								L _{WA}
	63	125	250	500	1K	2K	4K	8K	
a	90	89	88	83	82	81	78	73	88
b	91	91	93	88	86	81	77	71	91
c	89	92	96	81	79	78	75	68	89
d	91	91	91	83	81	79	77	71	88
e	95	93	91	85	82	81	79	75	89
f	93	92	91	84	82	81	79	75	89
g	93	93	93	90	87	84	80	75	92
h	94	94	95	94	88	85	80	74	95
j	99	97	94	88	85	82	80	76	92
k	98	96	94	87	84	82	80	76	91
m	97	96	94	88	85	83	81	76	92
n	103	99	92	84	81	77	72	65	89



Performance certified is for Installation type D: Ducted Inlet-Ducted Outlet. Performance ratings do not include the effects of appurtenances (accessories). Power rating kW is fan input power. The Sound Power Level ratings shown are in decibels, referred to 10⁻¹² watts, calculated per AMCA International Standard 301. Values shown are for inlet L_{WA} and L_{WA} sound power levels for Installation type D: Ducted Inlet-Ducted Outlet. Ratings include the effects of duct end correction. The A-weighted sound ratings shown have been calculated per AMCA International Standard 301.

Performance Curve

AAOM 710-230-12B

50Hz 1440 rpm

SAOM 710-230-12B

Outlet Area: 0.396 m²

FEG 63

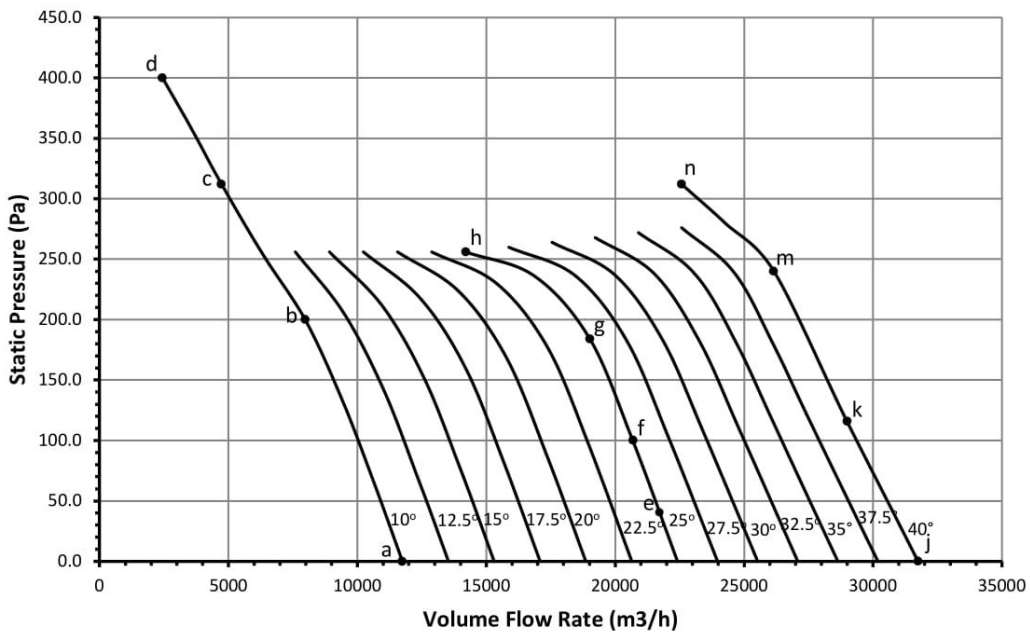
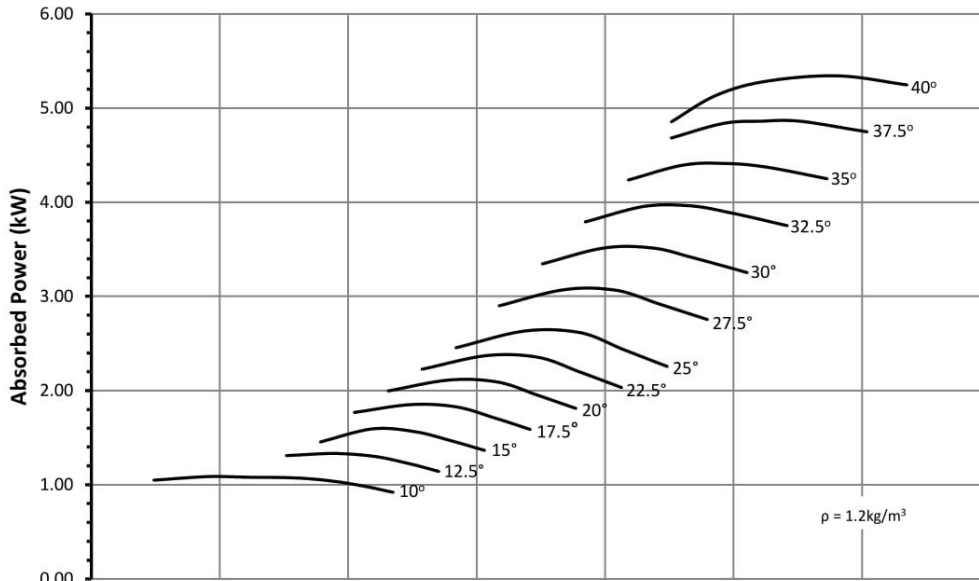

Ref	Full Octave Band Center Frequency								L _W A dB(A)
	63	125	250	500	1K	2K	4K	8K	
a	97	97	94	87	87	86	84	77	93
b	95	95	99	91	89	85	82	75	95
c	94	94	97	85	84	83	80	74	92
d	95	95	94	85	84	83	81	76	91
e	104	104	98	90	88	86	85	80	96
f	102	102	97	91	88	87	85	80	95
g	100	100	98	94	90	88	85	79	97
h	104	104	105	94	91	87	83	77	99
j	103	103	95	91	87	87	86	82	95
k	102	102	94	88	86	86	85	82	94
m	103	103	96	88	86	86	86	82	94
n	106	106	100	92	89	88	86	82	97



Performance certified is for Installation type D: Ducted Inlet-Ducted Outlet. Performance ratings do not include the effects of appurtenances (accessories). Power rating kW is fan input power. The Sound Power Level ratings shown are in decibels, referred to 10⁻¹² watts, calculated per AMCA International Standard 301. Values shown are for inlet L_W and L_WA sound power levels for Installation type D: Ducted Inlet-Ducted Outlet. Ratings include the effects of duct end correction. The A-weighted sound ratings shown have been calculated per AMCA International Standard 301.

Performance Curve

FEG 50

AAOM 800-400-08C

SAOM 800-400-08C

50Hz 1440 rpm

Outlet Area: 0.509 m²

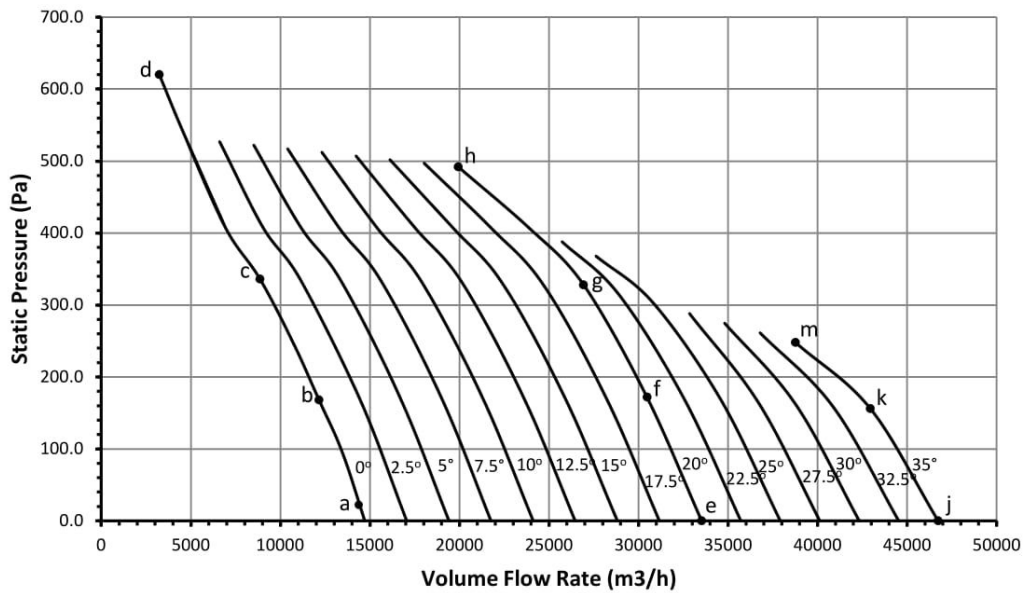
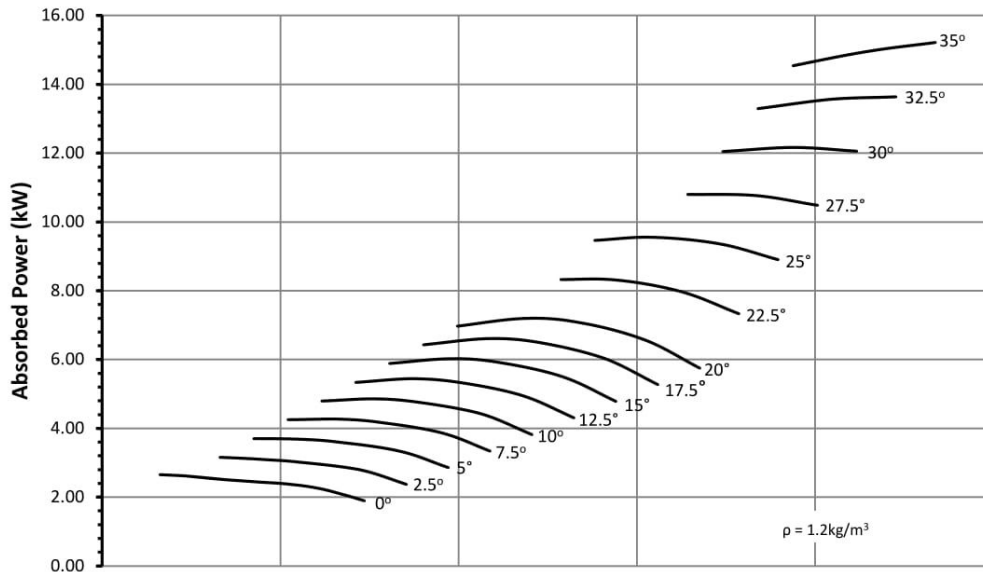

Ref	Full Octave Band Center Frequency								L _W A dB(A)
	63	125	250	500	1K	2K	4K	8K	
a	100	100	100	94	89	87	83	74	97
b	100	100	99	96	92	90	83	74	98
c	106	106	102	95	90	86	79	73	98
d	110	110	100	93	89	87	83	77	98
e	107	107	106	95	91	87	83	75	100
f	107	107	105	93	89	86	82	74	99
g	107	107	106	92	88	86	83	75	99
h	108	108	104	94	90	88	84	78	99
j	112	112	111	99	96	93	88	83	105
k	110	110	112	98	95	92	88	82	105
m	108	108	109	96	94	92	88	83	103



Performance certified is for Installation type D: Ducted Inlet-Ducted Outlet. Performance ratings do not include the effects of appurtenances (accessories)
 Power rating kW is fan input power.
 The Sound Power Level ratings shown are in decibels, referred to 10⁻¹² watts, calculated per AMCA International Standard 301. Values shown are for inlet L_Wi and L_WA sound power levels for Installation type D: Ducted Inlet-Ducted Outlet. Ratings include the effects of duct end correction.
 The A-weighted sound ratings shown have been calculated per AMCA International Standard 301.

Performance Curve

AAOM 900-400-08C

50Hz 1440 rpm

FEG 53

SAOM 900-400-08C

Outlet Area: 0.643 m²

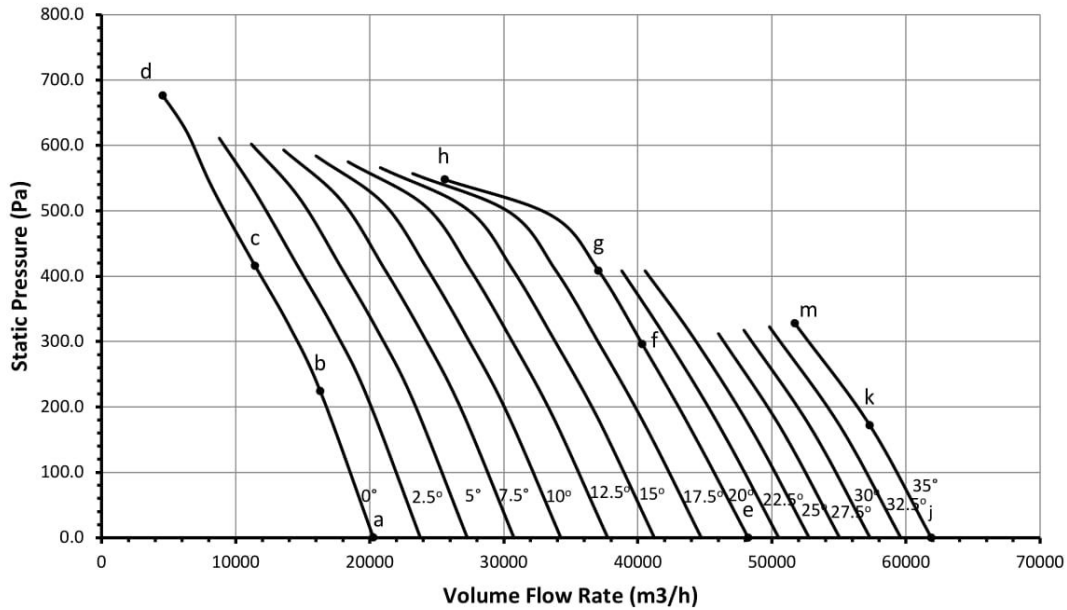
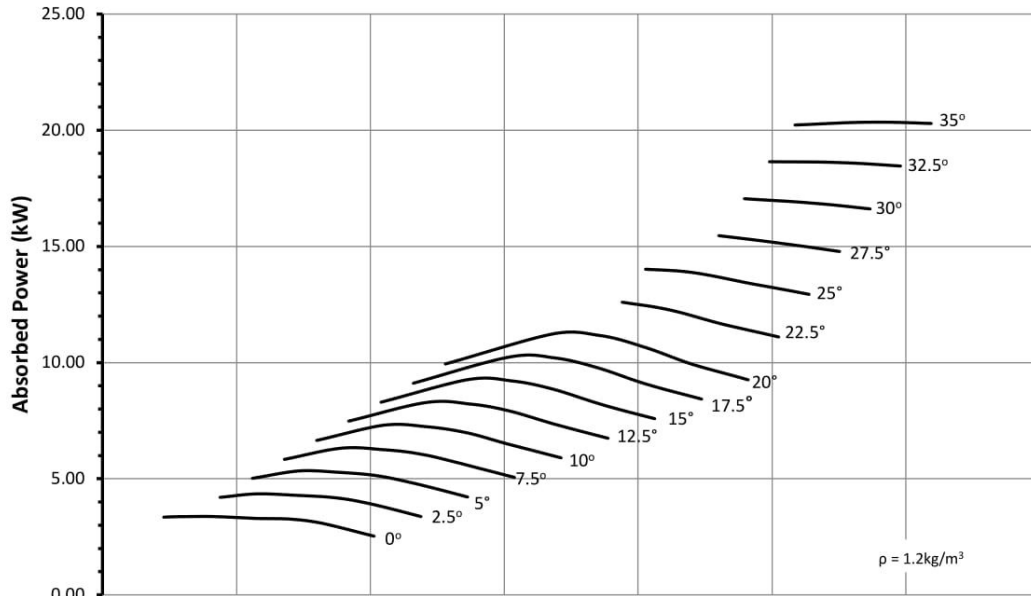

Ref	Full Octave Band Center Frequency								L _{W/A} dB(A)
	63	125	250	500	1K	2K	4K	8K	
a	98	98	95	96	95	93	89	80	100
b	98	98	94	97	97	94	87	79	101
c	106	106	99	99	94	90	84	77	100
d	110	110	100	94	90	88	86	80	99
e	104	104	102	98	93	90	89	81	100
f	104	104	101	96	90	88	87	81	98
g	104	104	101	96	91	88	88	82	99
h	105	105	100	97	92	90	89	83	99
j	108	108	105	102	97	93	91	86	103
k	107	107	104	101	96	93	91	86	103
m	106	106	103	100	95	92	91	86	102



Performance certified is for installation type D: Ducted Inlet-Ducted Outlet. Performance ratings do not include the effects of appurtenances (accessories). Power rating kW is fan input power. The Sound Power Level ratings shown are in decibels, referred to 10⁻¹² watts, calculated per AMCA International Standard 301. Values shown are for inlet L_{W/A} and L_{W/A} sound power levels for Installation type D: Ducted Inlet-Ducted Outlet. Ratings include the effects of duct end correction. The A-weighted sound ratings shown have been calculated per AMCA International Standard 301.

Performance Curve

AAOM 1000-400-08C

50Hz 1440 rpm

FEG 60

SAOM 1000-400-08C

Outlet Area: 0.793 m²

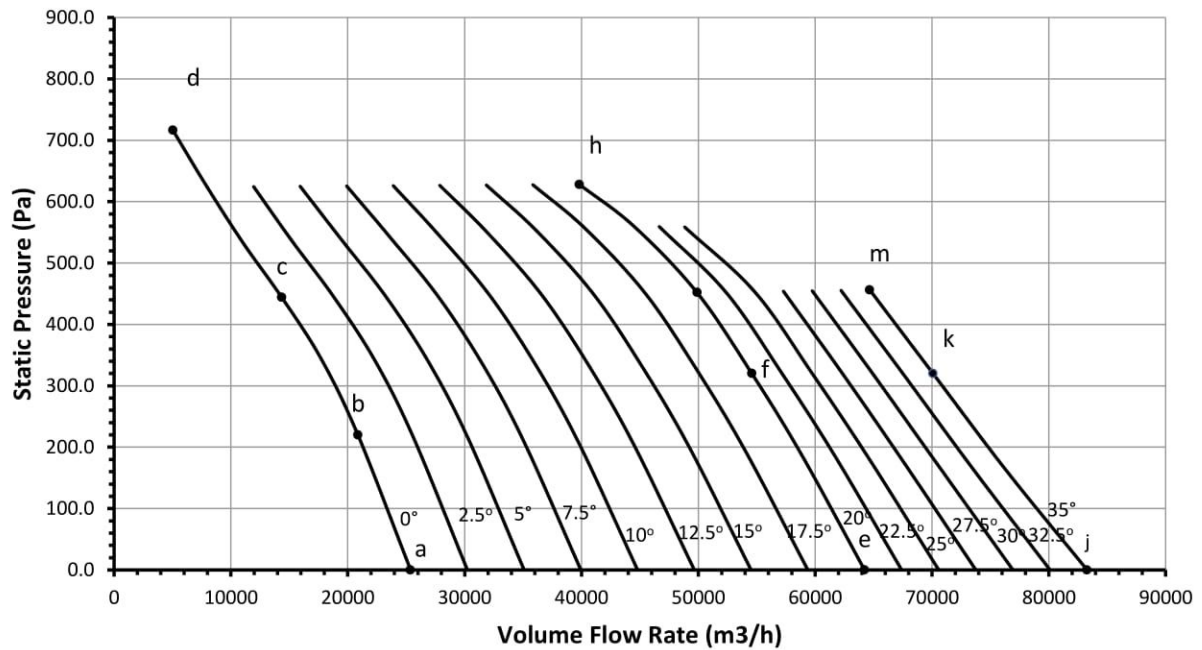
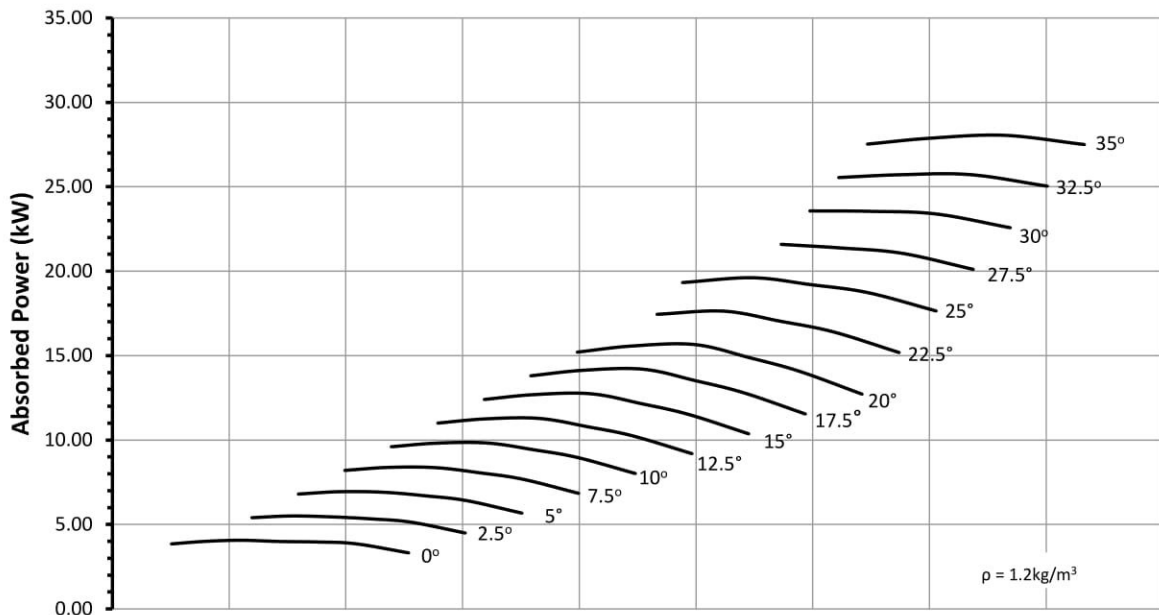

Ref	Full Octave Band Center Frequency								L _{WA} dB(A)
	63	125	250	500	1K	2K	4K	8K	
a	100	100	98	99	99	97	92	84	103
b	100	100	99	103	99	94	89	81	104
c	112	112	101	99	95	92	88	79	102
d	107	108	100	97	93	92	90	83	100
e	105	105	106	102	97	93	92	86	104
f	103	103	105	101	94	92	90	85	102
g	104	104	104	100	94	92	91	86	102
h	105	105	109	106	100	97	93	87	107
j	107	107	110	105	100	96	94	89	107
k	106	106	107	103	99	97	94	89	106
m	106	106	109	103	99	97	94	89	106



Performance certified is for Installation type D: Ducted Inlet-Ducted Outlet. Performance ratings do not include the effects of appurtenances (accessories). Power rating kW is fan input power. The Sound Power Level ratings shown are in decibels, referred to 10⁻¹² watts, calculated per AMCA International Standard 301. Values shown are for inlet L_{WA} and L_{WA} sound power levels for Installation type D: Ducted Inlet-Ducted Outlet. Ratings include the effects of duct end correction. The A-weighted sound ratings shown have been calculated per AMCA International Standard 301.

Performance Curve

AAOM 1120-400-12C

50Hz 1440 rpm

FEG 56

SAOM 1120-400-12C

Outlet Area: 0.994 m²

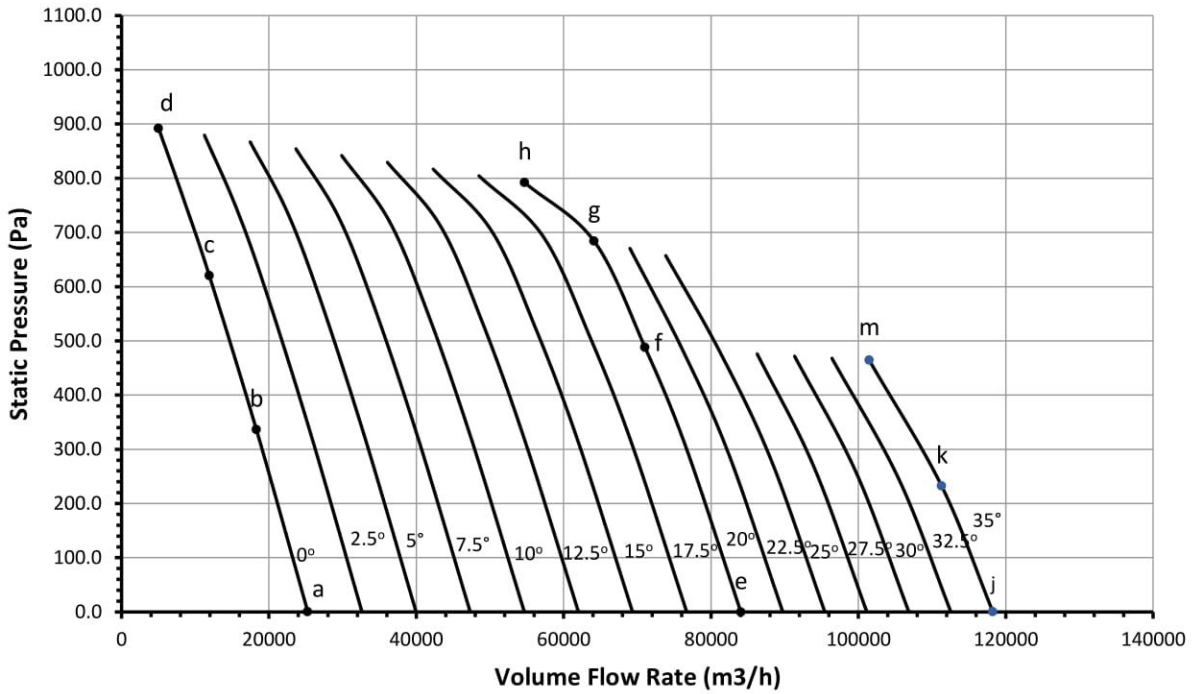
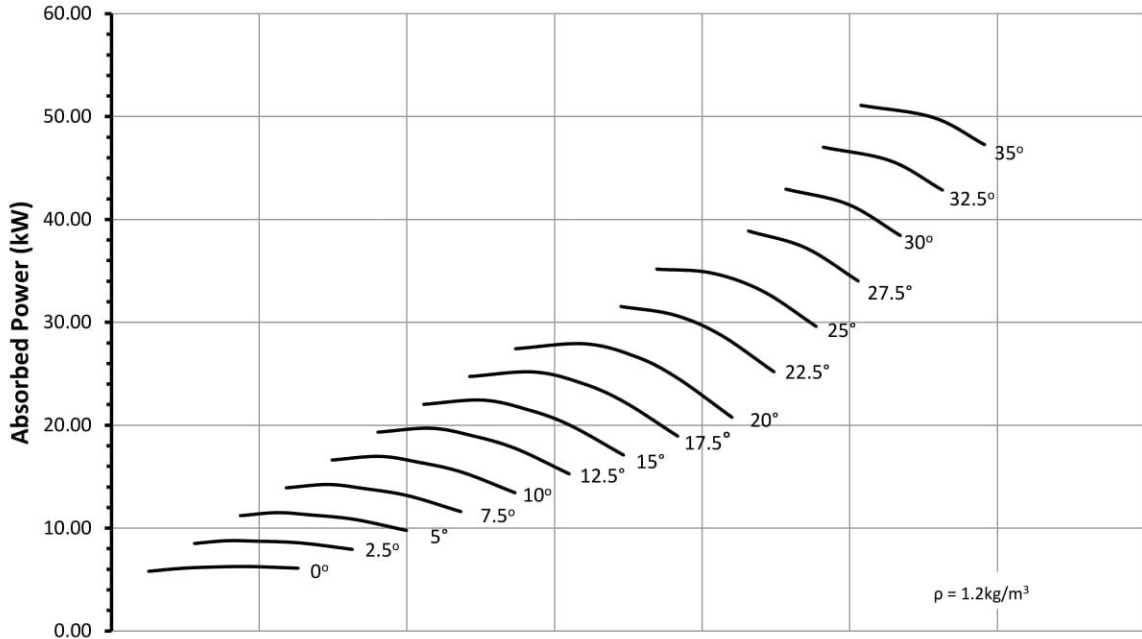

Ref	Full Octave Band Center Frequency								L _W /A dB(A)
	63	125	250	500	1K	2K	4K	8K	
a	106	106	109	106	102	99	96	89	108
b	107	107	107	102	100	97	94	85	105
c	106	106	103	99	98	96	93	85	103
d	107	107	106	100	98	96	93	87	104
e	110	110	110	104	101	98	97	92	108
f	111	111	111	102	99	98	95	91	107
g	111	111	111	107	103	101	97	92	110
h	114	114	115	110	106	102	97	90	112
j	115	115	113	107	103	100	96	92	110
k	114	114	114	106	103	100	96	93	110
m	115	115	111	106	103	100	97	93	109



Performance certified is for Installation type D: Ducted Inlet-Ducted Outlet. Performance ratings do not include the effects of appurtenances (accessories). Power rating kW is fan input power. The Sound Power Level ratings shown are in decibels, referred to 10⁻¹² watts, calculated per AMCA International Standard 301. Values shown are for inlet L_W and L_W/A sound power levels for Installation type D: Ducted Inlet-Ducted Outlet. Ratings include the effects of duct end correction. The A-weighted sound ratings shown have been calculated per AMCA International Standard 301.

Performance Curve

AAOM 1250-400-12C

50Hz 1440 rpm

FEG 63

SAOM 1250-400-12C

Outlet Area: 1.237 m²

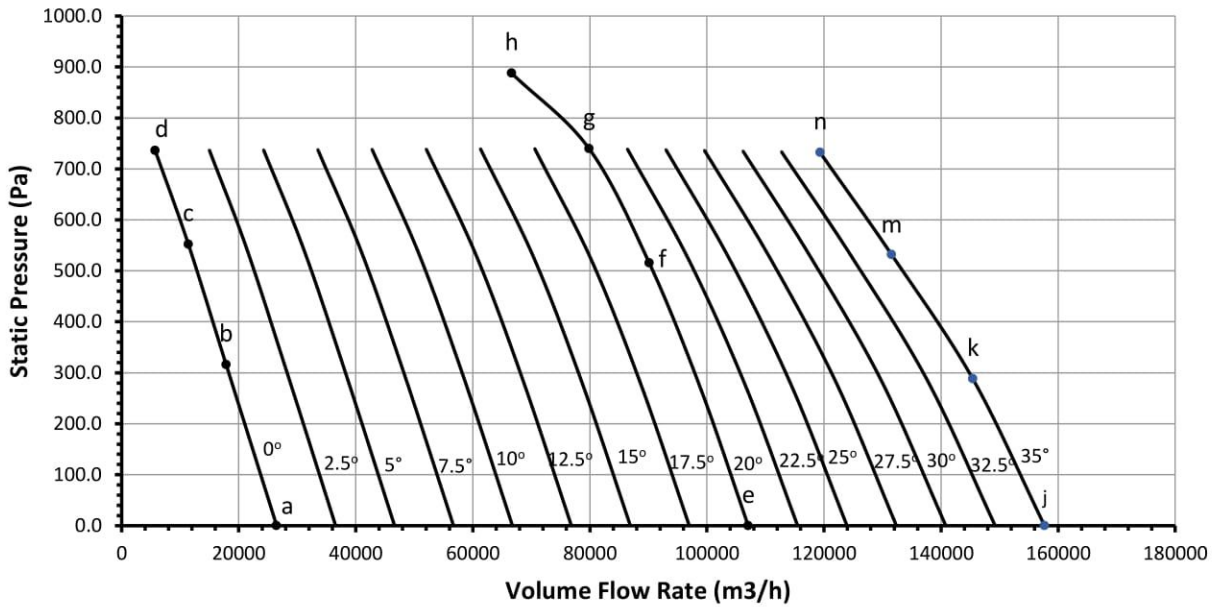
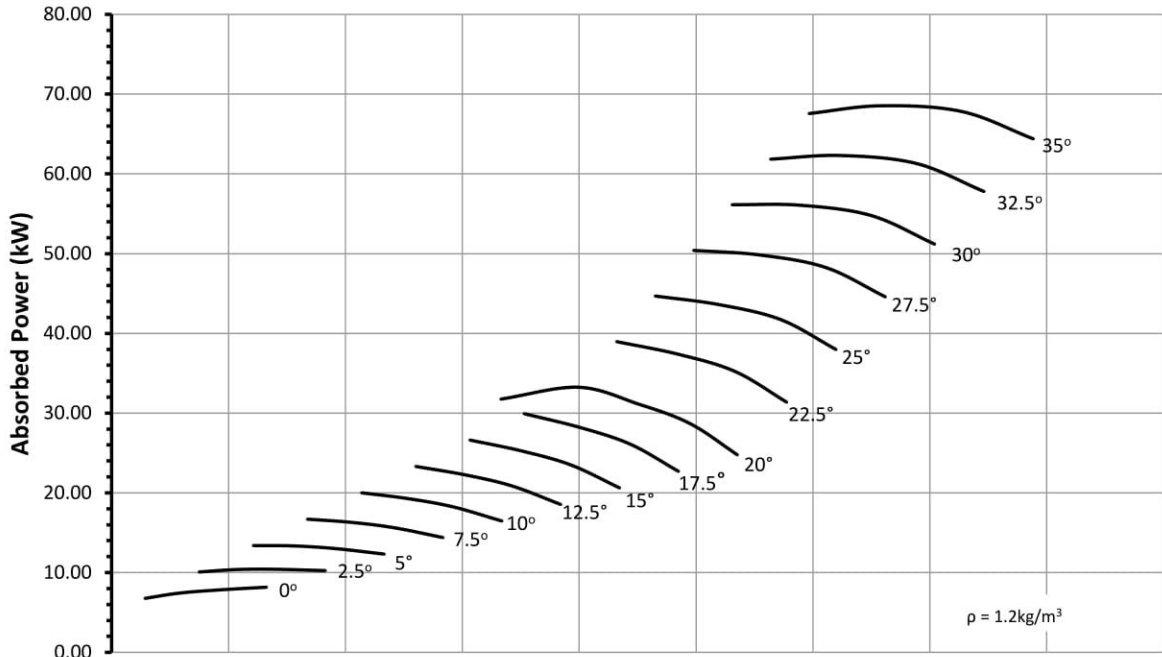

Ref	Full Octave Band Center Frequency								L _W /A
	63	125	250	500	1K	2K	4K	8K	
a	110	110	109	107	104	102	98	92	110
b	107	108	103	101	103	101	97	89	107
c	108	108	102	101	102	100	97	90	107
d	108	109	102	101	101	100	97	91	106
e	111	111	107	110	104	102	101	97	111
f	110	110	107	110	107	106	102	96	113
g	111	111	115	114	110	106	101	94	115
h	119	119	119	113	108	105	99	92	115
j	118	118	111	112	106	103	100	96	113
k	117	117	109	111	107	104	101	96	113
m	116	116	110	111	108	106	102	97	113
n	119	119	118	113	111	108	103	97	116



Performance certified is for Installation type D: Ducted Inlet-Ducted Outlet. Performance ratings do not include the effects of appurtenances (accessories). Power rating kW is fan input power. The Sound Power Level ratings shown are in decibels, referred to 10⁻¹² watts, calculated per AMCA International Standard 301. Values shown are for inlet L_WI and L_W/A sound power levels for Installation type D: Ducted Inlet-Ducted Outlet. Ratings include the effects of duct end correction. The A-weighted sound ratings shown have been calculated per AMCA International Standard 301.

Performance Curve

AAOM 400-160-10B
SAOM 400-160-10B

50Hz 960 rpm

Outlet Area: 0.127 m²

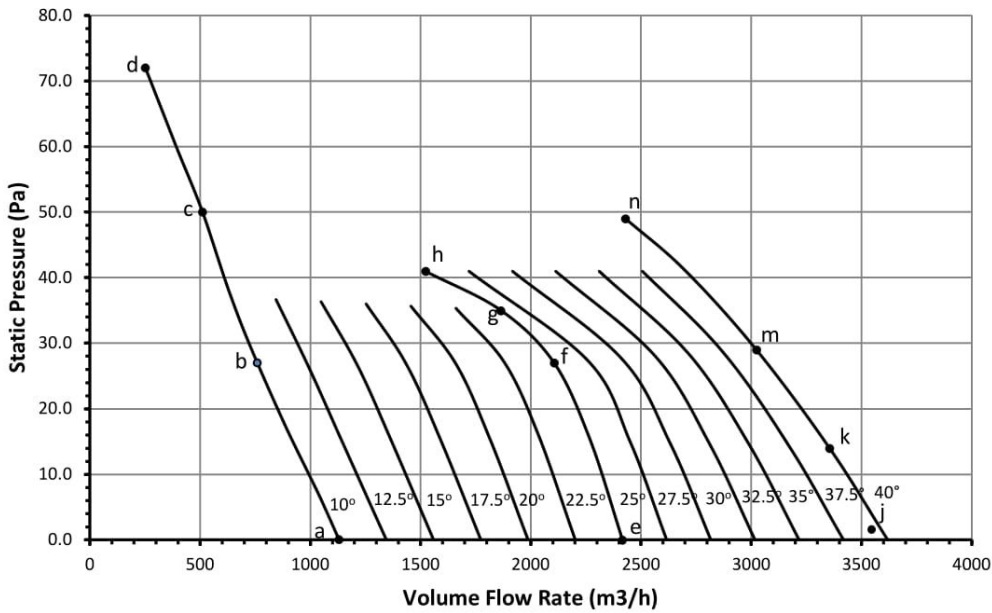
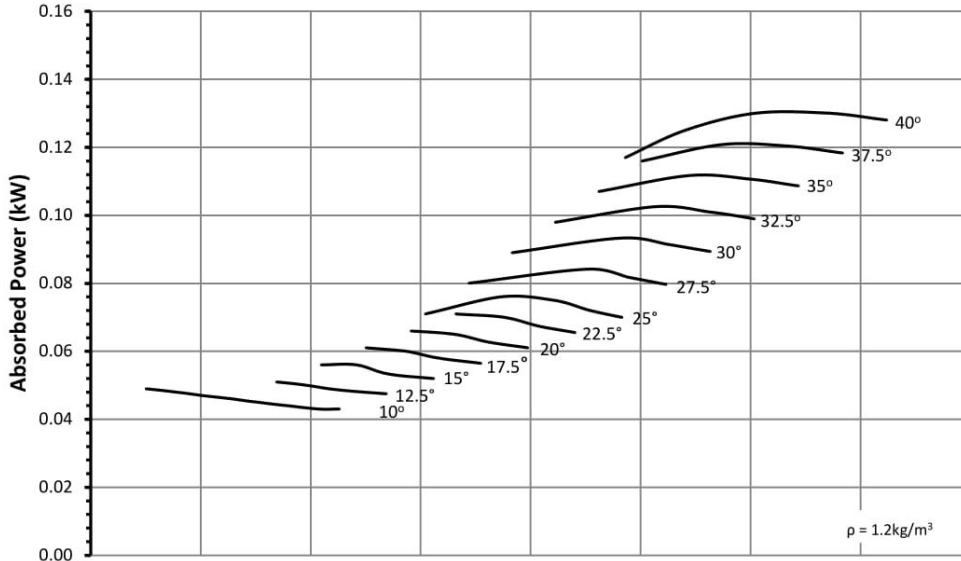

Ref	Full Octave Band Center Frequency								L _{WA} dB(A)
	63	125	250	500	1K	2K	4K	8K	
a	84	81	71	66	63	61	55	50	70
b	84	82	70	64	62	60	55	51	70
c	84	81	68	63	62	60	55	50	69
d	84	81	69	64	63	60	56	51	70
e	80	77	68	64	64	63	57	52	70
f	80	80	67	64	64	63	57	52	70
g	85	91	71	65	62	61	56	51	76
h	83	87	69	64	62	61	56	51	73
j	84	78	68	68	65	63	58	52	71
k	84	79	67	67	65	63	58	52	71
m	84	79	67	66	65	63	58	52	71
n	89	89	71	66	65	63	58	52	75



Performance certified is for Installation type D: Ducted Inlet-Ducted Outlet. Performance ratings do not include the effects of appurtenances (accessories)
 Power rating kW is fan input power.
 The Sound Power Level ratings shown are in decibels, referred to 10⁻¹² watts, calculated per AMCA International Standard 301. Values shown are for inlet L_{WA} and L_{WA}A sound power levels for Installation type D: Ducted Inlet-Ducted Outlet. Ratings include the effects of duct end correction.
 The A-weighted sound ratings shown have been calculated per AMCA International Standard 301.

Performance Curve

AAOM 500-160-10B

50Hz 960 rpm

FEG 50

SAOM 500-160-10B

Outlet Area: 0.200 m²

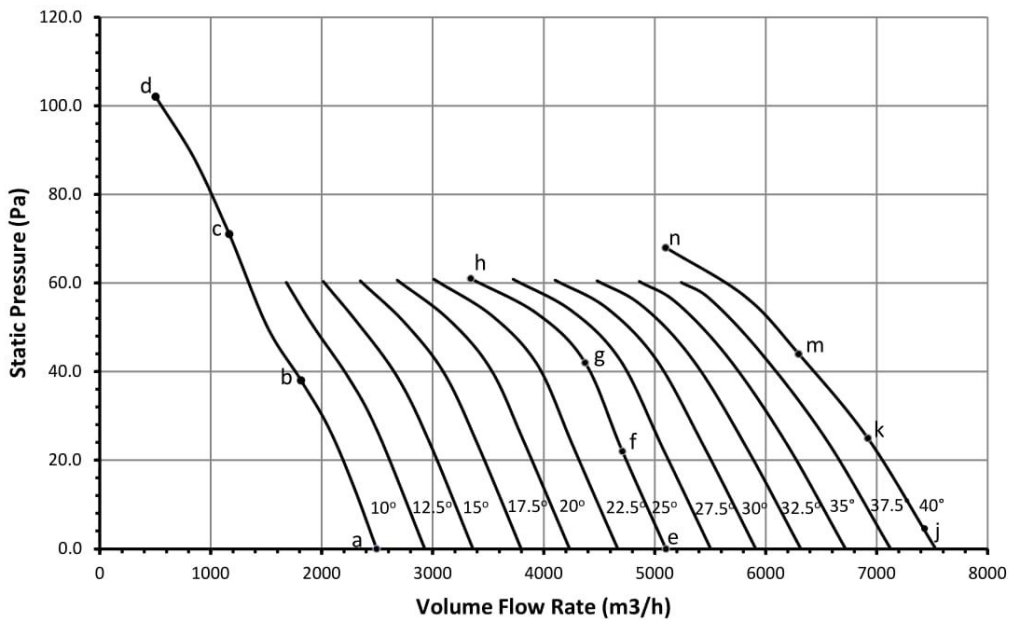
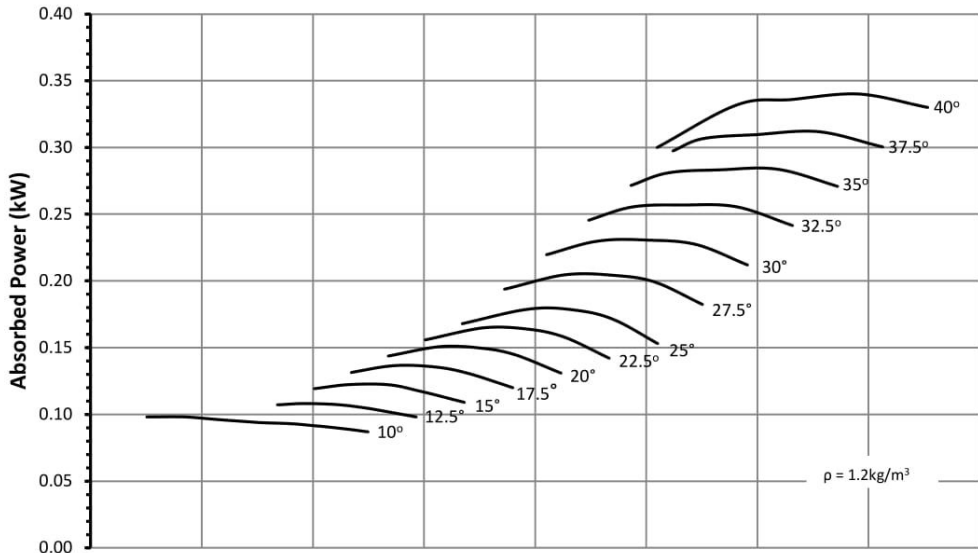

Ref	Full Octave Band Center Frequency							L _w A dB(A)	
	63	125	250	500	1K	2K	4K		8K
a	77	78	73	69	68	66	59	54	73
b	79	86	74	71	67	64	58	52	75
c	78	82	70	65	65	63	57	51	71
d	77	80	70	66	65	64	59	52	71
e	79	77	71	67	68	67	62	56	73
f	78	76	70	67	68	66	62	56	73
g	79	78	75	69	69	67	63	56	74
h	82	87	79	73	70	67	61	54	77
j	81	78	74	70	69	68	64	57	75
k	81	78	74	69	69	68	64	57	74
m	81	78	73	69	69	68	64	57	74
n	82	79	73	69	70	68	64	57	75



Performance certified for Installation type D: Ducted Inlet-Ducted Outlet. Performance ratings do not include the effects of appurtenances (accessories). Power rating kW is fan input power. The Sound Power Level ratings shown are in decibels, referred to 10⁻¹² watts, calculated per AMCA International Standard 301. Values shown are for inlet L_w and L_wA sound power levels for Installation type D: Ducted Inlet-Ducted Outlet. Ratings include the effects of duct end correction. The A-weighted sound ratings shown have been calculated per AMCA International Standard 301.

Performance Curve

AAOM 630-160-10B

50Hz 960 rpm

FEG 60

SAOM 630-160-10B

Outlet Area: 0.317 m²

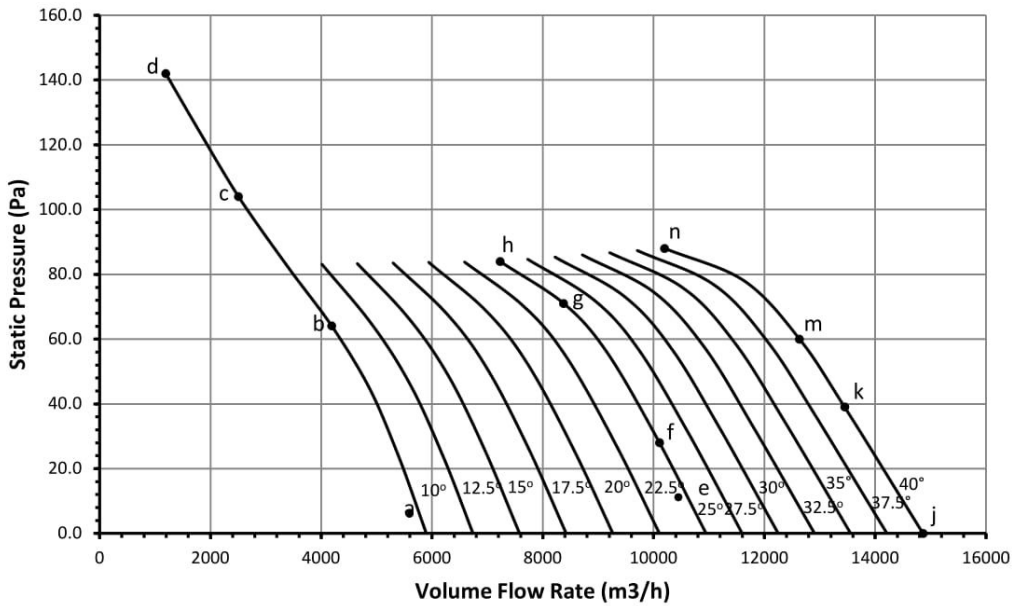
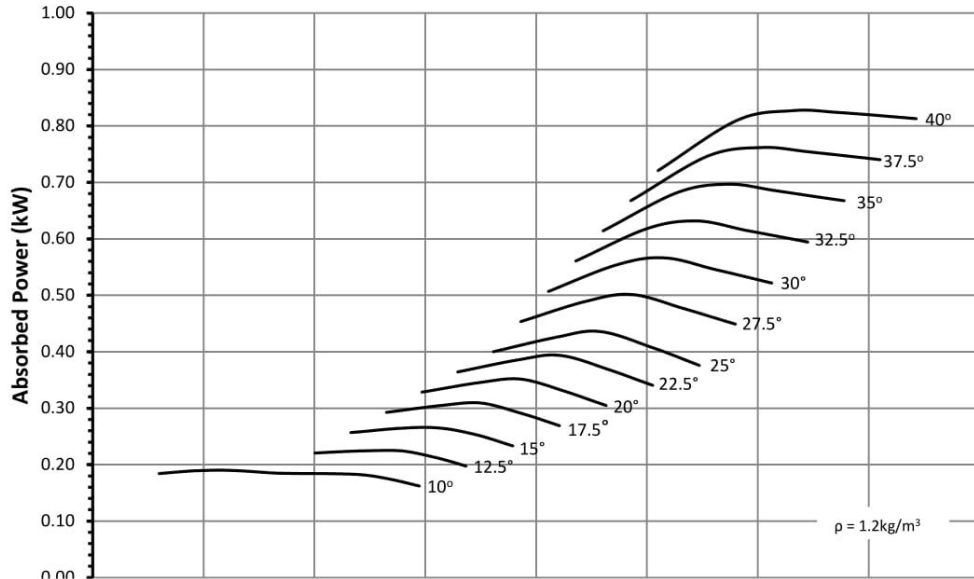

Ref	Full Octave Band Center Frequency								L _{WA} dB(A)
	63	125	250	500	1K	2K	4K	8K	
a	81	79	75	74	72	72	66	61	78
b	82	84	79	79	74	71	65	58	80
c	81	87	73	71	69	68	63	56	76
d	82	82	74	74	71	70	65	59	77
e	86	83	77	74	73	72	69	62	79
f	84	82	77	74	73	72	69	63	79
g	85	84	83	79	77	74	69	63	82
h	85	86	88	81	78	74	68	61	84
j	91	85	81	77	74	73	70	64	81
k	89	85	80	76	74	73	70	64	80
m	88	85	81	77	75	74	70	65	81
n	94	84	77	73	70	66	58	53	77



Performance certified is for Installation type D: Ducted Inlet-Ducted Outlet. Performance ratings do not include the effects of appurtenances (accessories). Power rating kW is fan input power. The Sound Power Level ratings shown are in decibels, referred to 10⁻¹² watts, calculated per AMCA International Standard 301. Values shown are for inlet L_{WA} and L_{WA} sound power levels for Installation type D: Ducted Inlet-Ducted Outlet. Ratings include the effects of duct end correction. The A-weighted sound ratings shown have been calculated per AMCA International Standard 301.

Performance Curve

AAOM 710-230-12B

50Hz 960 rpm

FEG 63

SAOM 710-230-12B

Outlet Area: 0.396 m²

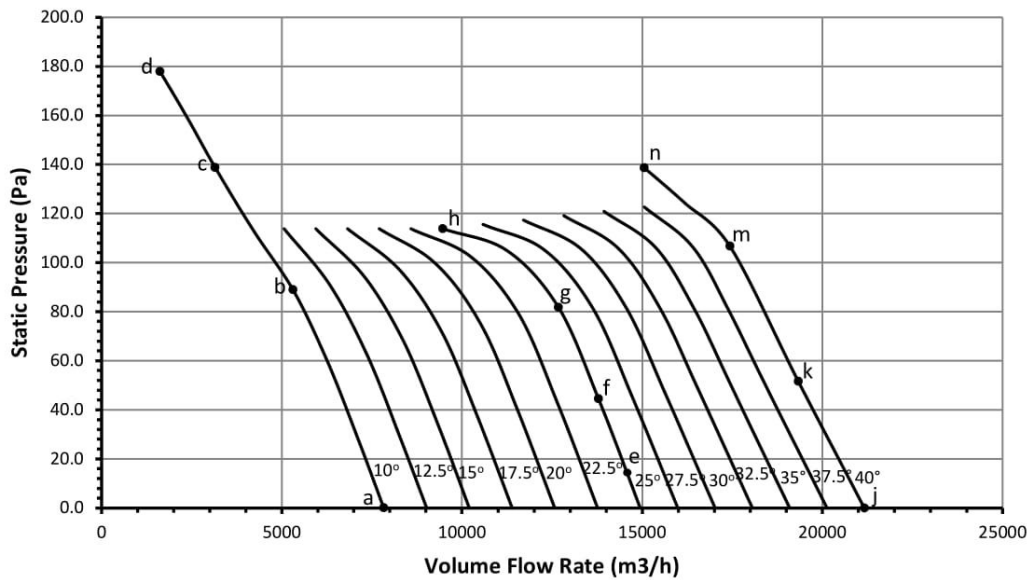
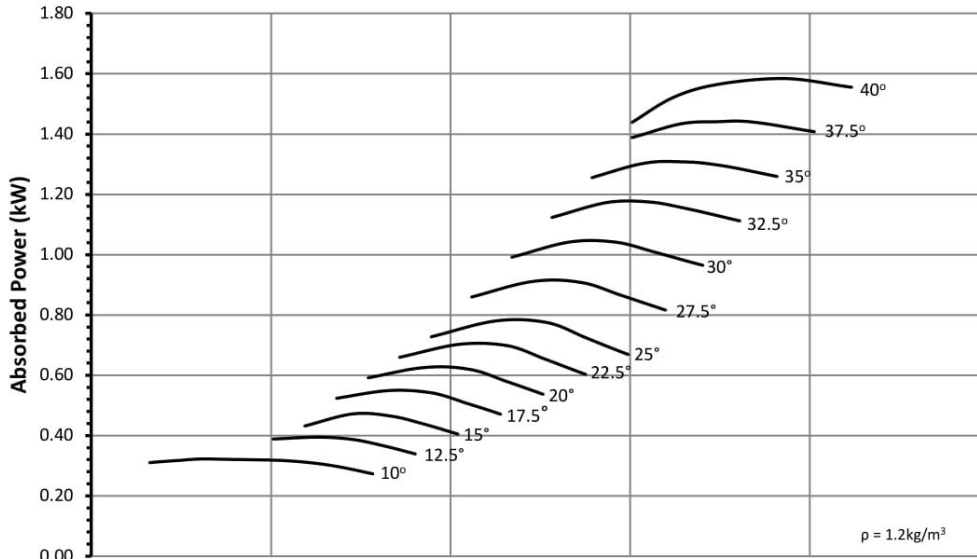

Ref	Full Octave Band Center Frequency								L _W A dB(A)
	63	125	250	500	1K	2K	4K	8K	
a	88	86	85	78	78	76	71	65	83
b	86	89	91	81	78	75	69	62	85
c	85	87	89	75	74	72	68	61	83
d	86	86	85	76	75	73	69	63	81
e	95	91	89	80	78	76	73	67	85
f	93	90	88	81	79	77	73	67	85
g	92	90	89	83	80	77	73	67	86
h	95	96	97	83	80	76	71	64	90
j	94	89	86	80	78	77	75	70	85
k	93	89	86	78	77	77	74	70	84
m	94	90	87	78	77	77	75	70	85
n	97	94	91	81	80	78	75	70	87



Performance certified is for Installation type D: Ducted Inlet-Ducted Outlet. Performance ratings do not include the effects of appurtenances (accessories)
 Power rating kW is fan input power.
 The Sound Power Level ratings shown are in decibels, referred to 10⁻¹² watts, calculated per AMCA International Standard 301. Values shown are for inlet L_W and L_WA sound power levels for Installation type D: Ducted Inlet-Ducted Outlet. Ratings include the effects of duct end correction. The A-weighted sound ratings shown have been calculated per AMCA International Standard 301.

Performance Curve

AAOM 800-400-08C

50Hz 960 rpm

FEG 50

SAOM 800-400-08C

Outlet Area: 0.509 m²

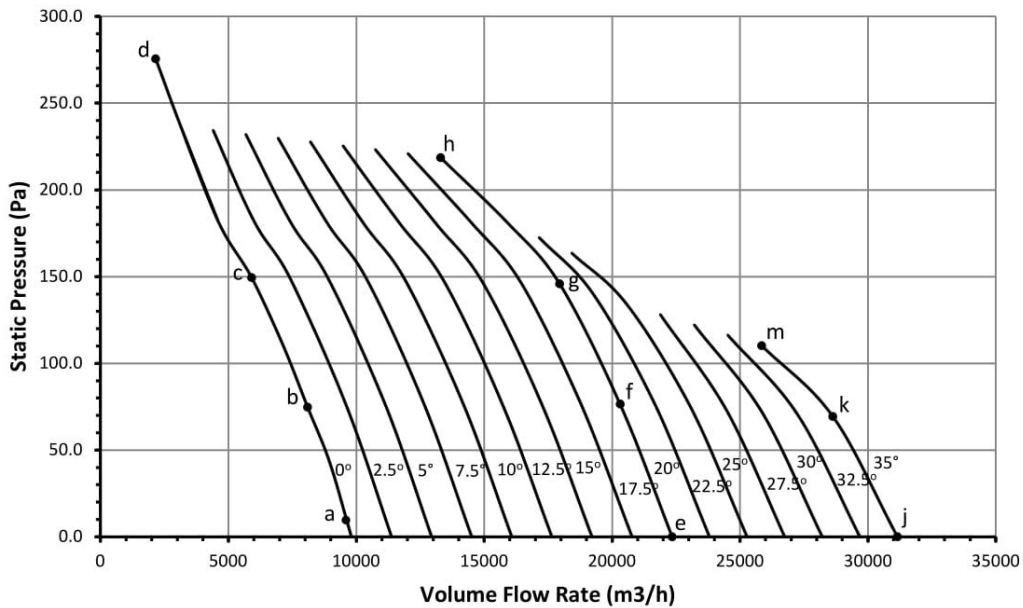
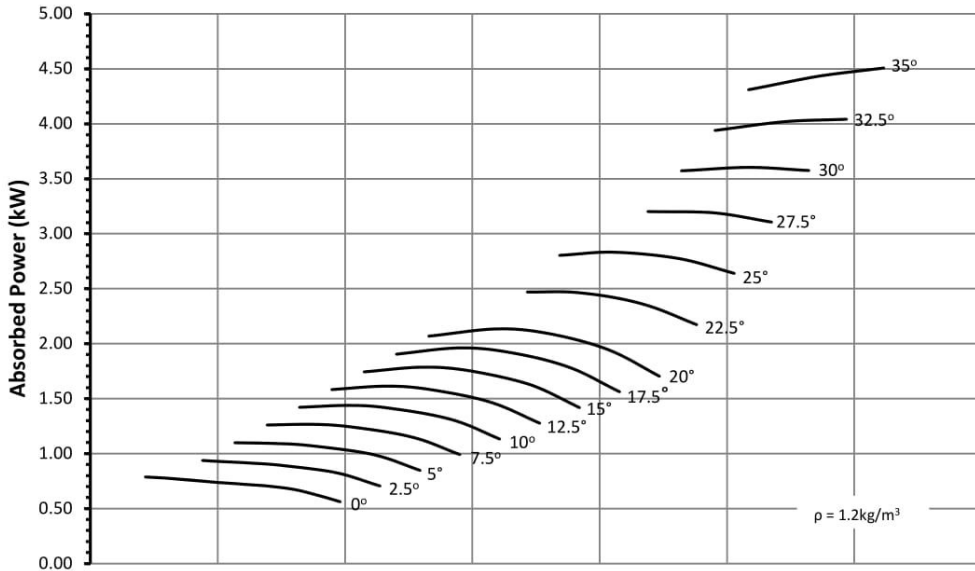

Ref	Full Octave Band Center Frequency								L _{WA}
	63	125	250	500	1K	2K	4K	8K	
a	91	91	88	82	79	76	69	62	85
b	91	90	88	85	82	77	69	62	87
c	98	95	89	83	79	73	67	61	86
d	102	96	87	82	79	76	70	68	86
e	99	98	91	84	80	76	70	65	88
f	98	97	89	82	78	75	69	64	87
g	98	97	89	81	78	75	69	64	86
h	100	97	89	83	80	77	71	67	87
j	103	103	96	89	85	81	76	72	93
k	99	100	93	86	84	81	76	73	92
m	99	100	93	86	84	81	76	73	91



Performance certified is for Installation type D: Ducted Inlet-Ducted Outlet. Performance ratings do not include the effects of appurtenances (accessories). Power rating kW is fan input power. The Sound Power Level ratings shown are in decibels, referred to 10⁻¹² watts, calculated per AMCA International Standard 301. Values shown are for inlet L_{WA} and L_{WA} sound power levels for Installation type D: Ducted Inlet-Ducted Outlet. Ratings include the effects of duct end correction. The A-weighted sound ratings shown have been calculated per AMCA International Standard 301.

Performance Curve

FEG 53

AAOM 900-400-08C

SAOM 900-400-08C

50Hz 960 rpm

Outlet Area: 0.643 m²

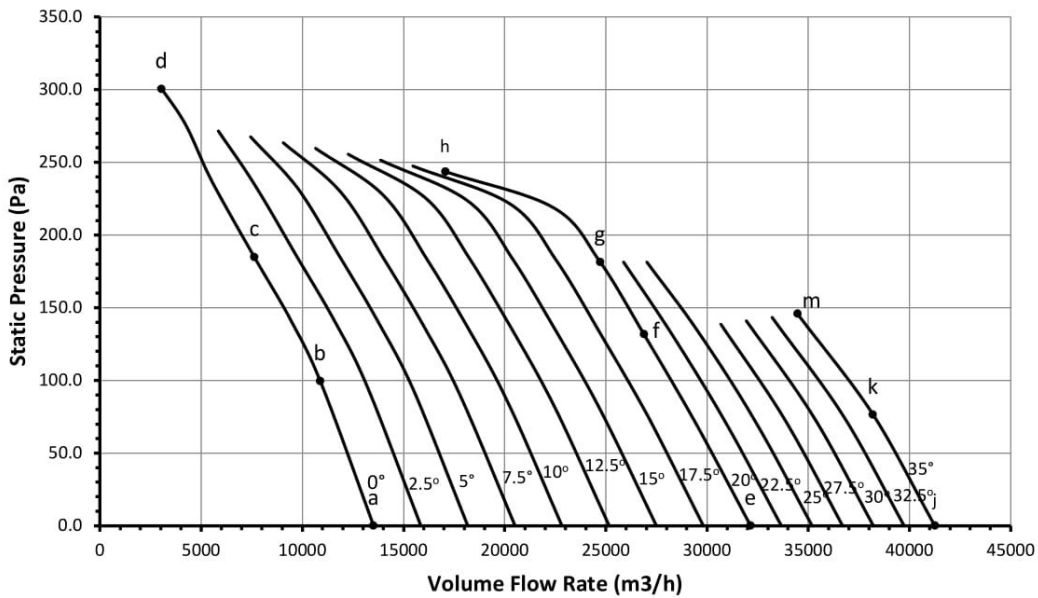
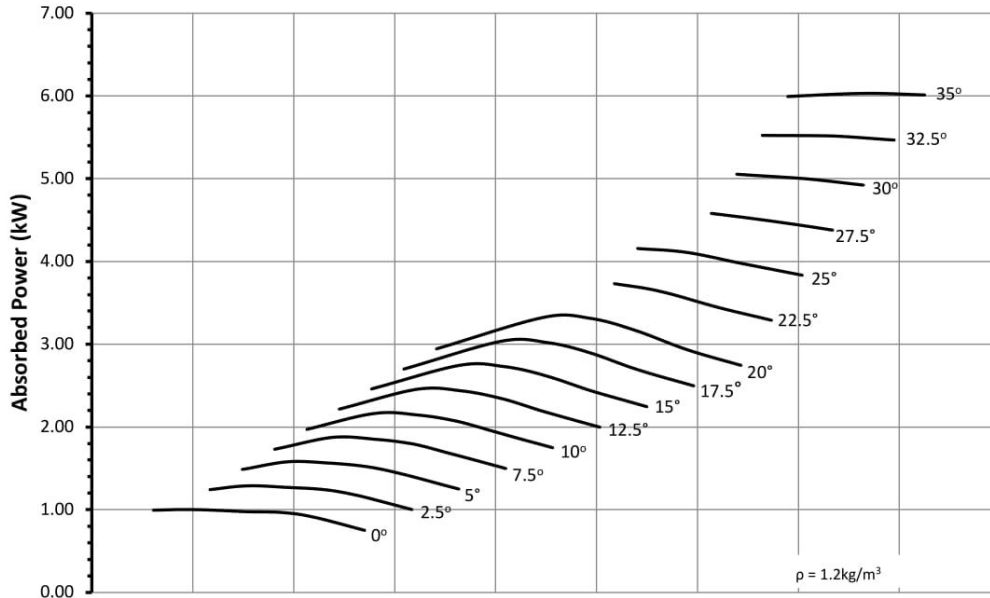

Ref	Full Octave Band Center Frequency								L _{WA} dB(A)
	63	125	250	500	1K	2K	4K	8K	
a	89	88	87	87	85	82	74	67	89
b	89	87	87	88	86	81	73	66	90
c	97	93	91	87	83	78	71	64	89
d	101	95	88	83	80	78	73	68	87
e	95	94	91	86	83	81	76	69	89
f	95	93	89	84	80	79	75	69	87
g	96	94	89	84	81	79	76	70	88
h	96	93	89	85	82	80	77	71	88
j	99	97	94	90	86	83	79	75	92
k	98	96	94	89	85	83	79	75	92
m	97	95	93	89	85	83	79	75	91



Performance certified is for installation type D: Ducted Inlet- Ducted Outlet. Performance ratings do not include the effects of appurtenances (accessories) Power rating kW is fan input power. The Sound Power Level ratings shown are in decibels, referred to 10⁻¹² watts, calculated per AMCA International Standard 301. Values shown are for inlet L_{WA} and L_{WA} sound power levels for Installation type D: Ducted Inlet-Ducted Outlet. Ratings include the effects of duct end correction. The A-weighted sound ratings shown have been calculated per AMCA International Standard 301.

Performance Curve

FEG 60

AAOM 1000-400-08C 50Hz 960 rpm

SAOM 1000-400-08C Outlet Area: 0.793 m²

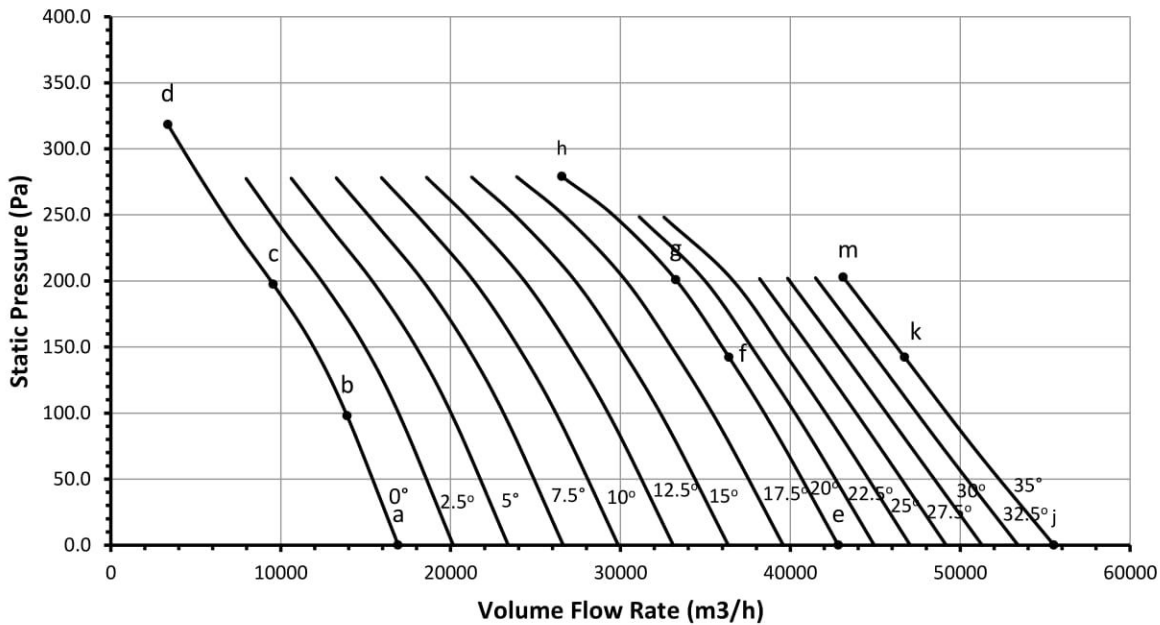
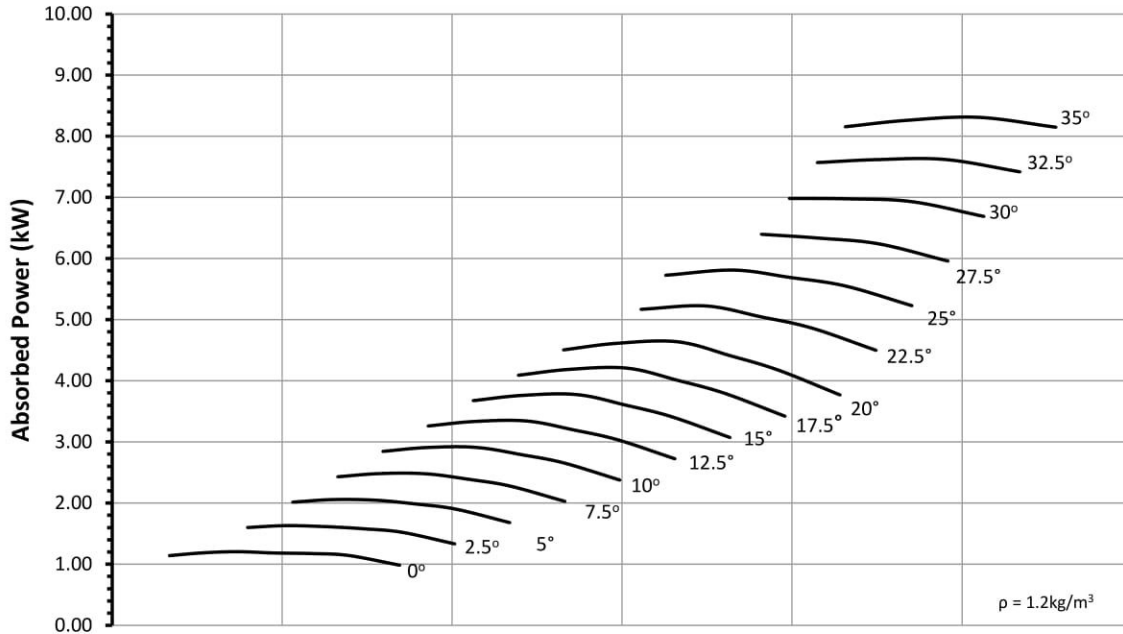

Ref	Full Octave Band Center Frequency								L _{WA} dB(A)
	63	125	250	500	1K	2K	4K	8K	
a	91	90	90	90	89	85	78	70	93
b	92	91	93	92	87	82	75	67	93
c	103	97	91	88	84	80	74	66	90
d	99	94	89	86	83	82	77	73	90
e	96	97	95	90	86	84	79	72	93
f	95	96	94	88	84	82	78	72	91
g	95	95	93	88	84	83	79	73	91
h	96	100	98	93	89	86	81	75	96
j	99	101	98	93	89	86	82	77	96
k	97	98	96	92	89	86	82	78	95
m	98	100	97	92	89	86	82	78	95



Performance certified is for Installation type D: Ducted Inlet- Ducted Outlet. Performance ratings do not include the effects of appurtenances (accessories)
 Power rating kW is fan input power.
 The Sound Power Level ratings shown are in decibels, referred to 10⁻¹² watts, calculated per AMCA International Standard 301. Values shown are for inlet L_{WA} and L_{WA}A sound power levels for Installation type D: Ducted Inlet-Ducted Outlet. Ratings include the effects of duct end correction.
 The A-weighted sound ratings shown have been calculated per AMCA International Standard 301.

Performance Curve

AAOM 1120-400-12C 50Hz 960 rpm

FEG 56

SAOM 1120-400-12C Outlet Area: 0.994 m²

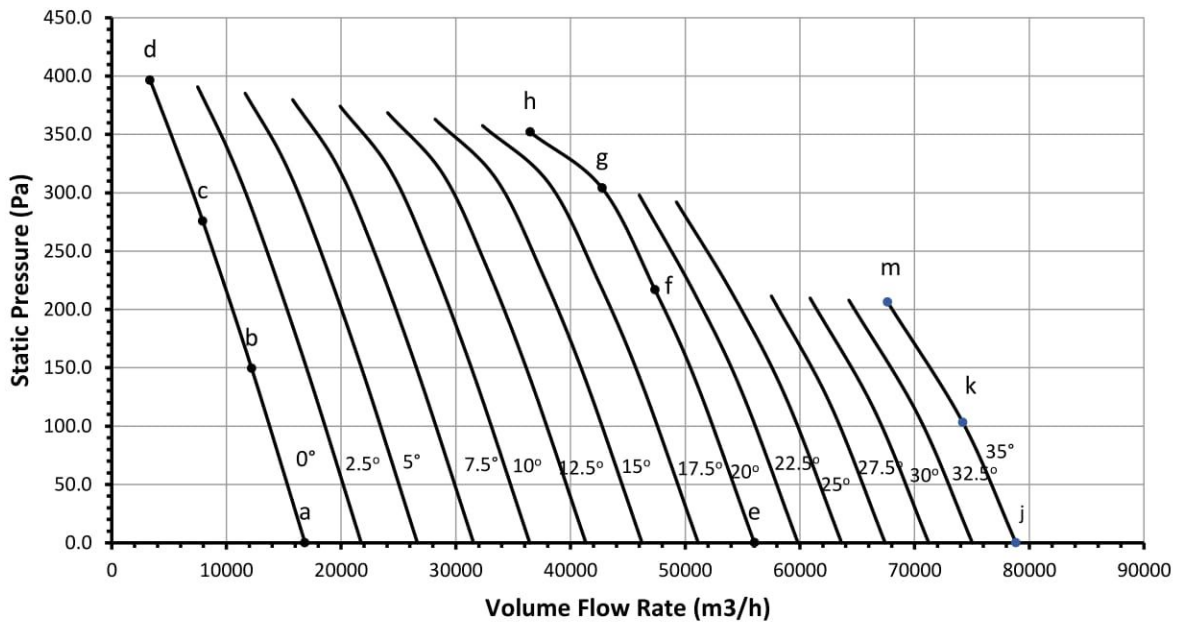
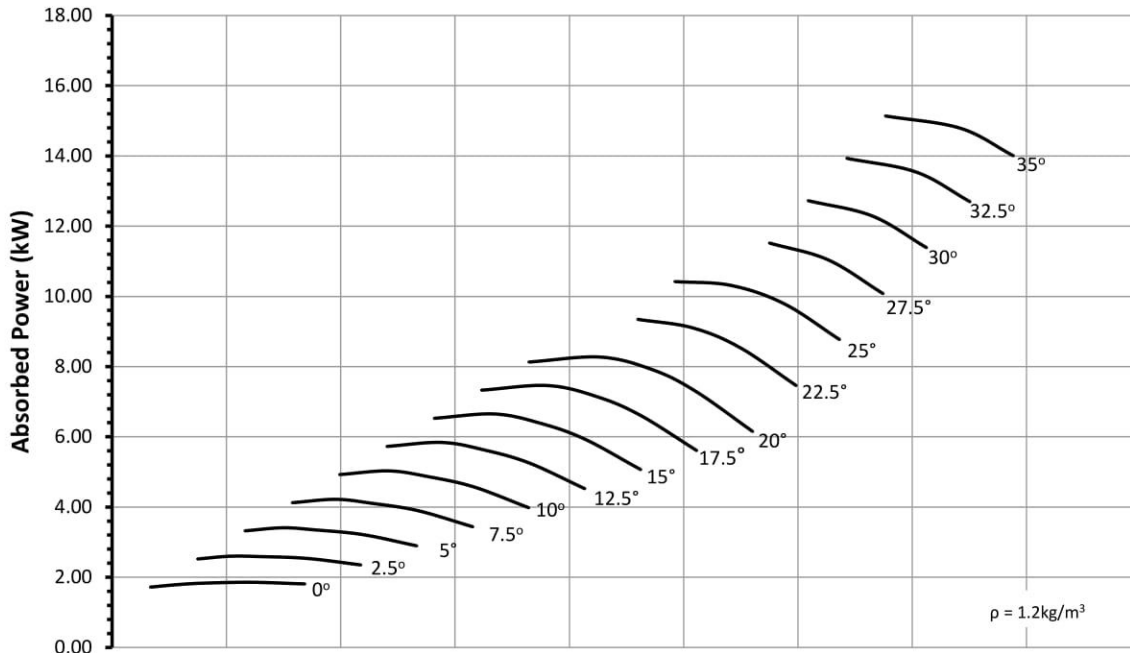

Ref	Full Octave Band Center Frequency								L _{WA} dB(A)
	63	125	250	500	1K	2K	4K	8K	
a	97	99	100	95	92	88	83	74	98
b	98	98	99	92	89	86	80	72	95
c	97	96	95	89	88	86	80	72	93
d	98	98	97	90	88	86	81	76	94
e	101	101	101	93	91	89	85	78	98
f	102	102	102	92	89	87	84	77	97
g	102	102	102	96	93	90	85	78	99
h	105	106	106	99	95	90	84	77	102
j	106	105	104	96	93	89	85	80	100
k	105	105	105	95	92	89	85	80	100
m	106	104	102	96	93	89	86	81	99



Performance certified is for Installation type D: Ducted Inlet- Ducted Outlet. Performance ratings do not include the effects of appurtenances (accessories) Power rating kW is fan input power. The Sound Power Level ratings shown are in decibels, referred to 10⁻¹² watts, calculated per AMCA International Standard 301. Values shown are for inlet L_{WA} and L_{WA} sound power levels for Installation type D: Ducted Inlet-Ducted Outlet. Ratings include the effects of duct end correction. The A-weighted sound ratings shown have been calculated per AMCA International Standard 301.

Performance Curve

AAOM 1250-400-12C 50Hz 960 rpm

FEG 63

SAOM 1250-400-12C Outlet Area: 1.237 m²

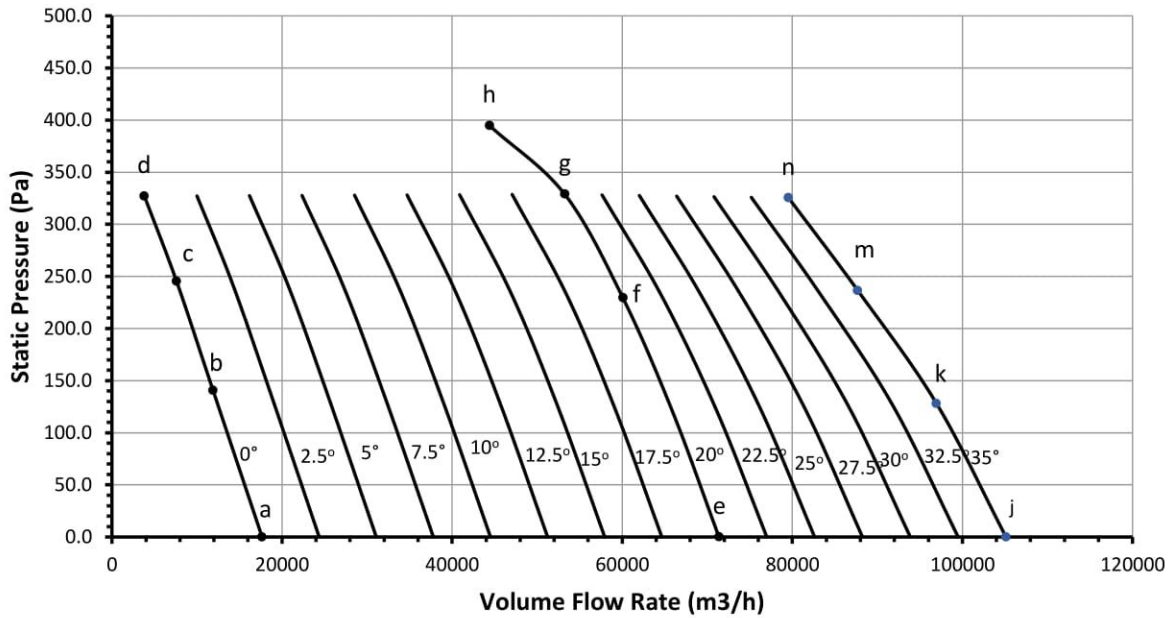
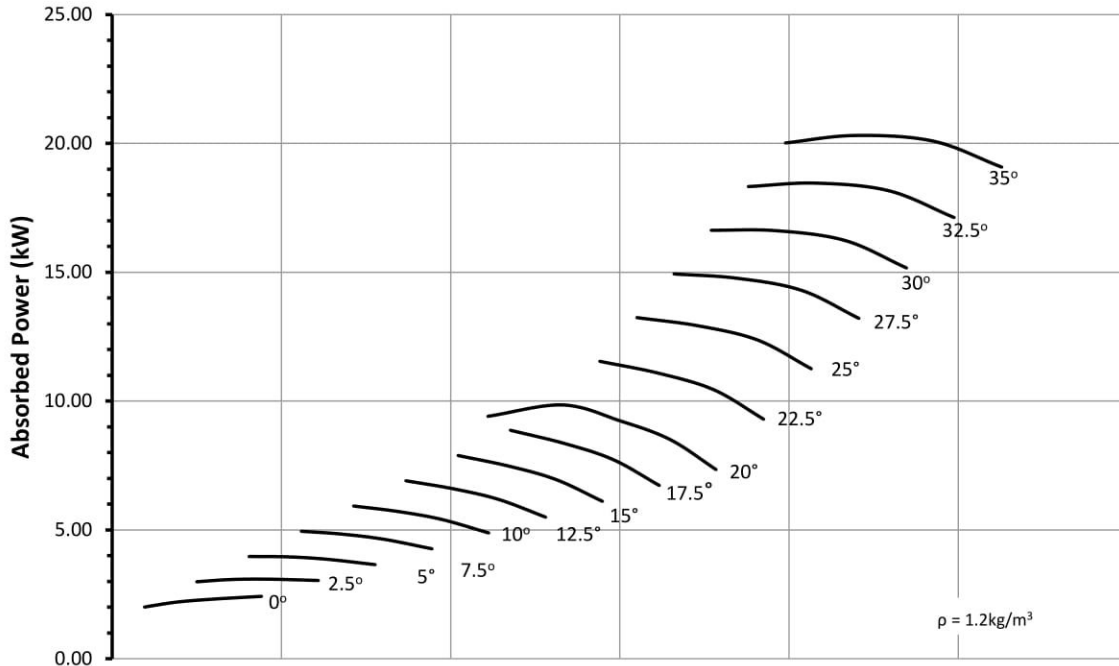

Ref	Full Octave Band Center Frequency								L _W A dB(A)
	63	125	250	500	1K	2K	4K	8K	
a	102	101	100	96	94	91	86	77	99
b	99	96	94	93	93	90	83	74	97
c	99	96	93	93	92	89	84	75	96
d	100	96	93	92	92	89	84	78	96
e	102	100	100	98	94	92	90	83	100
f	101	99	100	100	98	95	90	82	102
g	102	104	106	103	99	94	88	81	104
h	111	110	110	101	97	92	86	80	105
j	109	105	102	100	96	92	89	83	102
k	108	104	101	100	96	93	89	84	102
m	107	104	102	101	98	95	90	85	103
n	110	109	109	103	100	96	91	85	106



Performance certified is for Installation type D: Ducted Inlet- Ducted Outlet. Performance ratings do not include the effects of appurtenances (accessories) Power rating kW is fan input power. The Sound Power Level ratings shown are in decibels, referred to 10⁻¹² watts, calculated per AMCA International Standard 301. Values shown are for inlet L_Wi and L_WA sound power levels for Installation type D: Ducted Inlet-Ducted Outlet. Ratings include the effects of duct end correction. The A-weighted sound ratings shown have been calculated per AMCA International Standard 301.

Performance Curve

AAOM 710-230-12B

50Hz 720 rpm

FEG 63

SAOM 710-230-12B

Outlet Area: 0.396 m²

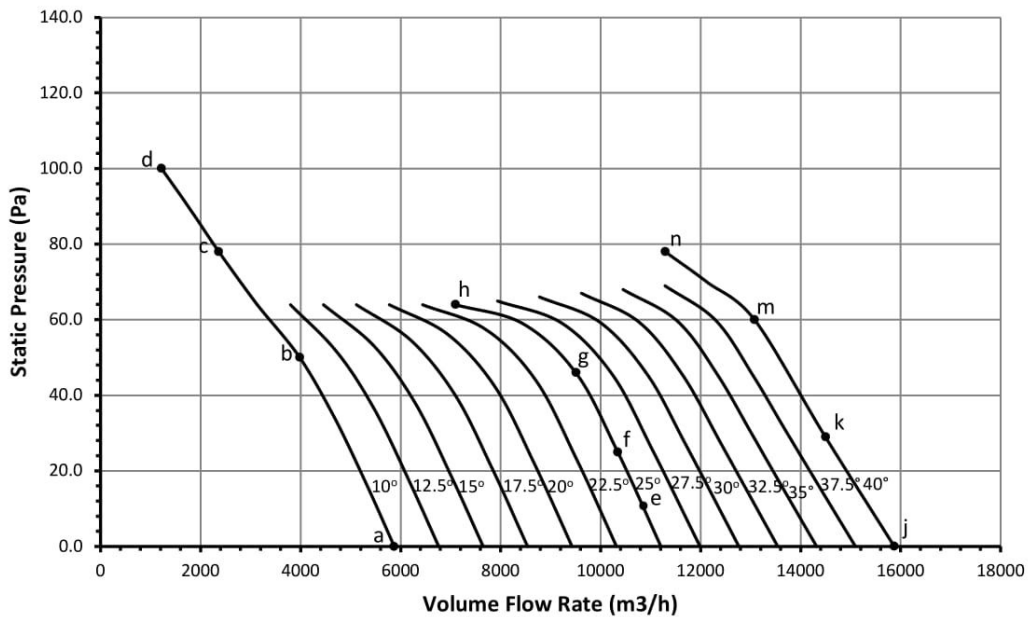
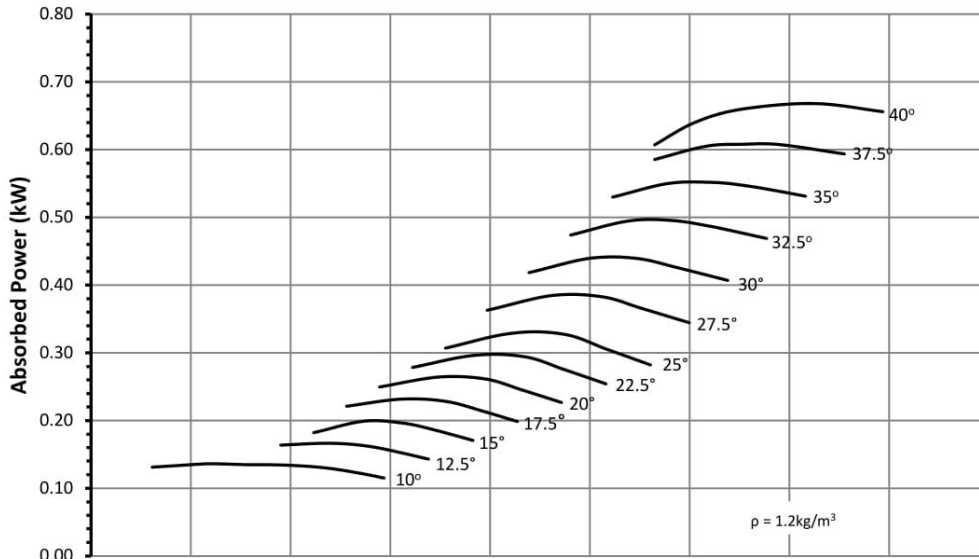

Ref	Full Octave Band Center Frequency								L _{WA} dB(A)
	63	125	250	500	1K	2K	4K	8K	
a	82	79	72	72	71	69	62	56	76
b	80	84	76	74	70	67	60	52	76
c	79	82	70	69	68	65	59	51	73
d	80	79	70	69	68	66	61	54	73
e	89	83	75	73	71	70	65	58	77
f	87	82	76	73	72	70	65	58	77
g	85	83	79	75	73	70	64	57	78
h	89	90	79	76	72	68	62	55	79
j	88	80	76	72	72	71	67	61	77
k	87	79	73	71	71	70	67	61	77
m	88	81	73	71	71	71	67	61	77
n	91	85	77	74	73	71	67	61	79



Performance certified is for Installation type D: Ducted Inlet-Ducted Outlet. Performance ratings do not include the effects of appurtenances (accessories). Power rating kW is fan input power. The Sound Power Level ratings shown are in decibels, referred to 10⁻¹² watts, calculated per AMCA International Standard 301. Values shown are for inlet L_{WA} and L_{WA} sound power levels for Installation type D: Ducted Inlet-Ducted Outlet. Ratings include the effects of duct end correction. The A-weighted sound ratings shown have been calculated per AMCA International Standard 301.

Performance Curve

AAOM 800-400-08C

50Hz 720 rpm

FEG 50

SAOM 800-400-08C

Outlet Area: 0.509 m²

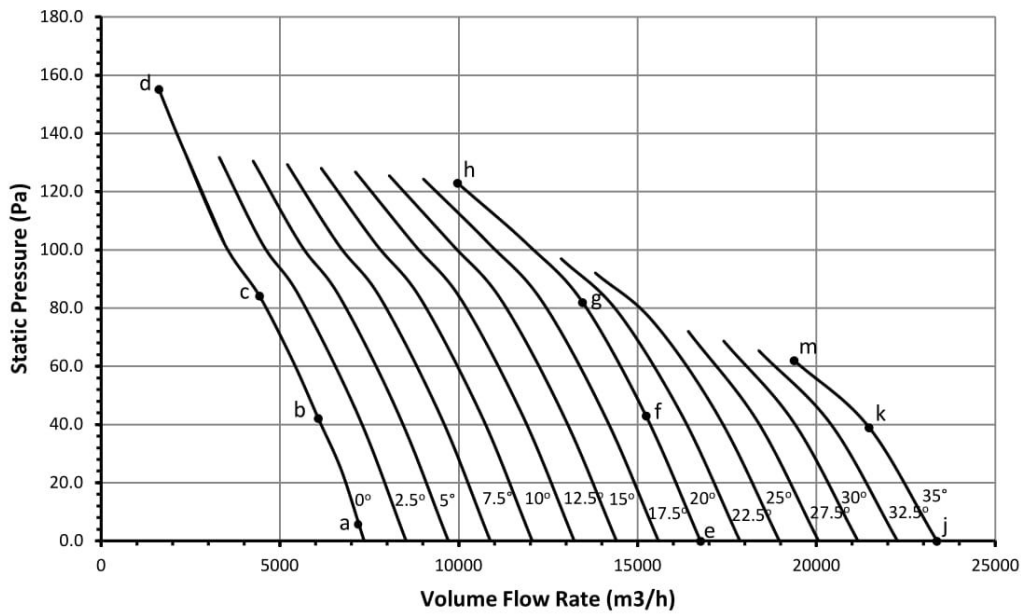
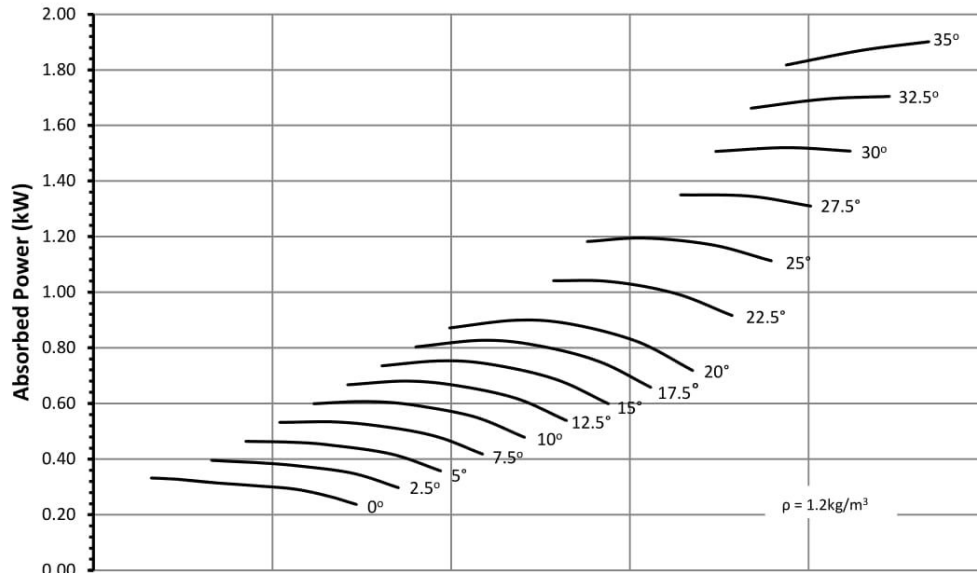

Ref	Full Octave Band Center Frequency								L _{WA} dB(A)
	63	125	250	500	1K	2K	4K	8K	
a	85	85	79	74	72	68	59	54	78
b	85	84	81	77	75	68	59	53	79
c	91	87	80	75	71	64	58	52	78
d	95	85	78	74	72	68	62	62	78
e	92	91	80	76	72	68	60	57	80
f	92	90	78	74	71	67	59	57	79
g	92	91	77	73	71	68	60	57	78
h	93	89	79	75	73	69	63	59	79
j	97	96	84	81	78	73	68	64	85
k	95	97	83	80	77	73	67	64	84
m	93	94	81	79	77	73	68	67	83



Performance certified is for Installation type D: Ducted Inlet-Ducted Outlet. Performance ratings do not include the effects of appurtenances (accessories)
 Power rating kW is fan input power.
 The Sound Power Level ratings shown are in decibels, referred to 10⁻¹² watts, calculated per AMCA International Standard 301. Values shown are for inlet L_{WA} and L_{WA} sound power levels for Installation type D: Ducted Inlet-Ducted Outlet. Ratings include the effects of duct end correction.
 The A-weighted sound ratings shown have been calculated per AMCA International Standard 301.

Performance Curve

AAOM 900-400-08C

50Hz 720 rpm

FEG 53

SAOM 900-400-08C

Outlet Area: 0.643 m²

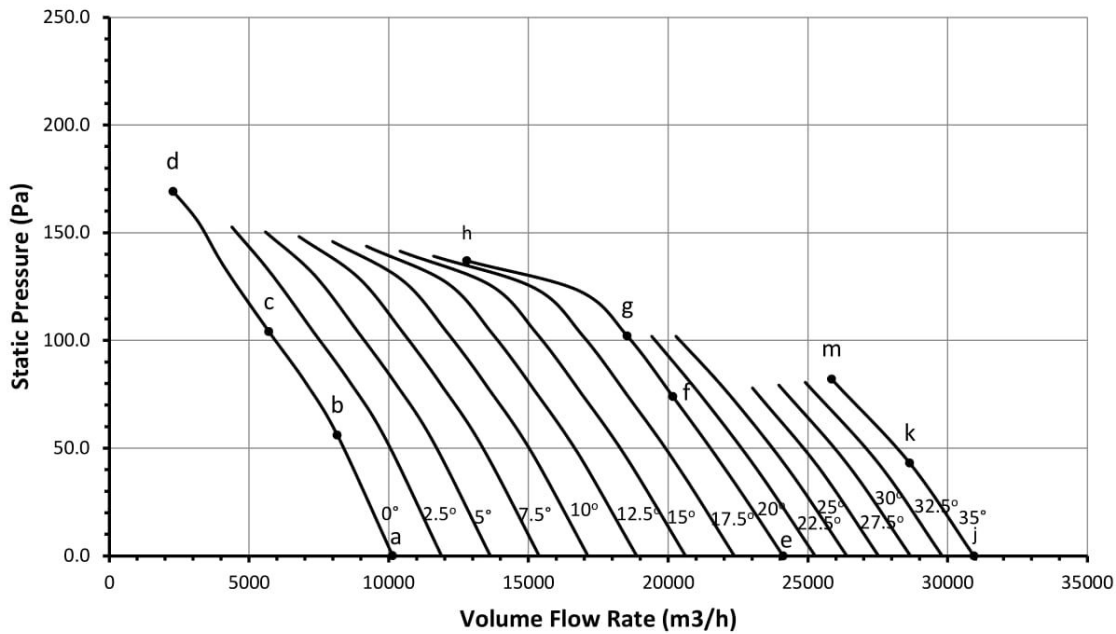
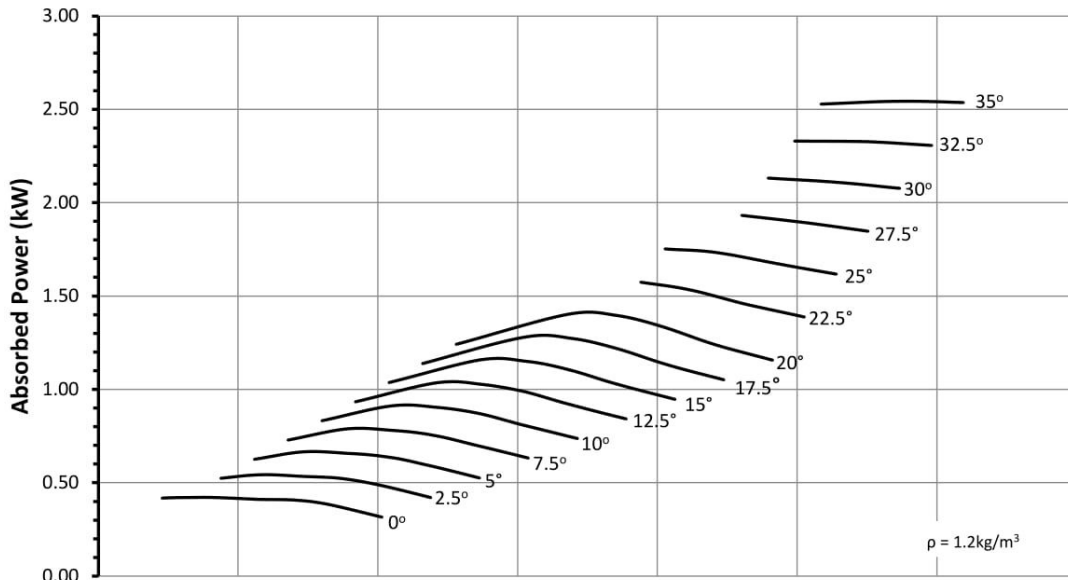

Ref	Full Octave Band Center Frequency								L _{WA} dB(A)
	63	125	250	500	1K	2K	4K	8K	
a	83	80	81	80	78	74	65	58	82
b	83	79	82	82	79	72	64	57	83
c	91	84	84	79	75	69	62	55	81
d	95	85	79	75	73	71	65	60	79
e	89	87	83	78	75	74	66	60	82
f	89	86	81	75	73	72	66	61	80
g	89	86	81	76	73	73	67	62	80
h	90	85	82	77	75	74	68	63	81
j	93	90	87	82	78	76	71	67	85
k	92	89	86	81	78	76	71	67	84
m	91	88	85	80	77	76	71	67	84



Performance certified is for Installation type D: Ducted Inlet- Ducted Outlet. Performance ratings do not include the effects of appurtenances (accessories)
 Power rating kW is fan input power.
 The Sound Power Level ratings shown are in decibels, referred to 10⁻¹² watts, calculated per AMCA International Standard 301. Values shown are for inlet L_{WA} and L_{WA} sound power levels for Installation type D: Ducted Inlet-Ducted Outlet. Ratings include the effects of duct end correction.
 The A-weighted sound ratings shown have been calculated per AMCA International Standard 301.

Performance Curve

AAOM 1000-400-08C 50Hz 720 rpm

FEG 60

SAOM 1000-400-08C

Outlet Area: 0.793 m²

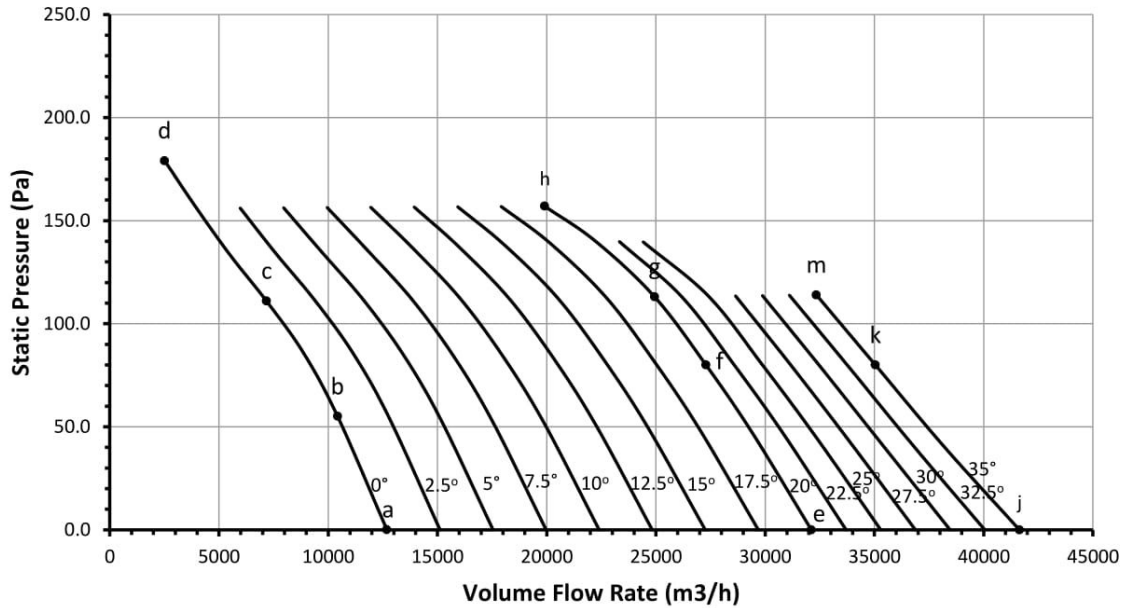
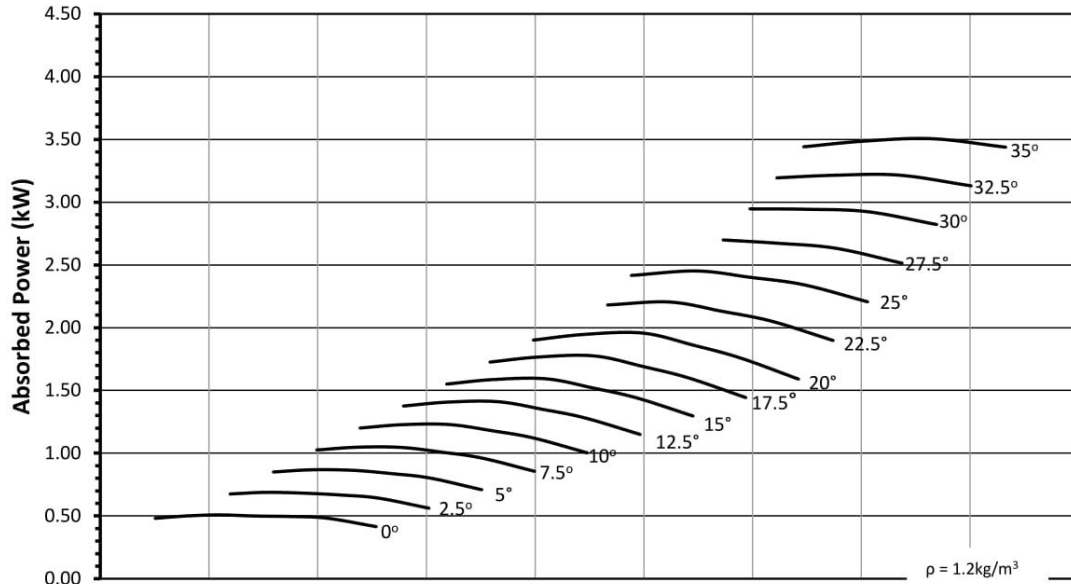

Ref	Full Octave Band Center Frequency								L _W A
	63	125	250	500	1K	2K	4K	8K	
a	85	83	84	84	82	77	69	60	86
b	85	84	88	84	79	74	66	58	85
c	97	86	84	80	77	73	64	57	82
d	92	85	82	78	77	75	68	65	82
e	90	91	87	82	78	77	71	63	85
f	88	90	86	79	77	75	70	63	83
g	89	89	85	79	77	76	71	64	83
h	90	94	91	85	82	78	72	66	88
j	92	95	90	85	81	79	74	69	88
k	91	92	88	84	82	79	74	70	87
m	91	94	88	84	82	79	74	70	88



Performance certified is for Installation type D: Ducted Inlet- Ducted Outlet. Performance ratings do not include the effects of appurtenances (accessories)
 Power rating kW is fan input power.
 The Sound Power Level ratings shown are in decibels, referred to 10⁻¹² watts, calculated per AMCA International Standard 301. Values shown are for inlet L_W and L_WA sound power levels for Installation type D: Ducted Inlet-Ducted Outlet. Ratings include the effects of duct end correction.
 The A-weighted sound ratings shown have been calculated per AMCA International Standard 301.

Performance Curve

AAOM 1120-400-12C 50Hz 720 rpm

FEG 56

SAOM 1120-400-12C Outlet Area: 0.994 m²

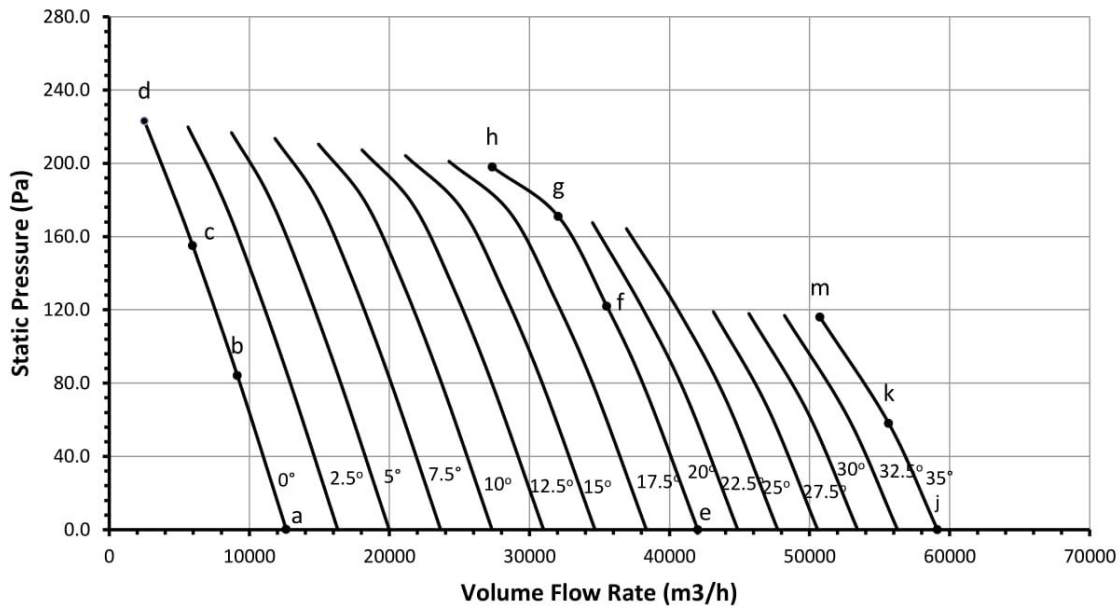
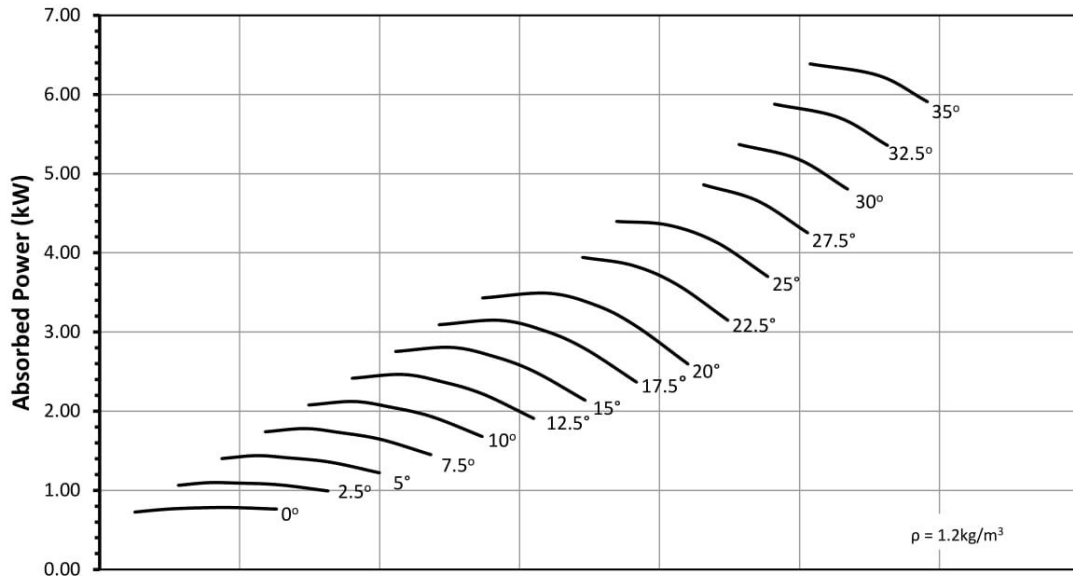

Ref	Full Octave Band Center Frequency								L _W /A dB(A)
	63	125	250	500	1K	2K	4K	8K	
a	91	94	91	87	84	81	74	64	90
b	92	92	87	85	82	79	70	62	87
c	91	88	84	83	81	78	70	63	86
d	92	91	85	83	81	78	72	68	86
e	95	95	89	86	83	82	77	68	89
f	96	96	87	84	83	80	76	68	88
g	96	96	92	88	86	82	77	69	91
h	99	100	95	91	87	82	75	68	93
j	100	98	92	88	85	81	77	71	91
k	99	99	91	88	85	81	78	72	91
m	100	96	91	88	85	82	78	73	91



Performance certified is for Installation type D: Ducted Inlet- Ducted Outlet. Performance ratings do not include the effects of appurtenances (accessories)
 Power rating kW is fan input power.
 The Sound Power Level ratings shown are in decibels, referred to 10⁻¹² watts, calculated per AMCA International Standard 301. Values shown are for inlet L_W and L_W/A sound power levels for Installation type D: Ducted Inlet-Ducted Outlet. Ratings include the effects of duct end correction.
 The A-weighted sound ratings shown have been calculated per AMCA International Standard 301.

Performance Curve

AAOM 1250-400-12C 50Hz 720 rpm

FEG 63

SAOM 1250-400-12C Outlet Area: 1.237 m²

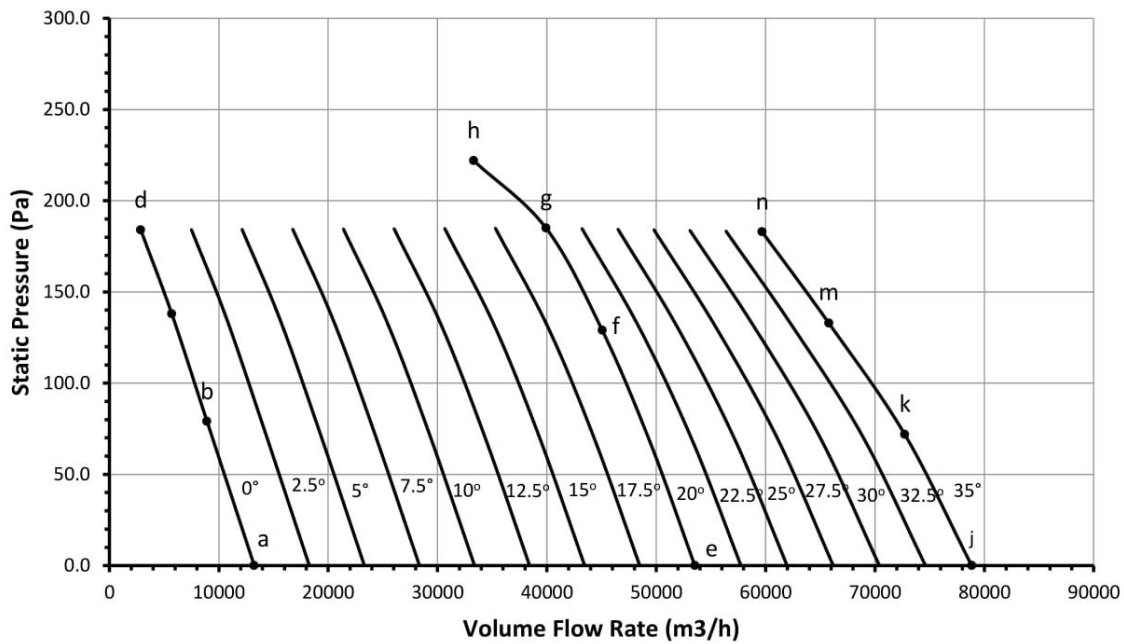
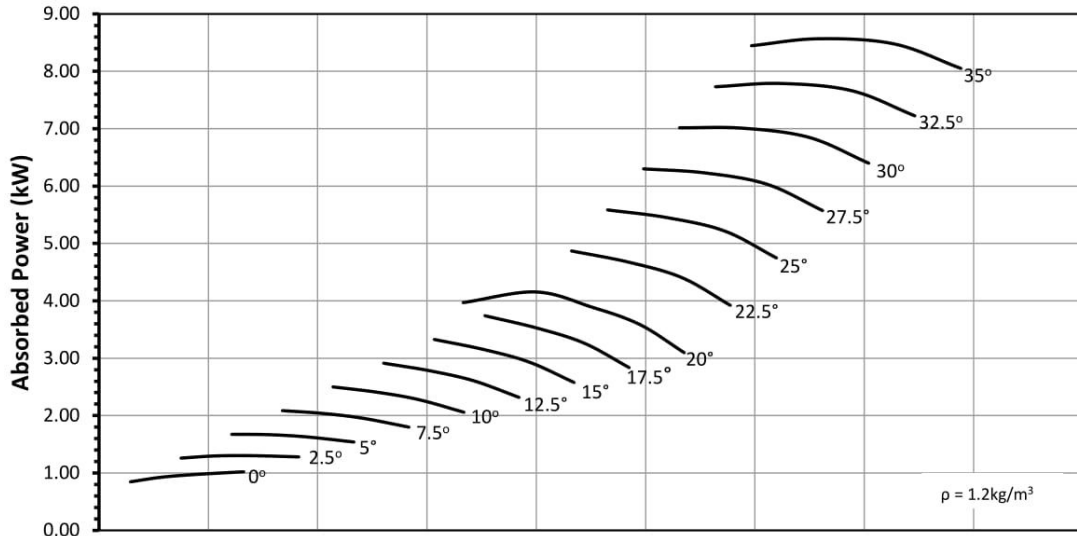

Ref	Full Octave Band Center Frequency							L _{WA} dB(A)	
	63	125	250	500	1K	2K	4K		8K
a	95	94	92	89	87	83	77	66	92
b	92	88	86	88	86	82	74	64	90
c	93	87	86	87	85	82	75	65	89
d	93	87	86	86	85	82	76	68	89
e	96	92	95	89	87	86	82	72	93
f	95	92	95	92	91	87	81	72	95
g	96	100	99	95	91	86	79	71	97
h	104	104	98	93	90	84	77	71	96
j	103	96	97	91	88	85	81	74	94
k	102	94	96	92	89	86	81	76	94
m	101	95	96	93	91	87	82	77	96
n	104	103	98	96	93	88	82	76	98



Performance certified is for Installation type D: Ducted Inlet-Ducted Outlet. Performance ratings do not include the effects of appurtenances (accessories)
 Power rating kW is fan input power.
 The Sound Power Level ratings shown are in decibels, referred to 10⁻¹² watts, calculated per AMCA International Standard 301. Values shown are for inlet L_{WA} and L_{WA} sound power levels for Installation type D: Ducted Inlet-Ducted Outlet. Ratings include the effects of duct end correction.
 The A-weighted sound ratings shown have been calculated per AMCA International Standard 301.

DLK[®]

VENTILATOREN



DLK Ventilatoren GmbH

Ziegeleistraße 18
D-74214 Schöntal-Berlichingen
Germany

fon: +49(0) 7943 – 9102 – 0

fax: +49(0) 7943 – 9102 – 10

mail: info@dlk.com

DLK Ventilatoren Sdn Bhd

No 22, Jalan Mega 2/1
Kawasan Perindustrian Mega 2
43500 Semenyih
Selangor, Malaysia

fon : +603 8725 0845

mail: sales.asia@dlk.com

www.dlkasia.com