



American
VENTUS

2025





01

VTS Group

1.1	VTS Group	05
1.2	The 3 Elements of Success	08

02

Designer support

2.1	ClimaCAD Online 4.0 [CCOL 4]	12
2.2	VTS BIM	14

03

Units

3.1	AVS	18
3.2	AVS Lite / AVS Vertical	19
3.3	American Ventus	20
3.4	Design	22
3.5	Air Tightness	24
3.5	Rooftop Applications	26

04

Technical Parameters

4.1	AVS 8-55 - Supply & Exhaust	30
4.2	AVS 65-380 - Supply & Exhaust	32
4.3	AVS 8-55 - Cross-Flow Plate	34
4.4	AVS 65-380 - Cross-Flow Plate	38
4.5	AVS 12-65 with Energy Wheel	44
4.6	AVS 85-380 with Energy Wheel	46
4.7	AVS Lite 8-40 - Supply & Exhaust	50
4.8	AVS Lite 8-40 - Cross-Flow Plate	52
4.9	AVS Lite 12-40 with Energy Wheel	55
4.10	AVS - Vertical Configurations	58

05

Connection and Controls

5.1	Connecting Point	62
5.2	Construction and Wiring	63
5.3	Controls	64
5.4	Main Elements	65
5.5	Control Applications List	68
5.6	Supply Ahus	69

06

Functions

6.1	Functions	78
6.2	Psychrometric Chart	81
6.3	Customer Testimonies	84
6.4	Symbols and Labels	85



01

VTS Group



VTS GROUP is a manufacturer of technologically advanced equipment for the HVAC Sector; using innovative technologies in the spheres of project research, production and logistics.

OUR MISSION
AHU#1

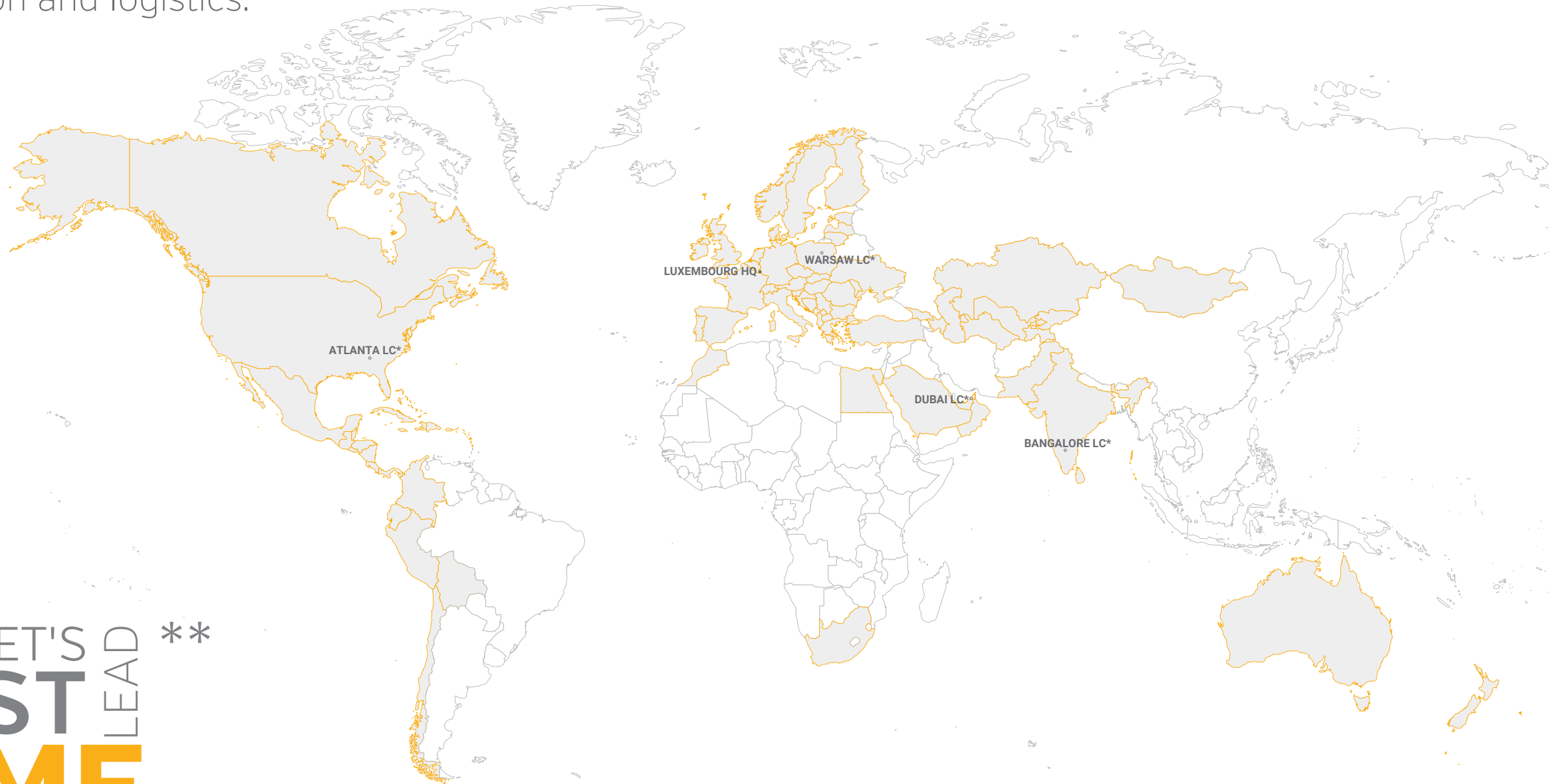

MARKET'S **BEST** LEAD **TIME** **

* Logistics center

** Factory will confirm lead time based on the units selected.





THE 3 ELEMENTS OF SUCCESS

Consistently superior product quality. Unbeatable market prices. The shortest lead time. These three elements of market policy ensure that VTS is always one step ahead, in every region of the world.

Following the proven assembly method of the automotive Industry, VTS created a network of 4 efficiently functioning logistics centers: **Atlanta, Dubai, Warsaw and Bangalore**. Thereby guaranteeing the shortest delivery terms in the market, regardless of the region in the world.

Mass scale production of reproducible devices makes it possible for VTS to offer our product at the **most competitive price while retaining the best quality**.

Multilevel quality control systems enables VTS to offer a **18 months warranty for each unit**.

MARKET'S **BEST** LEAD TIME

4 LOGISTICS CENTERS

\$ **competitive price**

150 000 UNITS SOLD ANNUALLY

the highest **quality**

18 MONTHS **warranty** FOR EACH UNIT





02

Designer support

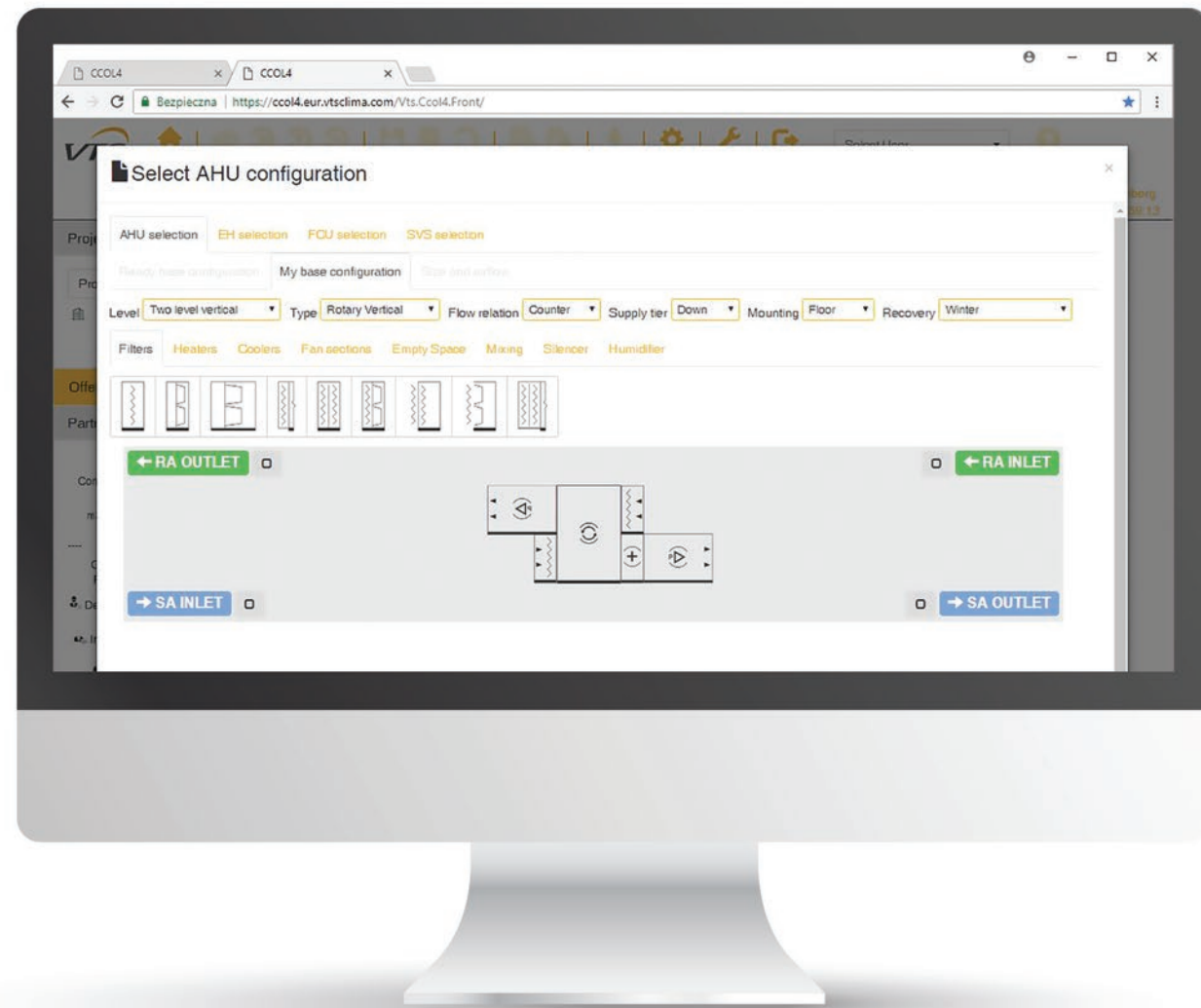



ClimaCAD Online 4.0 [CCOL 4]

Customized configuration

User friendly interface



Fast&Easy selection

Integrated with CRM, ERP, WMA system

CCOL 4 IS ADJUST TO

» all browsers



» all operating system



» all devices



DATA EXPORT TO



CCOL 4.0 uses the latest technology and development platforms, which will be accessible from anywhere in the world through our software as service models. All you need is a device with a web browser and access to the internet.

THE VERSATILITY OF DESIGNING

- » unlimited number of device configurations
- » detection of illogical configurations



DYNAMIC COUNTING OF DEVICES DIMENSIONS

- » CCOL offers the optimal length of the control panel and the optimal section length adapted to the device functions and device design

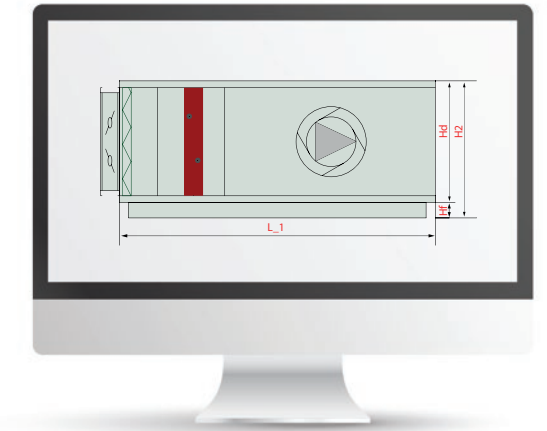

MANAGING YOUR OWN DATABASE

- » the possibility of creating your own project database (selection)
- » the possibility of exporting own selections to quotation by VTS technical engineers

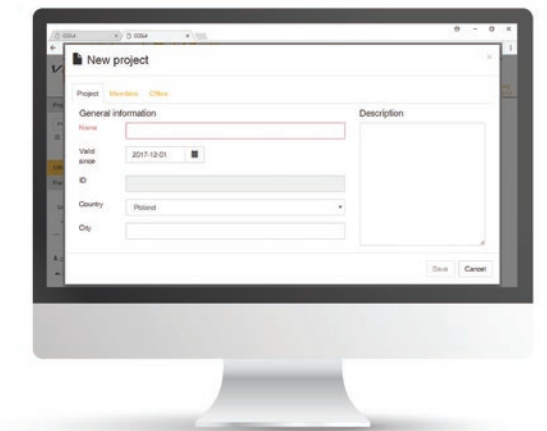

www.ccol4.com



VTS BIM - a new approach to digital models of air-handling units

VTS has created the possibility of generating digital models of VENTUS VS and American VENTUS air-handling models on-line. This is possible thanks to the implementation of a new ClimaCAD OnLine 4.0 selection tool, equipped with .rfa (Revit®) files generator.

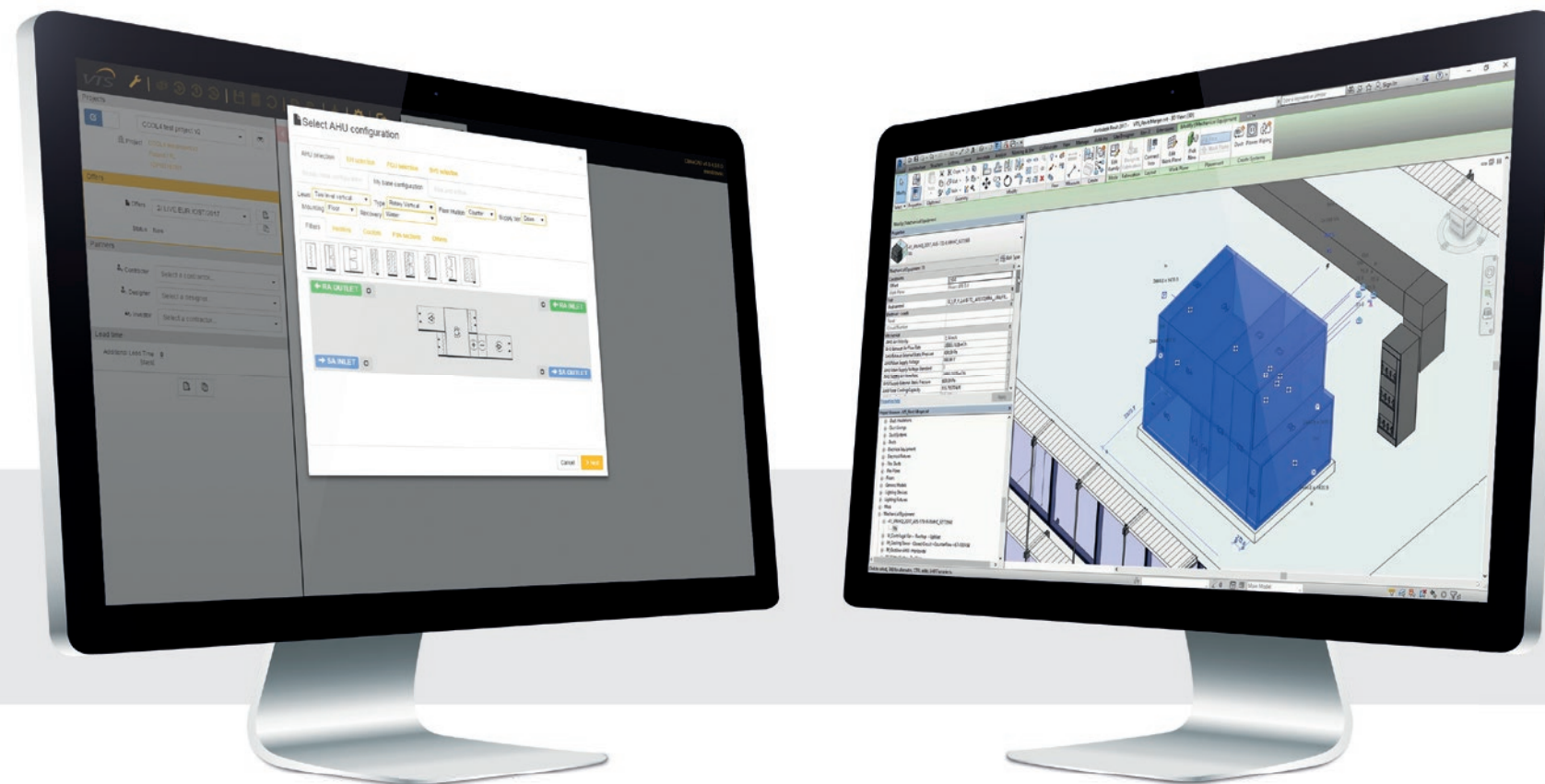

The release of families for the Autodesk Revit® environment by VTS makes it easier to design agencies for model the building installations on the basis of using the same platform. At present the on-line generator is a unique solution in BIM environment. It enables the generation of a VENTUS air-handling unit model practically in no time in any configuration and with any parameters.

The process of model generation comes down to the following 3 steps:



1

Login to CCOL 4.0 website

Login to the CCOL 4.0 using the following web address:

www.ccol4.com

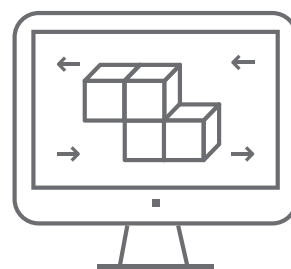

2

Unit configuration

Use the intuitive selection tool to select your Air Handling Unit and set its working parameters to fit the specified project demands.

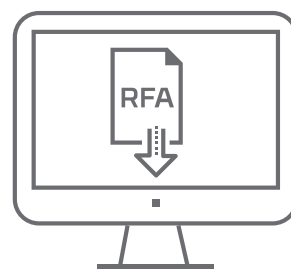

3

Data export to .rfa file

In order to generate a model in .rfa file, it is enough to enter the name and surname plus the email address of the person dedicated to receive the file. The system will automatically send a link to download the model. The entire process lasts approximately 15 minutes.

As a result, the client receives:

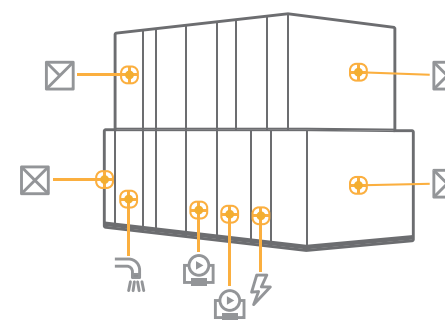

The generated objects contain detailed parameters connectors:

- » air systems,
- » hydraulic systems,
- » sanitary systems,
- » electric systems,

as well as the complete dimensional data, the device maintenance zone and the service (repair) zone.

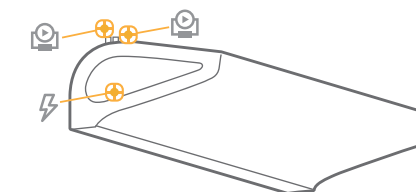
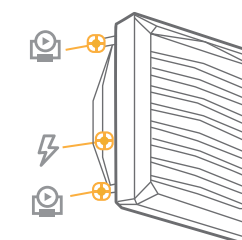

VTS also provides digital models of WING air curtains and VOLCANO air heaters.

The models contain:

- » parametrized electric and hydraulic connectors,
- » mount options vertically and horizontally,
- » presentation of the range of air stream,
- » parameter of any inclination angle of an air heater in relation to the horizontal plane.

Models can be downloaded from: <https://vtsgroup.com/us/vts-bim>



03

Units



AVS

from **800 CFM**
to **38 000 CFM**
in total **capacity**

**premium efficiency motors
energy recovery system:**
- cross-flow plate
- energy wheel

2 000 h
salt spray test
resistance
on the external coating

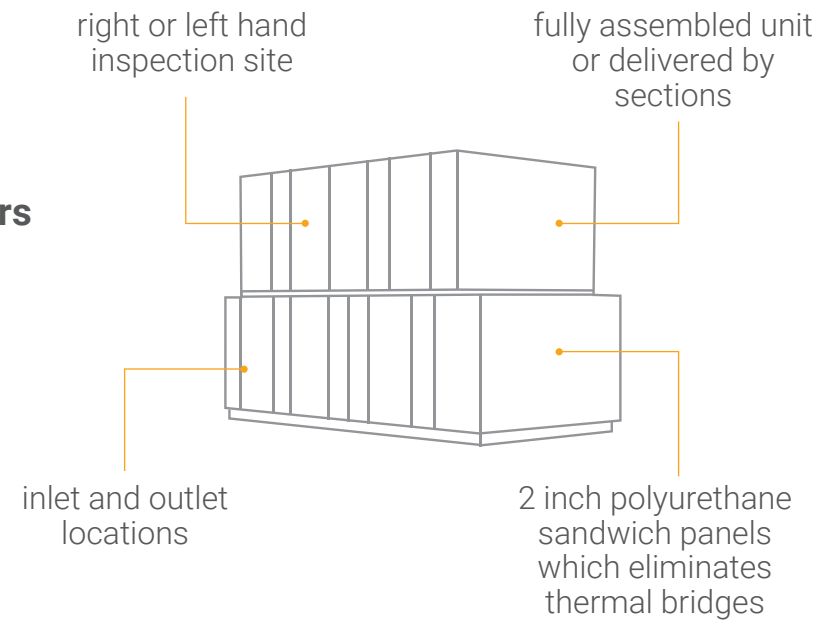

AVS LITE

from **800 CFM**
to **4 000 CFM**
in total **capacity**

**premium efficiency motors
energy recovery system:**
- cross-flow plate
- energy wheel

2 000 h
salt spray test
resistance
on the external coating

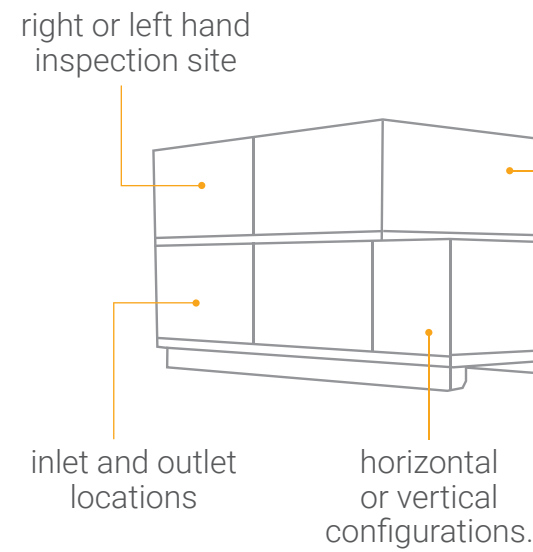

AVS VERTICAL

from **800 CFM**
to **4 000 CFM**
in total **capacity**

premium efficiency motors

2 000 h
salt spray test
resistance
on the external coating

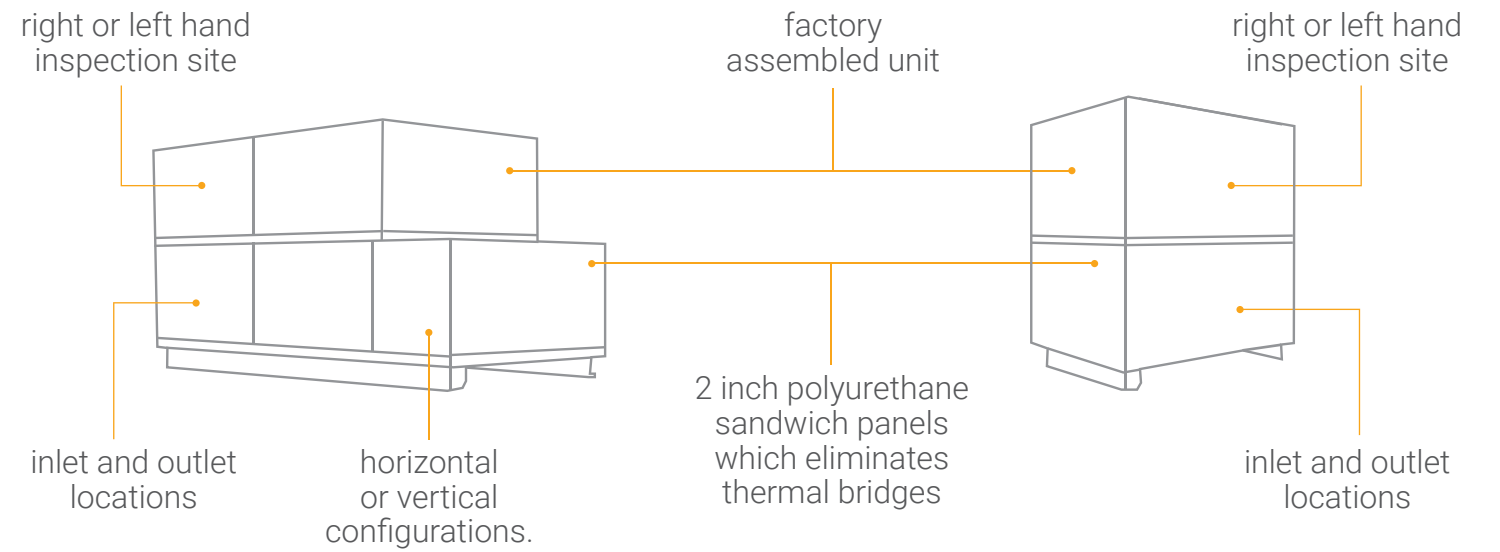



American
VENTUS



RELIABLE
AND TIGHT
CONSTRUCTION

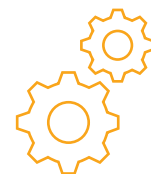

TOP QUALITY
COMPONENTS



INTELLIGENT
CONTROLS
SYSTEMS



SAFETY
OF USE



DESIGN



MORE THAN 2,000 HOURS SALT SPRAY TEST PROTECTION

RESISTANCE TO CORROSION

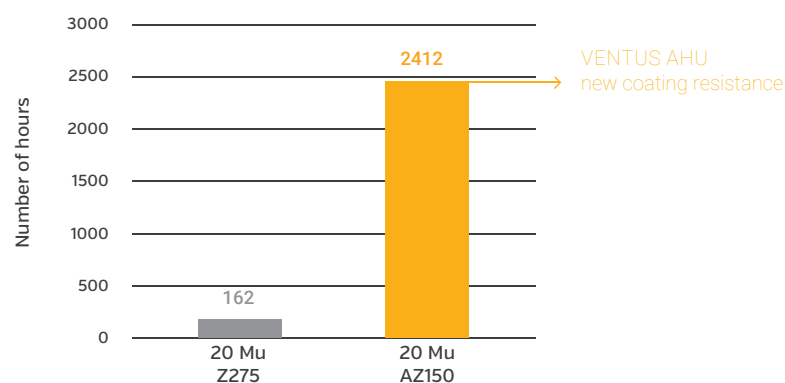

Salt spray test according to ASATMB - 117



ALUMINUM POSTS
AS **STANDARD** FOR ALL TYPES OF UNITS



FAN SECTION CAGE

- » high longitudinal stiffness of the structure
- » easy section assembly

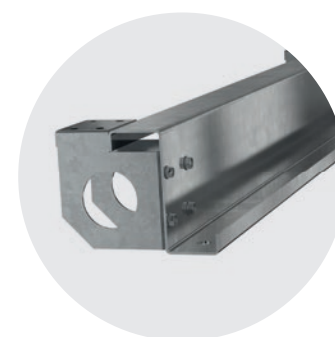

Z PROFILE
AVS040-AVS085



C PROFILE
AVS100-AVS380



CURB READY RAILS
AVS040-AVS380

GALVANIZED STEEL SUPPORT
AS **STANDARD** FOR ALL TYPES OF UNITS

CONVENIENT

- » easy transport
- » great profile resistance to deflection

STRUCTURAL POSTS

- » thermally broken as standard
- » high resistance to weather conditions and UV radiation

CASING SKIN

- » high rigidity and durability of the AHU structure
- » low absorption of heat radiation and UV
- » perfect resistance to weather conditions



AIR TIGHTNESS



ERGONOMIC INSPECTION PANEL LOCK

- » Highly aesthetic and ergonomic handles securing perfect tightness of inspection panels.

* patent pending; information will be published after it's formal validation.

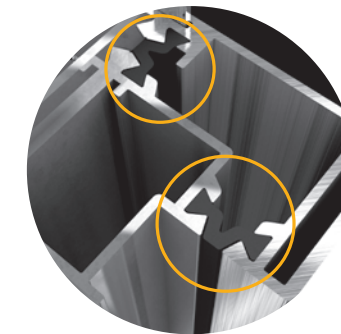
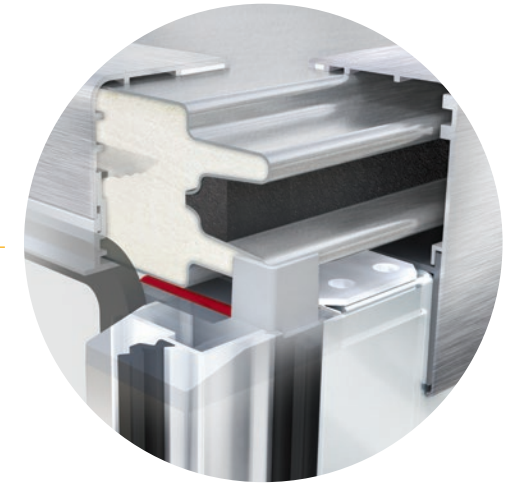

THERMAL BREAK

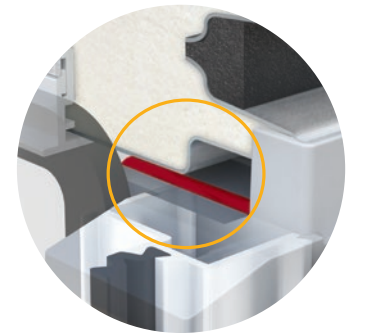

ADDITIONAL POST SEALING

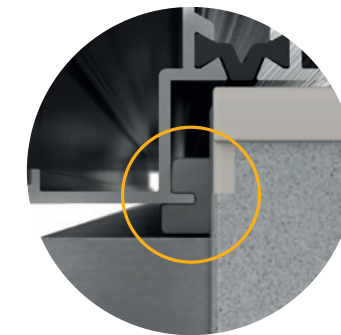

LABYRINTH SEALING



ADDITIONAL SEALING EDGE

ALUMINUM STRUCTURAL POSTS WITH AN ADDITIONAL SEALING FIN AND A THERMAL INSERT

- » thermal break as standard - ensures no condensation outside the AHU
- » the fin ensures labyrinth sealing – currently the most effective solution on the market, mainly used in laboratory equipment
- » original solution consisting in the use of symmetrical channel tension filled with a sealing compound, which provides 100% tightness of the connection between the column and construction structure



ROOFTOP APPLICATIONS

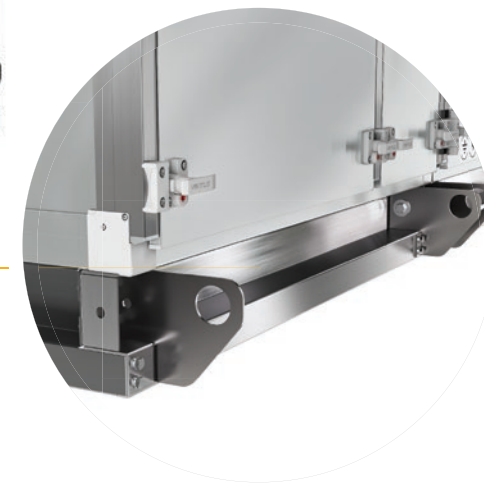

SECTIONAL ROOF

- » prevents water penetration during service
- » additional weather protection

VARIABLE INTAKE CONFIGURATIONS

- » top, bottom and side intake options
- » end – optional full face intake damper available units
- » dampers:
 - gear system for even distribution of the torque
 - extruded aluminum construction
 - low leakage
 - double wall blade construction

CURB READY RAILS

- » design -overhangs the side of the curb to avoid the need of flashing
- » integrated lifting lugs

VARIABLE DISCHARGE CONFIGURATION

- » end, top, bottom and side discharge options
- » optional discharge dampers and full end discharge dampers available



04

Technical
Parameters



AVS 8-55 - SUPPLY & EXHAUST

Rated parameters		Recommended range of airflow																											
Size		AVS 008		AVS 012		AVS 016		AVS 020		AVS 030		AVS 040		AVS 055															
15 000	[CFM]	[Bar chart showing airflow ranges for each unit size]																											
10 000		[Bar chart showing airflow ranges for each unit size]																											
5 000		[Bar chart showing airflow ranges for each unit size]																											
0		[Bar chart showing airflow ranges for each unit size]																											
Min.		332	427	427	427	480	618	618	618	636	819	819	819	806	1037	1037	1037	1185	1524	1524	1524	1567	1945	1945	1945	2003	2419	2419	2419
Max.		2140	1883	1254	924	3091	2719	1817	1339	4096	3605	2486	1832	5186	4564	3331	2454	7622	6708	4835	3563	10078	8559	6697	4934	12880	10648	8758	6453
H _f		3.54																											
H		21.97	21.97	21.97	21.97	24.02	24.02	24.02	24.02	27.17	27.17	27.17	27.17	32.48	32.48	32.48	32.48	37.20	37.20	37.20	37.20	41.14	41.14	41.14	41.14	41.14	41.14	41.14	41.14
W		27.95	38.62	38.62	38.62	44.21	44.21	44.21	44.21	46.77	46.77	46.77	46.77	53.50	53.50	53.50	53.50	59.06	59.06	59.06	59.06	66.14	66.14	66.14	66.14	66.14	66.14	66.14	66.14
W _i		24.02	34.68	34.68	34.68	40.28	40.28	40.28	40.28	42.83	42.83	42.83	42.83	49.57	49.57	49.57	49.57	55.12	55.12	55.12	55.12	62.20	62.20	62.20	62.20	62.20	62.20	62.20	62.20
H _i		14.49	14.49	14.49	14.49	16.54	16.54	16.54	16.54	19.69	19.69	19.69	19.69	25.00	25.00	25.00	25.00	29.72	29.72	29.72	29.72	33.66	33.66	33.66	33.66	33.66	33.66	33.66	33.66

Main configuration	DE*	Basic configurations						
AVS-XXX-R-V	-	44.26	44.26	44.26	44.26	58.65	58.65	73.05
AVS-XXX-R-FV	-	58.65	58.65	58.65	58.65	73.05	73.05	87.45
AVS-XXX-R-FHV	-	73.05	73.05	73.05	73.05	87.45	87.45	101.85
AVS-XXX-R-FCV	-	73.05	73.05	73.05	73.05	87.45	87.45	101.85
AVS-XXX-R-FCV	✓	87.45	87.45	87.45	87.45	87.45	87.45	101.85
AVS-XXX-R-FHCV	-	87.45	87.45	87.45	87.45	101.85	101.85	116.24
AVS-XXX-R-FHCV	✓	101.85	101.85	101.85	101.85	101.85	101.85	116.24
AVS-XXX-R-FHCV	-	101.85	101.85	101.85	101.85	116.24	116.24	130.64
AVS-XXX-R-FHCV	✓	116.24	116.24	116.24	116.24	116.24	116.24	130.64
AVS-XXX-R-FGHV	-	87.45	87.45	87.45	87.45	101.85	101.85	116.24
AVS-XXX-R-FGV	-	73.05	73.05	73.05	73.05	87.45	87.45	101.85
AVS-XXX-R-FGV	-	101.85	101.85	101.85	101.85	116.24	116.24	130.64
AVS-XXX-R-FGCVH	✓	116.24	116.24	116.24	116.24	116.24	116.24	130.64

Units with external filters instead of internal are shorter by 14.4 inches

		Additional functions						
Empty section	L _{min}	29.86	29.86	29.86	29.86	29.86	29.86	29.86
	L _{max}	29.86	29.86	29.86	29.86	29.86	29.86	29.86
Mixing box	L	29.86	29.86	29.86	29.86	29.86	29.86	29.86

* Include Droplet Eliminator after Cooling Coil



DIMENSIONS - AVS 8-55 - SUPPLY & EXHAUST

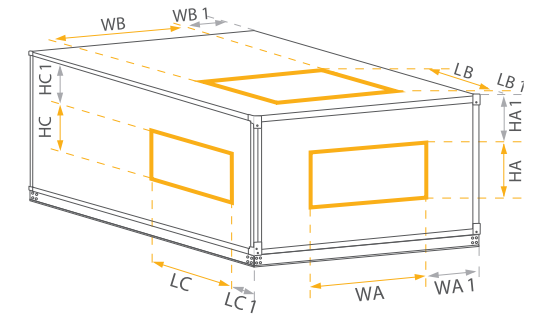
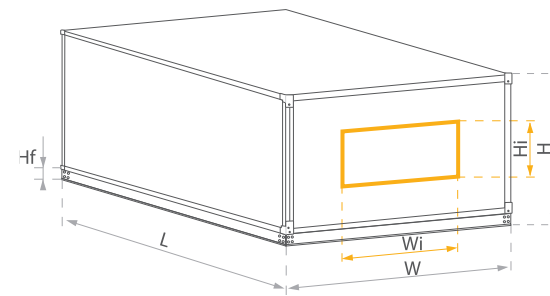

AIR INLET / DISCHARGE DIMENSIONS

END FULL (FF)				
UNIT	WA	HA	WA1	HA1
AVS 008	21.65	12.13	3.15	3.15
AVS 012	32.32	12.13	3.15	3.15
AVS 016	37.91	14.17	3.15	3.15
AVS 020	40.47	17.32	3.15	3.15
AVS 030	47.20	22.64	3.15	3.15
AVS 040	52.76	27.36	3.15	3.15
AVS 055	59.84	31.30	3.15	3.15

END (FS)				
UNIT	WA	HA	WA1	HA1
AVS 008	17.99	7.99	5.03	5.23
AVS 012	25.98	7.99	6.33	5.23
AVS 016	34.02	7.99	5.13	6.23
AVS 020	25.98	12.01	10.43	5.83
AVS 030	34.02	12.01	9.83	8.53
AVS 040	40.47	17.32	9.29	8.19
AVS 055	47.20	22.64	9.47	7.48

Top (US)				
UNIT	WB	LB	WB1	LB1
AVS 008	17.99	7.99	5.03	4.33
AVS 012	25.98	7.99	6.33	4.33
AVS 016	34.02	7.99	5.13	4.33
AVS 020	25.98	12.01	10.43	4.33
AVS 030	34.02	12.01	9.83	4.33
AVS 040	40.47	17.32	9.29	8.27
AVS 055	47.20	22.64	9.47	5.31

Top (US)				
UNIT	WB	LB	WB1	LB1
AVS 008	17.94	7.94	5.00	11.46
AVS 012	25.94	7.94	6.34	11.46
AVS 016	33.94	7.94	5.16	11.46
AVS 020	25.94	11.94	10.43	9.46
AVS 030	33.94	11.94	9.80	9.46
AVS 040	47.20	22.64	5.93	8.66
AVS 055	52.76	27.36	6.69	8.66

UNIT CODING

AVS - XXX - R/L - EM / HC / EM

AVS - type of AHU family
 XXX - size of unit (equal to the rated air flow in cfm)
 R/L - inspection side (R- right, L-left)
 EM - symbols of additional functions upstream main functions
 HC - symbols of main thermodynamic functions (basic functions)
 EM - symbols of additional functions downstream main functions
 Length depends on AHU equipment

Side (BS)				
UNIT	HC	LC	HC1	LC1
AVS 008	10.94	7.94	4.33	3.74
AVS 012	10.94	7.94	4.33	3.74
AVS 016	12.94	7.94	4.33	3.74
AVS 020	15.94	11.94	4.33	3.82
AVS 030	20.94	11.94	4.33	3.98
AVS 040	16.26	14.96	6.89	8.70
AVS 055	24.13	14.96	6.89	6.73



AVS 65-380 - SUPPLY & EXHAUST

Rated parameters		Recommended range of airflow																															
Size		AVS065		AVS085		AVS100		AVS130		AVS170		AVS230		AVS300		AVS380																	
75 000	[CFM]	[Bar chart showing airflow ranges for each unit size]																															
50 000		[Bar chart showing airflow ranges for each unit size]																															
25 000		[Bar chart showing airflow ranges for each unit size]																															
0		[Bar chart showing airflow ranges for each unit size]																															
Min.		2 995	3 307	3 307	3 307	2 952	4 069	4 069	4 069	3 559	4 501	4 501	4 501	4 283	4 979	5 183	5 183	5 557	7 630	7 630	7 706	10 427	10 427	10 427	8 988	12 165	12 165	12 165	11 834	15 526	15 526	15 526	
Max.		15 402	14 553	10 640	7 840	18 983	17 907	13 199	9 725	22 883	19 807	16 026	11 809	27 540	21 909	19 697	14 513	35 731	33 576	26 348	19 414	49 540	45 883	35 609	26 238	57 783	53 531	43 761	32 245	76 080	68 316	58 255	42 924
H _f		3.54								3.15																							
H		42.60		46.57		54.21		54.21		65.98		75.16		75.16		93.94																	
W		75.24		82.87		82.87		98.94		102.56		122.24		141.93		146.34																	
W _i		71.30		78.94		78.94		95.00		98.62		118.31		137.99		142.40																	
H _i		35.12		39.09		47.13		47.13		58.90		68.07		68.07		86.85																	

Main configuration	DE*	Basic configurations							
	-	73.05	73.05	58.65	58.65	73.05	73.05	73.05	73.05
	-	87.45	87.45	73.05	73.05	87.45	87.45	87.45	87.45
	-	101.85	101.85	87.45	87.45	101.85	101.85	101.85	101.85
	-	101.85	101.85	87.45	87.45	101.85	101.85	101.85	101.85
	✓	101.85	101.85	87.45	87.45	101.85	101.85	101.85	101.85
	-	116.24	116.24	101.85	101.85	116.24	116.24	116.24	116.24
	✓	116.24	116.24	101.85	101.85	116.24	116.24	116.24	116.24
	-	130.64	130.64	116.24	116.24	130.64	130.64	130.64	130.64
	✓	130.64	130.64	116.24	116.24	130.64	130.64	130.64	130.64
	-	116.24	116.24	101.85	101.85	116.24	116.24	116.24	116.24
	-	101.85	101.85	87.45	87.45	101.85	101.85	101.85	101.85
	✓	130.64	130.64	116.24	116.24	130.64	130.64	130.64	130.64
	-	130.64	130.64	116.24	116.24	130.64	130.64	130.64	130.64
	✓	130.64	130.64	116.24	116.24	130.64	130.64	130.64	130.64

Units with external filters instead of internal are shorter by 14.4 inches

		Additional functions							
Empty section	L _{min}	29.86	29.86	29.86	29.86	29.86	29.86	29.86	29.86
	L _{max}	29.86	44.26	44.26	44.26	44.26	44.26	44.26	44.26
Mixing box	L	29.86	44.26	44.26	44.26	44.26	44.26	44.26	44.26

* Include Droplet Eliminator after Cooling Coil



DIMENSIONS - AVS 65-380 - SUPPLY & EXHAUST

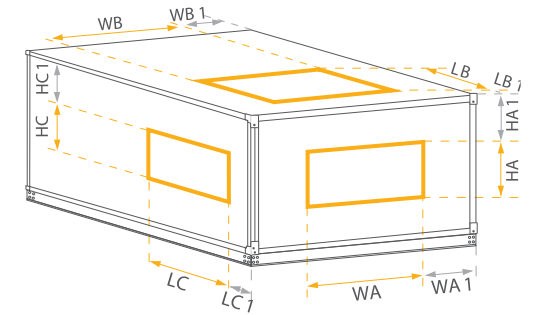
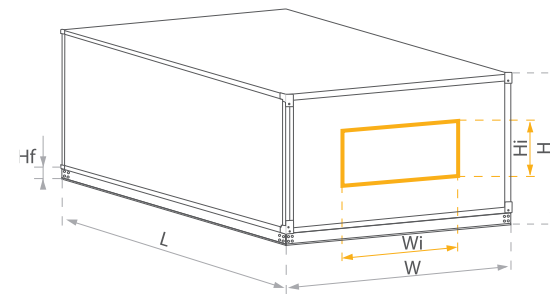

AIR INLET / DISCHARGE DIMENSIONS

END FULL (FF)					
UNIT	WA	HA	WA1	HA1	
AVS 065	68.94	32.76	3.15	3.15	
AVS 085	76.57	36.73	3.15	3.15	
AVS 100	76.57	44.76	3.15	3.15	
AVS 130	92.64	44.76	3.15	3.15	
AVS 170	96.26	56.54	3.15	3.15	
AVS 230	115.94	65.71	3.15	3.15	
AVS 300	135.63	65.71	3.15	3.15	
AVS 380	140.04	84.49	3.15	3.15	

END (FS)					
UNIT	WA	HA	WA1	HA1	
AVS 065	47.20	22.64	14.02	8.23	
AVS 085	59.84	31.30	11.52	5.87	
AVS 100	59.84	31.30	11.52	9.88	
AVS 130	76.57	36.73	11.18	7.17	
AVS 170	76.57	36.73	12.99	13.07	
AVS 230	104.33	36.73	8.96	17.64	
AVS 300	124.02	36.73	8.96	17.64	
AVS 380	127.95	36.73	9.19	27.05	

Top (US)					
UNIT	WB	LB	WB1	LB1	
AVS 065	47.20	22.64	14.02	5.31	
AVS 085	59.84	31.30	11.52	8.27	
AVS 100	59.84	31.30	11.52	8.27	
AVS 130	76.57	36.73	11.18	5.31	
AVS 170	76.57	36.73	12.99	5.31	
AVS 230	104.33	36.73	8.96	5.31	
AVS 300	124.02	36.73	8.96	5.31	
AVS 380	127.95	36.73	9.19	5.31	

Top (US)					
UNIT	WB	LB	WB1	LB1	
AVS 065	59.84	31.30	7.70	5.31	
AVS 085	59.84	31.30	11.52	5.31	
AVS 100	59.84	31.30	11.52	5.31	
AVS 130	75.31	29.13	11.81	5.31	
AVS 170	76.57	36.73	12.99	5.31	
AVS 230	104.33	36.73	8.96	5.31	
AVS 300	124.02	36.73	8.96	8.66	
AVS 380	127.95	36.73	9.19	8.66	

UNIT CODING

AVS - XXX - R/L - EM / HC / EM

AVS - type of AHU family
 XXX - size of unit (equal to the rated air flow in cfm)
 R/L - inspection side (R- right, L-left)
 EM - symbols of additional functions upstream main functions
 HC - symbols of main thermodynamic functions (basic functions)
 EM - symbols of additional functions downstream main functions
 Length depends on AHU equipment

Side (BS)					
UNIT	HC	LC	HC1	LC1	
AVS 065	24.13	14.96	6.89	7.46	
AVS 085	28.07	29.13	6.89	7.48	
AVS 100	35.94	29.13	6.89	7.56	
AVS 130	35.94	29.13	6.89	7.56	
AVS 170	47.76	29.13	6.89	7.54	
AVS 230	59.57	29.13	6.89	6.22	
AVS 300	59.57	29.13	6.89	6.22	
AVS 380	75.31	29.13	6.89	7.74	



AVS 8-55 - CROSS-FLOW PLATE

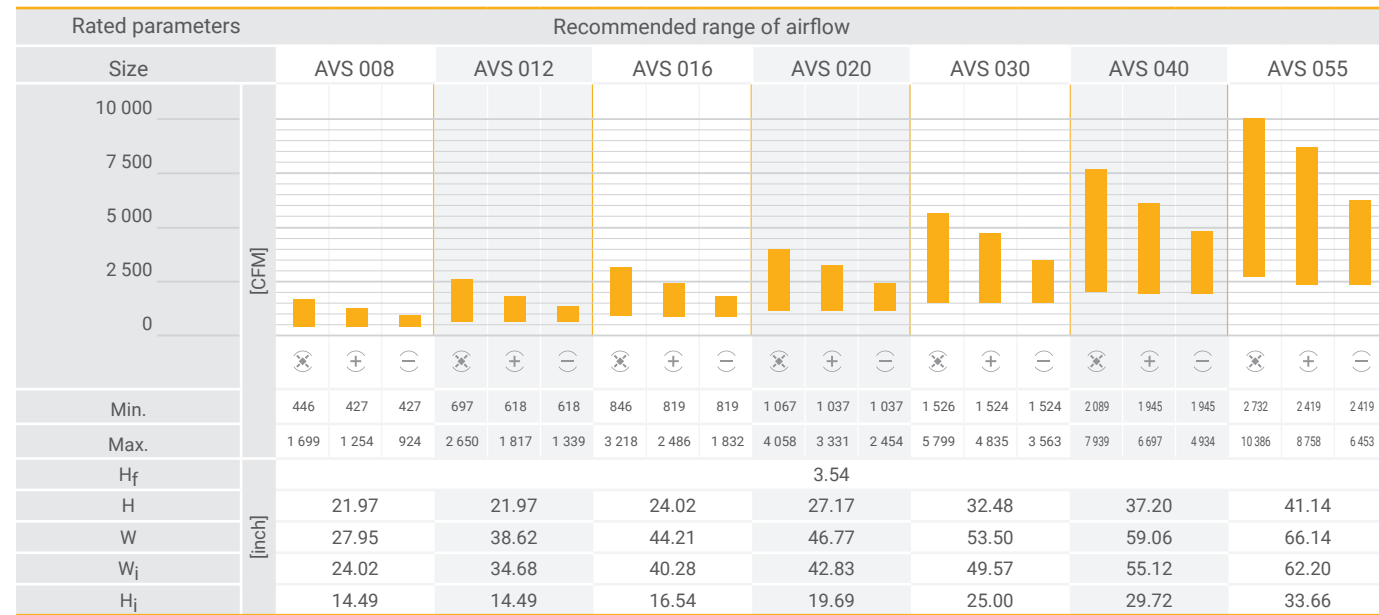

Min.	446	427	427	697	618	618	846	819	819	1 067	1 037	1 037	1 526	1 524	1 524	2 089	1 945	1 945	2 732	2 419	2 419
Max.	1 699	1 254	924	2 650	1 817	1 339	3 218	2 486	1 832	4 058	3 331	2 454	5 799	4 835	3 563	7 939	6 697	4 934	10 386	8 758	6 453

H _f	3.54																				
H	21.97																				
W	27.95																				
W _i	24.02																				
H _i	14.49																				

Main configuration DE*		Basic configurations						
	L2	116.24	116.24	116.24	116.24	145.04	145.04	173.83
	L1	101.85	101.85	101.85	101.85	130.64	130.64	159.44
	L2	101.85	101.85	101.85	101.85	130.64	130.64	159.44
	L1	116.24	116.24	116.24	116.24	145.04	145.04	173.83
	L2	101.85	101.85	101.85	116.24	130.64	145.04	173.83
	L1	101.85	101.85	101.85	101.85	130.64	130.64	159.44
	L2	101.85	101.85	101.85	101.85	130.64	130.64	159.44
	L1	116.24	116.24	116.24	130.64	145.04	159.44	188.23
	L2	116.24	116.24	116.24	116.24	145.04	145.04	173.83
	L1	116.24	116.24	116.24	116.24	145.04	145.04	173.83
	L2	116.24	116.24	116.24	116.24	145.04	145.04	173.83
	L1	116.24	116.24	116.24	116.24	145.04	145.04	173.83
	L2	101.85	101.85	101.85	116.24	130.64	145.04	173.83
	L1	116.24	116.24	116.24	116.24	145.04	145.04	173.83
	L2	116.24	116.24	116.24	116.24	145.04	145.04	173.83
	L1	101.85	101.85	101.85	116.24	130.64	145.04	173.83
	L2	116.24	116.24	116.24	116.24	145.04	145.04	173.83
	L1	116.24	116.24	116.24	116.24	145.04	145.04	173.83
	L2	116.24	116.24	116.24	116.24	145.04	145.04	173.83
	L1	116.24	116.24	116.24	116.24	145.04	145.04	173.83

* Include Droplet Eliminator after Cooling Coil

L1- doesn't cover empty space in bottom deck

Main configuration DE*		Basic configurations						
	L2	116.24	116.24	116.24	116.24	145.04	145.04	173.83
	L1	116.24	116.24	116.24	116.24	145.04	145.04	173.83
	L2	116.24	116.24	116.24	116.24	145.04	145.04	173.83
	L1	130.64	130.64	130.64	130.64	145.04	145.04	173.83
	L2	116.24	116.24	116.24	116.24	145.04	145.04	173.83
	L1	116.24	116.24	116.24	116.24	145.04	145.04	173.83
	L2	101.85	101.85	101.85	116.24	130.64	145.04	173.83
	L1	116.24	116.24	116.24	116.24	145.04	145.04	173.83
	L2	116.24	116.24	116.24	116.24	145.04	145.04	173.83
	L1	101.85	101.85	101.85	116.24	130.64	145.04	173.83
	L2	116.24	116.24	116.24	116.24	145.04	145.04	173.83
	L1	101.85	101.85	101.85	116.24	130.64	145.04	173.83
	L2	116.24	116.24	116.24	116.24	145.04	145.04	173.83
	L1	116.24	116.24	116.24	116.24	145.04	145.04	173.83
	L2	101.85	101.85	101.85	116.24	130.64	145.04	173.83
	L1	130.64	130.64	130.64	130.64	145.04	145.04	173.83
	L2	116.24	116.24	116.24	116.24	145.04	145.04	173.83
	L1	116.24	116.24	116.24	116.24	145.04	145.04	173.83
	L2	116.24	116.24	116.24	116.24	145.04	145.04	173.83
	L1	101.85	101.85	101.85	116.24	130.64	145.04	173.83
	L2	116.24	116.24	116.24	116.24	145.04	145.04	173.83
	L1	116.24	116.24	116.24	116.24	145.04	145.04	173.83
	L2	116.24	116.24	116.24	116.24	145.04	145.04	173.83
	L1	116.24	116.24	116.24	116.24	145.04	145.04	173.83

* Include Droplet Eliminator after Cooling Coil

L1- doesn't cover empty space in bottom deck



Main configuration DE*		Basic configurations						
	L2	101.85	101.85	101.85	116.24	130.64	145.04	173.83
	L1	130.64	130.64	130.64	130.64	159.44	159.44	188.23
	L2	101.85	101.85	101.85	116.24	130.64	145.04	173.83
	L1	145.04	145.04	145.04	145.04	159.44	159.44	188.23
	L2	116.24	116.24	116.24	116.24	145.04	145.04	173.83
	L1	130.64	130.64	130.64	130.64	159.44	159.44	188.23
	L2	116.24	116.24	116.24	116.24	145.04	145.04	173.83
	L1	145.04	145.04	145.04	145.04	159.44	159.44	188.23
	L2	101.85	101.85	101.85	116.24	130.64	145.04	173.83
	L1	130.64	130.64	130.64	130.64	159.44	159.44	188.23
	L2	101.85	101.85	101.85	116.24	130.64	145.04	173.83
	L1	145.04	145.04	145.04	145.04	159.44	159.44	188.23
	L2	116.24	116.24	116.24	116.24	145.04	145.04	173.83
	L1	130.64	130.64	130.64	130.64	159.44	159.44	188.23
	L2	116.24	116.24	116.24	116.24	145.04	145.04	173.83
	L1	145.04	145.04	145.04	145.04	159.44	159.44	188.23
	L2	101.85	101.85	101.85	116.24	130.64	145.04	173.83
	L1	130.64	130.64	130.64	130.64	159.44	159.44	188.23
	L2	101.85	101.85	101.85	116.24	130.64	145.04	173.83
	L1	145.04	145.04	145.04	145.04	159.44	159.44	188.23
	L2	116.24	116.24	116.24	116.24	145.04	145.04	173.83
	L1	130.64	130.64	130.64	130.64	159.44	159.44	188.23
	L2	116.24	116.24	116.24	116.24	145.04	145.04	173.83
	L1	145.04	145.04	145.04	145.04	159.44	159.44	188.23

* Include Droplet Eliminator after Cooling Coil

L1- doesn't cover empty space in bottom deck

Main configuration DE*		Basic configurations						
	L2	116.24	116.24	116.24	116.24	145.04	145.04	173.83
	L1	130.64	130.64	130.64	130.64	159.44	159.44	188.23
	L2	116.24	116.24	116.24	116.24	145.04	145.04	173.83
	L1	145.04	145.04	145.04	145.04	159.44	159.44	188.23
	L2	116.24	116.24	116.24	116.24	145.04	145.04	173.83
	L1	145.04	145.04	145.04	145.04	173.83	173.83	202.63
	L2	116.24	116.24	116.24	116.24	145.04	145.04	173.83
	L1	159.44	159.44	159.44	159.44	173.83	173.83	202.63
	L2	145.04	145.04	145.04	145.04	173.83	173.83	202.63
	L1	116.24	116.24	116.24	116.24	145.04	145.04	173.83
	L2	116.24	116.24	116.24	130.64	145.04	159.44	188.23
	L1	145.04	145.04	145.04	145.04	173.83	173.83	202.63
	L2	116.24	116.24	116.24	130.64	145.04	159.44	188.23
	L1	159.44	159.44	159.44	159.44	173.83	173.83	202.63
	L2	145.04	145.04	145.04	145.04	173.83	173.83	202.63
	L1	116.24	116.24	116.24	130.64	145.04	159.44	188.23
	L2	159.44	159.44	159.44	159.44	173.83	173.83	202.63
	L1	116.24	116.24	116.24	130.64	145.04	159.44	188.23
	L2	116.24	116.24	116.24	116.24	145.04	145.04	173.83
	L1	159.44	159.44	159.44	159.44	173.83	173.83	202.63
	L2	145.04	145.04	145.04	145.04	173.83	173.83	202.63
	L1	116.24	116.24	116.24	116.24	145.04	145.04	173.83
	L2	159.44	159.44	159.44	159.44	173.83	173.83	202.63
	L1	116.24	116.24	116.24	116.24	145.04	145.04	173.83

* Include Droplet Eliminator after Cooling Coil

L1- doesn't cover empty space in bottom deck



AVS 65-380 - CROSS-FLOW PLATE

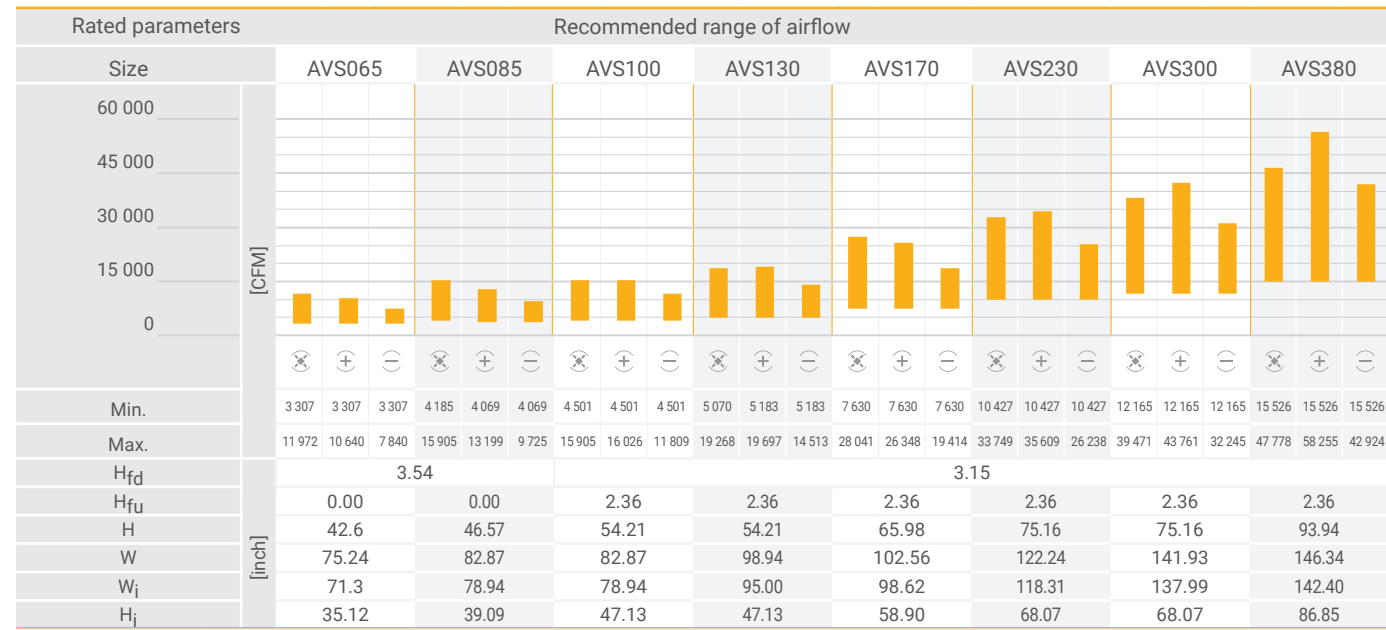

Main configuration DE*		Basic configurations												
Diagram	L [inch]	AVS065	AVS085	AVS100	AVS130	AVS170	AVS230	AVS300	AVS380					
	L2	173.83	188.23	173.83	173.83	217.03	217.03	217.03	231.42					
	L1	159.44	173.83	159.44	159.44	202.63	202.63	202.63	217.03					
	L2	159.44	173.83	159.44	159.44	202.63	202.63	202.63	217.03					
	L1	173.83	188.23	173.83	173.83	217.03	217.03	217.03	231.42					
	L2	173.83	173.83	159.44	159.44	202.63	202.63	202.63	217.03					
	L1	159.44	173.83	159.44	159.44	202.63	202.63	202.63	217.03					
	L2	159.44	173.83	159.44	159.44	202.63	202.63	202.63	217.03					
	L1	188.23	188.23	173.83	173.83	217.03	217.03	217.03	231.42					
	L2	173.83	188.23	173.83	173.83	217.03	217.03	217.03	231.42					
	L1	173.83	188.23	173.83	173.83	217.03	217.03	217.03	231.42					
	L2	173.83	188.23	173.83	173.83	217.03	217.03	217.03	231.42					
	L1	173.83	188.23	173.83	173.83	217.03	217.03	217.03	231.42					
	L2	173.83	173.83	159.44	159.44	202.63	202.63	202.63	217.03					
	L1	173.83	188.23	173.83	173.83	217.03	217.03	217.03	231.42					
	L2	173.83	188.23	173.83	173.83	217.03	217.03	217.03	231.42					
	L1	173.83	173.83	159.44	159.44	202.63	202.63	202.63	217.03					
	L2	173.83	188.23	173.83	173.83	217.03	217.03	217.03	231.42					
	L1	173.83	188.23	173.83	173.83	217.03	217.03	217.03	231.42					
	L2	173.83	188.23	173.83	173.83	217.03	217.03	217.03	231.42					
	L1	173.83	188.23	173.83	173.83	217.03	217.03	217.03	231.42					

* Include Droplet Eliminator after Cooling Coil

L1- doesn't cover empty space in bottom deck

Main configuration DE*		Basic configurations												
Diagram	L [inch]	AVS065	AVS085	AVS100	AVS130	AVS170	AVS230	AVS300	AVS380					
	L2	173.83	188.23	173.83	173.83	217.03	217.03	217.03	231.42					
	L1	173.83	188.23	173.83	173.83	217.03	217.03	217.03	231.42					
	L2	173.83	188.23	173.83	173.83	217.03	217.03	217.03	231.42					
	L1	173.83	188.23	173.83	173.83	217.03	217.03	217.03	231.42					
	L2	173.83	173.83	159.44	159.44	202.63	202.63	202.63	217.03					
	L1	173.83	188.23	173.83	173.83	217.03	217.03	217.03	231.42					
	L2	173.83	173.83	159.44	159.44	202.63	202.63	202.63	217.03					
	L1	173.83	188.23	173.83	173.83	217.03	217.03	217.03	231.42					
	L2	173.83	188.23	173.83	173.83	217.03	217.03	217.03	231.42					
	L1	173.83	188.23	173.83	173.83	217.03	217.03	217.03	231.42					
	L2	173.83	188.23	173.83	173.83	217.03	217.03	217.03	231.42					
	L1	173.83	188.23	173.83	173.83	217.03	217.03	217.03	231.42					
	L2	173.83	188.23	173.83	173.83	217.03	217.03	217.03	231.42					
	L1	188.23	202.63	188.23	188.23	231.42	231.42	231.42	245.82					
	L2	173.83	188.23	173.83	173.83	217.03	217.03	217.03	231.42					
	L1	188.23	202.63	188.23	188.23	231.42	231.42	231.42	245.82					
	L2	188.23	202.63	188.23	188.23	231.42	231.42	231.42	245.82					
	L1	173.83	188.23	173.83	173.83	217.03	217.03	217.03	231.42					
	L2	188.23	202.63	188.23	188.23	231.42	231.42	231.42	245.82					
	L1	173.83	188.23	173.83	173.83	217.03	217.03	217.03	231.42					

* Include Droplet Eliminator after Cooling Coil

L1- doesn't cover empty space in bottom deck



Main configuration DE*		Basic configurations							
	L2	173.83	173.83	159.44	159.44	202.63	202.63	202.63	217.03
	L1	188.23	202.63	188.23	188.23	231.42	231.42	231.42	245.82
	L2	173.83	173.83	159.44	159.44	202.63	202.63	202.63	217.03
	L1	188.23	202.63	188.23	188.23	231.42	231.42	231.42	245.82
	L2	173.83	188.23	173.83	173.83	217.03	217.03	217.03	231.42
	L1	188.23	202.63	188.23	188.23	231.42	231.42	231.42	245.82
	L2	173.83	188.23	173.83	173.83	217.03	217.03	217.03	231.42
	L1	188.23	202.63	188.23	188.23	231.42	231.42	231.42	245.82
	L2	173.83	173.83	159.44	159.44	202.63	202.63	202.63	217.03
	L1	188.23	202.63	188.23	188.23	231.42	231.42	231.42	245.82
	L2	173.83	173.83	159.44	159.44	202.63	202.63	202.63	217.03
	L1	188.23	202.63	188.23	188.23	231.42	231.42	231.42	245.82
	L2	173.83	188.23	173.83	173.83	217.03	217.03	217.03	231.42
	L1	188.23	202.63	188.23	188.23	231.42	231.42	231.42	245.82
	L2	173.83	188.23	173.83	173.83	217.03	217.03	217.03	231.42
	L1	188.23	202.63	188.23	188.23	231.42	231.42	231.42	245.82

* Include Droplet Eliminator after Cooling Coil

L1- doesn't cover empty space in bottom deck

Main configuration DE*		Basic configurations							
	L2	173.83	188.23	173.83	173.83	217.03	217.03	217.03	231.42
	L1	188.23	202.63	188.23	188.23	231.42	231.42	231.42	245.82
	L2	173.83	188.23	173.83	173.83	217.03	217.03	217.03	231.42
	L1	188.23	202.63	188.23	188.23	231.42	231.42	231.42	245.82
	L2	173.83	188.23	173.83	173.83	217.03	217.03	217.03	231.42
	L1	188.23	202.63	188.23	188.23	231.42	231.42	231.42	245.82
	L2	173.83	188.23	173.83	173.83	217.03	217.03	217.03	231.42
	L1	188.23	202.63	188.23	188.23	231.42	231.42	231.42	245.82
	L2	173.83	188.23	173.83	173.83	217.03	217.03	217.03	231.42
	L1	188.23	202.63	188.23	188.23	231.42	231.42	231.42	245.82
	L2	173.83	188.23	173.83	173.83	217.03	217.03	217.03	231.42
	L1	188.23	202.63	188.23	188.23	231.42	231.42	231.42	245.82

* Include Droplet Eliminator after Cooling Coil

L1- doesn't cover empty space in bottom deck



DIMENSIONS - AVS 8-55 - CROSS-FLOW PLATE

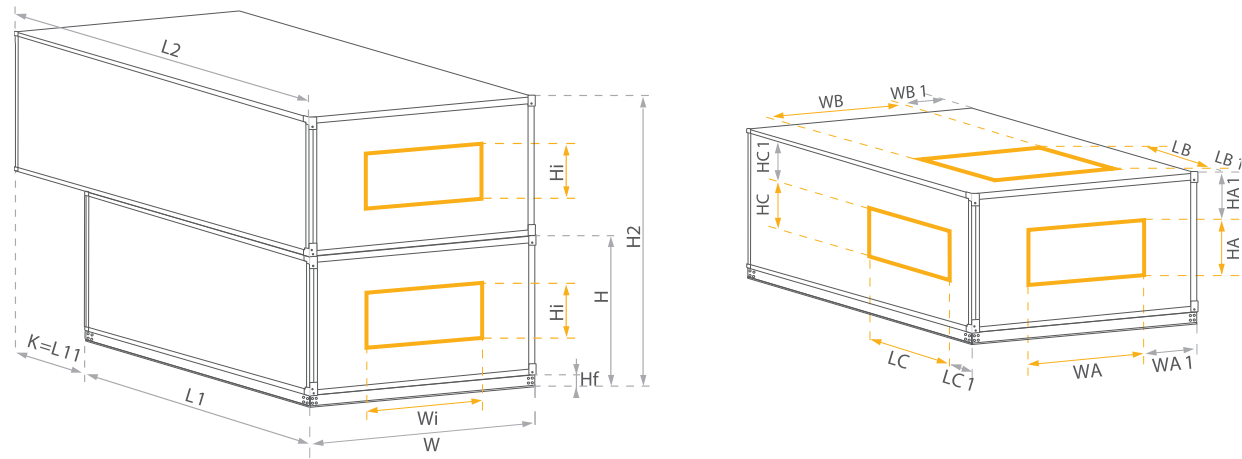

AIR INLET / DISCHARGE DIMENSIONS

END FULL (FF)					END (FS)				
UNIT	WA	HA	WA1	HA1	UNIT	WA	HA	WA1	HA1
AVS 008	21.65	12.13	3.15	3.15	AVS 008	17.97	7.97	5.00	5.24
AVS 012	32.32	12.13	3.15	3.15	AVS 012	25.97	7.97	6.34	5.24
AVS 016	37.91	14.17	3.15	3.15	AVS 016	33.97	7.97	5.16	6.26
AVS 020	40.47	17.32	3.15	3.15	AVS 020	25.97	11.97	10.43	5.83
AVS 030	47.20	22.64	3.15	3.15	AVS 030	33.97	11.97	9.80	8.50
AVS 040	52.76	27.36	3.15	3.15	AVS 040	40.51	17.36	9.29	8.19
AVS 055	59.84	31.30	3.15	3.15	AVS 055	47.24	22.68	9.47	7.48

Side (BS)				
UNIT	HC	LC	HC1	LC1
AVS 008	10.94	7.94	4.33	3.74
AVS 012	10.94	7.94	4.33	3.74
AVS 016	12.94	7.94	4.33	3.74
AVS 020	15.94	11.94	4.33	3.82
AVS 030	20.94	11.94	4.33	3.98
AVS 040	16.26	14.96	6.89	8.70
AVS 055	24.13	14.96	6.89	6.73

UNIT CODING

AVS - XX

AVS - type of AHU family
 XXX - size of unit (equal to the rated air flow in cfm*0.001)
 R/L - inspection side (R- right, L -left)
 PHC - symbols of main thermodynamic functions (basic functions)
 Length depends on AHU equipment



DIMENSIONS - AVS 65-380 - CROSS-FLOW PLATE

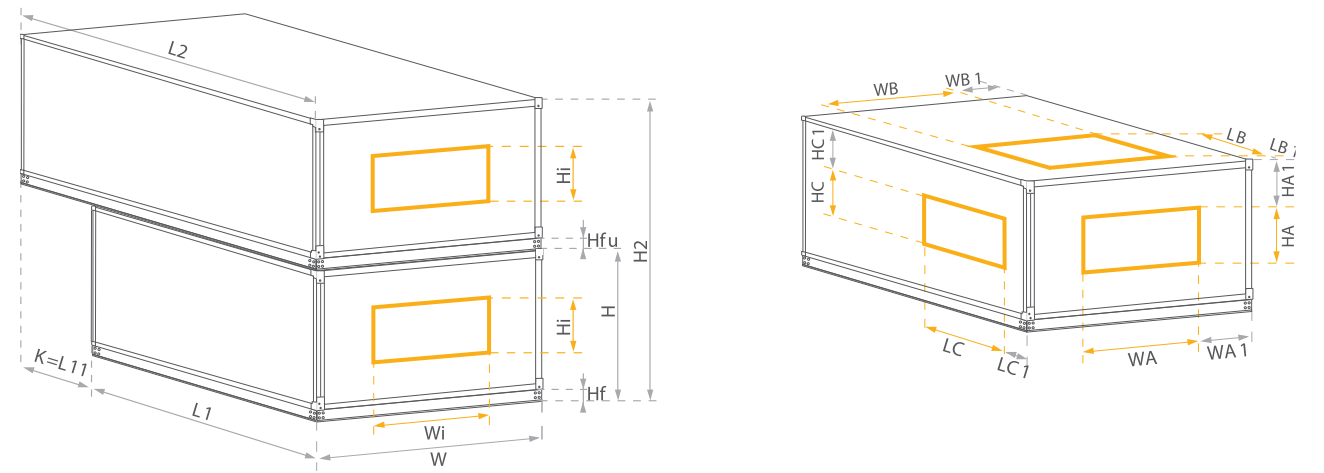

AIR INLET / DISCHARGE DIMENSIONS

END FULL (FF)					END (FS)				
UNIT	WA	HA	WA1	HA1	UNIT	WA	HA	WA1	HA1
AVS 065	68.94	32.76	3.15	3.15	AVS 065	47.24	22.68	14.02	8.23
AVS 085	76.57	36.73	3.15	3.15	AVS 085	59.88	31.34	11.52	5.87
AVS 100	76.57	44.76	3.15	3.15	AVS 100	59.88	31.34	11.52	9.88
AVS 130	92.64	44.76	3.15	3.15	AVS 130	76.61	36.77	11.18	7.17
AVS 170	96.26	56.54	3.15	3.15	AVS 170	76.61	36.77	12.99	13.07
AVS 230	115.94	65.71	3.15	3.15	AVS 230	104.37	36.77	8.96	17.64
AVS 300	135.63	65.71	3.15	3.15	AVS 300	124.06	36.77	8.96	17.64
AVS 300	140.04	84.49	3.15	3.15	AVS 380	127.99	36.77	9.19	27.05

Side (BS)				
UNIT	HC	LC	HC1	LC1
AVS 065	24.13	14.96	6.89	7.46
AVS 085	28.07	29.13	6.89	7.48
AVS 100	35.94	29.13	6.89	7.56
AVS 130	35.94	29.13	6.89	7.56
AVS 170	47.76	29.13	6.89	7.54
AVS 230	59.57	29.13	6.89	6.22
AVS 300	59.57	29.13	6.89	6.22
AVS 380	75.31	29.13	6.89	7.74

UNIT CODING

AVS - XX

AVS - type of AHU family
 XXX - size of unit (equal to the rated air flow in cfm*0.001)
 R/L - inspection side (R- right, L -left)
 PHC - symbols of main thermodynamic functions (basic functions)
 Length depends on AHU equipment



AVS 12 - 65 WITH ENERGY WHEEL

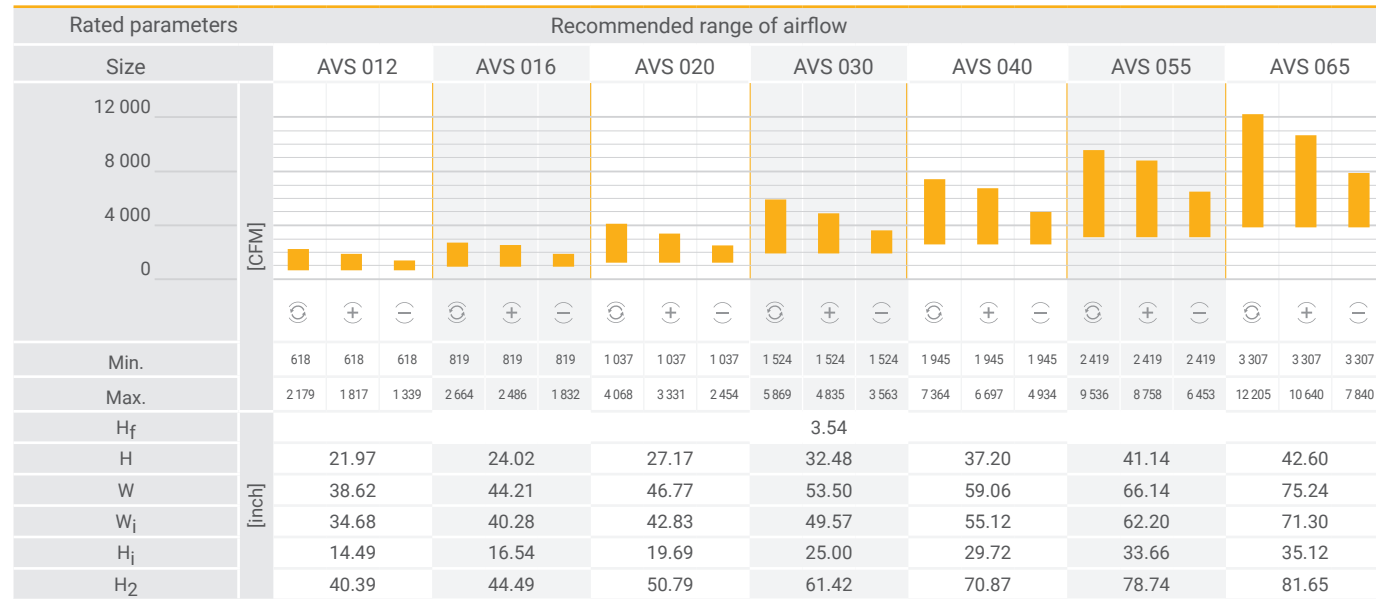

Main configuration DE*		Basic configurations						
[Diagram]	L2	87.45	87.45	87.45	101.85	101.85	116.24	116.24
[Diagram]	L1	87.45	87.45	87.45	101.85	101.85	116.24	116.24
[Diagram]	L11	28.80	28.80	28.80	43.19	43.19	57.59	57.59
[Diagram]	L2	87.45	87.45	87.45	101.85	101.85	116.24	116.24
[Diagram]	L1	87.45	87.45	87.45	101.85	101.85	116.24	116.24
[Diagram]	L11	28.80	28.80	28.80	43.19	43.19	57.59	57.59
[Diagram]	L2	87.45	87.45	87.45	101.85	101.85	116.24	116.24
[Diagram]	L1	101.85	101.85	101.85	116.24	116.24	130.64	130.64
[Diagram]	L11	28.80	28.80	28.80	43.19	43.19	57.59	57.59
[Diagram]	L2	101.85	101.85	101.85	116.24	116.24	130.64	130.64
[Diagram]	L1	87.45	87.45	87.45	101.85	101.85	116.24	116.24
[Diagram]	L11	43.19	43.19	43.19	57.59	57.59	71.99	71.99
[Diagram]	L2	116.24	116.24	116.24	130.64	130.64	145.04	145.04
[Diagram]	L1	130.64	130.64	130.64	145.04	145.04	159.44	159.44
[Diagram]	L2	130.64	130.64	130.64	145.04	145.04	159.44	159.44
[Diagram]	L1	116.24	116.24	116.24	130.64	130.64	145.04	145.04
[Diagram]	L2	87.45	87.45	87.45	101.85	101.85	116.24	116.24
[Diagram]	L1	101.85	101.85	101.85	116.24	116.24	130.64	130.64
[Diagram]	L11	28.80	28.80	28.80	43.19	43.19	57.59	57.59
[Diagram]	L2	87.45	87.45	87.45	101.85	101.85	116.24	116.24
[Diagram]	L1	116.24	116.24	116.24	116.24	116.24	130.64	130.64
[Diagram]	L11	28.80	28.80	28.80	43.19	43.19	57.59	57.59
[Diagram]	L2	101.85	101.85	101.85	116.24	116.24	130.64	130.64
[Diagram]	L1	87.45	87.45	87.45	101.85	101.85	116.24	116.24
[Diagram]	L11	43.19	43.19	43.19	57.59	57.59	71.99	71.99
[Diagram]	L2	101.85	101.85	101.85	116.24	116.24	130.64	130.64
[Diagram]	L1	87.45	87.45	87.45	101.85	101.85	116.24	116.24
[Diagram]	L11	43.19	43.19	43.19	57.59	57.59	71.99	71.99
[Diagram]	L2	101.85	101.85	101.85	116.24	116.24	130.64	130.64
[Diagram]	L1	87.45	87.45	87.45	101.85	101.85	116.24	116.24
[Diagram]	L11	43.19	43.19	43.19	57.59	57.59	71.99	71.99

* Include Droplet Eliminator after Cooling Coil

L1- doesn't cover empty space in bottom deck

Main configuration DE*		Basic configurations						
[Diagram]	L2	116.24	116.24	116.24	130.64	130.64	145.04	145.04
[Diagram]	L1	130.64	130.64	130.64	145.04	145.04	159.44	159.44
[Diagram]	L2	116.24	116.24	116.24	130.64	130.64	145.04	145.04
[Diagram]	L1	145.04	145.04	145.04	145.04	145.04	159.44	159.44
[Diagram]	L2	130.64	130.64	130.64	145.04	145.04	159.44	159.44
[Diagram]	L1	116.24	116.24	116.24	130.64	130.64	145.04	145.04
[Diagram]	L2	101.85	101.85	101.85	116.24	116.24	130.64	130.64
[Diagram]	L1	145.04	145.04	145.04	159.44	159.44	173.83	173.83
[Diagram]	L11	28.80	28.80	28.80	43.19	43.19	57.59	57.59
[Diagram]	L2	101.85	101.85	101.85	116.24	116.24	130.64	130.64
[Diagram]	L1	159.44	159.44	159.44	159.44	159.44	173.83	173.83
[Diagram]	L11	28.80	28.80	28.80	43.19	43.19	57.59	57.59
[Diagram]	L2	145.04	145.04	145.04	159.44	159.44	173.83	173.83
[Diagram]	L1	101.85	101.85	101.85	116.24	116.24	130.64	130.64
[Diagram]	L11	57.59	57.59	57.59	71.99	71.99	86.39	86.39
[Diagram]	L2	145.04	145.04	145.04	159.44	159.44	173.83	173.83
[Diagram]	L1	101.85	101.85	101.85	116.24	116.24	130.64	130.64
[Diagram]	L11	57.59	57.59	57.59	71.99	71.99	86.39	86.39
[Diagram]	L2	87.45	87.45	87.45	101.85	101.85	116.24	116.24
[Diagram]	L1	116.24	116.24	116.24	130.64	130.64	145.04	145.04
[Diagram]	L11	28.80	28.80	28.80	43.19	43.19	57.59	57.59
[Diagram]	L2	87.45	87.45	87.45	101.85	101.85	116.24	116.24
[Diagram]	L1	130.64	130.64	130.64	130.64	130.64	145.04	145.04
[Diagram]	L11	28.80	28.80	28.80	43.19	43.19	57.59	57.59
[Diagram]	L2	116.24	116.24	116.24	130.64	130.64	145.04	145.04
[Diagram]	L1	87.45	87.45	87.45	101.85	101.85	116.24	116.24
[Diagram]	L11	57.59	57.59	57.59	71.99	71.99	86.39	86.39
[Diagram]	L2	116.24	116.24	116.24	130.64	130.64	145.04	145.04
[Diagram]	L1	145.04	145.04	145.04	159.44	159.44	173.83	173.83
[Diagram]	L11	57.59	57.59	57.59	71.99	71.99	86.39	86.39
[Diagram]	L2	116.24	116.24	116.24	130.64	130.64	145.04	145.04
[Diagram]	L1	145.04	145.04	145.04	159.44	159.44	173.83	173.83
[Diagram]	L11	14.40	14.40	14.40	14.40	14.40	14.40	14.40
[Diagram]	L2	145.04	145.04	145.04	159.44	159.44	173.83	173.83
[Diagram]	L1	116.24	116.24	116.24	130.64	130.64	145.04	145.04
[Diagram]	L11	14.40	14.40	14.40	14.40	14.40	14.40	14.40
[Diagram]	L2	116.24	116.24	116.24	130.64	130.64	145.04	145.04
[Diagram]	L1	145.04	145.04	145.04	159.44	159.44	173.83	173.83
[Diagram]	L11	14.40	14.40	14.40	14.40	14.40	14.40	14.40
[Diagram]	L2	145.04	145.04	145.04	159.44	159.44	173.83	173.83
[Diagram]	L1	116.24	116.24	116.24	130.64	130.64	145.04	145.04
[Diagram]	L11	14.40	14.40	14.40	14.40	14.40	14.40	14.40
[Diagram]	L2	145.04	145.04	145.04	159.44	159.44	173.83	173.83
[Diagram]	L1	116.24	116.24	116.24	130.64	130.64	145.04	145.04
[Diagram]	L11	14.40	14.40	14.40	14.40	14.40	14.40	14.40

* Include Droplet Eliminator after Cooling Coil

L1- doesn't cover empty space in bottom deck



AVS 85-380 WITH ENERGY WHEEL

Rated parameters		Recommended range of airflow																						
Size		AVS085			AVS100			AVS130			AVS170			AVS230			AVS300			AVS380				
60 000	[CFM]																							
40 000																								
20 000																								
0																								
Min.		4 069	4 069	4 069	4 501	4 501	4 501	4 979	5 183	5 183	7 630	7 630	7 630	10 427	10 427	10 427	12 165	12 165	12 165	15 526	15 526	15 526		
Max.		15 121	13 198	9 724	15 122	16 026	11 809	21 698	19 697	14 513	23 578	26 348	19 414	32 704	35 609	26 238	45 678	43 761	32 245	48 968	58 255	42 924		
H _{fd}		3.15																						
H _{fu}		0.00	2.36			2.36			2.36			2.36			2.36									
H		46.57	54.21			54.21			65.98			75.16			93.94									
W		82.87	82.87			98.94			102.56			122.24			141.93			146.34						
W _i		78.94	78.94			95.00			98.62			118.31			137.99			142.4						
H _i		39.09	47.13			47.13			58.9			68.07			68.07			86.85						
H ₂		89.61	107.64			107.64			131.18			149.53			149.53			187.09						

Main configuration DE*		Basic configurations						
	L2	116.24	101.85	101.85	116.24	116.24	116.24	116.24
	L1	116.24	101.85	101.85	116.24	116.24	116.24	116.24
	L11	57.59	43.19	43.19	57.59	57.59	57.59	57.59
	L2	116.24	101.85	101.85	116.24	116.24	116.24	116.24
	L1	116.24	101.85	101.85	116.24	116.24	116.24	116.24
	L11	57.59	43.19	43.19	57.59	57.59	57.59	57.59
	L2	116.24	101.85	101.85	116.24	116.24	116.24	116.24
	L1	130.64	116.24	116.24	130.64	130.64	130.64	130.64
	L11	57.59	43.19	43.19	57.59	57.59	57.59	57.59
	L2	130.64	116.24	116.24	130.64	130.64	130.64	130.64
	L1	116.24	101.85	101.85	116.24	116.24	116.24	116.24
	L11	71.99	57.59	57.59	71.99	71.99	71.99	71.99
	L2	159.44	145.04	145.04	159.44	159.44	159.44	159.44
	L1	173.83	159.44	159.44	173.83	173.83	173.83	173.83
	L11	173.83	159.44	159.44	173.83	173.83	173.83	173.83
	L2	116.24	101.85	101.85	116.24	116.24	116.24	116.24
	L1	130.64	116.24	116.24	130.64	130.64	130.64	130.64
	L11	57.59	43.19	43.19	57.59	57.59	57.59	57.59
	L2	116.24	101.85	101.85	116.24	116.24	116.24	116.24
	L1	130.64	116.24	116.24	130.64	130.64	130.64	130.64
	L11	57.59	43.19	43.19	57.59	57.59	57.59	57.59
	L2	116.24	101.85	101.85	116.24	116.24	116.24	116.24
	L1	116.24	101.85	101.85	116.24	116.24	116.24	116.24
	L11	71.99	57.59	57.59	71.99	71.99	71.99	71.99

* Include Droplet Eliminator after Cooling Coil

L1- doesn't cover empty space in bottom deck

Main configuration DE*		Basic configurations						
	L2	159.44	145.04	145.04	159.44	159.44	159.44	159.44
	L1	173.83	159.44	159.44	173.83	173.83	173.83	173.83
	L11	159.44	145.04	145.04	159.44	159.44	159.44	159.44
	L2	173.83	159.44	159.44	173.83	173.83	173.83	173.83
	L1	159.44	145.04	145.04	159.44	159.44	159.44	159.44
	L11	159.44	145.04	145.04	159.44	159.44	159.44	159.44
	L2	145.04	130.64	130.64	145.04	145.04	145.04	145.04
	L1	188.23	173.83	173.83	188.23	188.23	188.23	188.23
	L11	57.59	43.19	43.19	57.59	57.59	57.59	57.59
	L2	145.04	130.64	130.64	145.04	145.04	145.04	145.04
	L1	188.23	173.83	173.83	188.23	188.23	188.23	188.23
	L11	57.59	43.19	43.19	57.59	57.59	57.59	57.59
	L2	188.23	173.83	173.83	188.23	188.23	188.23	188.23
	L1	145.04	130.64	130.64	145.04	145.04	145.04	145.04
	L11	86.39	71.99	71.99	86.39	86.39	86.39	86.39
	L2	188.23	173.83	173.83	188.23	188.23	188.23	188.23
	L1	145.04	130.64	130.64	145.04	145.04	145.04	145.04
	L11	86.39	71.99	71.99	86.39	86.39	86.39	86.39
	L2	116.24	101.85	101.85	116.24	116.24	116.24	116.24
	L1	145.04	130.64	130.64	145.04	145.04	145.04	145.04
	L11	57.59	43.19	43.19	57.59	57.59	57.59	57.59
	L2	116.24	101.85	101.85	116.24	116.24	116.24	116.24
	L1	145.04	130.64	130.64	145.04	145.04	145.04	145.04
	L11	57.59	43.19	43.19	57.59	57.59	57.59	57.59
	L2	145.04	130.64	130.64	145.04	145.04	145.04	145.04
	L1	116.24	101.85	101.85	116.24	116.24	116.24	116.24
	L11	86.39	71.99	71.99	86.39	86.39	86.39	86.39
	L2	145.04	130.64	130.64	145.04	145.04	145.04	145.04
	L1	116.24	101.85	101.85	116.24	116.24	116.24	116.24
	L11	86.39	71.99	71.99	86.39	86.39	86.39	86.39
	L2	159.44	145.04	145.04	159.44	159.44	159.44	159.44
	L1	188.23	173.83	173.83	188.23	188.23	188.23	188.23
	L11	159.44	145.04	145.04	159.44	159.44	159.44	159.44
	L2	188.23	173.83	173.83	188.23	188.23	188.23	188.23
	L1	159.44	145.04	145.04	159.44	159.44	159.44	159.44
	L11	14.40	14.40	14.40	14.40	14.40	14.40	14.40
	L2	188.23	173.83	173.83	188.23	188.23	188.23	188.23
	L1	159.44	145.04	145.04	159.44	159.44	159.44	159.44
	L11	14.40	14.40	14.40	14.40	14.40	14.40	14.40
	L2	159.44	145.04	145.04	159.44	159.44	159.44	159.44
	L1	188.23	173.83	173.83	188.23	188.23	188.23	188.23
	L11	159.44	145.04	145.04	159.44	159.44	159.44	159.44
	L2	188.23	173.83	173.83	188.23	188.23	188.23	188.23
	L1	188.23	173.83	173.83	188.23	188.23	188.23	188.23
	L11	14.40	14.40	14.40	14.40	14.40	14.40	14.40
	L2	159.44	145.04	145.04	159.44	159.44	159.44	159.44
	L1	188.23	173.83	173.83	188.23	188.23	188.23	188.23
	L11	14.40	14.40	14.40	14.40	14.40	14.40	14.40

* Include Droplet Eliminator after Cooling Coil

L1- doesn't cover empty space in bottom deck



DIMENSIONS -AVS 12 - 65 WITH ENERGY WHEEL

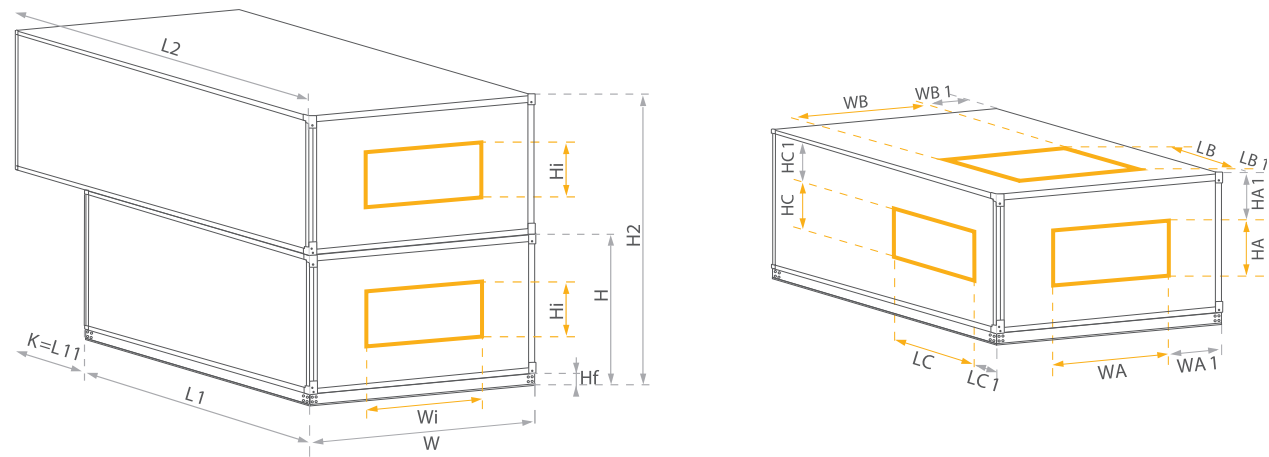

AIR INLET / DISCHARGE DIMENSIONS

END FULL (FF)	UNIT	WA	HA	WA1	HA1
AVS 012	AVS 012	32.32	12.13	3.15	3.15
AVS 016	AVS 016	37.91	14.17	3.15	3.15
AVS 020	AVS 020	40.47	17.32	3.15	3.15
AVS 030	AVS 030	47.20	22.64	3.15	3.15
AVS 040	AVS 040	52.76	27.36	3.15	3.15
AVS 055	AVS 055	59.84	31.30	3.15	3.15
AVS 065	AVS 065	68.94	32.76	3.15	3.15

END (FS)	UNIT	WA	HA	WA1	HA1
AVS 012	AVS 012	25.97	7.97	6.34	5.24
AVS 016	AVS 016	33.97	7.97	5.16	6.26
AVS 020	AVS 020	25.97	11.97	10.43	5.83
AVS 030	AVS 030	33.97	11.97	9.80	8.50
AVS 040	AVS 040	40.51	17.36	9.29	8.19
AVS 055	AVS 055	47.24	22.68	9.47	7.48
AVS 065	AVS 065	47.24	22.68	14.02	8.23

Side (BS)	UNIT	HC	LC	HC1	LC1
AVS 012	AVS 012	10.94	7.94	4.33	3.74
AVS 016	AVS 016	12.94	7.94	4.33	3.74
AVS 020	AVS 020	15.94	11.94	4.33	3.82
AVS 030	AVS 030	20.94	11.94	4.33	3.98
AVS 040	AVS 040	16.26	14.96	6.89	8.70
AVS 055	AVS 055	24.13	14.96	6.89	6.73
AVS 065	AVS 065	24.13	14.96	6.89	7.46

UNIT CODING

AVS - XX

AVS - type of AHU family
 XXX - size of unit (equal to the rated air flow in cfm*0.001)
 R/L - inspection side (R- right, L- left)
 PHC - symbols of main thermodynamic functions (basic functions)
 Length depends on AHU equipment



DIMENSIONS -AVS 85-380 WITH ENERGY WHEEL

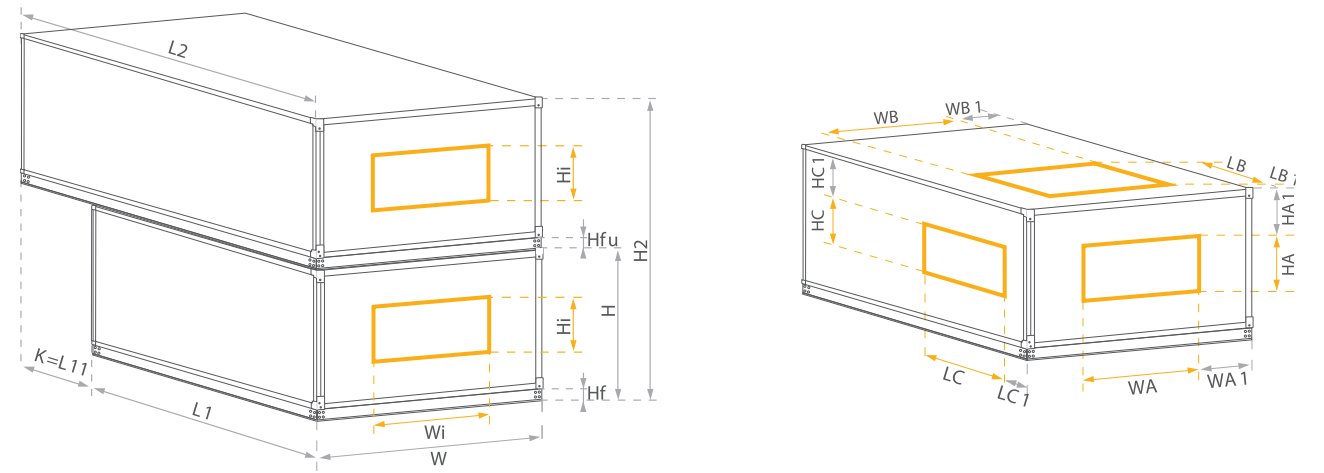

AIR INLET / DISCHARGE DIMENSIONS

END FULL (FF)	UNIT	WA	HA	WA1	HA1
AVS 085	AVS 085	76.57	36.73	3.15	3.15
AVS 100	AVS 100	76.57	44.76	3.15	3.15
AVS 130	AVS 130	92.64	44.76	3.15	3.15
AVS 170	AVS 170	96.26	56.54	3.15	3.15
AVS 230	AVS 230	115.94	65.71	3.15	3.15
AVS 300	AVS 300	135.63	65.71	3.15	3.15
AVS 380	AVS 380	140.04	84.49	3.15	3.15

END (FS)	UNIT	WA	HA	WA1	HA1
AVS 085	AVS 085	59.88	31.34	11.52	5.87
AVS 100	AVS 100	59.88	31.34	11.52	9.88
AVS 130	AVS 130	76.61	36.77	11.18	7.17
AVS 170	AVS 170	76.61	36.77	12.99	13.07
AVS 230	AVS 230	104.37	36.77	8.96	17.64
AVS 300	AVS 300	124.06	36.77	8.96	17.64
AVS 380	AVS 380	127.99	36.77	9.19	27.05

Side (BS)	UNIT	HC	LC	HC1	LC1
AVS 085	AVS 085	28.07	29.13	6.89	7.48
AVS 100	AVS 100	35.94	29.13	6.89	7.56
AVS 130	AVS 130	35.94	29.13	6.89	7.56
AVS 170	AVS 170	47.76	29.13	6.89	7.54
AVS 230	AVS 230	59.57	29.13	6.89	6.22
AVS 300	AVS 300	59.57	29.13	6.89	6.22
AVS 380	AVS 380	75.31	29.13	6.89	7.74

UNIT CODING

AVS - XX

AVS - type of AHU family
 XXX - size of unit (equal to the rated air flow in cfm*0.001)
 R/L - inspection side (R- right, L- left)
 PHC - symbols of main thermodynamic functions (basic functions)
 Length depends on AHU equipment



AVS LITE 8-40 - SUPPLY & EXHAUST

Rated parameters		Recommended range of airflow																							
Size		AVS 008				AVS 012				AVS 016				AVS 020				AVS 030				AVS 040			
15 000	[CFM]	[Bar chart showing airflow ranges for each unit size]																							
10 000		[Bar chart showing airflow ranges for each unit size]																							
5 000		[Bar chart showing airflow ranges for each unit size]																							
0		[Bar chart showing airflow ranges for each unit size]																							
Min.		332	427	427	427	480	618	618	618	636	819	819	819	806	1037	1037	1037	1185	1524	1524	1524	1567	1945	1945	1945
Max.		2140	1883	1254	924	3091	2719	1817	1339	4096	3605	2486	1832	5186	4564	3331	2454	7622	6708	4835	3563	10078	8559	6697	4934
H _f		3.54																							
H		21.97				21.97				24.02				27.17				32.48				37.20			
W		27.95				38.62				44.21				46.77				53.50				59.06			
W _i		24.02				34.68				40.28				42.83				49.57				55.12			
H _i		14.49				14.49				16.54				19.69				25.00				29.72			

Main configuration		Basic configurations					
	L1	29,9	29,9	44,3	44,3	44,3	44,3
	L1	44,3	44,3	44,3	44,3	58,69	58,69
	L1	44,3	44,3	58,69	58,69	58,69	58,69
	L1	44,3	58,69	58,69	58,69	58,69	58,69
	L1	44,3	58,69	58,69	58,69	58,69	58,69
	L1	58,69	58,69	58,69	58,69	73,09	73,09
	L1	58,69	58,69	73,09	73,09	73,09	73,09
	L1	58,69	73,09	73,09	73,09	73,09	73,09
	L1	58,69	73,09	73,09	73,09	73,09	73,09

Units with external filters instead of internal are shorter by 14.4 inches

		Additional functions					
Empty section	L _{min}	29.86	29.86	29.86	29.86	29.86	29.86
	L _{max}	29.86	29.86	29.86	29.86	29.86	29.86
Mixing box	L	29.86	29.86	29.86	29.86	29.86	29.86



DIMENSIONS - AVS LITE 8-40 - SUPPLY & EXHAUST

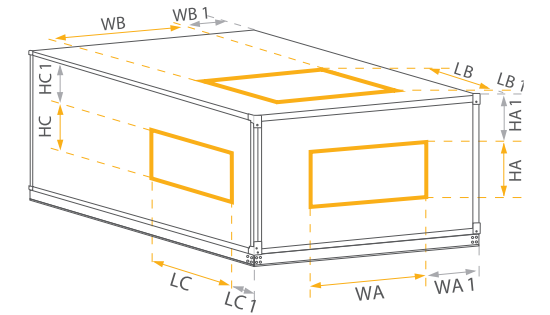
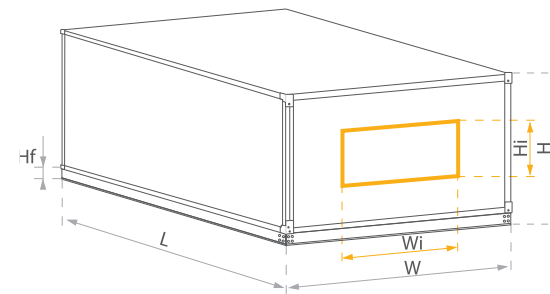

AIR INLET / DISCHARGE DIMENSIONS

END FULL (FF)				
UNIT	WA	HA	WA1	HA1
AVS 008	21.65	12.13	3.15	3.15
AVS 012	32.32	12.13	3.15	3.15
AVS 016	37.91	14.17	3.15	3.15
AVS 020	40.47	17.32	3.15	3.15
AVS 030	47.20	22.64	3.15	3.15
AVS 040	52.76	27.36	3.15	3.15

END (FS)				
UNIT	WA	HA	WA1	HA1
AVS 008	17.99	7.99	5.03	5.23
AVS 012	25.98	7.99	6.33	5.23
AVS 016	34.02	7.99	5.13	6.23
AVS 020	25.98	12.01	10.43	5.83
AVS 030	34.02	12.01	9.83	8.53
AVS 040	40.47	17.32	9.29	8.19

Top (US)				
UNIT	WB	LB	WB1	LB1
AVS 008	17.99	7.99	5.03	4.33
AVS 012	25.98	7.99	6.33	4.33
AVS 016	34.02	7.99	5.13	4.33
AVS 020	25.98	12.01	10.43	4.33
AVS 030	34.02	12.01	9.83	4.33
AVS 040	40.47	17.32	9.29	8.27

Top (US)				
UNIT	WB	LB	WB1	LB1
AVS 008	17.94	7.94	5.00	11.46
AVS 012	25.94	7.94	6.34	11.46
AVS 016	33.94	7.94	5.16	11.46
AVS 020	25.94	11.94	10.43	9.46
AVS 030	33.94	11.94	9.80	9.46
AVS 040	47.20	22.64	5.93	8.66

UNIT CODING

AVS - XXX - R/L - EM / HC / EM

AVS - type of AHU family
 XXX - size of unit (equal to the rated air flow in cfm)
 R/L - inspection side (R- right, L-left)
 EM - symbols of additional functions upstream main functions
 HC - symbols of main thermodynamic functions (basic functions)
 EM - symbols of additional functions downstream main functions
 Length depends on AHU equipment

Side (BS)				
UNIT	HC	LC	HC1	LC1
AVS 008	10.94	7.94	4.33	3.74
AVS 012	10.94	7.94	4.33	3.74
AVS 016	12.94	7.94	4.33	3.74
AVS 020	15.94	11.94	4.33	3.82
AVS 030	20.94	11.94	4.33	3.98
AVS 040	16.26	14.96	6.89	8.70



AVS LITE 8-40 - CROSS-FLOW PLATE

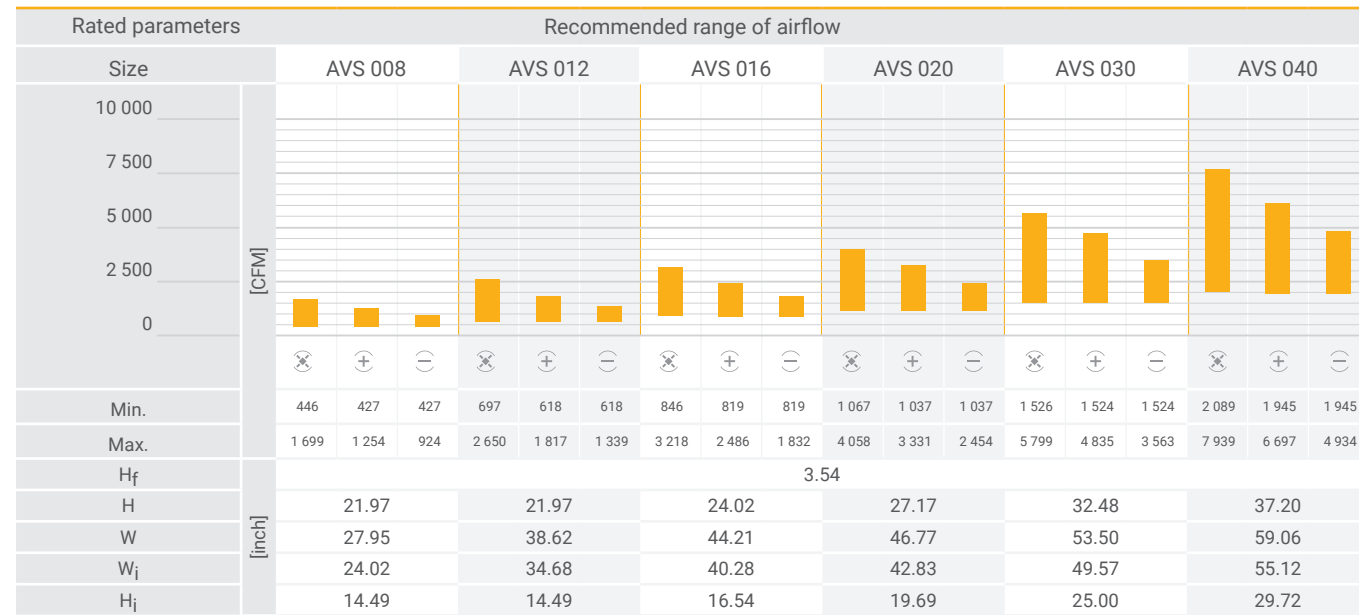

Main configuration DE*		Basic configurations					
	L2	58,69	58,69	87,49	87,49	87,49	101,89
	L1	58,69	58,69	73,09	87,49	87,49	101,89
	L2	73,09	73,09	73,09	87,49	101,89	101,89
	L1	58,69	58,69	73,09	87,49	87,49	101,89
	L2	58,69	58,69	87,49	87,49	87,49	101,89
	L1	73,09	73,09	87,49	87,49	87,49	101,89
	L2	73,09	73,09	73,09	87,49	101,89	101,89
	L1	73,09	73,09	87,49	87,49	87,49	101,89
	L2	58,69	58,69	87,49	87,49	87,49	101,89
	L1	73,09	73,09	87,49	87,49	101,89	116,28
	L2	73,09	73,09	73,09	87,49	101,89	101,89
	L1	73,09	73,09	87,49	87,49	101,89	116,28

* Include Droplet Eliminator after Cooling Coil

L1- doesn't cover empty space in bottom deck

Main configuration DE*		Basic configurations					
	L2	58,69	58,69	87,49	87,49	87,49	101,89
	L1	73,09	73,09	87,49	101,89	101,89	116,28
	L2	73,09	73,09	73,09	87,49	101,89	101,89
	L1	73,09	73,09	87,49	101,89	101,89	116,28
	L2	58,69	58,69	87,49	87,49	87,49	101,89
	L1	73,09	73,09	87,49	87,49	87,49	101,89
	L2	73,09	73,09	73,09	87,49	101,89	101,89
	L1	73,09	73,09	87,49	87,49	87,49	101,89
	L2	58,69	58,69	87,49	87,49	87,49	101,89
	L1	73,09	73,09	73,09	87,49	101,89	101,89
	L2	73,09	73,09	73,09	87,49	101,89	101,89
	L1	73,09	73,09	87,49	87,49	101,89	116,28
	L2	58,69	58,69	87,49	87,49	87,49	101,89
	L1	87,49	87,49	87,49	87,49	101,89	101,89

* Include Droplet Eliminator after Cooling Coil

L1- doesn't cover empty space in bottom deck



AVS LITE 12 - 40 WITH ENERGY WHEEL

Main configuration DE*		Basic configurations					
	L2	73,09	73,09	73,09	87,49	101,89	101,89
	L1	87,49	87,49	87,49	87,49	101,89	101,89
	L2	58,69	58,69	87,49	87,49	87,49	101,89
	L1	87,49	87,49	87,49	87,49	116,28	116,28
	L2	73,09	73,09	73,09	87,49	101,89	101,89
	L1	87,49	87,49	87,49	87,49	116,28	116,28
	L2	58,69	58,69	87,49	87,49	87,49	101,89
	L1	87,49	87,49	87,49	101,89	116,28	116,28
	L2	73,09	73,09	73,09	87,49	101,89	101,89
	L1	87,49	87,49	87,49	101,89	116,28	116,28
	L2	58,69	58,69	87,49	87,49	87,49	101,89
	L1	87,49	87,49	87,49	101,89	116,28	116,28
	L2	73,09	73,09	73,09	87,49	101,89	101,89
	L1	87,49	87,49	87,49	101,89	116,28	116,28

* Include Droplet Eliminator after Cooling Coil

L1- doesn't cover empty space in bottom deck

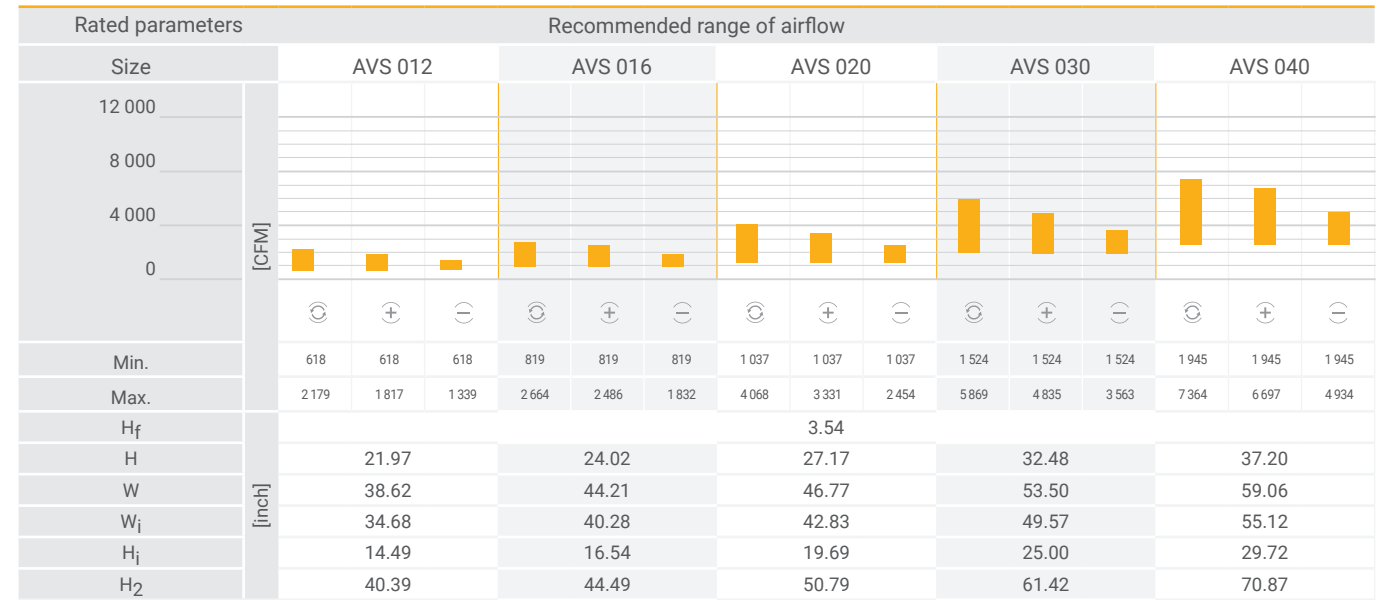

Main configuration DE*		Basic configurations				
	L2	58,69	73,09	73,09	73,09	73,09
	L1	58,69	58,69	73,09	73,09	73,09
	L2	58,69	73,09	73,09	73,09	73,09
	L1	58,69	58,69	73,09	73,09	73,09
	L2	58,69	73,09	73,09	73,09	73,09
	L1	73,09	73,09	73,09	73,09	73,09
	L2	58,69	58,69	73,09	73,09	73,09
	L1	73,09	73,09	73,09	73,09	73,09
	L2	58,69	73,09	73,09	73,09	73,09
	L1	73,09	73,09	73,09	87,49	87,49
	L2	58,69	58,69	73,09	73,09	73,09
	L1	73,09	73,09	73,09	87,49	87,49
	L2	58,69	73,09	73,09	73,09	73,09
	L1	73,09	73,09	87,49	87,49	87,49
	L2	58,69	58,69	73,09	73,09	73,09
	L1	73,09	73,09	87,49	87,49	87,49
	L2	58,69	73,09	73,09	73,09	73,09
	L1	73,09	73,09	87,49	87,49	87,49
	L2	58,69	58,69	73,09	73,09	73,09
	L1	73,09	73,09	87,49	87,49	87,49

* Include Droplet Eliminator after Cooling Coil

L1- doesn't cover empty space in bottom deck



DIMENSIONS AVS LITE 8-40 - CROSS-FLOW PLATE

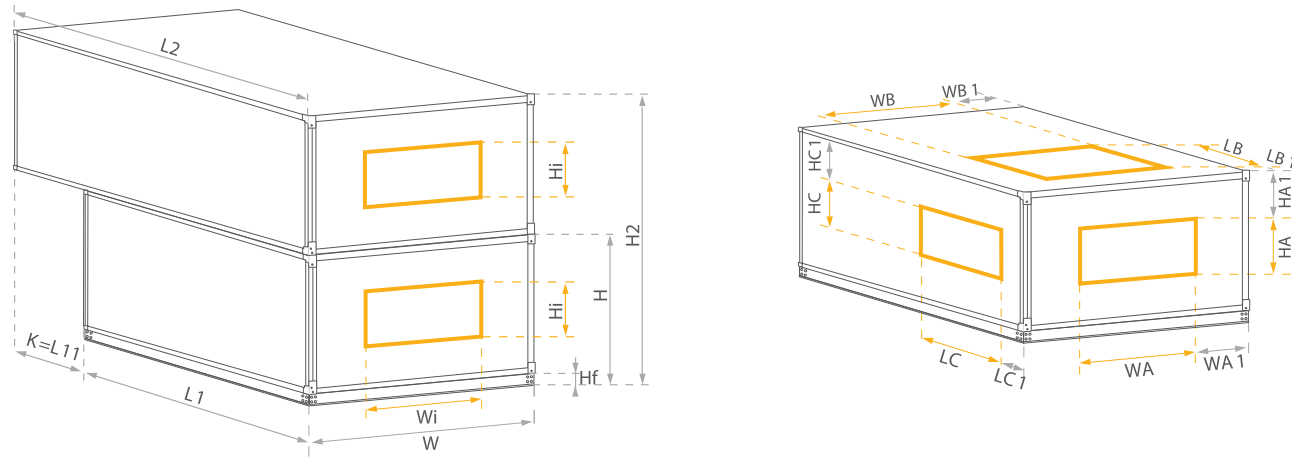

AIR INLET / DISCHARGE DIMENSIONS

END FULL (FF) 					END (FS) 				
UNIT	WA	HA	WA1	HA1	UNIT	WA	HA	WA1	HA1
AVS 008	21.65	12.13	3.15	3.15	AVS 008	17.97	7.97	5.00	5.24
AVS 012	32.32	12.13	3.15	3.15	AVS 012	25.97	7.97	6.34	5.24
AVS 016	37.91	14.17	3.15	3.15	AVS 016	33.97	7.97	5.16	6.26
AVS 020	40.47	17.32	3.15	3.15	AVS 020	25.97	11.97	10.43	5.83
AVS 030	47.20	22.64	3.15	3.15	AVS 030	33.97	11.97	9.80	8.50
AVS 040	52.76	27.36	3.15	3.15	AVS 040	40.51	17.36	9.29	8.19

Side (BS) 				
UNIT	HC	LC	HC1	LC1
AVS 008	10.94	7.94	4.33	3.74
AVS 012	10.94	7.94	4.33	3.74
AVS 016	12.94	7.94	4.33	3.74
AVS 020	15.94	11.94	4.33	3.82
AVS 030	20.94	11.94	4.33	3.98
AVS 040	16.26	14.96	6.89	8.70

UNIT CODING

AVS - XX



AVS - type of AHU family
 XXX - size of unit (equal to the rated air flow in cfm*0.001)
 R/L - inspection side (R- right, L -left)
 PHC - symbols of main thermodynamic functions (basic functions)
 Length depends on AHU equipment

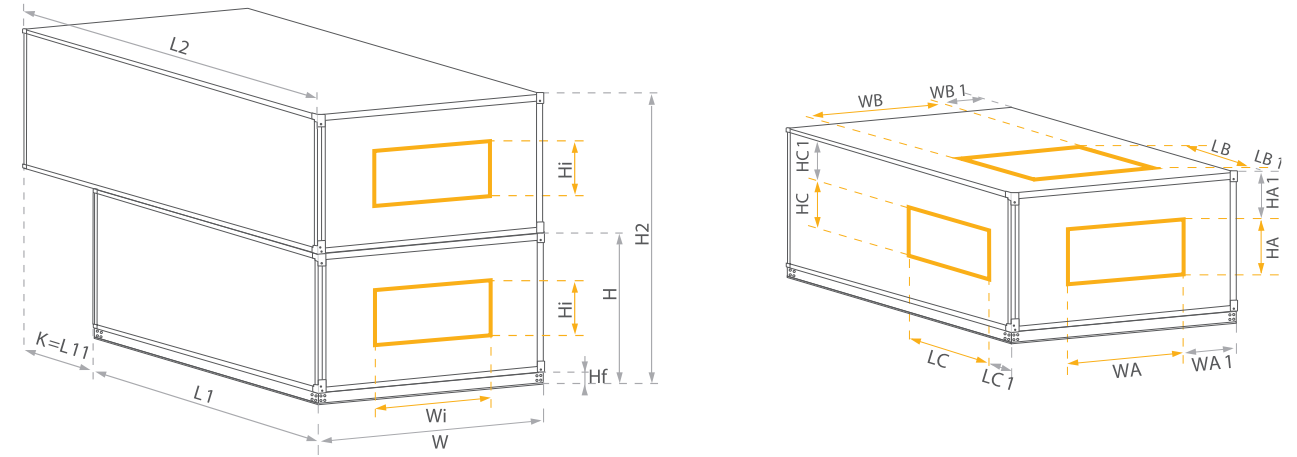

DIMENSIONS - AVS LITE 12 - 40 WITH ENERGY WHEEL



AIR INLET / DISCHARGE DIMENSIONS

END FULL (FF) 					END (FS) 				
UNIT	WA	HA	WA1	HA1	UNIT	WA	HA	WA1	HA1
AVS 012	32.32	12.13	3.15	3.15	AVS 012	25.97	7.97	6.34	5.24
AVS 016	37.91	14.17	3.15	3.15	AVS 016	33.97	7.97	5.16	6.26
AVS 020	40.47	17.32	3.15	3.15	AVS 020	25.97	11.97	10.43	5.83
AVS 030	47.20	22.64	3.15	3.15	AVS 030	33.97	11.97	9.80	8.50
AVS 040	52.76	27.36	3.15	3.15	AVS 040	40.51	17.36	9.29	8.19

Side (BS) 				
UNIT	HC	LC	HC1	LC1
AVS 012	10.94	7.94	4.33	3.74
AVS 016	12.94	7.94	4.33	3.74
AVS 020	15.94	11.94	4.33	3.82
AVS 030	20.94	11.94	4.33	3.98
AVS 040	16.26	14.96	6.89	8.70

UNIT CODING

AVS - XX

AVS - type of AHU family
 XXX - size of unit (equal to the rated air flow in cfm*0.001)
 R/L - inspection side (R- right, L -left)
 PHC - symbols of main thermodynamic functions (basic functions)
 Length depends on AHU equipment



AVS - VERTICAL CONFIGURATIONS

Rated parameters		Recommended range of airflow																							
Size		AVS 008		AVS 012			AVS 016			AVS 020			AVS 030			AVS 040									
15 000	[CFM]																								
10 000																									
5 000																									
0																									
Min.		332	427	427	427	480	618	618	618	636	819	819	819	806	1 037	1 037	1 037	1 185	1 524	1 524	1 524	1 567	1 945	1 945	1 945
Max.		2 140	1 883	1 254	924	3 091	2 719	1 817	1 339	4 096	3 605	2 486	1 832	5 186	4 564	3 331	2 454	7 622	6 708	4 835	3 563	10 078	8 559	6 697	4 934
H _{fd}		3.54																							
H _{fu}		0.00																							
H		21.97		21.97			24.02			27.17			32.48			37.20									
W		27.95		38.62			44.21			46.77			53.50			59.06									
W _i		24.02		34.68			40.28			42.83			49.57			55.12									
H _{ui}		19.69		19.69			19.69			25.00			25.00			29.72									
H _{di}		14.49		14.49			16.54			19.69			25.00			29.72									
H ₂		45.59		45.59			47.64			56.10			61.42			70.87									

		Basic configurations					
	L2	29.86	29.86	29.86	29.86	29.86	29.86
	L1	29.86	29.86	29.86	29.86	29.86	29.86
	L2	29.86	29.86	29.86	29.86	29.86	29.86
	L1	29.86	29.86	29.86	29.86	29.86	29.86
	L2	29.86	29.86	29.86	29.86	29.86	29.86
	L1	29.86	29.86	29.86	29.86	29.86	29.86
	L2	29.86	29.86	29.86	29.86	29.86	29.86
	L1	29.86	29.86	29.86	29.86	29.86	29.86
	L2	29.86	29.86	29.86	29.86	29.86	29.86
	L1	58.65	58.65	58.65	58.65	58.65	58.65
	L2	29.86	29.86	29.86	29.86	29.86	29.86
	L1	58.65	58.65	58.65	58.65	58.65	58.65
	L2	29.86	29.86	29.86	29.86	29.86	29.86
	L1	58.65	58.65	58.65	58.65	58.65	58.65
	L2	29.86	29.86	29.86	29.86	29.86	29.86
	L1	58.65	58.65	58.65	58.65	58.65	58.65



DIMENSIONS - VERTICAL CONFIGURATIONS

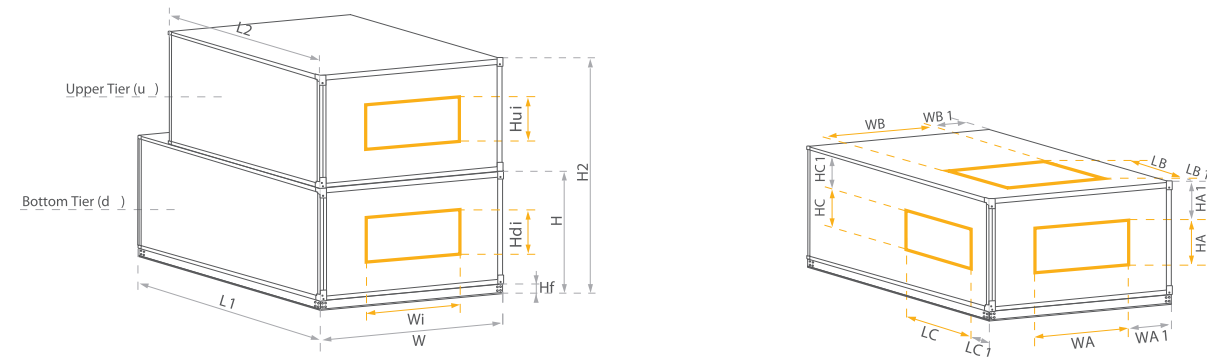

AIR INLET / DISCHARGE DIMENSIONS

END FULL (FF)					
Unit	WA	HA	WA1	HA1	
AVS008	21.63	17.31	3.13	3.13	
AVS012	32.31	17.31	3.13	3.13	
AVS016	37.94	17.31	3.13	3.13	
AVS020	40.50	22.63	3.13	3.13	
AVS030	47.19	22.63	3.13	3.13	
AVS 040	52.75	27.38	3.13	3.13	

END FULL (FF)					
Unit	WA	HA	WA1	HA1	
AVS008	21.31	11.81	3.28	3.28	
AVS012	32.00	11.81	3.28	3.28	
AVS016	37.62	13.86	3.28	3.28	
AVS020	40.19	17.01	3.28	3.28	
AVS030	46.87	22.32	3.28	3.28	
AVS 040	52.44	27.05	3.28	3.28	

END (FS)					
Unit	WA	HA	WA1	HA1	
AVS008	18.00	8.00	4.60	11.12	
AVS012	26.00	8.00	5.90	11.12	
AVS016	34.00	8.00	4.70	10.62	
AVS020	26.00	12.00	10.00	11.94	
AVS030	34.00	12.00	9.40	11.94	
AVS 040	48.00	12.00	5.10	16.66	

END (FS)					
Unit	WA	HA	WA1	HA1	
AVS008	17.94	7.94	4.66	4.84	
AVS012	25.94	7.94	5.91	4.84	
AVS016	33.94	7.94	4.72	5.84	
AVS020	25.94	11.94	10.03	5.41	
AVS030	33.94	11.94	9.41	8.16	
AVS 040	40.50	17.31	9.28	8.22	

TOP (US)					
Unit	WB	LB	WB1	LB1	
AVS008	18.00	8.00	4.60	10.90	
AVS012	26.00	8.00	5.90	10.90	
AVS016	34.00	8.00	4.70	10.90	
AVS020	26.00	12.00	10.00	8.90	
AVS030	34.00	12.00	9.40	8.90	
AVS 040	48.00	12.00	5.10	8.90	

TOP (US)					
Unit	WB	LB	WB1	LB1	
AVS008	17.94	7.94	4.66	3.91	
AVS012	25.94	7.94	5.91	3.91	
AVS016	33.94	7.94	4.72	3.91	
AVS020	25.94	11.94	10.03	3.91	
AVS030	33.94	11.94	9.41	3.91	
AVS 040	40.50	17.31	9.28	7.84	

Side (BS)					
Unit	HC	LC	HC1	LC1	
AVS008	8.00	11.00	11.12	9.40	
AVS012	8.00	11.00	11.12	9.40	
AVS016	8.00	13.00	10.62	8.40	
AVS020	12.00	16.00	11.94	6.90	
AVS030	12.00	21.00	11.94	4.40	
AVS 040	12.00	21.00	16.66	4.40	

Side (BS)					
Unit	HC	LC	HC1	LC1	
AVS008	10.94	7.94	3.34	3.91	
AVS012	10.94	7.94	3.34	3.91	
AVS016	12.94	7.94	3.34	3.91	
AVS020	15.94	11.94	3.41	3.91	
AVS030	20.94	11.94	3.66	3.91	
AVS 040	16.25	14.94	8.72	6.47	

UNIT CODING

AVS - XXX - R/L - RHC

AVS - type of AHU family
 XXX - size of unit (equal to the rated air flow in cfm*0.001)
 R/L - inspection side (R- right, L- left)
 RHC - symbols of main thermodynamic functions (basic functions)
 Length depends on AHU equipment



05

Connection and
controls



CONNECTING POINT

The Connecting Point is the power supply and VFD Enclosure, the internal wiring system of the air-handling unit related to power supply and control of fan motors. It is mounted separately for the supply and exhaust fan sections.

It consists of a casing, a frequency converter (VFD), surge protection, emergency (service) switch, strip connector, factory-produced internal power circuits, and control wiring of the fan drive system (motor-inverter). In the case of vertical air-handling units, an external wired outlet is mounted on the casing and connected to the Connecting Point.

The Connecting Point is equipped with aggregate terminals for power supply circuits; inverter circuits are factory-connected to these terminals.



CONSTRUCTION AND WIRING



THE MAIN BENEFITS OF AIR-HANDLING UNITS EQUIPPED WITH THE CONNECTING POINT ARE AS FOLLOWS:

- » the certainty of correctness of internal connections supplying the motor and the VFD
- » reliability of factory-tested connections and air-handling unit operation
- » on-site time-savings on wiring
- » lower costs of the whole installation
- » factory installation of the service switch
- » clear liability of the producer for the connection and configuration of inverters and motors



CONTROLS

VTS uses control algorithms that have been developed with an emphasis on energy savings, while at the same time maintaining the required parameters of the air supplied and ensuring reliability of our units.

For management of our American VENTUS air handling units we recommend our control application based on PLC controller, supporting all advanced control functions and variable ways of external communication including integration with Building Management Systems.

NEW FEATURES

MEASUREMENT AND CONTROL OF THE CONSTANT AIR VOLUME

- » adjustment of the preset constant air volume under changing flow resistance - compensation of changing internal resistance of the AHU (e.g. with varying degrees of air filter dirt, different setpoint of the mixing box, etc.)
- » adjustment of the fan power to the current needs of the installation
- » readiness of the AHU to work with the required performance immediately after installation

CONSTANT PRESSURE CONTROL WITH VARIABLE AIR VOLUME

- » control of constant, preset air pressure at variable volume (efficiency change is carried out through the air distribution system – e.g. VAV controllers)

CO₂

- » automatic modulation of the amount of outside air (keeping the CO₂ concentration below the set value)
- » optimization of consumption of heat and electricity

ELECTRIC HEATER CONTROL

- » smooth control system that adjusts power to the current demand

HUMIDITY CONTROL

- » control over air humidifying - both evaporative and steam
- » supports control of the drying process

MIXING BOX CONTROL

- » smooth control of the mixing box, external signal or as in the CO₂ control function, etc.
- » optimization of the ventilation air to save energy



MAIN ELEMENTS

HMI SERVICE



Function and Application

- » setting and reading of advanced operating parameters of ventilation or supply units
- » management and cancellation of units operational errors is done by full text description
- » management of the controller main calendar

Operation parameters

- » power supply: directly from the UPC3 controller
- » communication port: serial port, RS485 standard
- » communication cable length: max. 3,600ft
- » connection method: 1:1
- » protection class: NEMA 2
- » ambient temperature: -4 +140°F / φ<85%, without condensation

VARIABLE FREQUENCY DRIVES



Function and Application

- » smooth regulation of the AHU air flow by proportional change of the motor-fan unit rotational speed
- » maintaining fixed AHU operating parameters at varying air flow resistance of the ductworks
- » protection of maximal value of motor current
- » controlling of fan start-up with simultaneous protection of maximal value of start-up current
- » integration with external analog and binary signals
- » displaying and modification of fan-set working parameters

Operation parameters

- » supply Frequency: 50/60 Hz (48 Hz to 62 Hz)
- » control
 - method: Type of control: V/f (Scalar); VVW: Voltage vector control; PWM SVM (Space Vector Modulation)
 - output Frequency: 0 to 500 Hz, resolution of 0.015 Hz

- » analog Inputs:
 - 1 insulated input. Levels: (0 to 10) V or (0 a 20) mA or (4 to 20) mA
 - programmable functions
- » digital Inputs:
 - 4 insulated inputs
 - programmable functions:
 - Active high (PNP)
 - Active low (NPN)
- » analog Output
 - 1 insulated output. Level (0 to 10) V or (0 to 20) mA or (4 to 20) mA
 - programmable functions
- » relay Output
 - 1 relay with NA/NF contact.
 - maximum voltage: 240 VAC
 - maximum current 0.5 A
 - programmable functions
- » communication Interface RS 485
 - insulated RS485
 - modbus-RTU protocol with maximum communication of 38.4kbps
- » enclosure
 - NEMA1/IP20



DUCT TEMPERATURE SENSOR



Function and Application

- » measurement of the temperature of supply, exhaust and outside air
- » securing max. and min. temperature of supply air
- » protection against frost on the energy recovery unit via the temperature measurement of air exhausted upstream the energy recovery unit

Operation parameters

- » measurement range: -40°F -158 °F
- » air humidity: 5 - 100 %
- » measuring element: NTC 10k
- » output signal: resistance
- » cables length: max. 300 ft
- » protection class: IP 54

DIFFERENTIAL PRESSURE SWITCH



Function and Application

- » monitoring the filter contamination in the Air Handling Unit by measuring the difference of static pressure before and after the filter
- » control of the operation of a direct driven fan unit in case of cooperation with electric heater

Operation parameters

- » measurement: 0.12-1.20 in WG – filters of class MERV 6 - 15
- » rated operating voltage: 250V AC (Imax=3A)
- » output signal: potential-free contact, NO or NC according to the application
- » switching capacity: 1mln of cycles (at temp. of 140 °F)
- » protection class: NEMA 3
- » ambient temperature: -4 °F +140 °F

LOW LIMIT THERMOSTAT SWITCH



Function and Application

- » when the air temperature drops below the minimum allowable temperature, signal from the thermostat stops AHU fans, closes external air dampers and adjusts control valve of the heater to the max. flow of heating medium
- » switching into permanent alarm condition if the AHU protection is triggered three times within an hour

Operation parameters

- » measurement range: -0.4 +59 °F
- » default switching threshold setting: 41 °F
- » hysteresis: 1.7 - 12K
- » Rated operating voltage: 30 V DC, 230 VAC
- » output signal: potential-free (switchover contact)
- » protection class: NEMA 3



THREE-WAY VALVE WITH ELECTRIC ACTUATOR



Function and Application

- » temperature adjustment of the medium flowing through the hydronic coil
- » quality hydronic heater capacity regulation (system based on additional recirculation pump)
- » quantity hydronic cooler capacity regulation

Operation parameters

- » actuator:
 - adjustment range: 0 -100%
 - supply voltage: 24 V AC/DC
 - input signal: 0-10 V DC
 - rotation angle: 90°
 - protection class: NEMA 2
 - ambient temperature: -22 +122 °F
- » valve:
 - operating characteristics: Equal percentage/proportional Cv: 3 / 4.7 / 7.4 / 19 / 29 / 46 / 68 / 91
 - differential Pressure: 50 psi for typical applications
 - medium temperature: 0°F - 250°F

0-10 V AIR DAMPER ACTUATOR



Function and Application

- » mixing ratio control for outdoor and room-exhausted air (economizer): 0-10 V actuator
- » control of bypass air damper opening level for the Plate Cross-Flow – anti-frost protection of the energy recovery system
- » 0-10 V actuator:
 - actuator with spring return
 - economizer fresh air side
- » actuator with no spring return:
 - economizer return air side
 - by-pass damper for cross-plate based energy recovery system

Operation parameters

- » regulation method: smooth 0-100%
- » supply voltage: 24 VAC
- » input signal: 0 -10 VDC
- » rated torque: 90 in-lbs
- » rotation angle 90°
- » full opening time: 0 10 V: 80 - 90s;
- » spring-forced return: 10s
- » max. air damper area: 43 ft2
- » protection class: NEMA 2
- » ambient temperature: -22 +122 °F

HUMIDITY SENSOR



Function and Application

- » multiple ranges as measurement windows available
- » innovative self-calibrating algorithm
- » long term stability and accuracy

Operation parameters

- » microcontroller based design
- » supply voltage: 24 V AC/DC
- » 1 analogue output (0-10 VDC / 0-20 mA)
- » modbus RTU (RS485) Communication



CONTROL APPLICATIONS LIST

AP - control system application for air supply-exhaust units with cross-flow heat exchanger

Application code	Functions available in particular applications					
	HW	DX	DX	PRC. BPS	MIX. CMBR	SUMMER
AP 32				✓		
AP 41	✓			✓		
AP 33		✓		✓		
AP 36	✓	✓		✓		
AP 37			✓	✓		
AP 40	✓		✓	✓		
AP 160				✓		✓
AP 161	✓			✓		✓
AP 164		✓		✓		✓
AP 165	✓	✓		✓		✓
AP 168			✓	✓		✓
AP 169	✓		✓	✓		✓

AR - control system application for air supply-exhaust units with thermal wheel

Application code	Functions available in particular applications					
	HW	DX	DX	PRC. BPS	MIX. CMBR	SUMMER
AP 0						
AP 1	✓					
AP 4		✓				
AP 5	✓	✓				
AP 8			✓			
AP 9	✓		✓			
AP 128						✓
AP 129	✓					✓
AP 132		✓				✓
AP 133	✓	✓				✓
AP 136			✓			✓
AP 137	✓		✓			✓

AS - control system application for air supply units

Application code	Functions available in particular applications					
	HW	DX	DX	PRC. BPS	MIX. CMBR	SUMMER
AP 1	✓					
AP 4		✓				
AP 5	✓	✓				
AP 8			✓			
AP 9	✓		✓			
AP 65	✓				✓	
AP 68		✓			✓	
AP 69	✓	✓			✓	
AP 72			✓		✓	
AP 73	✓		✓		✓	
AP 193	✓				✓	✓
AP 196		✓			✓	✓
AP 197	✓	✓			✓	✓
AP 200			✓		✓	✓
AP 201	✓		✓		✓	✓



SUPPLY AHUS

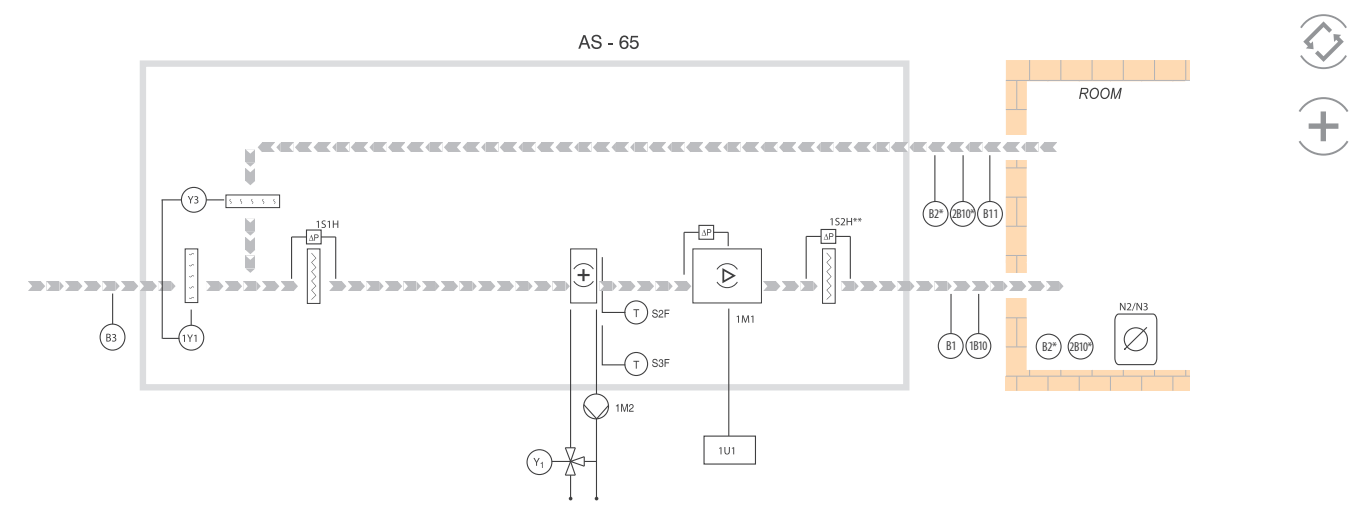
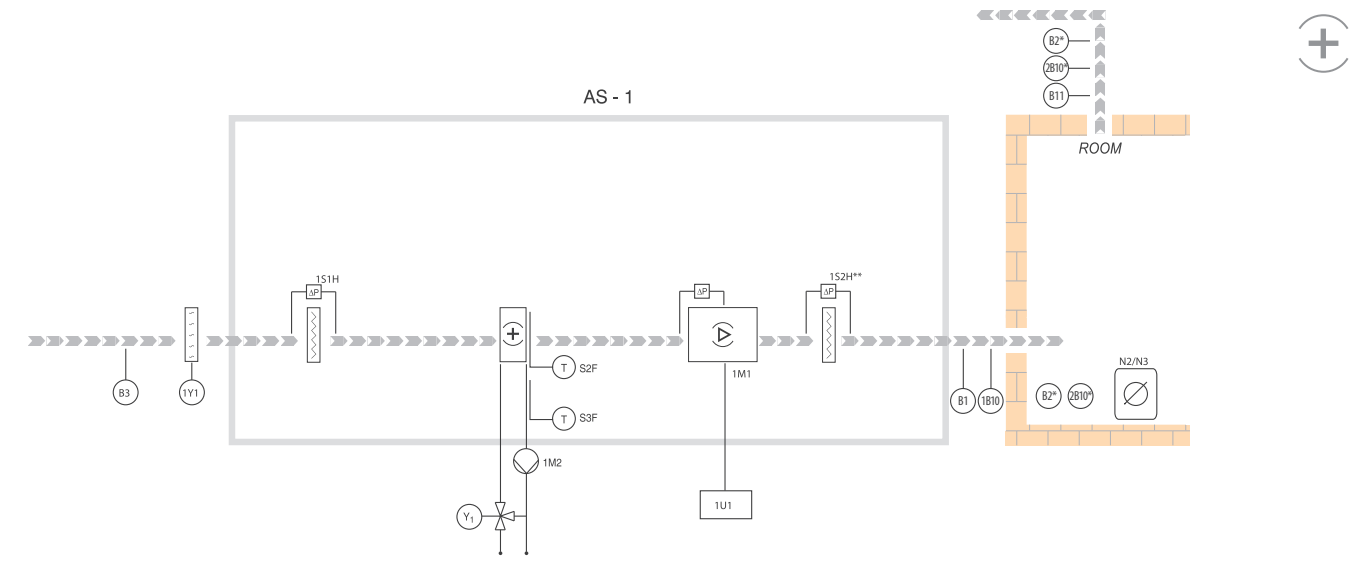

CONTROL

- » control of room temperature, or supply or exhaust air temperature
 - » control of the energy recovery level – first stage of heating/cooling
 - » air flow control
 - » operation according to calendar – temperature, efficiency, operation mode (OPERATION, STAND-BY, STOP)
 - » STAND-BY – maintaining the minimum, set indoor temperature.
- * Initial heating of external air

INFORMATION

- » information on outdoor, supply, exhaust and indoor air temperatures
- » filter contamination info
- » alarm status info
- » analog and digital input and output status info

PROTECTION

- » limiting the allowed supply air temperature
- » fan unit protection – the function is active: - if an electric heater is present
- » overload protection of a drive unit
- » anti-frost protection of a water heater
- » protection against overheating of an electric heater
- » optional protection against minimal and maximal temperature of medium returning from the water heater with use of Strap-on temperature sensor, standard NTC 10K
- » the control application layouts have been prepared on the basis of water exchangers
- » the quantity of applied pressure switches for filters depends on the filter configuration

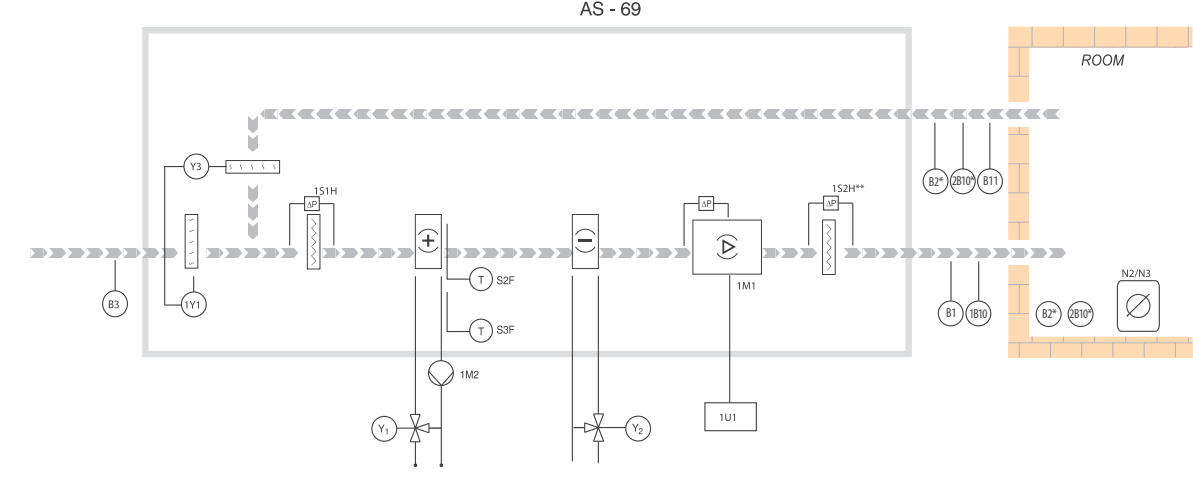
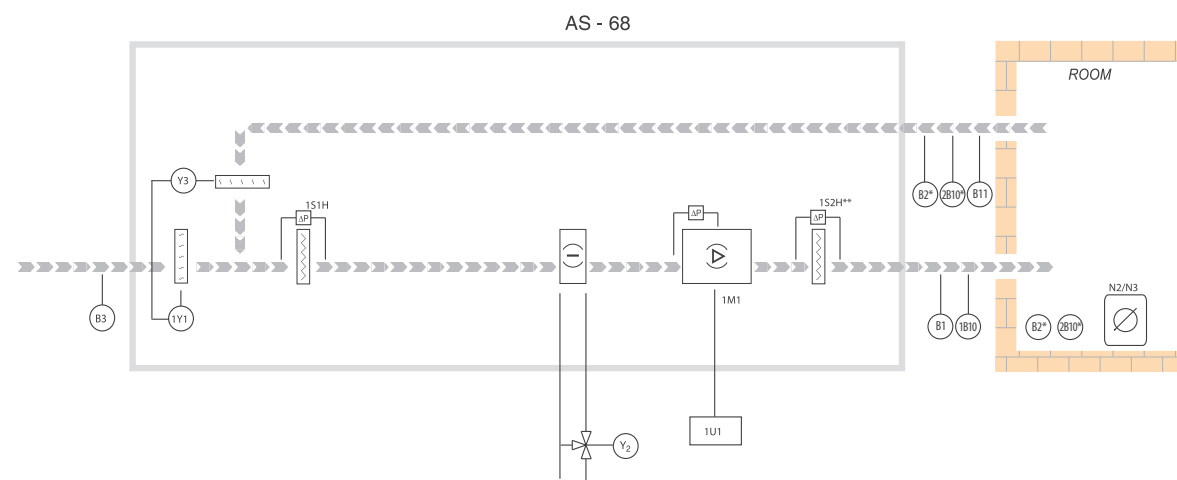
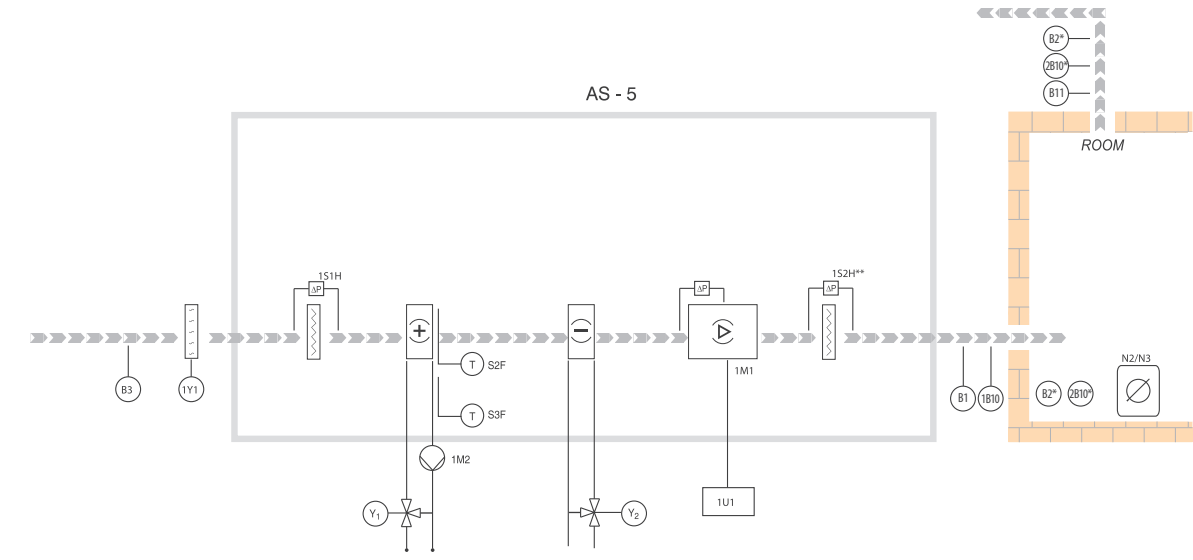
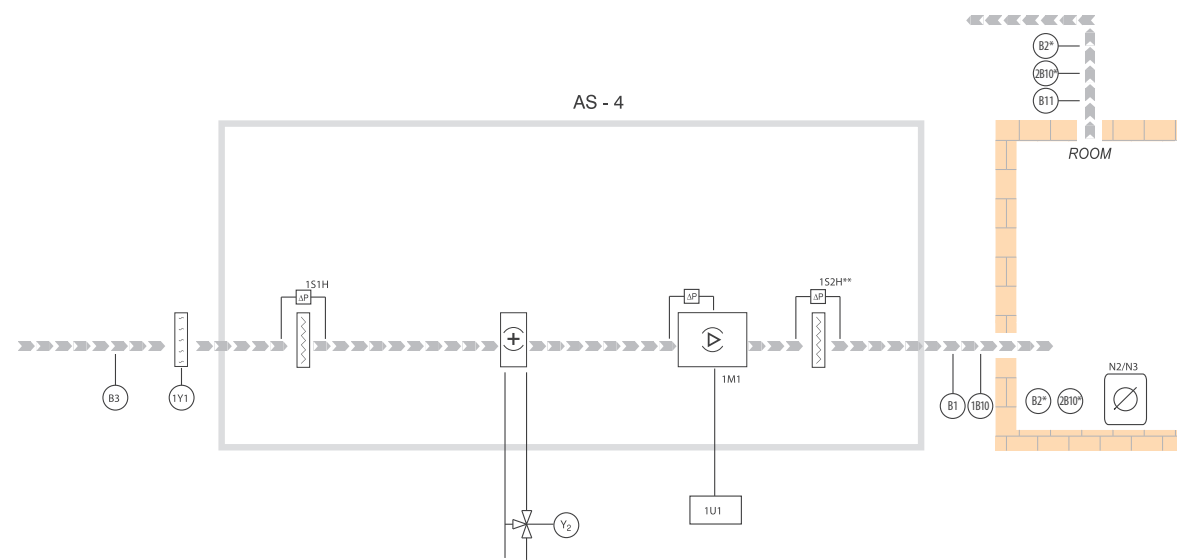

CONTROL

- » control of room temperature, optionally supply or exhaust air temperature
 - » control of the energy recovery level – first stage of heating/cooling
 - » air flow control
 - » operation according to calendar – temperature, efficiency, operation mode (OPERATION, STAND-BY, STOP)
 - » STAND-BY – maintaining the minimum, set indoor temperature.
- * Initial heating of external air.

INFORMATION

- » information on outdoor, supply, exhaust and indoor air temperatures
- » filter contamination info
- » alarm status info
- » analog and digital input and output status info

PROTECTION

- » limiting the allowed supply air temperature
- » fan unit protection – the function is active:
 - if an electric heater is applied
- » overload protection of a drive unit
- » anti-frost protection of a water heater
- » protection against overheating of an electric heater
- » the control application layouts have been prepared on the basis of water exchangers
- » the quantity of applied pressure switches for filters depends on the filters' configuration

CONTROL

- » control of room temperature, optionally supply or exhaust air temperature
 - » control of the energy recovery level – first stage of heating/cooling
 - » air flow control
 - » operation according to calendar – temperature, efficiency, operation mode (OPERATION, STAND-BY, STOP)
 - » STAND-BY – maintaining the minimum, set indoor temperature.
- * Initial heating of external air.

INFORMATION

- » information on outdoor, supply, exhaust and indoor air temperatures
- » filter contamination info
- » alarm status info
- » analog and digital input and output status info

PROTECTION

- » limiting the allowed supply air temperature
- » fan unit protection – the function is active:
 - if an electric heater is applied
- » overload protection of a drive unit
- » anti-frost protection of a water heater
- » protection against overheating of an electric heater.
- » the control application layouts have been prepared on the basis of water exchangers
- » the quantity of applied pressure switches for filters depends on the filters' configuration

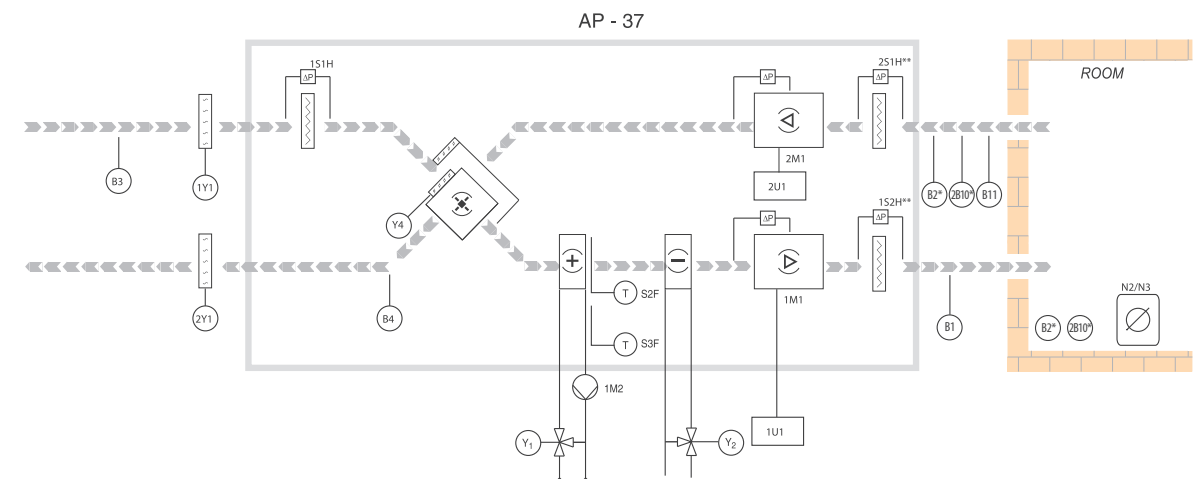
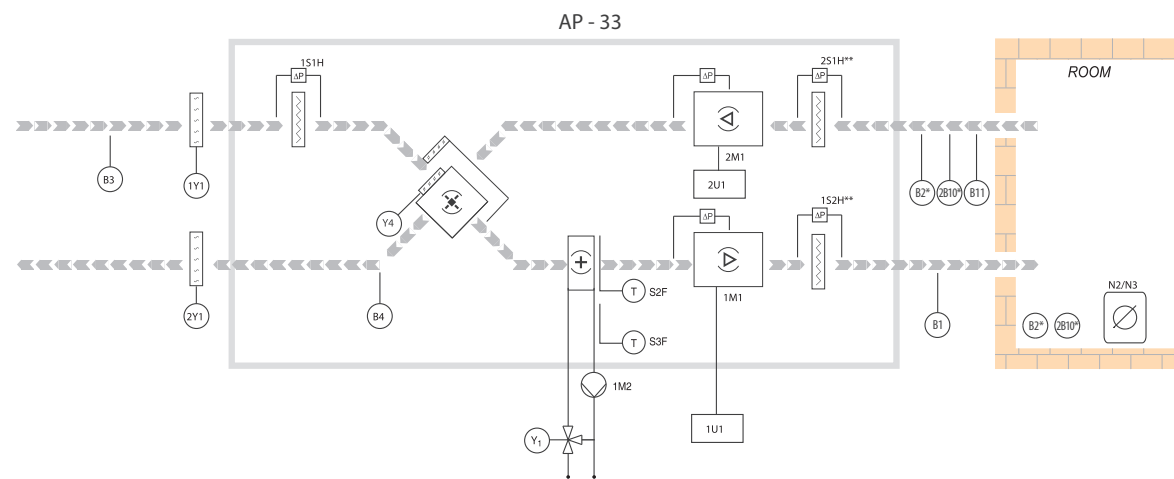
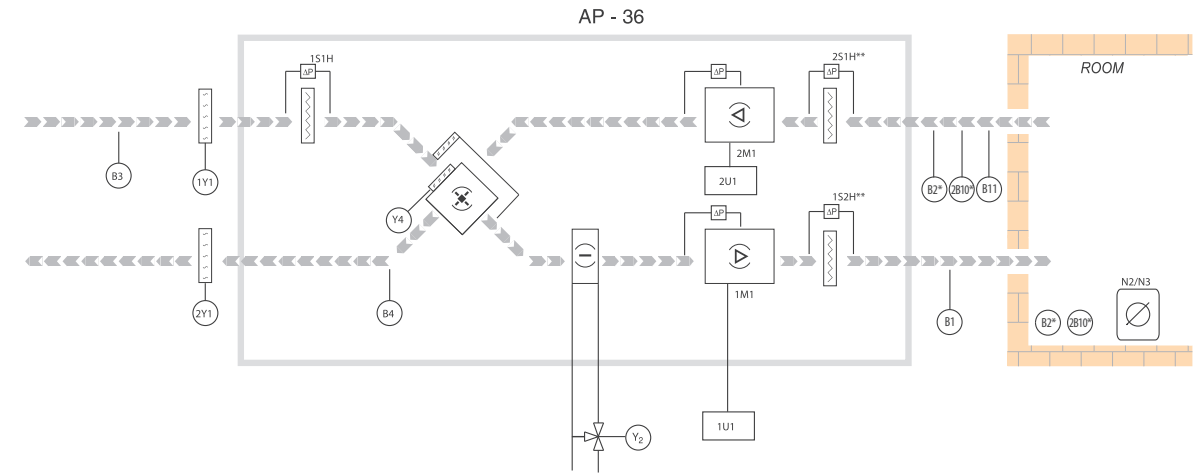
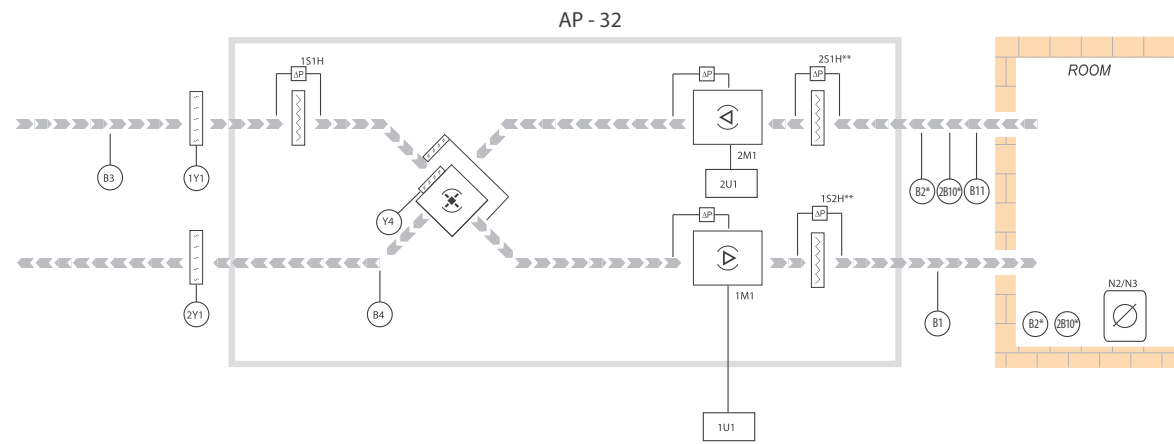

CONTROL

- » control of room temperature, optionally supply or exhaust air temperature
 - » control of the energy recovery level – first stage of heating/cooling
 - » air flow control
 - » operation according to calendar – temperature, efficiency, operation mode (OPERATION, STAND-BY, STOP)
 - » STAND-BY – maintaining the minimum, set indoor temperature
- * Initial heating of external air.

INFORMATION

- » information on outdoor, supply, exhaust and indoor air temperatures
- » filter contamination info
- » alarm status info
- » analog and digital input and output status info

PROTECTION

- » limiting the allowed supply air temperature
- » fan unit protection – the function is active:
 - if an electric heater is applied
- » overload protection of drive unit
- » anti-frost protection of a water heater
- » protection against overheating of an electric heater
- » anti-frost protection of an energy recovery exchanger
- » optional protection against minimal and maximal temperature of medium returning from the water heater with use of Strap-on temperature sensor, standard NTC 10K
- » the control application layouts have been prepared on the basis of water exchangers
- » the quantity of applied pressure switches for filters depends on the filters' configuration
- » optional Strap-on temperature sensor is not a part of VTS offer

CONTROL

- » control of room temperature, optionally supply or exhaust air temperature
 - » control of the energy recovery level – first stage of heating/cooling
 - » air flow control
 - » operation according to calendar – temperature, efficiency, operation mode (OPERATION, STAND-BY, STOP)
 - » STAND-BY – maintaining the minimum, set indoor temperature
- * Initial heating of external air.

INFORMATION

- » information on outdoor, supply, exhaust and indoor air temperatures
- » filter contamination info
- » alarm status info
- » analog and digital input and output status info

PROTECTION

- » limiting the allowed supply air temperature
- » fan unit protection – the function is active:
 - if an electric heater is applied
- » overload protection of a drive unit
- » anti-frost protection of a water heater
- » protection against overheating of an electric heater
- » the control application layouts have been prepared on the basis of water exchangers
- » the quantity of applied pressure switches for filters depends on the filters' configuration

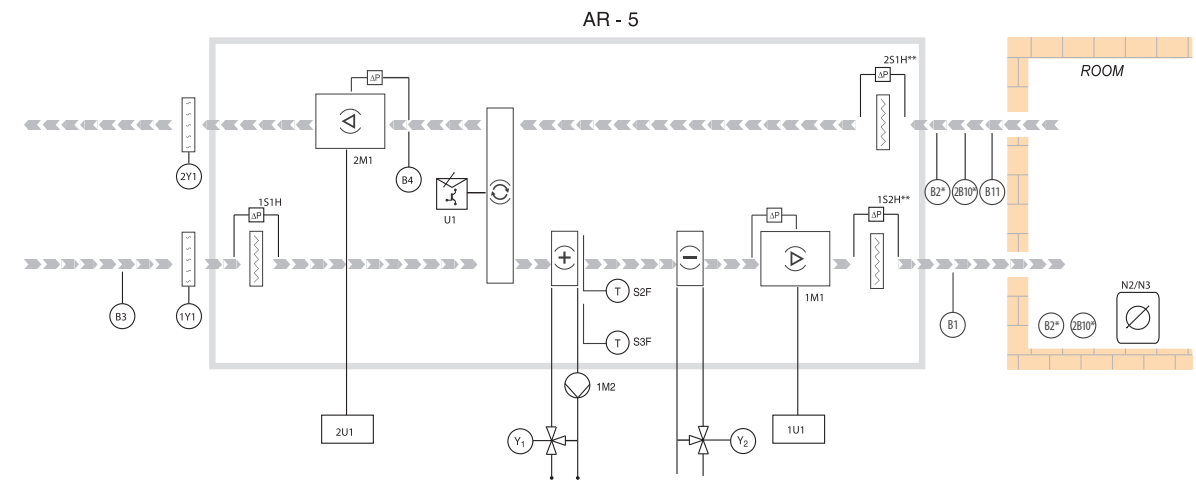
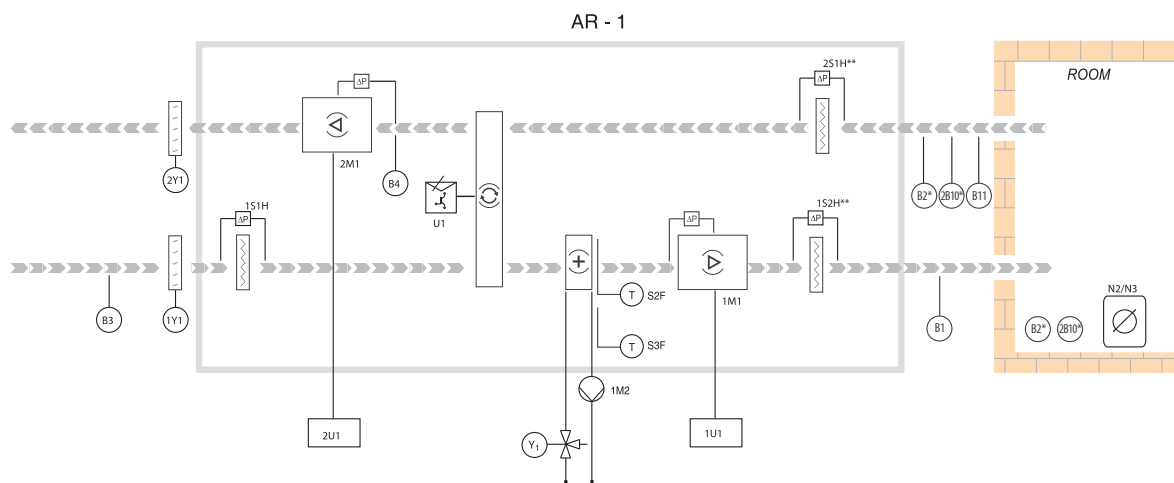
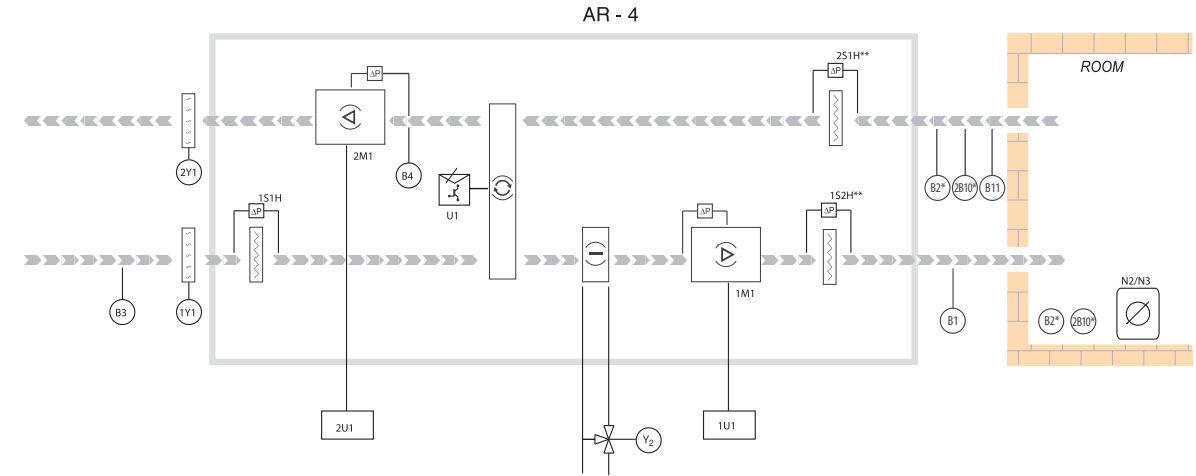
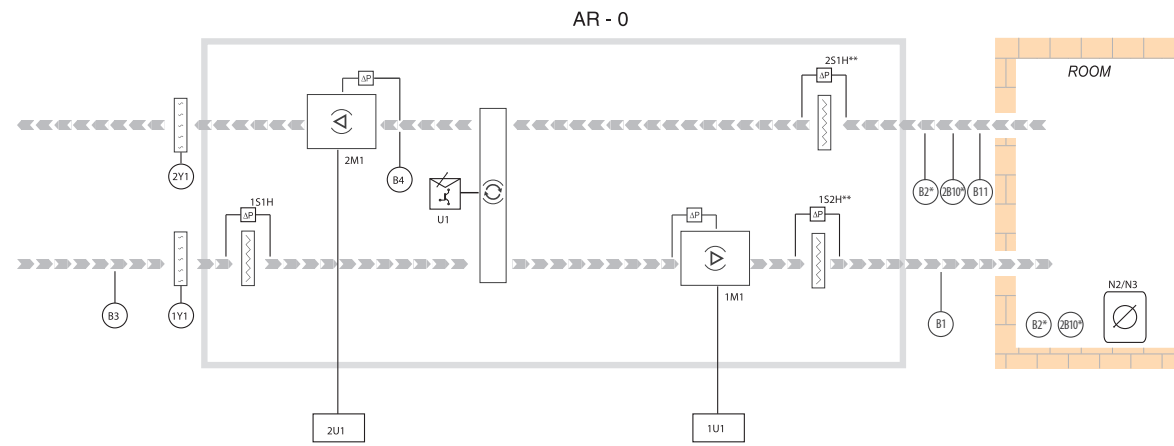

CONTROL

- » control of room temperature, optionally supply or exhaust air temperature
 - » control of the energy recovery level – first stage of heating/cooling
 - » air flow control
 - » operation according to calendar – temperature, efficiency, operation mode (OPERATION, STAND-BY, STOP)
 - » STAND-BY – maintaining the minimum, set indoor temperature
- * Initial heating of external air.

INFORMATION

- » information on outdoor, supply, exhaust and indoor air temperatures
- » filter contamination info
- » alarm status info
- » analog and digital input and output status info

PROTECTION

- » limiting the allowed supply air temperature
- » fan unit protection – the function is active:
 - if an electric heater is applied
- » overload protection of drive unit
- » anti-frost protection of a water heater
- » protection against overheating of an electric heater
- » anti-frost protection of an energy recovery exchanger
- » optional protection against minimal and maximal temperature of medium returning from the water heater with use of Strap-on temperature sensor, standard NTC 10K
- » the control application layouts have been prepared on the basis of water exchangers
- » the quantity of applied pressure switches for filters depends on the filters' configuration
- » optional Strap-on temperature sensor is not a part of VTS offer

CONTROL

- » control of room temperature, optionally supply or exhaust air temperature
 - » control of the energy recovery level – first stage of heating/cooling
 - » air flow control
 - » operation according to calendar – temperature, efficiency, operation mode (OPERATION, STAND-BY, STOP)
 - » STAND-BY – maintaining the minimum, set indoor temperature
- * Initial heating of external air.

INFORMATION

- » information on outdoor, supply, exhaust and indoor air temperatures
- » filter contamination info
- » alarm status info
- » analog and digital input and output status info

PROTECTION

- » limiting the allowed supply air temperature
- » fan unit protection – the function is active:
 - if an electric heater is applied
- » overload protection of a drive unit
- » anti-frost protection of a water heater
- » protection against overheating of an electric heater
- » anti-frost protection of an energy recovery exchanger
- » optional protection against minimal and maximal temperature of medium returning from the water heater with use of Strap-on temperature sensor, standard NTC 10K
- » the control application layouts have been prepared on the basis of water exchangers
- » the quantity of applied pressure switches for filters depends on the filters' configuration
- » optional Strap-on temperature sensor is not a part of VTS offer

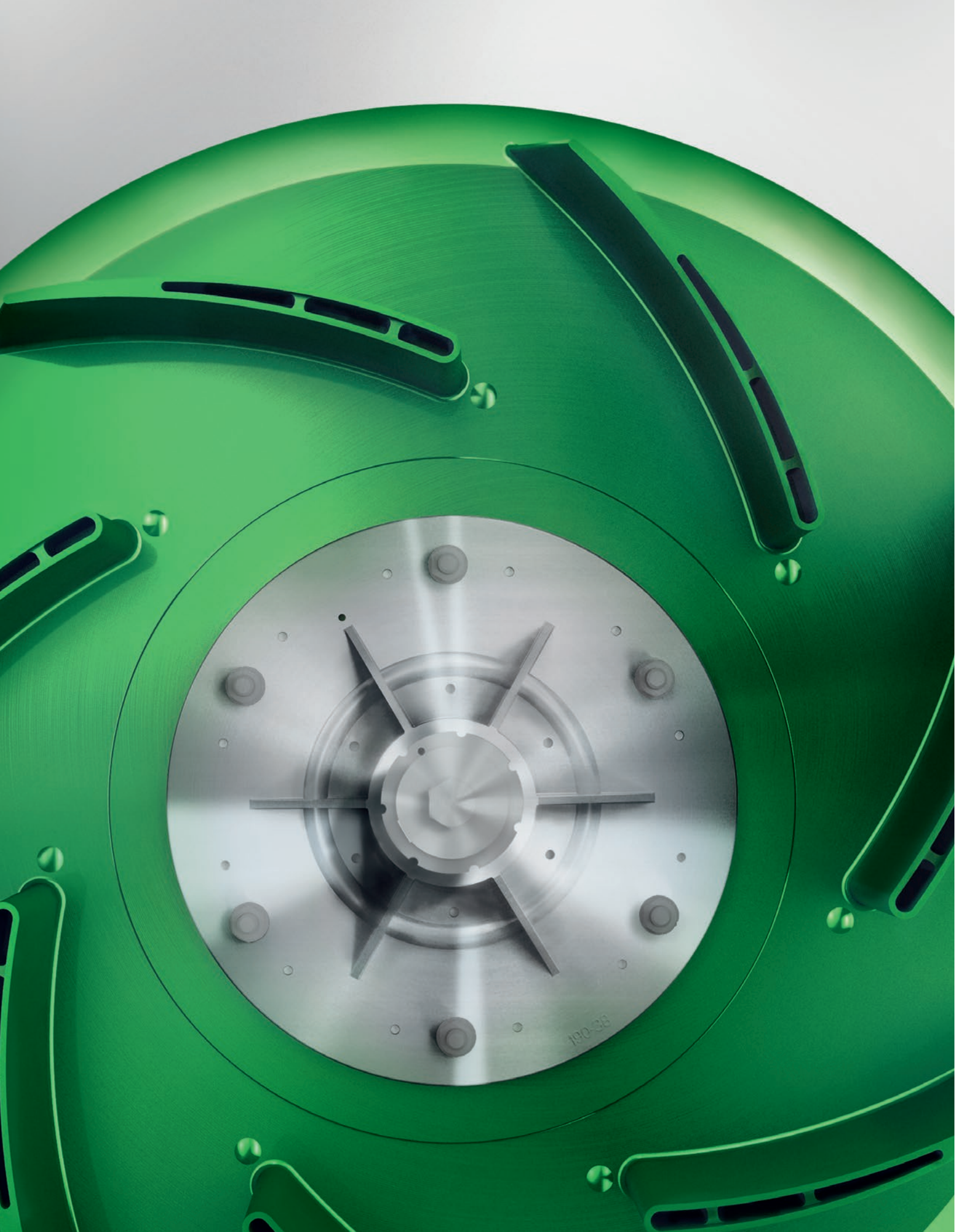

06

Functions



| Direct drive plenum fan

Energy efficient fans are based on single inlet, air foil backward curved radial impellers with 7 blades made of a composite material to minimize the impeller weight and provide the best operating performance and provide the best dynamically balanced operating performance.



VARIABLE FREQUENCY DRIVE [VFD]

The accurate selection of air flow design and external static pressure with a smooth regulation by proportional change of the motor-fan unit rotational speed. Protection of the maximum value of the motor current, the capability to be integrated with external analog and binary signals and the integration with the BMS system

PLENUM FAN MOTOR

Fans are driven by TEFC (Totally Enclosed Fan Cooled) foot mounted motors with double shielded bearings and range from 1 HP to 15 HP. Nominal frequency: 60 Hz. Insulation class: F. Efficiency class: Premium. Bearings live: $L_{10} = 20,000$ h, $L_{50} = 100,000$ h. Shaft grounding rings available (on request).

Fan sets used in submitted air handling units are available in a wide range of voltages: 115V/1PH/60Hz, 208V/ 1PH/60Hz, 230V/1PH/60Hz, 208V/3PH/60Hz, 230V/3PH/60Hz, 460V/3PH/60Hz, 575V/3PH.

AMCA



VTS Group certifies that the VS fan series shown herein are licensed to bear the AMCA Seal. The ratings shown are based on tests and procedures performed in accordance with AMCA Publication 211 and AMCA Publication 311 and comply with the requirements of the AMCA Certified Ratings Program. The certified ratings for the VS Fans are shown in this catalogue.



| Air-to-air energy recovery systems

AIR-TO-AIR ENERGY WHEEL

The total energy wheel is constructed with 7.9 inch Aluminum coated with non-toxic, non-corrosive Silica gel in a way that allows it to exchange sensible and latent heat between two airstreams, generally outside air and exhaust air. In the cooling mode, the wheel pre-treats the outside air by transferring sensible and latent heat to the exhaust stream. During the heating mode, the wheel pre-treats the outside air with sensible and latent heat from the exhaust air. This energy recovery is done without total separation of the supply and exhaust air flows with air leakages of 2% to 5%.

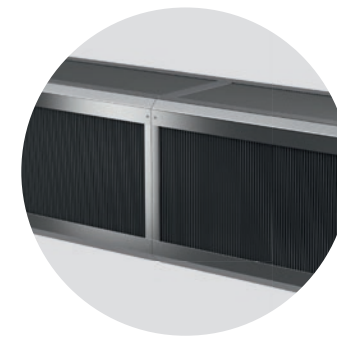

CROSS-FLOW PLATE

Cross-Flow plate is an indirect energy recovery device, that transfers heat from the exhaust air stream to the entering air stream which will be supplied to the space. Heat recovery at very high separation of the stream of supply and exhaust air (99.9%). Application in block supply-exhaust AHUs.



FLAT PREFILTER

All units have a two or four inches flat prefilter or a combination thereof

- MERV8 two-inch filter.
- MERV13 four-inch filter.



HEATERS

Heaters are available in the following versions:

- hot water heating coils,
- resistant electric heaters,
- DX heating coils.

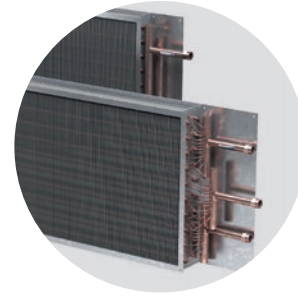
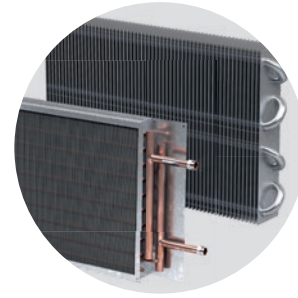

COOLING COILS

The cooling coils are available either as a hydronic or a DX cooling coils.

The variety of coil types allows a user to select a coil that is optimized for pressure drop and capacity requirements. The cooling coils are mounted over the drainpan to ensure water condensate flowing.

AIR DAMPERS

VTS Group certifies that the dampers shown herein are licensed to bear the AMCA Seal. The ratings shown are based on tests and procedures performed in accordance with AMCA Publication 511 and comply with the requirements of the AMCA Certified Ratings Program. The AMCA International Certified Ratings Seal applies to Air Performance and Air Leakage. The VTS air dampers are in 3-rd class for 1, 4 and 8 in. w.g.

Leakage testing conducted in accordance with AMCA Standard 500-D-07 figure 5.4 Alternate. Data are based on a torque of 10 in-lb/ft2 applied to close and seal the damper during the test. Air leakage is based on operation between 32 to 120 F. All data corrected to represent standard air density 0.075 lb/ft3.

Pressure drop testing conducted in accordance with AMCA Standard 500-D-07 figure 5.3. All data corrected to represent standard air density 0.075 lb/ft3.

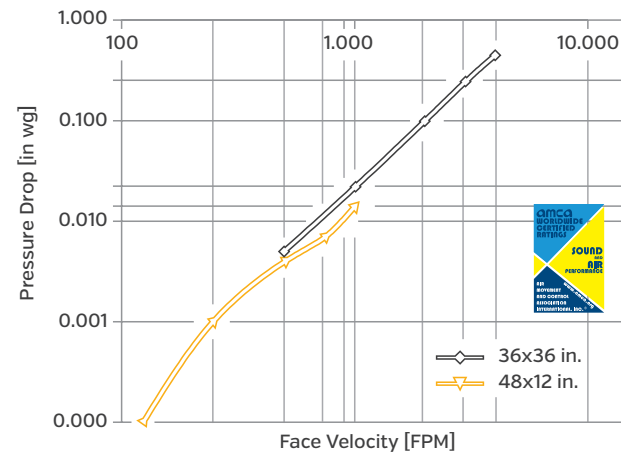
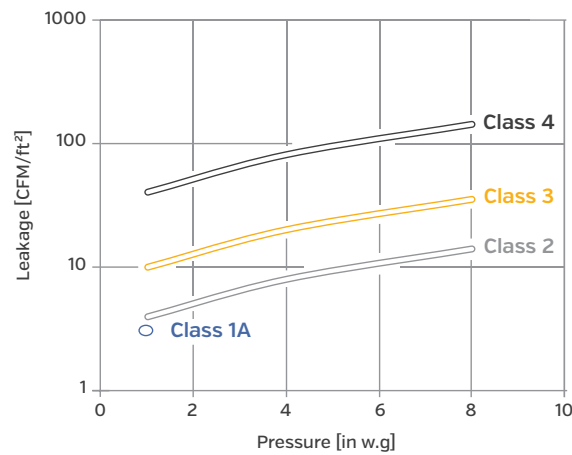

PSYCHROMETRIC CHART

Normal Temperature
Barometric Pressure: 29.921 Inches of Mercury
Sea Level

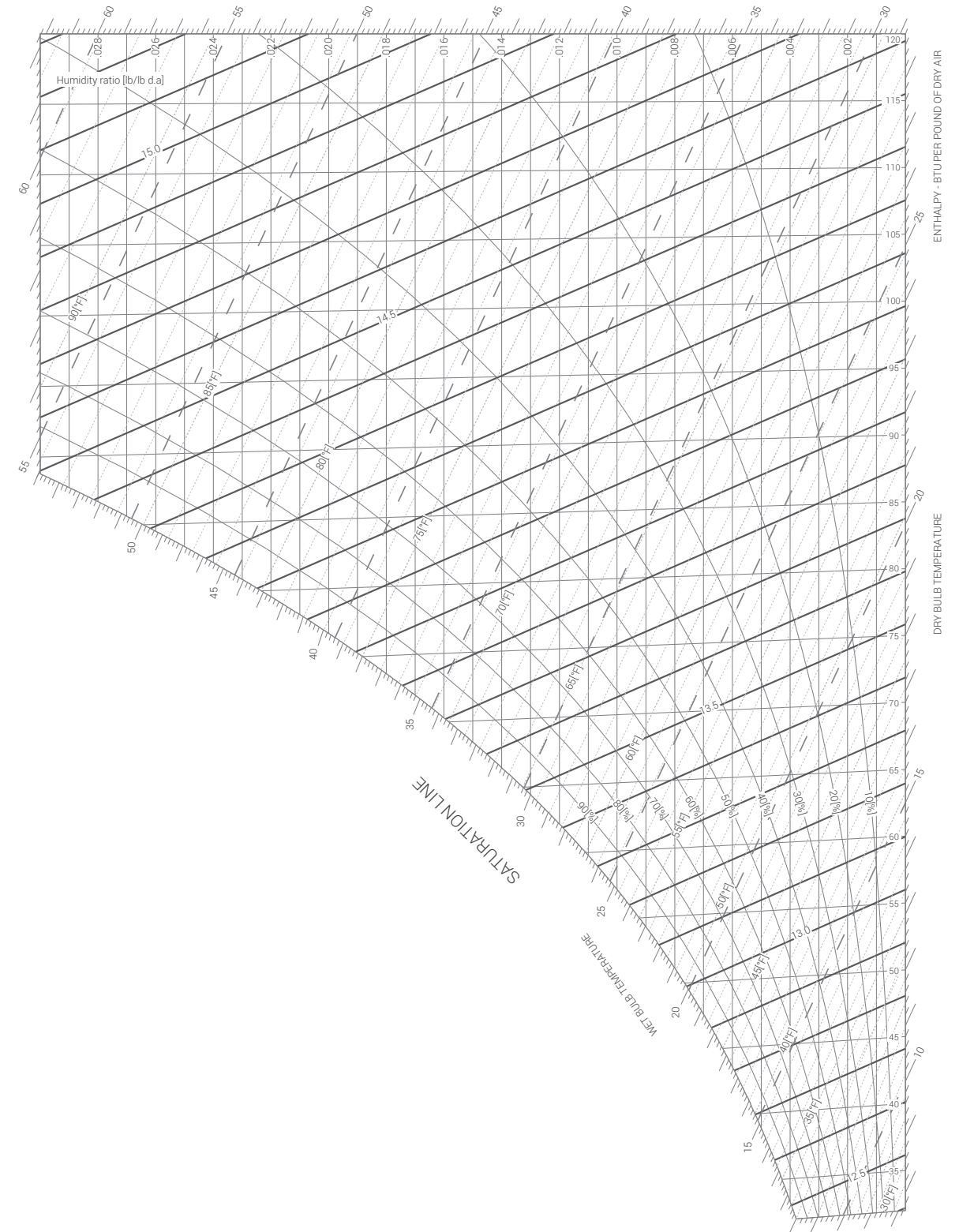



Certified fan performance data for fans of LDX 225 - LDX 400 sizes



Unit Size	Q (cfm)	Ps (in. wg)	BHP (hp)
LDX-225 4000 RPM	1204	0,00	0,620
	1123	0,74	0,664
	1038	1,47	0,718
	973	1,90	0,753
	848	2,62	0,804
	784	2,92	0,819
	687	3,25	0,813
	602	3,53	0,801
	525	3,72	0,784
	347	4,16	0,719
0	4,78	0,467	
LDX-250 3900 RPM	1822	0,00	1,045
	1685	1,01	1,175
	1557	1,84	1,249
	1460	2,54	1,321
	1365	3,07	1,392
	1303	3,38	1,412
	1259	3,59	1,431
	1172	3,93	1,443
	996	4,49	1,420
	820	4,68	1,312
0	5,95	0,685	
LDX-315 3250 RPM	3036	0,00	1,360
	2854	0,67	1,537
	2666	1,54	1,742
	2492	2,40	1,922
	2244	3,27	2,131
	2002	3,90	2,235
	1752	4,42	2,258
	1574	4,69	2,212
	1360	5,03	2,126
	913	5,44	1,812
0	6,16	0,912	
LDX-355 3200 RPM	4102	0,00	2,487
	3700	1,68	2,989
	3318	3,25	3,382
	2841	4,63	3,714
	2496	5,36	3,806
	2079	6,02	3,710
	1655	6,48	3,478
	1146	6,90	3,020
	990	7,01	2,922
	744	7,11	2,704
0	7,56	1,723	
LDX-400 2950 RPM	4992	0,00	2,830
	4481	1,92	3,554
	4020	3,46	4,144
	3496	4,95	4,627
	3007	5,93	4,761
	2449	6,53	4,559
	2119	6,89	4,372
	1593	7,31	3,956
	1098	7,61	3,460
	786	7,75	3,138
0	8,24	2,093	

NOTE 1: Performance certified is for installation Type A, Free Inlet, Free Outlet. Power rating (BHP) does not include transmission losses. Performance ratings do not include the effects of appurtenances (accessories).

NOTE 2: Efficiency ratings are fan static and exclude bearing and/or Power Transmission Losses.

NOTE 3: VTS America Inc. certifies that the Model VS shown herein is licensed to bear the AMCA Seal. The ratings shown are based on tests and procedures performed in accordance with AMCA Publication 211 and AMCA Publication 311 and comply with the requirements of the AMCA Certified Ratings Program.



Certified fan performance data for fans of LDX 450 - LDX 630 sizes



Unit Size	Q (cfm)	Ps (in. wg)	BHP (hp)
LDX-450 2900 RPM	6780	0,00	4,653
	6124	1,94	5,807
	5382	4,13	6,973
	4746	5,86	7,818
	4132	7,08	8,153
	3496	7,97	8,060
	3030	8,37	7,671
	2712	8,58	7,335
	2458	8,75	7,067
	1377	9,30	5,833
0	10,11	3,406	
LDX-500 2400 RPM	8086	0,00	4,697
	7289	1,65	5,474
	6344	3,71	6,761
	5687	4,91	7,457
	4873	6,01	7,910
	4098	6,81	7,818
	3225	7,32	7,159
	2585	7,60	6,603
	1939	7,81	5,914
	1235	7,95	5,105
0	8,51	3,110	
LDX-560 2100 RPM	10302	0,00	6,050
	9274	1,57	6,938
	8304	3,19	7,979
	7238	4,70	8,971
	6346	5,64	9,321
	5215	6,65	9,419
	4257	7,14	8,855
	3096	7,49	7,760
	2248	7,63	6,866
	1307	7,72	5,799
0	8,20	3,647	
LDX-630 1750 RPM	11942	0,00	6,949
	10783	1,49	8,085
	9696	2,93	9,211
	8425	4,39	10,270
	7117	5,48	10,511
	5865	6,24	10,121
	4770	6,71	9,504
	3598	6,94	8,522
	2466	7,07	7,473
	1329	7,14	6,192
0	7,41	4,359	

NOTE 1: Performance certified is for installation Type A, Free Inlet, Free Outlet. Power rating (BHP) does not include transmission losses. Performance ratings do not include the effects of appurtenances (accessories).

NOTE 2: Efficiency ratings are fan static and exclude bearing and/or Power Transmission Losses.

NOTE 3: VTS America Inc. certifies that the Model VS shown herein is licensed to bear the AMCA Seal. The ratings shown are based on tests and procedures performed in accordance with AMCA Publication 211 and AMCA Publication 311 and comply with the requirements of the AMCA Certified Ratings Program.



Certified sound pressure level for fans of LDX 225 - LDX 400 sizes



Unit Size	Ps (in. wg)	Q (cfm)	Lw Loudness	63 Hz	125 Hz	250 Hz	500 Hz	1 kHz	2 kHz	4 kHz	8 kHz	Lw(A) dB(A)	Loudness Sones
LDX-225 4000 RPM	0,74	1123	dB	101,6	83,9	85,4	79,8	77,7	73,5	73,1	75,1	84	48,6
			Sones	164,8	48,3	53,6	36,3	31,4	23,5	22,8	26,2		
	2,62	848	dB	109,5	75,2	72,8	76,0	75,3	70,4	70,0	66,2	85	52,1
			Sones	285,0	26,4	22,4	27,9	26,6	18,9	18,4	14,1		
	3,53	602	dB	110,2	75,5	76,5	77,4	75,6	70,0	69,1	64,6	85	52,1
			Sones	299,2	27,0	28,9	30,8	27,1	18,4	17,3	12,7		
4,78	0	dB	112,0	82,0	84,7	80,9	78,6	72,7	71,7	66,0	88	64,2	
		Sones	338,9	42,3	51,0	39,2	33,4	22,2	20,7	14,0			
LDX-250 3900 RPM	1,01	1685	dB	109,9	77,8	83,4	80,3	77,3	73,7	76,2	85,3	89	68,8
			Sones	293,0	31,6	46,6	37,6	30,5	23,8	28,3	53,2		
	3,07	1365	dB	105,4	77,8	78,7	78,3	76,5	72,5	81,1	78	86	55,8
			Sones	214,4	31,6	33,7	32,7	28,9	21,9	39,8	32,1		
	3,93	1172	dB	101,4	76,3	79,4	75,5	74,4	72	77,1	71,1	83	45,4
			Sones	162,5	28,5	35,3	27,0	25,0	21,1	30,1	19,9		
5,95	0	dB	99,7	83,2	88	83,6	79,9	74	73,3	68,6	86	55,8	
		Sones	144,4	46,0	64,2	47,3	36,6	24,3	23,1	16,7			
LDX-315 3250 RPM	0,67	2854	dB	107,3	83,6	81,7	82,5	75,8	76,3	80,6	80,3	88	64,2
			Sones	244,7	47,3	41,4	43,8	27,5	28,5	38,4	37,6		
	3,27	2244	dB	106,1	78,6	80,9	79,1	72,9	73,7	73,7	73,1	84	48,6
			Sones	225,1	33,4	39,2	34,6	22,5	23,8	23,8	22,8		
	4,69	1574	dB	105,2	81	82,9	81,4	73,6	74,2	72,8	68,9	84	48,6
			Sones	211,5	39,5	45,0	40,6	23,6	24,6	22,4	17,1		
6,16	0	dB	106,4	87,4	88	85,7	79,8	76,9	74,8	70	88	64,2	
		Sones	229,9	61,5	64,2	54,7	36,3	29,7	25,7	18,4			
LDX-355 3 200 RPM	1,68	3700	dB	107,8	79,6	85	83,5	80,1	85,9	89,7	79,1	93	90,7
			Sones	253,3	35,8	52,1	47,0	37,1	55,5	72,2	34,6		
	5,36	2496	dB	104,9	79,8	80,5	80,7	77,4	85,5	87,1	75,7	91	79,0
			Sones	207,1	36,3	38,1	38,7	30,8	53,9	60,3	27,3		
	6,90	1146	dB	103,9	92,5	97,3	89,6	81,8	85,8	87	74,9	94	97,3
			Sones	193,3	87,7	122,3	71,7	41,7	55,1	59,9	25,9		
7,56	0	dB	102,3	89,4	91,6	89,8	83,9	85,5	86,6	74,6	93	90,7	
		Sones	173,0	70,7	82,3	72,7	48,3	53,9	58,2	25,3			
LDX-400 2950 RPM	1,92	4481	dB	96,3	85	92,8	90,2	86,9	86,8	91,5	86,3	96	111,7
			Sones	114,1	52,1	89,5	74,7	59,4	59,0	81,8	57,0		
	5,93	3007	dB	98,2	79,7	86,4	84,1	80,8	82	82,9	84,8	90	73,7
			Sones	130,2	36,1	57,4	49,0	38,9	42,3	45,0	51,4		
	7,31	1593	dB	100,2	93,1	99,7	90,6	82,7	81,9	82,4	83,3	94	97,3
			Sones	149,5	91,4	144,4	76,8	44,4	42,0	43,5	46,3		
8,24	0	dB	98,9	89,9	94,2	90,3	84,6	83,3	81,3	77,6	92	84,7	
		Sones	136,6	73,2	98,6	75,2	50,7	46,3	40,3	31,2			

NOTE 1: The sound power level ratings shown are in decibels, referred to 10-12 watts, calculated per AMCA Standard 301. Values shown are for outlet LwA sound power levels and outlet hemispherical sone levels for installation type A:Free Inlet, Free Outlet, calculated per AMCA Standard 301. The AMCA Certified Ratings Seal applies to Air performance and sound.

NOTE 2 VTS America Inc. certifies that the Model VS shown herein is licensed to bear the AMCA Seal. The ratings shown are based on tests and procedures performed in accordance with AMCA Publication 211 and AMCA Publication 311 and comply with the requirements of the AMCA Certified Ratings Program.*

Certified sound pressure level for fans of LDX 450 - LDX 630 sizes



Unit Size	Ps (in. wg)	Q (cfm)	Lw Loudness	63 Hz	125 Hz	250 Hz	500 Hz	1 kHz	2 kHz	4 kHz	8 kHz	Lw(A) dB(A)	Loudness Sones
LDX-450 2900 RPM	1,94	6124	dB	117	94	97	94	92	92	95	85	100	147,5
			Sones	479,4	97,3	119,8	97,3	84,7	84,7	104,2	52,1		
	7,08	4132	dB	101	96	92	88	88	88	86	82	94	97,3
			Sones	158,1	111,7	84,7	64,2	64,2	64,2	55,8	42,3		
	8,58	2712	dB	103	100	98	90	86	87	84	80	95	104,2
			Sones	181,6	147,5	128,4	73,7	55,8	59,9	48,6	36,8		
10,11	0	dB	107	102	97	93	89	87	83	79	96	111,7	
		Sones	239,6	169,4	119,8	90,7	68,8	59,9	45,4	34,4			
LDX-500 2400 RPM	1,65	7289	dB	88,8	87,4	92	90	88,1	88,2	92,5	82	97	119,8
			Sones	67,8	61,5	84,7	73,7	64,6	65,1	87,7	42,3		
	6,01	4873	dB	84,8	79,2	89,3	84	84,2	85,4	82,7	77,9	91	79,0
			Sones	51,4	34,8	70,2	48,6	49,3	53,6	44,4	31,8		
	7,60	2585	dB	100,2	93,7	96,8	88,6	84,6	85,2	81,6	76,9	93	90,7
			Sones	149,5	95,3	118,1	66,9	50,7	52,8	41,2	29,7		
8,51	0	dB	95,5	93,5	95,7	90,3	85,4	83,1	79	75	93	90,7	
		Sones	107,9	93,9	109,4	75,2	53,6	45,7	34,4	26,0			
LDX-560 2100 RPM	1,57	9274	dB	89,1	89,1	94,2	90	89,7	90,9	93,1	82,8	98	128,4
			Sones	69,2	69,2	98,6	73,7	72,2	78,4	91,4	44,7		
	5,64	6346	dB	86,8	83,7	88,5	86,5	86,4	85,8	83,9	79,4	92	84,7
			Sones	59,0	47,6	66,4	57,8	57,4	55,1	48,3	35,3		
	7,49	3096	dB	98,2	98,6	94,8	88,2	86,7	85,4	81,8	77,5	93	90,7
			Sones	130,2	133,8	102,8	65,1	58,6	53,6	41,7	31,0		
8,20	0	dB	93,6	95,3	94,8	89,2	85,2	81,5	77,5	74	92	84,7	
		Sones	94,6	106,4	102,8	69,7	52,8	40,9	31,0	24,3			
LDX-630 1750 RPM	1,49	10783	dB	96,9	94,1	96,1	92,5	91	90	89,4	83,6	97	119,8
			Sones	118,9	97,9	112,5	87,7	79,0	73,7	70,7	47,3		
	5,48	7117	dB	105,6	91,5	93	88,8	88,1	85,5	82,9	79,4	93	90,7
			Sones	217,4	81,8	90,7	67,8	64,6	53,9	45,0	35,3		
	6,94	3598	dB	104,5	98,9	94,7	88,9	88	85,4	82,2	78,5	94	97,3
			Sones	201,5	136,6	102,1	68,3	64,2	53,6	42,9	33,2		
7,41	0	dB	102,8	96,4	95,6	90,3	87	83,3	79,2	75,5	93	90,7	
		Sones	179,1	114,9	108,7	75,2	59,9	46,3	34,8	27,0			

NOTE 1: The sound power level ratings shown are in decibels, referred to 10-12 watts, calculated per AMCA Standard 301. Values shown are for outlet LwA sound power levels and outlet hemispherical sone levels for installation type A:Free Inlet, Free Outlet, calculated per AMCA Standard 301. The AMCA Certified Ratings Seal applies to Air performance and sound.

NOTE 2 VTS America Inc. certifies that the Model VS shown herein is licensed to bear the AMCA Seal. The ratings shown are based on tests and procedures performed in accordance with AMCA Publication 211 and AMCA Publication 311 and comply with the requirements of the AMCA Certified Ratings Program.*



SYMBOLS AND LABELS

Basic symbols

PROCESS			FUNCTION
Symbol	Graphic	Name	Options of functions
F		AIR FILTRATION	FILTER
V		VENTILATION	FAN
C		AIR COOLING	HYDRONIC COOLING COIL DX COOLING COIL RUN-AROUND COIL
H		AIR HEATING	HYDRONIC HEATING COIL ELECTRIC HEATER DX HEATING STEAM HEATER RUN-AROUND COIL
M		MIXING BOX	MIXING BOX
P		ENERGY RECOVERY	CROSS FLOW PLATE
R		ENERGY RECOVERY	ENERGY WHEEL

Auxiliary symbols

Symbol	Graphic	Name
FC		FLEXIBLE CONNECTION
AD		DAMPER
FLG		FLANGES
E		EMPTY SECTION



VTS America, Inc.

3535 Gravel Springs Road Ext
Suite 201

Buford, GA 30519

United States of America

Tel: 470-809-6811

Fax: 470-809-6815

e-mail: america@vtsgroup.com

Catalog Version: January, 2025

The features mentioned are subject to continuous upgrade and can change any time.
VTS assuring continuous improvement for product and data and reserves the right to change design and specifications without notice.

www.vtsgroup.com