



Dustech Engineers Private Limited certifies that the DOFA Series Axial Flow Fan shown herein is licensed to bear the AMCA Seal. The ratings shown are based on tests and procedures performed in accordance with AMCA Publication 211 and AMCA Publication 311 and comply with the requirements of the AMCA Certified Ratings Program.

DUSTECH



DOFA Series Axial Flow FAN



Application

DUSTECH fans are true axial fans designed for a wide range of commercial and industrial applications. High pressure efficiency permits the fans to be installed anywhere in the system - in any position. The fans can be used for either supply or exhaust by simply turning the entire unit to move air in the desired direction.

DUSTECH fans are extremely compact and well suited to locations where space is limited, and can often be easily mounted directly to the ductwork. As a result of very close tolerances and carefully matched vanes and rotors, DUSTECH fans offer exceptional performance across their size ranges.

Motors

Totally enclosed motors are standard. Several alternatives, such as explosion proof or two-speed motors, are available to fit your specific needs. Only nationally recognized brand motors with nationwide service facilities are used.

Contact your Dustech representative for more information. Totally enclosed, single phase motors have built-in overload protection.

Finish

Parts requiring painting are processed through the advanced Dustech multi-stage pretreatment system prior to the application of any coatings to ensure maximum finish adhesion. These parts are then powder coated with epoxy to provide a protective coating rated excellent for hardness, impact resistance, adhesion and chemical resistance.



SPECIFICATIONS DUSTECH Axial fans shall be Direct Driven with the motor located downstream from the impeller. Impeller blades are to be made of a high strength, corrosion resistant, aluminium alloy. Blades are to be die cast for maximum efficiency and low noise levels. The impeller hubs are to be die-formed of Cast Iron with angle location marks to allow accurate blade setting at the factory or in the field. The impeller is to be statically and dynamically balanced. Fan housings shall be constructed of heavy gauge steel with integral prepunched flanges for leak-free performance. High efficiency, straightening vanes, guard, silencer, damper and cowl are optional accessories.

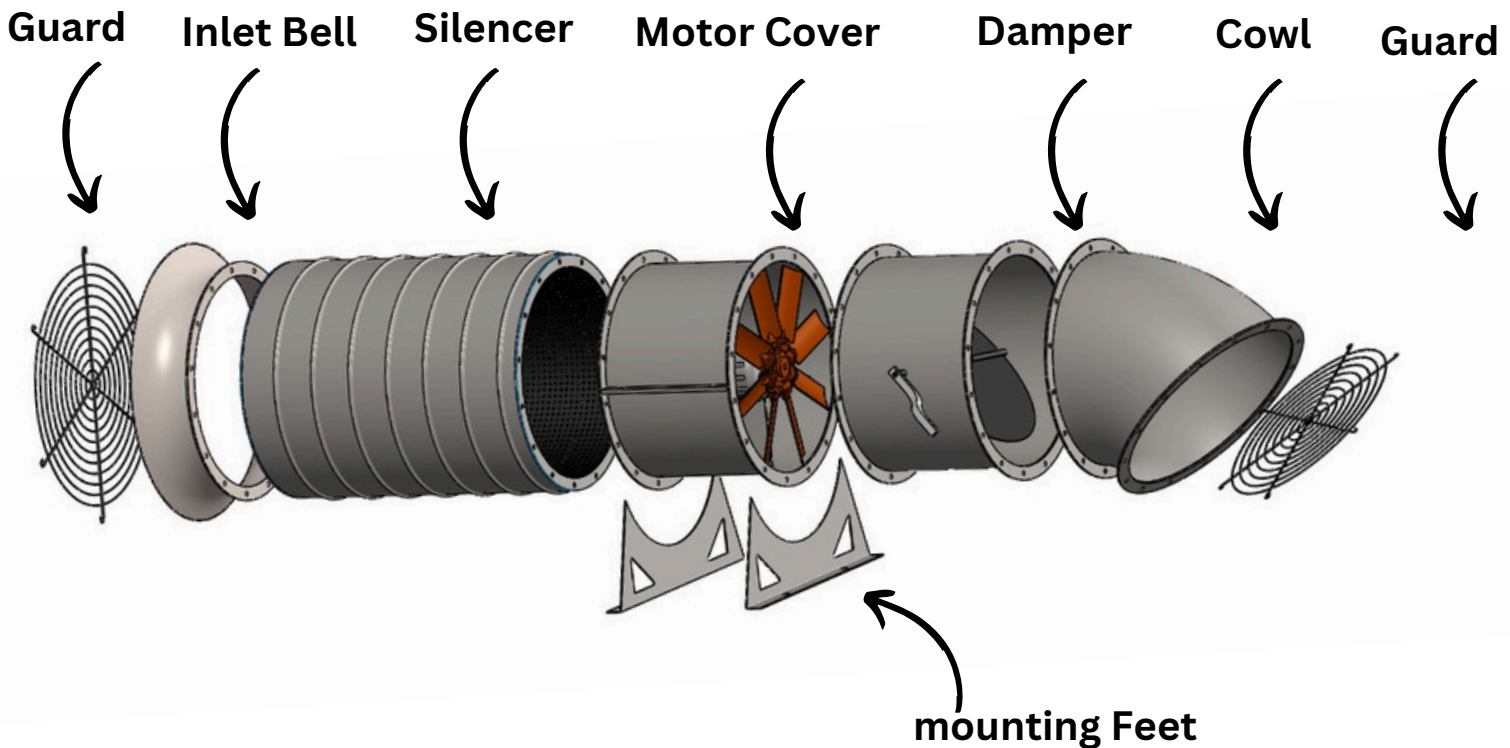

DOFA Series Axial Flow FAN

Options and Accessories

Inlet Bell:-

For a DUSTECH fan that is not duct connected at the inlet, an inlet bell is recommended for efficient performance.

Inlet\Outlet Guard:-

Guards prevent the entry of foreign material into the fan. Guards can be mounted on either the fan inlet or outlet.

Silencer:

Counter Flange The Counter flange - a flange identical to the fan flange is designed to be attached to the adjoining duct to simplify fan installation. **Duct Connector** A duct connector is available for ease in mating the DUSTECH fan to ductwork. **Access DOOR** This removable panel allows limited access to fan for inspection and cleaning of fan interior, and lubrication of direct drive motors **Protective Coatings** Ventilator units are not recommended for exhausting air of a corrosive nature. However, special protective Coatings are available where units may be exposed to corrosive exterior conditions. Parts requiring painting are processed through DUSTECH multistage pretreatment system prior to the application of any coatings to insure maximum finish adhesion. These parts use a thermosetting epoxy powder paint To a smooth, hard continuous finish. For applications that require more specialized surface protection, DUSTECH offers alternatives: epoxy or hot dip galvanizing, and others. For more information about special protective coatings, contact DUSTECH representative.

Motor Cover :-

The painted steel housing encloses motor.

Mounting Feet :- When necessary to support fan weight from floor or ceiling, mounting feet should be specified. Applications which involve wall mounting should be referred to your DUSTECH representative for recommended Type of support to which fan will be mounted and location relative to motor (or access DOOR) should be clearly stated. Special Motors Two-speed, Energy efficient, emergency motor, explosion- proof Motors for hazardous locations may be available in many models.

DAMPER :- Dustech Damper are used in axial flow fans to control the flow of air without changing the speed of the fan. damper prevents the air flow if the system is non operational. Dustech Dampers can be used energy saving, when the air flow needs to be Modulated or run at a Reduced flow for Extended period. Dustech can be provided fire protection damper.

COWL :- Dustech provides cowl at fan outlet for the protection from rain or dust to enter from the outlet.

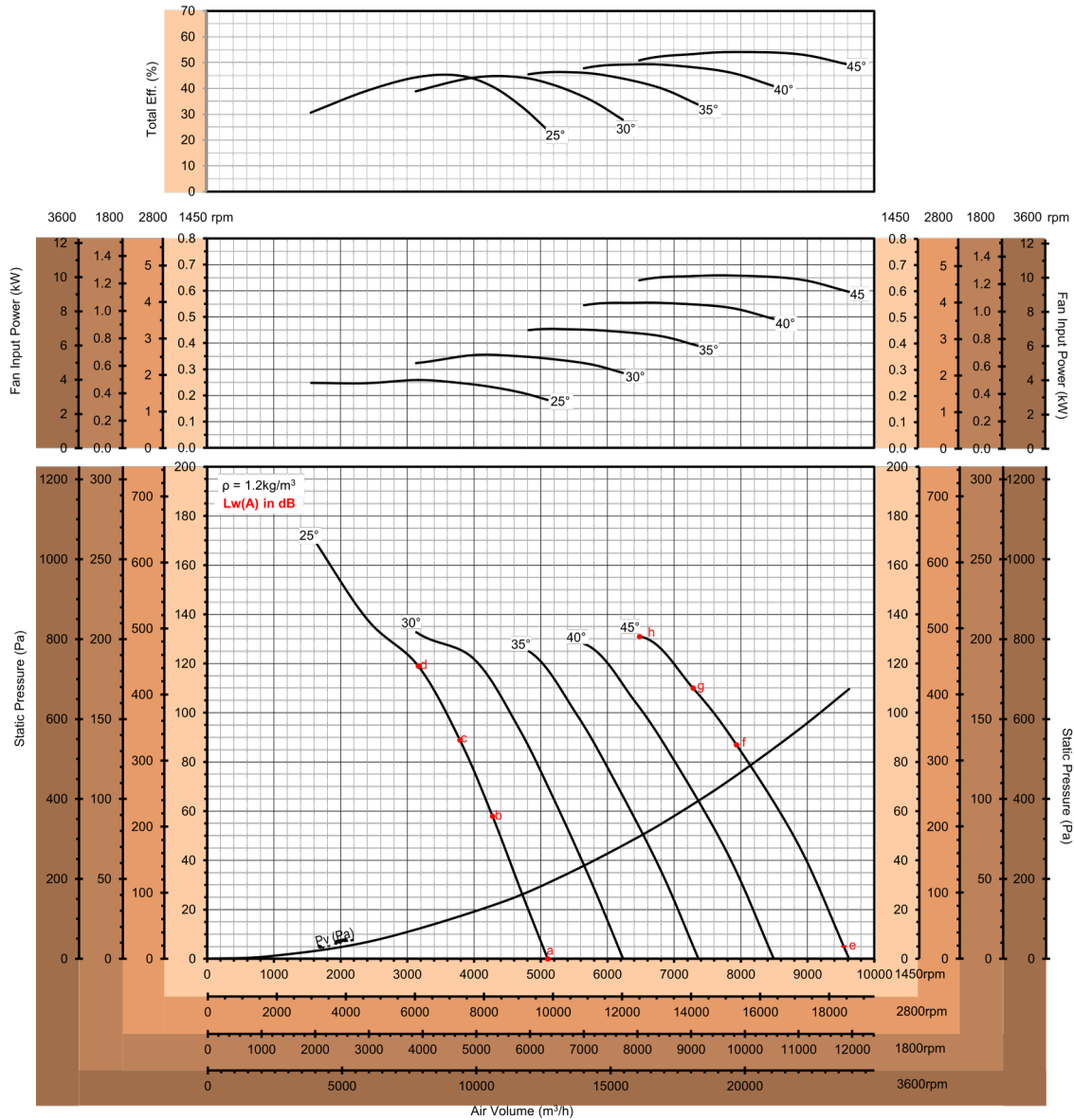

LwA (dB)	Fan Speed (rpm)			
	1450	2800	1800	3600
a	77	93	82	99
b	82	98	87	103
c	84	100	89	105
d	84	101	89	107

LwA (dB)	Fan Speed (rpm)			
	1450	2800	1800	3600
e	82	98	87	104
f	82	98	87	104
g	82	99	87	105
h	85	103	91	109

* Performance certified is for installation type D - Ducted inlet, Ducted outlet. Performance ratings do not include the effects of appurtenances (accessories).

* The A-weighted sound ratings shown have been calculated per AMCA International Standard 301. Values shown are for inlet LwA sound power levels for installation type D: ducted inlet, ducted outlet. Ratings include the effects of duct end correction.

DOFA 500-133-8

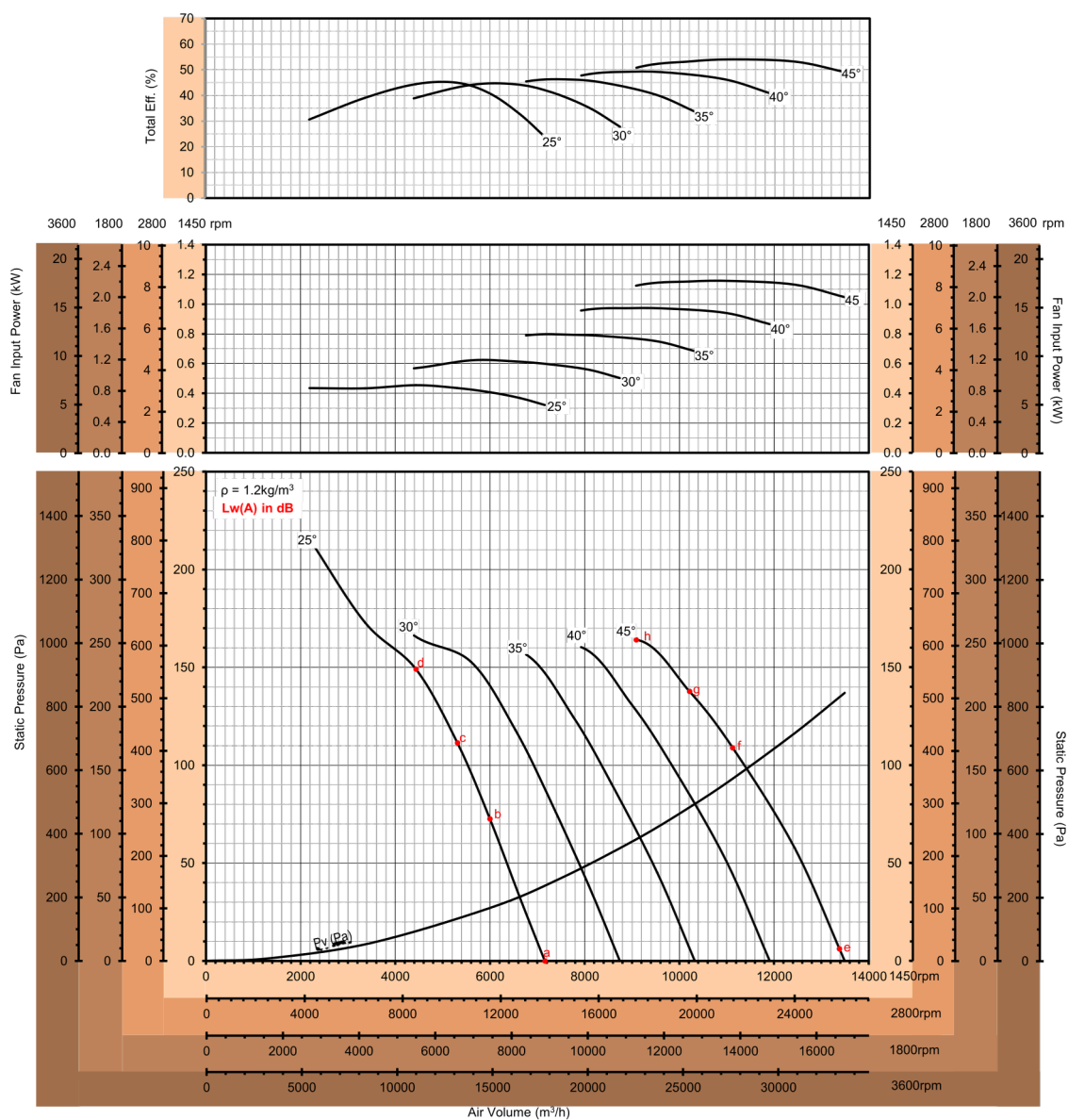

LwA (dB)	Fan Speed (rpm)			
	1450	2800	1800	3600
a	80	97	86	103
b	86	101	91	107
c	87	103	92	109
d	87	104	92	110

LwA (dB)	Fan Speed (rpm)			
	1450	2800	1800	3600
e	85	102	91	108
f	85	102	90	108
g	86	102	91	108
h	89	106	95	113

* Performance certified is for installation type D - Ducted inlet, Ducted outlet. Performance ratings do not include the effects of appurtenances (accessories).

* The A-weighted sound ratings shown have been calculated per AMCA International Standard 301. Values shown are for inlet LwA sound power levels for installation type D: ducted inlet, ducted outlet. Ratings include the effects of duct end correction.

DOFA 560-149-8

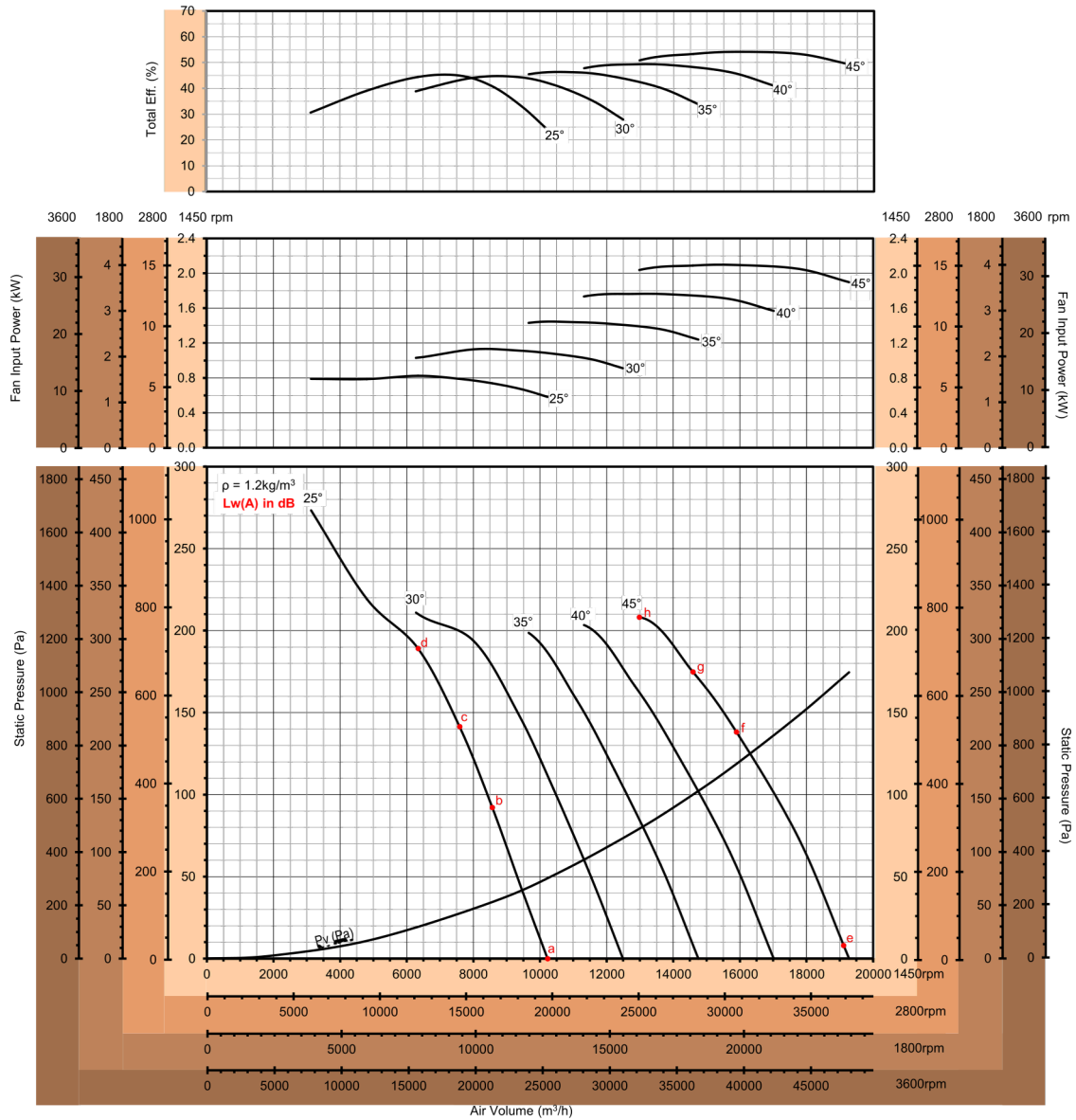

LwA (dB)	Fan Speed (rpm)			
	1450	2800	1800	3600
a	84	100	89	106
b	89	105	94	110
c	91	107	96	112
d	91	108	96	114

LwA (dB)	Fan Speed (rpm)			
	1450	2800	1800	3600
e	89	105	94	111
f	89	105	94	111
g	89	106	95	112
h	92	110	98	116

* Performance certified is for installation type D - Ducted inlet, Ducted outlet. Performance ratings do not include the effects of appurtenances (accessories).

* The A-weighted sound ratings shown have been calculated per AMCA International Standard 301. Values shown are for inlet LwA sound power levels for installation type D: ducted inlet, ducted outlet. Ratings include the effects of duct end correction.

DOFA 630-167.5-8

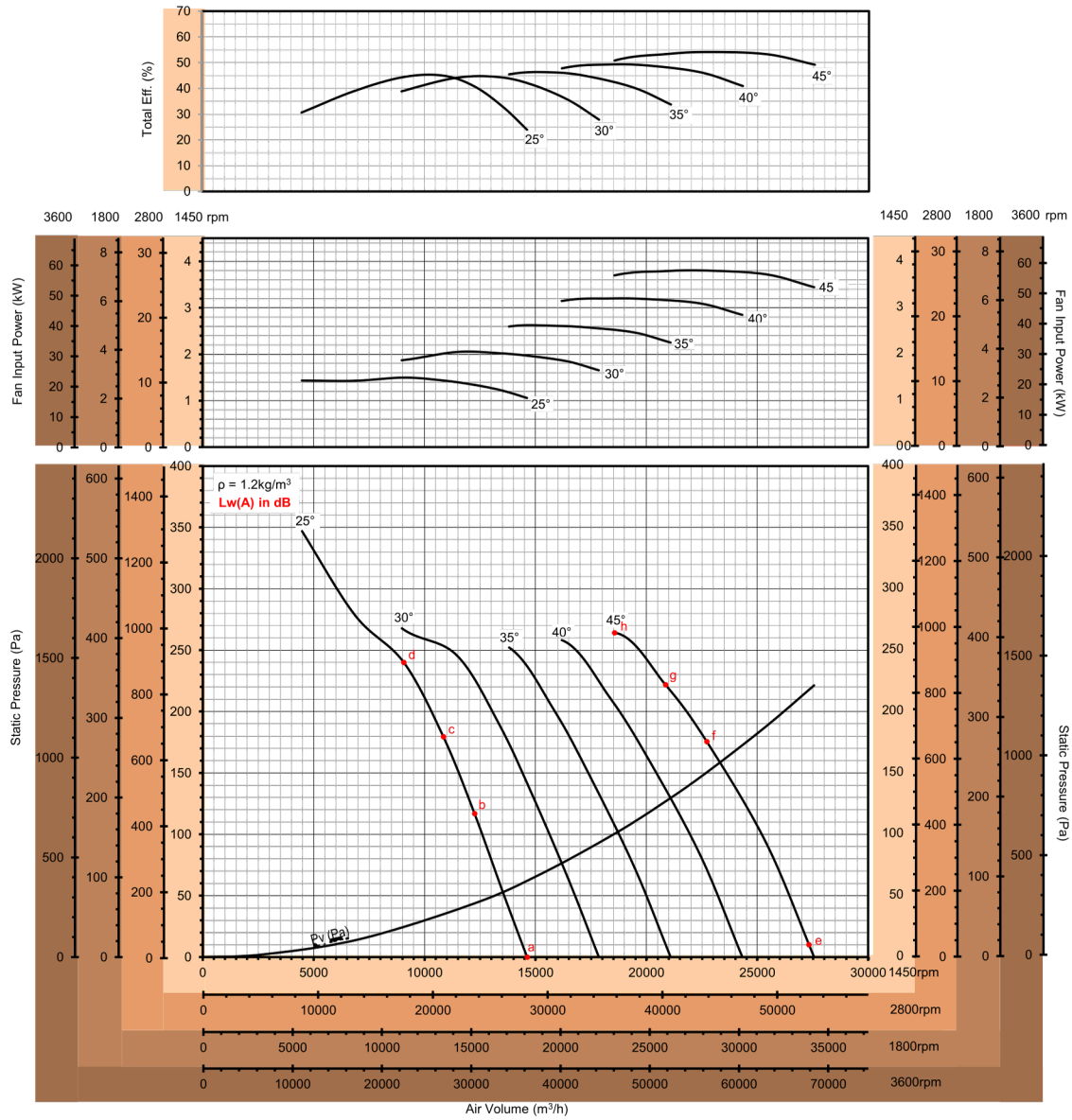

LwA (dB)	Fan Speed (rpm)			
	1450	2800	1800	3600
a	88	104	93	110
b	93	108	98	114
c	94	110	99	116
d	94	111	100	117

LwA (dB)	Fan Speed (rpm)			
	1450	2800	1800	3600
e	92	109	98	115
f	92	109	98	115
g	93	109	98	116
h	96	113	102	120

* Performance certified is for installation type D - Ducted inlet, Ducted outlet. Performance ratings do not include the effects of appurtenances (accessories).

* The A-weighted sound ratings shown have been calculated per AMCA International Standard 301. Values shown are for inlet LwA sound power levels for installation type D: ducted inlet, ducted outlet. Ratings include the effects of duct end correction.

DOFA 710-189-8

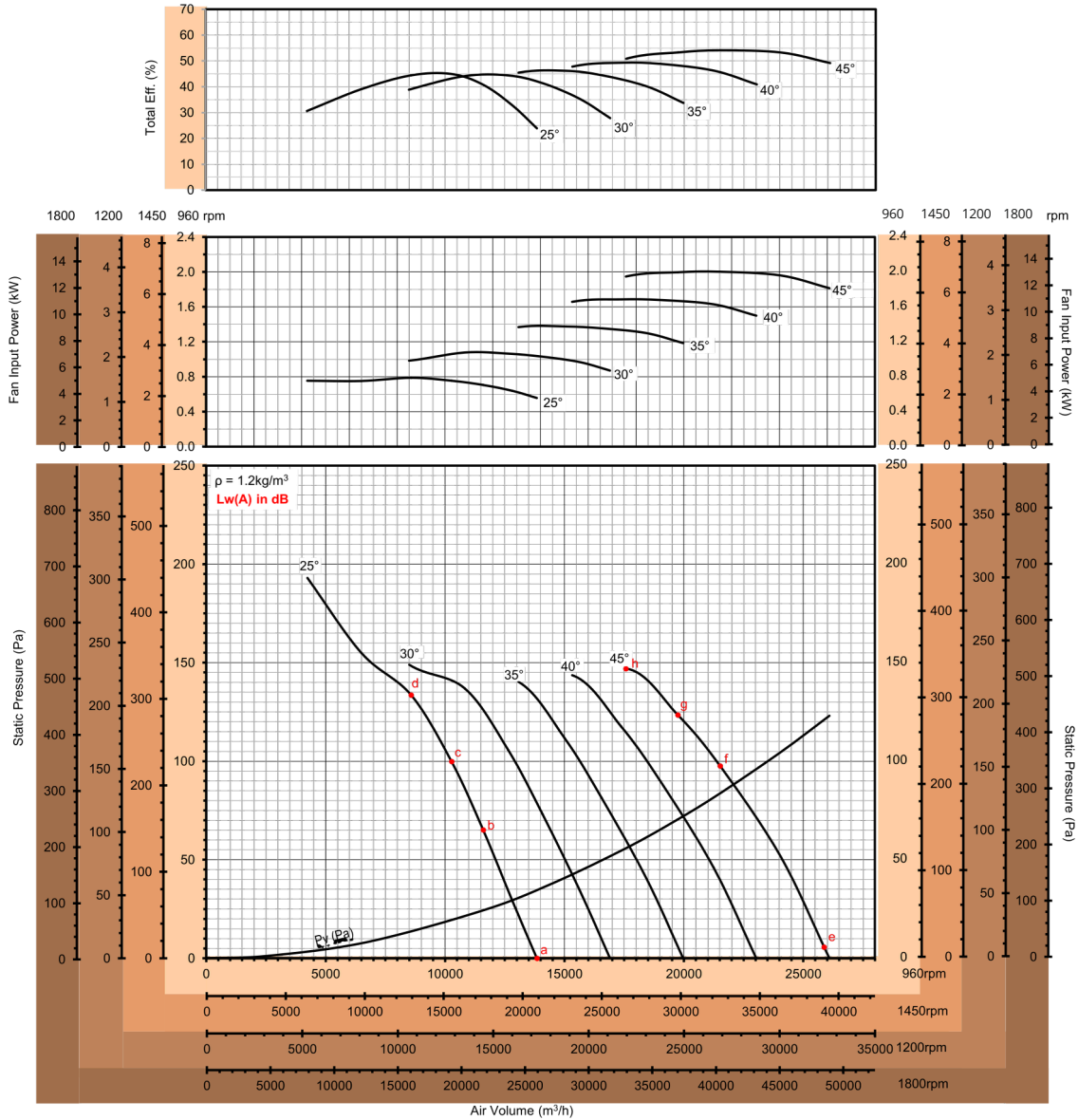

LwA (dB)	Fan Speed (rpm)			
	960	1450	1200	1800
a	81	91	87	97
b	86	97	92	101
c	87	98	93	103
d	87	98	93	103

LwA (dB)	Fan Speed (rpm)			
	960	1450	1200	1800
e	86	96	91	101
f	85	96	91	101
g	86	96	92	102
h	89	100	95	105

* Performance certified is for installation type D - Ducted inlet, Ducted outlet. Performance ratings do not include the effects of appurtenances (accessories).

* The A-weighted sound ratings shown have been calculated per AMCA International Standard 301. Values shown are for inlet LwA sound power levels for installation type D: ducted inlet, ducted outlet. Ratings include the effects of duct end correction.

DOFA 800-213-8

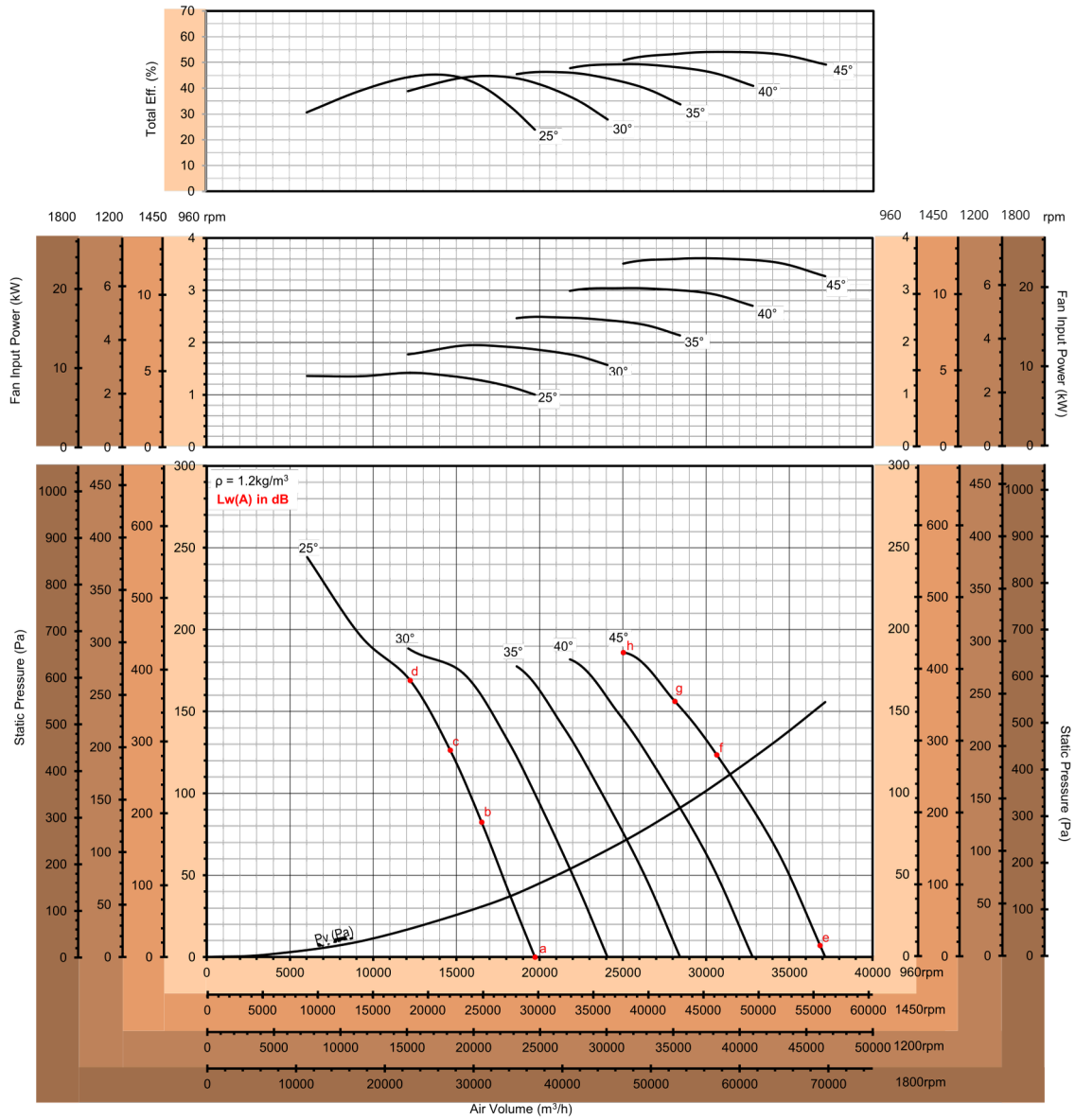

LwA (dB)	Fan Speed (rpm)			
	960	1450	1200	1800
a	85	95	90	100
b	90	100	95	105
c	91	101	96	107
d	90	102	96	107

LwA (dB)	Fan Speed (rpm)			
	960	1450	1200	1800
e	89	100	95	105
f	89	99	95	105
g	89	100	95	105
h	92	103	98	109

* Performance certified is for installation type D - Ducted inlet, Ducted outlet. Performance ratings do not include the effects of appurtenances (accessories).

* The A-weighted sound ratings shown have been calculated per AMCA International Standard 301. Values shown are for inlet LwA sound power levels for installation type D: ducted inlet, ducted outlet. Ratings include the effects of duct end correction.

DOFA 900-239.5-8

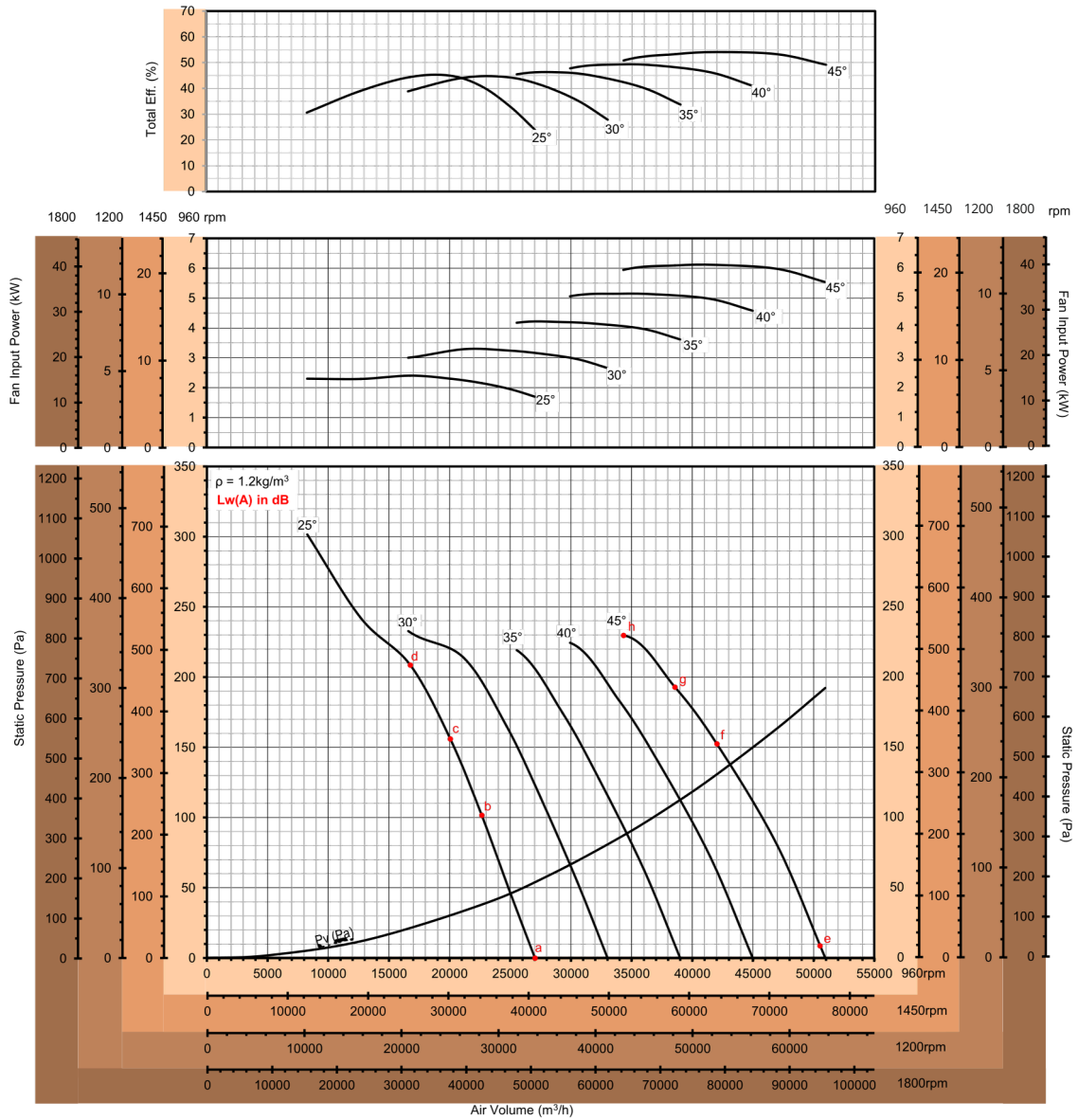

LwA (dB)	Fan Speed (rpm)			
	960	1450	1200	1800
a	88	98	93	103
b	93	103	99	108
c	94	105	100	110
d	93	105	100	110

LwA (dB)	Fan Speed (rpm)			
	960	1450	1200	1800
e	92	103	98	108
f	92	103	98	108
g	93	103	98	109
h	95	106	101	112

* Performance certified is for installation type D - Ducted inlet, Ducted outlet. Performance ratings do not include the effects of appurtenances (accessories).

* The A-weighted sound ratings shown have been calculated per AMCA International Standard 301. Values shown are for inlet LwA sound power levels for installation type D: ducted inlet, ducted outlet. Ratings include the effects of duct end correction.

DOFA 1000-266-8

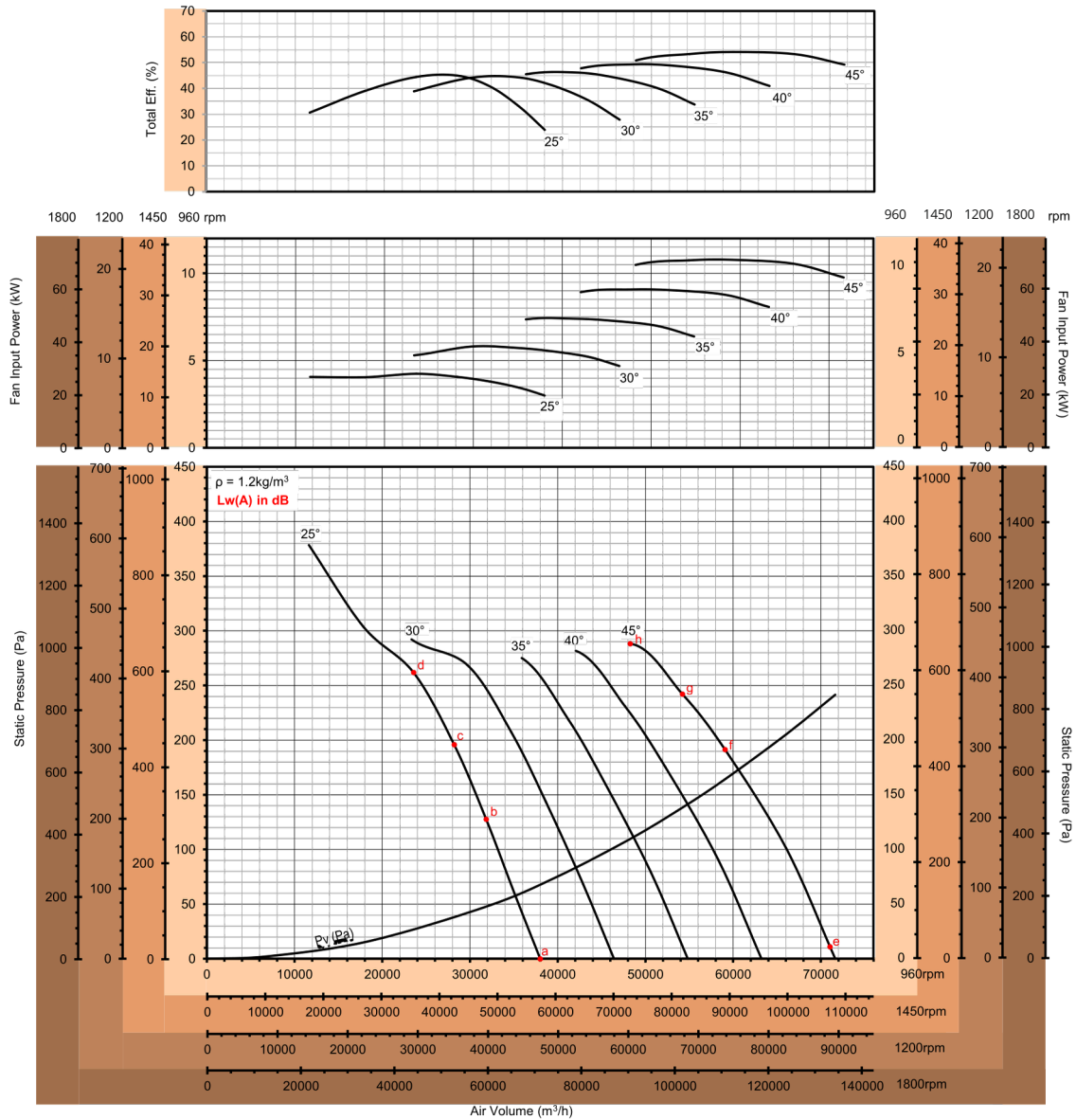

LwA (dB)	Fan Speed (rpm)			
	960	1450	1200	1800
a	91	102	97	107
b	97	107	102	112
c	97	108	103	113
d	97	108	103	114

LwA (dB)	Fan Speed (rpm)			
	960	1450	1200	1800
e	96	106	101	112
f	96	106	101	111
g	96	107	102	112
h	99	110	105	116

* Performance certified is for installation type D - Ducted inlet, Ducted outlet. Performance ratings do not include the effects of appurtenances (accessories).

* The A-weighted sound ratings shown have been calculated per AMCA International Standard 301. Values shown are for inlet LwA sound power levels for installation type D: ducted inlet, ducted outlet. Ratings include the effects of duct end correction.

DOFA 1120-298-8

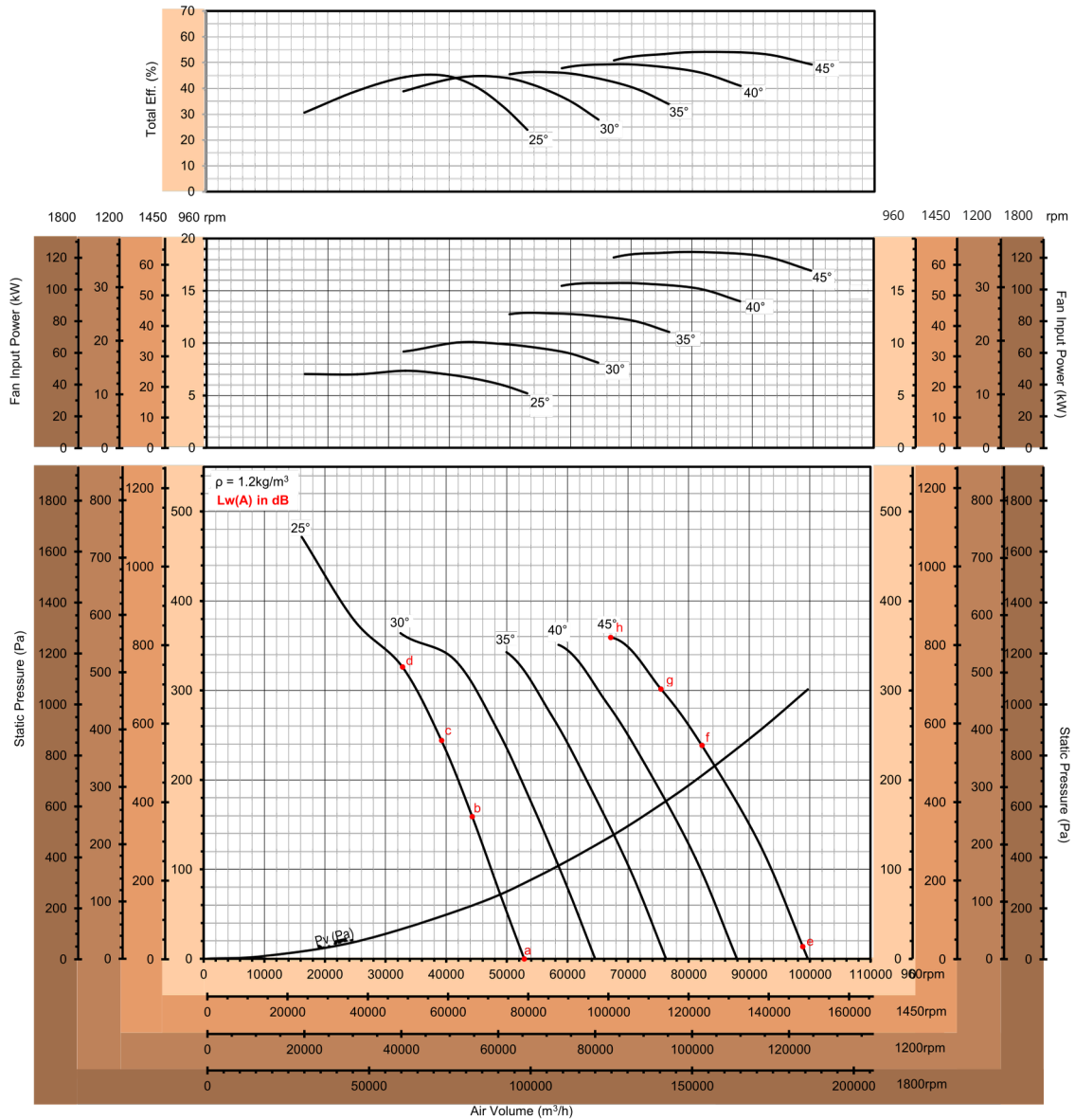

	LwA (dB)	Fan Speed (rpm)			
		960	1450	1200	1800
a	95	105	100	110	
b	100	110	105	115	
c	101	111	106	117	
d	100	112	106	117	

	LwA (dB)	Fan Speed (rpm)			
		960	1450	1200	1800
e	99	110	105	115	
f	99	109	105	115	
g	99	110	105	115	
h	102	113	108	119	

* Performance certified is for installation type D - Ducted inlet, Ducted outlet. Performance ratings do not include the effects of appurtenances (accessories).

* The A-weighted sound ratings shown have been calculated per AMCA International Standard 301. Values shown are for inlet LwA sound power levels for installation type D: ducted inlet, ducted outlet. Ratings include the effects of duct end correction.

DOFA 1250-332.5-8

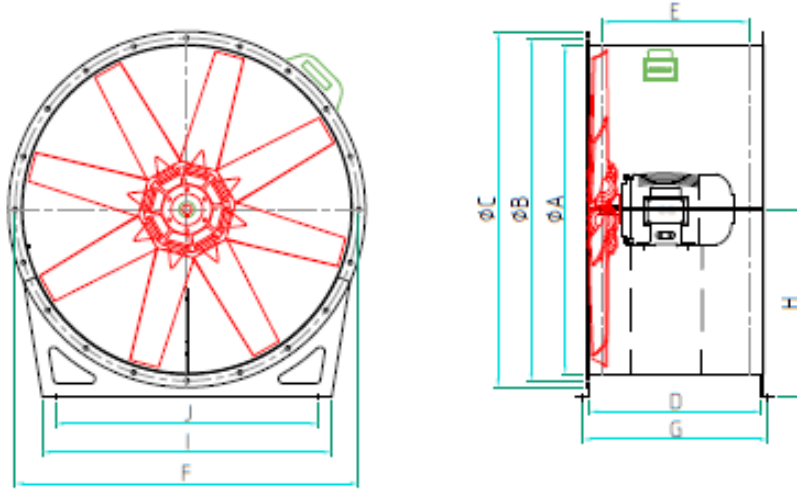

Model	ØA ID	ØB PCD	ØC	D	N @ Slot	E	F	M x Ø	G	H	I	J	P x Ø
DOFA-500	505	545	585	325	8 @ 10x14	265	545	4 x Ø12	365	320	450	370	4 x Ø12
DOFA-560	565	605	645	325	8 @ 10x14	265	605	4 x Ø12	365	350	500	420	4 x Ø12
DOFA-630	635	675	715	430	12 @ 10x14	370	675	4 x Ø12	470	385	560	480	4 x Ø12
DOFA-710	715	755	795	430	16 @ 12x16	370	755	4 x Ø12	470	425	630	550	4 x Ø12
DOFA-800	805	845	885	430	16 @ 12x16	370	845	4 x Ø14	470	470	710	630	4 x Ø14
DOFA-900	905	945	985	535	16 @ 12x16	475	945	4 x Ø14	575	520	800	720	4 x Ø14
DOFA-1000	1005	1045	1085	535	16 @ 12x16	475	1045	4 x Ø14	575	570	880	800	4 x Ø14
DOFA-1120	1125	1165	1205	640	20 @ 12x16	580	1165	4 x Ø14	680	630	970	890	4 x Ø14
DOFA-1250	1255	1295	1335	640	20 @ 12x16	580	1295	4 x Ø14	680	695	1100	1020	4 x Ø14

DOFA Series Axial Flow FAN



FAN LAWS

$$CMH_2 = CMH_1 \times \left(\frac{RPM_2}{RPM_1}\right)^1 \times \left(\frac{D_2}{D_1}\right)^3 \times \left(\frac{d_2}{d_1}\right)^0$$

$$SP_2 = SP_1 \times \left(\frac{RPM_2}{RPM_1}\right)^2 \times \left(\frac{D_2}{D_1}\right)^2 \times \left(\frac{d_2}{d_1}\right)^1$$

$$BKW_2 = BKW_1 \times \left(\frac{RPM_2}{RPM_1}\right)^3 \times \left(\frac{D_2}{D_1}\right)^5 \times \left(\frac{d_2}{d_1}\right)^1$$

CMH -Air quantity in Cubic Meter per Hour

SP-Static Pressure in mm WG

BKW- Fan Brake Kilowatt

RPM- Fan revolution per minute

D- Fan diameter

d- Density of air Standard air density = 1.2kg/m³

At higher than standard elevations and temperatures, air density will be lower than standard.

1- Initial State

2- Final State

To calculate:

Total Pressure = static pressure + velocity Pressure

Velocity Pressure (Pa) = $\frac{1}{2} \times d$ (density of air kg/m³) \times (Fan Outlet velocity m/s)²

Fan outlet Velocity (m/s) = CMH \div Duct area (sq. mtr) \div 3600

Tip speed (m/s) = π fan diameter (mtr) \times fan rpm \div 60

Total efficiency n% = $\frac{CMS \times Total Pressure (mm WG)}{102 \times BKW}$

102 x BKW

DOFA Series Axial Flow FAN



CONVERSION TABLE

	I-P EQUIVALENTS OF METRIC UNITS	METRIC EQUIVALENTS OF I-P UNITS
Area	1 M2 (Square meter) = 10.764 ft2	1 ft2)Square foot) = .09290 m2
Density	1 kg/m3 = .062428 ibm/ft3 1 g/cm3 = 62.428 ibm/ft3	1 lbm/ft3 = 16.018 kg/m3 1 lbm/ft3 = .016018 g/cm3
Energy	1 J (Joule) or N-m (Newton-meter) = .73756 ft-lb 1 Kcal (kilo calorie) = 3.9683 btu	1 ft-lb (foot pound) = 1.3558 N-m 1 Btu (British thermal unit)= 252 Cal
Flow rate (Volume)	1 m3/s (cubic meter per second) CMS= 2118.9 CFM 1 M3/Min(cubic meter per minute) CMM =35.315 CFM 1 m3 /Hr (Cubic meter per hour) CMH =.58858 CFM 1 l/s (litter per second) = 2.1189 CFM	1 CFM (Cu.ft/min) = .00047195 m3/s 1 CFM =.02832 M3/min 1 CFM =1.6990 M3 /hr 1 CFM = .47195 l/s
Force	1 N (Newton) = .22481 lb 1 Kp (Kilopond) = 2.2046 lb	1 lb (pound) = 4.4482 N 1 lb = .45359 kp



<p>Gas constant</p>	<p>1 J/kg-K (Joule per kilogram kelvin)= .18586 ft-lb/lbm-R 1 M2/S2-K(Sqmt per sec.sq.kelvin) = 5.9800 ft2/s2-R 1 Cal/g-C (Calorie per gram C) =4186.8 J/Kg-K</p>	<p>1 ft-lb/lbm-R* = 5.3803 J/Kg-K 1 ft2/s2-R** = .16723 m2/s2-K 1 Btu/lbm -R =1.0000 CAL/G-C * (Foot-pound per pound mass degree rankine) *(square-foot per second-square degree rankine)</p>
<p>Length</p>	<p>1 mm (Millimetre =.03937 1 cm (centimetre) =.39370 inch 1 m (meter) =3.2808 ft 1 km (kilometre) = .62137 mi</p>	<p>1" (inch) = 25.4 mm 1" =2.54 cm 1 ft (foot) =.30480 m 1 mi (mile) =1.6093 km</p>
<p>Mass</p>	<p>1 kg (kilogram) = 2.2046 lbm</p>	<p>1 lbm (pound mass) =.45359 kg</p>
<p>Power</p>	<p>1 w (watt)=.00134 HP 1 KW (kilo-watt)= 1.3410 HP 1 mhp (metric horsepower)= .98632 hp</p>	<p>1 hp (horsepower) = .7457 kw 1 hp =745.70 w 1 hp = 1.0139 mhp</p>
<p>Pressure of stress</p>	<p>1 N/m2 (newton per m2) or pa (Pascal) = .0040264" wg 1 mm hg or torr (mm mercury) =.53616" wg 1Kpa (kilo Pascal) = .1450 psi 1 atm (atmosphere)=29.921" hg (mm hg at 0°c or 68°f) 1 oz√in = 1.732" wg</p>	<p>1" wg (inches water gauge) =248.66 pa or N/m2 1 wg =1.8651 mm hg or torr 1 psi (ponds per sq. Inch) = 6894.8 pa N/m2 1" hg (inch mercury)=3386.4 pa or N/m2 (Inches wg at 68 F Or 20 C) 1"wg =0.5774 oz √in2</p>

DOFA Series Axial Flow FAN



<p>Pressure of stress</p>	<p>1 N/m² (newton per m²) or pa (Pascal) = .0040264" wg 1 mm hg or torr (mm mercury) =.53616" wg 1Kpa (kilo Pascal) = .1450 psi 1 atm (atmosphere)=29.921" hg (mm hg at 0°c or 68°f) 1 oz/in = 1.732" wg</p>	<p>1" wg (inches water gauge) =248.66 pa or N/m² 1 wg =1.8651 mm hg or torr 1 psi (ponds per sq. Inch) = 6894.8 pa N/m² 1" hg (inch mercury)=3386.4 pa or N/m² (Inches wg at 68 F Or 20 C) 1"wg =0.5774 oz √in²</p>
<p>Power</p>	<p>1 w (watt)=.00134 HP 1 KW (kilo-watt)= 1.3410 HP 1 mhp (metric horsepower)= .98632 hp</p>	<p>1 hp (horsepower) = .7457 kw 1 hp =745.70 w 1 hp = 1.0139 mhp</p>
<p>Pressure of stress</p>	<p>1 N/m² (newton per m²) or pa (Pascal) = .0040264" wg 1 mm hg or torr (mm mercury) =.53616" wg 1Kpa (kilo Pascal) = .1450 psi 1 atm (atmosphere)=29.921" hg (mm hg at 0°c or 68°f) 1 oz/in = 1.732" wg</p>	<p>1" wg (inches water gauge) =248.66 pa or N/m² 1 wg =1.8651 mm hg or torr 1 psi (ponds per sq. Inch) = 6894.8 pa N/m² 1" hg (inch mercury)=3386.4 pa or N/m² (Inches wg at 68 F Or 20 C) 1"wg =0.5774 oz √in²</p>

DOFA Series Axial Flow FAN



<p>Temperature</p>	<p>For temperature intervals and rise, for temperature intervals and rise 1 C (Degree Celsius) = 9/5 F For temperature in F (Fahrenheit) = tc x9/5+32</p>	<p>1 F (degree Fahrenheit) =5/9 c For temperature in c =(tF-32)X5/9</p>
<p>Torque</p>	<p>1 N-m newton meter) = 8.8507 lb-in 1 N-m (Newton Meter) = .73756 lb-ft</p>	<p>1 LB-IN (PPOUND INCH) =.11298 N-m 1 lb-ft (pound foot) = 1.3558N-m</p>
<p>Velocity & speed</p>	<p>1m/s = 196.5 fpm 1 km/hr (kilometre per hour) = .62137 mph 1 rps (revolution per second) =.016667 rpm</p>	<p>1 fpm (feet per minute) = .00508 m/s 1 mph (mile per hour) = 1.6093 km/hr 1 rpm (revolution per minute) = 60rps</p>
<p>Viscosity</p>	<p>1 Cp (centipoise) =.00067197 lbm/ft-s</p>	<p>lbm/ft-s (pound/foot second) =1488.2 cP1</p>

DOFA Series Axial Flow FAN



INSTALLATION AND MAINTENANCE

INSTALLATION: “DUSTECH” fans may be mounted in any position. For convenience in wiring and service, the motor should be readily accessible. On direct drive units, access through Adjacent duct work is recommended. On belt drive units, the motor position must be considered with regard to service and adjacent objects such as wall or ceiling. The duct fan has flanged ends on the steel housing for convenient mounting directly to the duct system. Flexible connections or transition pieces may be utilized to reduce noise transmission, simplify duct attachment, and provide access to the fan interior. If the fan cannot be adequately supported by duct work or otherwise, optional mounting feet should be utilized. Type of support (floor or ceiling) and location relative to motor or access panel will determine proper type and location of mounts needed. Always check blade clearance and direction of rotation before operating.

Figure 1.1. - Inlet Cones Use inlet cones for axial fan free air intakes to improve performance and noise level.

✗ Don't

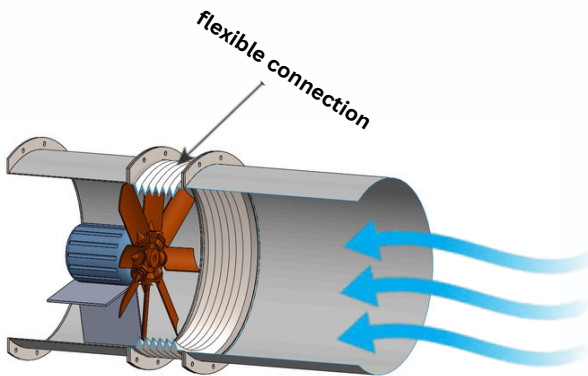

An abrupt entry will generate turbulence at the impeller. Note Blade tips will be starved of air which reduces pressure Development capability, induces stall and increase the noise Level generated by the fan.

✓ DO

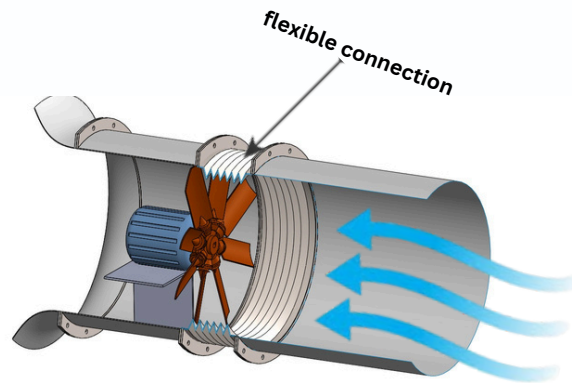

By fitting a correctly designed inlet cone the air flow to the impeller will be uniform resulting in the performance being optimised and minimum noise level generated.

Figure 1.2. - Turning vanes at sharp bends Fit turning vanes in elbows adjacent to axial fans

✗ Don't

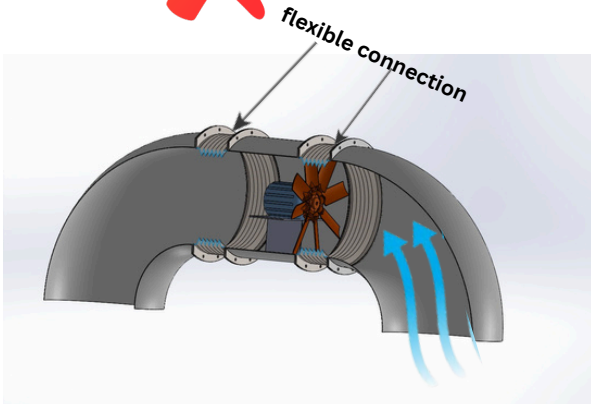

Eccentric flow conditions at both inlet and outlet will result in part of the impeller being starved of air and the fan not operating satisfactorily.

✓ DO

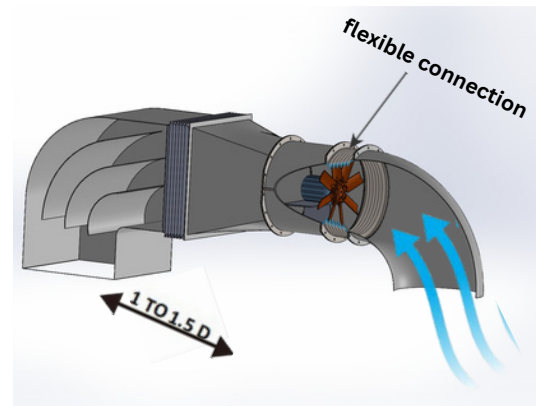

Square-to-round transitions and turning vanes in elbows assists uniform airflow; this is a compromise only and by no means ideal.

Figure 1.3. - Flexible connection to fan Flexible connections must be taut or else turbulence at the fan inlet, noise level and pressure loss are all increased

✗ Don't

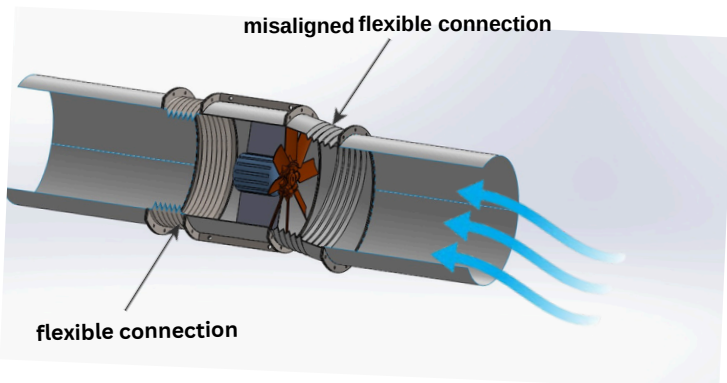

Slack or misaligned flexible connectors reduce the effective duct area. This generates turbulence and the blade tips are starved of air. Fan performance is reduced and noise levels increased

✓ DO

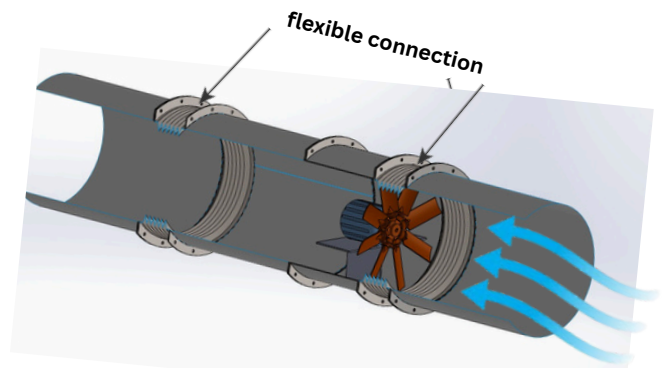

If flexible connectors are fitted they should be remote from the fan and ensure they are taut. The air to the impeller tips is then not obstructed allowing the fan to operate to its optimum and minimises noise generation.

Figure 1.4. - Duct restrictions at fans Ducts significantly smaller than the fan diameter create turbulence if transitions connect directly to fan

✗ Don't

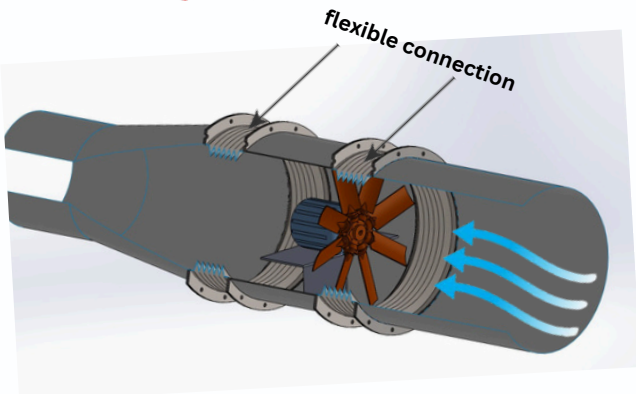

An abrupt duct expansion at fan inlet causes air separation from the duct, starves the impeller tips, creates turbulence, reduces performance and generates increased noise

✓ DO

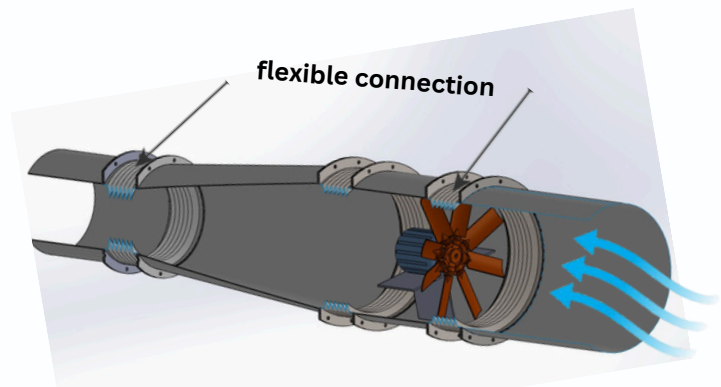

Duct expansions on the inlet to axial flow fans should be avoided where at all possible. If essential the transition should have an included angle of not more than 15°

Figure 1.5. - Pressure recovery Look for opportunities for static pressure recovery at axial exhaust fan outlets.

✗ Don't

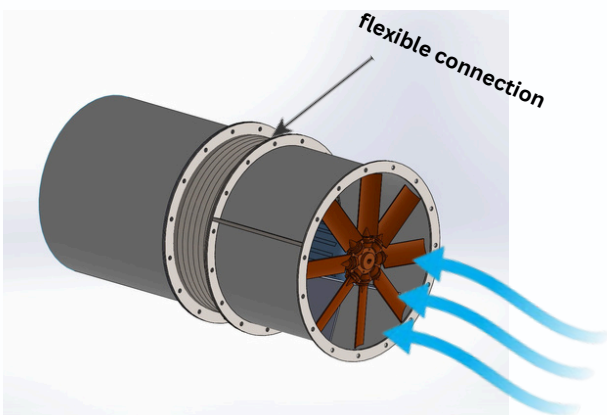

To determine the system resistance the discharge losses have to be added before selecting the fan. Discharge losses are highest in this arrangement and are equivalent to one velocity head.

✓ DO

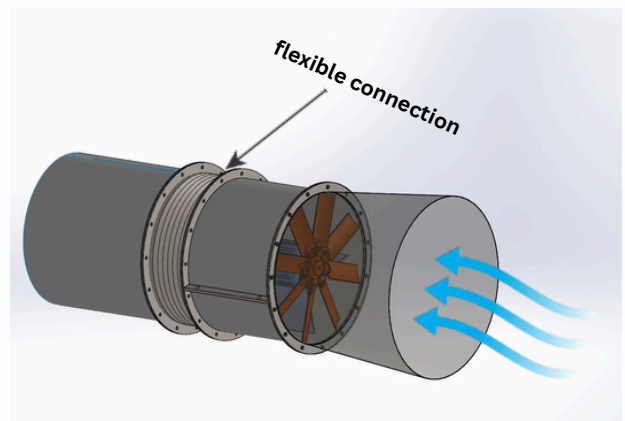

With a correctly designed discharge diffuser the pressure recovery in the diffuser will reduce the system total pressure. Included angle of diffuser to be 15° or less. Discharge losses reduced substantially in this arrangement

DOFA Series Axial Flow FAN

Figure 1.6. - Obstruction at fan outlet Don't obstruct fan outlet.

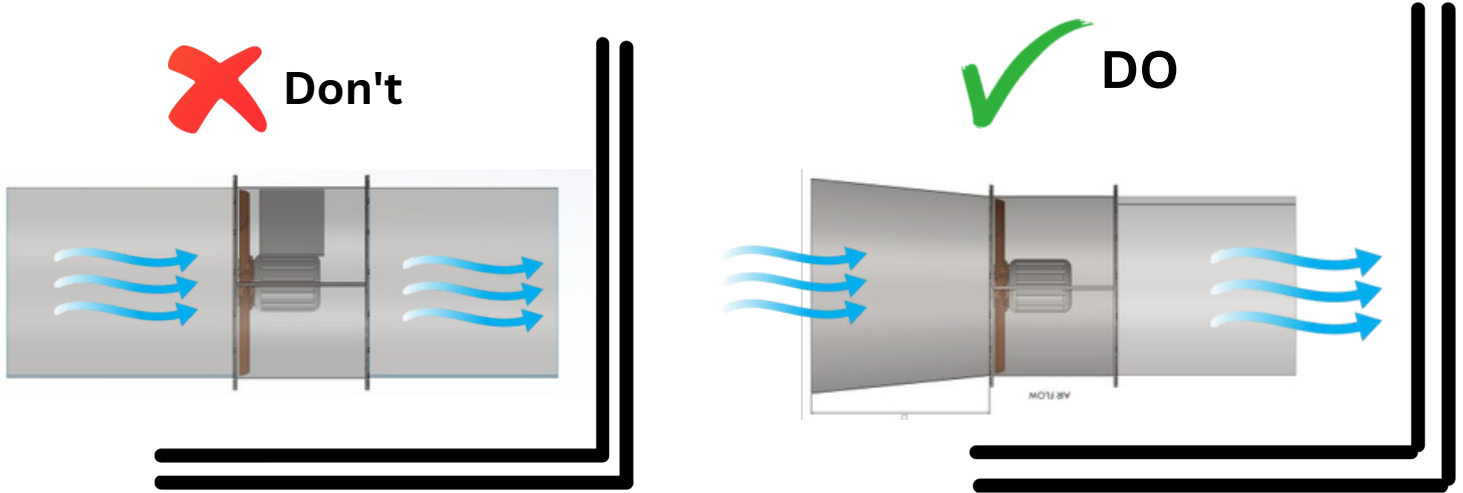

Allow a gap of at least one fan diameter between fan outlet and obstruction and fit a diffuser on the discharge

Figure 1.7. - Obstructions at fan inlets Don't obstruct fan inlets.

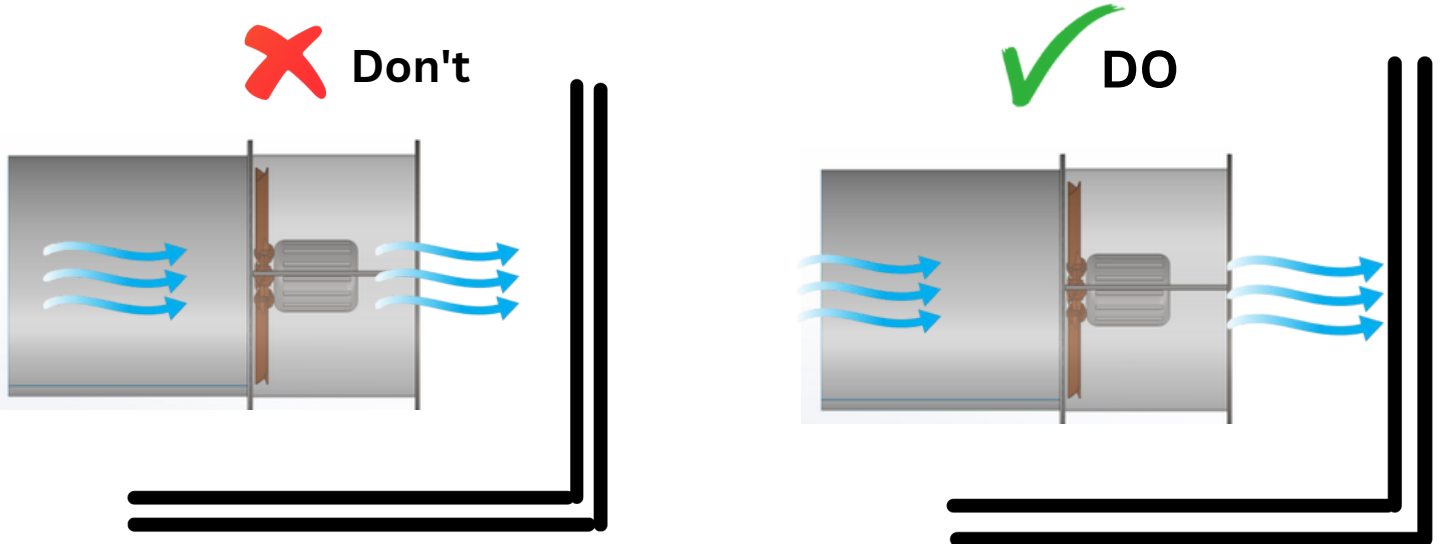

The impeller can be starved of air when the inlet to the fan is obstructed. This effectively increases the system resistance thereby reducing the air flow being handled by the fan. This applies to all fan types.

Allow a gap at least equal to one fan diameter between the fan intake and nearby obstructions, even then fan performance can be less than rated. Always fit an inlet cone on open axial fan inlets

DOFA Series Axial Flow FAN



Figure 1.8. - Guards Safety of personnel around rotating machinery is crucial

✗ Don't

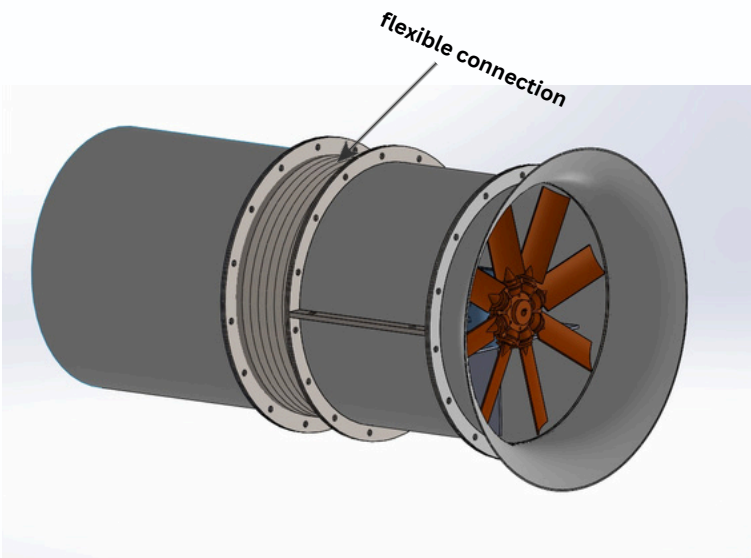

Don't leave open fan inlets unguarded. This is unsafe to personnel and machinery. In addition it may be illegal and leave the building owner or installer open to prosecution.

✓ DO

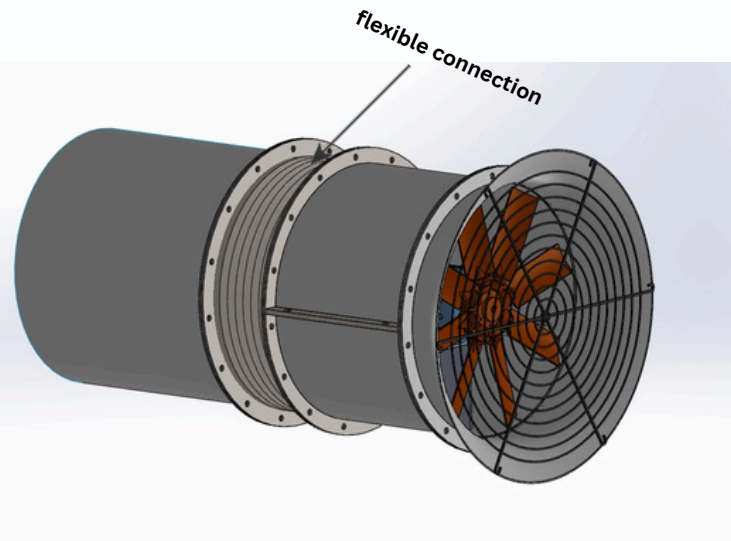

Ensure open fan inlets are fitted with suitable guards. These should be designed to comply with local regulations and not only protect against injury but lessen the risk of a foreign object entering the fan and causing damage.

FACTORS AFFECTING AIR PERFORMANCE

System Effect: A pressure loss which recognizes the effect of fan inlet restrictions, fan outlet restrictions or other conditions influencing fan performance when installed in the system. Duct elbows, transitions or other disruptions to uniform airflow may contribute to system effect, by the proximity to walls, beams and other obstruction to air flow in case of unducted fans. For a quantitative discussion of system effects refer to AMCA Publication 201 - Fans and Systems. **MAINTENANCE:** DUSTECH fans should be cleaned as necessary to remove accumulated dust, dirt and other foreign matter which may collect on the blades or interior surfaces. If belt drive, belts) should be Inspected and tension adjusted. Proper alignment. Check belts) for External Relubrication fan bearing fittings are Standard with belt drive models. Pillow-block ball Bearings should be lubricated Annually or more Frequently, depending upon conditions and operating cycle. Refer to the maintenance instructions supplied with the fan. For lubrication of the electric motor, consult the instructions provided by the motor manufacturer.

DOFA Series Axial Flow FAN

DUSTECH



Limited Warranty : In the sale of its products, DUSTECH Corporation agrees to correct, by repairs or replacement, any defects in workmanship or material that may develop under proper and normal use during the period of one year from date of shipment from factory. Any product or part proving, upon DUSTECH examination, to be defective during limited warranty period will be repaired or replaced, at DUSTECH option, f.o.b. factory, without charge. Deterioration or wear caused by chemicals, abrasive action or excessive heat shall not constitute defects. Motors are guaranteed only to the extent of manufacturer's warranty. DUSTECH limited warranty does not apply to any of its products or parts that have been subject to accidental damage, misuse by the user, unauthorized alterations, improper installation or electrical wiring, or lack of proper lubrication or other service requirements established by DUSTECH.

Works Address: -

Village Nangla Bhiku, Distt. Palwal 121102,
Haryana, INDIA

gagan@dustech.in

+91 9811205058

OUR PRODUCTS



DOFA Series Axial Flow FAN

002-01-FEBRUARY-2025