

DOUBLE-WIDTH ACOUSTAFOIL[®] FANS

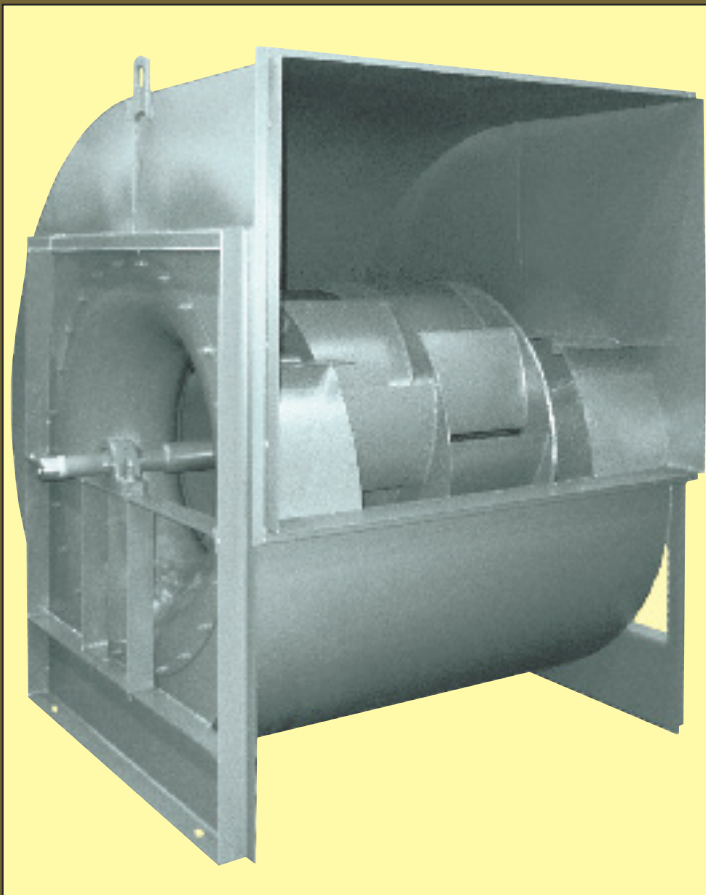

- Class 1, 2, 3 construction
- Capacities to 350,000 CFM

- Static pressures to 14"WG
- Efficiencies beyond 85%



56 12th Avenue Extension
Caloocan City, Philippines 1400
Tel. Nos. : (632) 8366-1968
Fax No : (632) 8362-4257
Email: sales@niagarafans.com
Website: www.niagarafans.com

Manufactured under license from



THE NEW YORK BLOWER COMPANY
7660 Quincy Street
Willowbrook, IL 60527-5530

Visit us on the Web: <http://www.nyb.com>
Phone: (800) 208-7918 Email: nyb@nyb.com

DOUBLE-WIDTH ACOUSTAFOIL® FANS

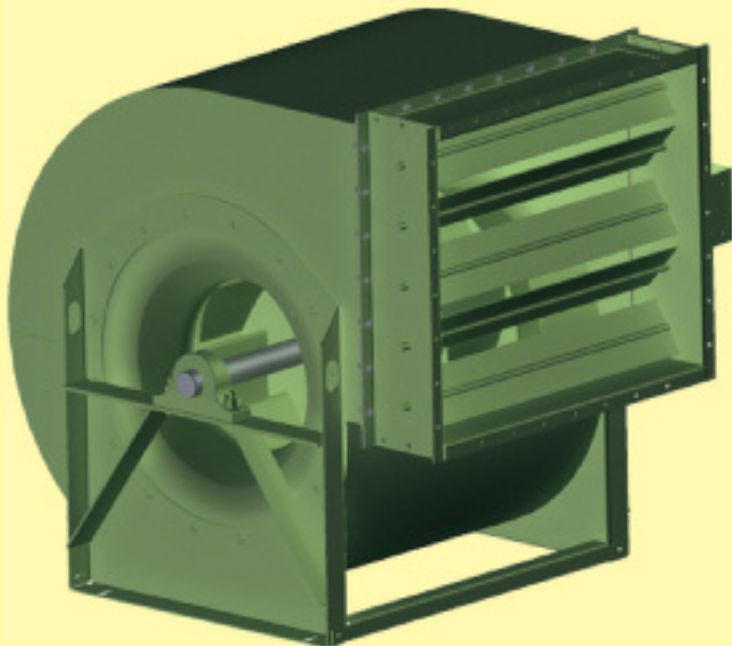

Size 24 Class 2 Fan with optional flanged outlet and opposed-blade outlet damper [representative of Sizes 18-27 Class 1 and 2 construction].



Niagara Industrial Equipment Corp certifies that the Double-Width AcoustaFoil Fans shown on pages 7 through 13 shown herein are licensed to bear the AMCA Seal. The ratings shown are based on tests and procedures performed in accordance with AMCA Publication 211 and comply with the requirements of the AMCA Certified Ratings Program.



The New York Blower Company's Double-Width AcoustaFoil Fans combine the efficiency of its airfoil wheels with construction features to suit industrial supply and exhaust systems as well as heating, ventilating, and air-conditioning applications. A wide range of accessories is available to tailor Double-Width AcoustaFoil Fans to each unique application. The state-of-the-art laboratory and design and manufacturing facilities of The New York Blower Company ensure that Double-Width AcoustaFoil Fans provide the utmost in equipment value.

DESIGN FEATURES

- Complete AMCA Class 1, 2, 3 performance.
- Capacities to 350,000 CFM.
- Pressures to 14"WG.
- Efficiencies beyond 85%.
- Temperatures to 120°F.
- Twenty sizes: 10" through 73" wheel diameters.
- Available in clockwise and counterclockwise rotations in any of seven standard discharge positions.
- Unique inlet cones with airflow diverters improve fan efficiency.

CONSTRUCTION FEATURES

- Heavy-gauge welded components provide structural strength and durability.
- Continuously welded housings provide the strongest possible construction.
- Bearings are selected to provide long service life through the entire operating range of the fan.
- Standard finish is a medium-green enamel.
- Shafting is straightened to close tolerance to minimize "run out" and ensure smooth operation.
- Lifting eyes are standard on all fans.
- All Double-Width AcoustaFoil wheels are dynamically balanced and all fans are checked at the specified running speed after final assembly.

WITH ACOUSTAFOIL® WHEELS

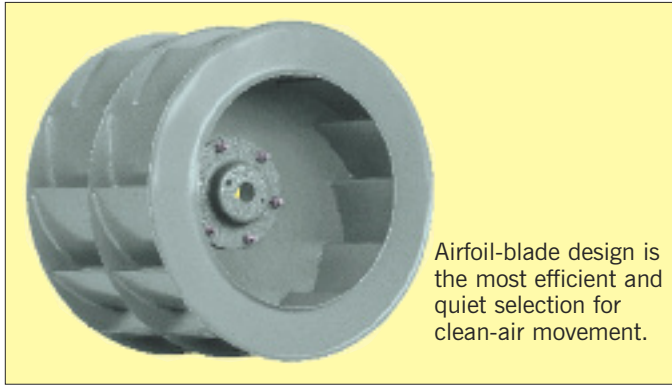

Airfoil-blade design is the most efficient and quiet selection for clean-air movement.

Stable performance—completely stable pressure curve from wide-open to closed-off...ideal for variable air volume systems.

Non-overloading horsepower curve—horsepower reaches a peak and then decreases as flow increases ...allows calculation of the maximum brake horsepower at a given fan speed so a motor can be selected that will not overload if system pressure changes.

Efficiency—the mechanical efficiency curve offers a broad selection range with little horsepower variation.

Sound—the superior efficiency of the Acoustafoil wheel provides a low sound level over a wide performance range.

TYPICAL ACOUSTAFOIL PERFORMANCE

Shaded region highlights typical performance at peak mechanical efficiency and lowest sound level.

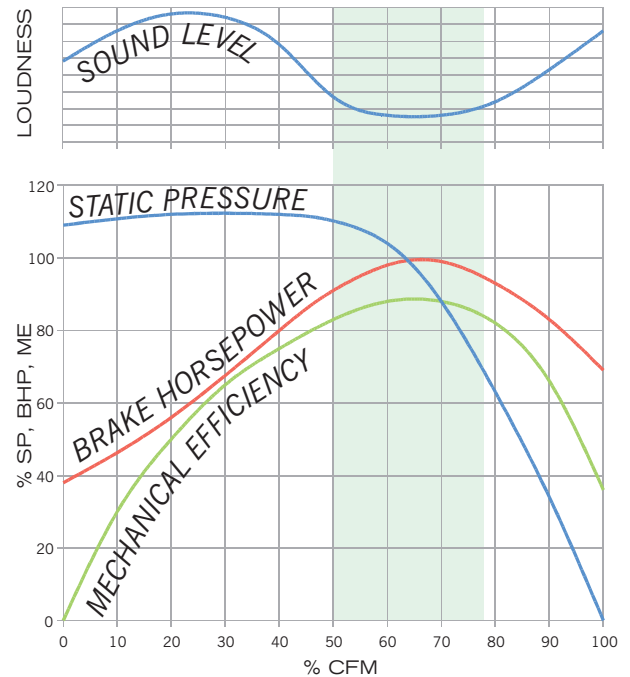

SAFETY EQUIPMENT

Safe operation of air-moving equipment is dependent on proper installation and maintenance including selection and use of appropriate safety accessories for the specific installation. Such safety accessories are available from **nyb**, but selection of the appropriate devices is the responsibility of the system designer who must be aware of adjacent components, equipment location, and accessibility in the particular installation. Neither **nyb** nor its sales representatives are in a position to make such a determination. The system designer must consider providing guards for all exposed moving parts as well as protection from access to high velocity airstreams. Improper application, installation, maintenance, or safety guard selection can create danger to life and limb of personnel. Users and/or installers should read "Recommended Safety Practices for Air Moving Devices" as published by the Air Movement and Control Association International, Arlington Heights, Illinois.

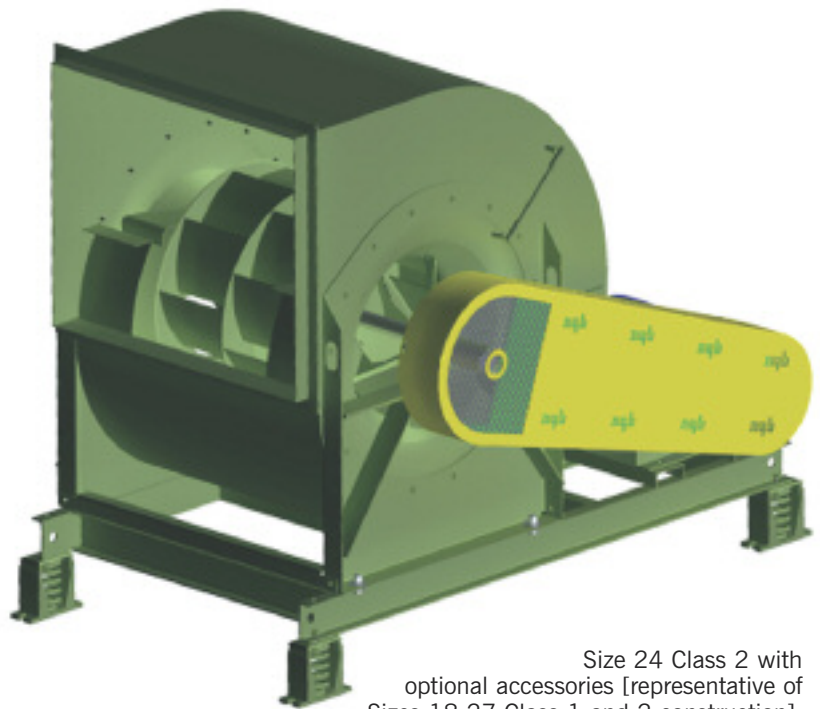

Size 24 Class 2 with optional accessories [representative of Sizes 18-27 Class 1 and 2 construction].

ACCESSORIES AND MODIFICATIONS

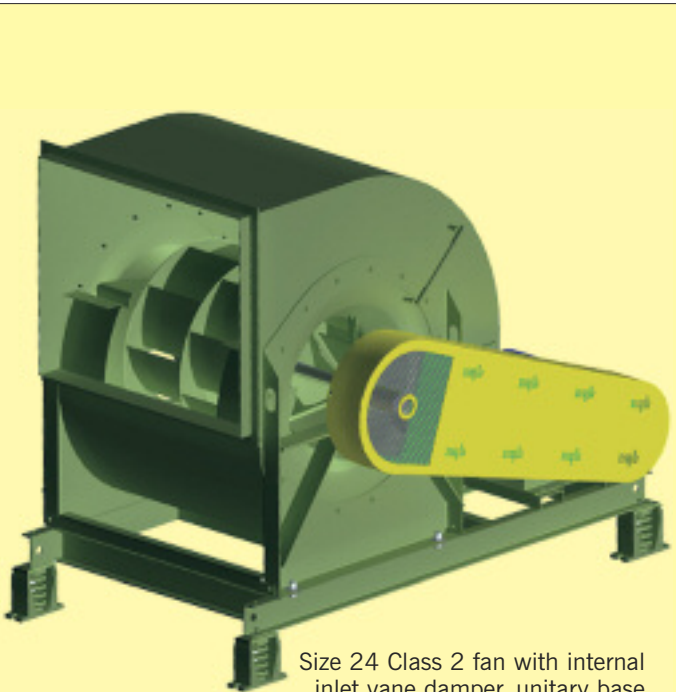

Size 24 Class 2 fan with internal inlet vane damper, unitary base with spring isolation, belt guard, motor and v-belt drive.

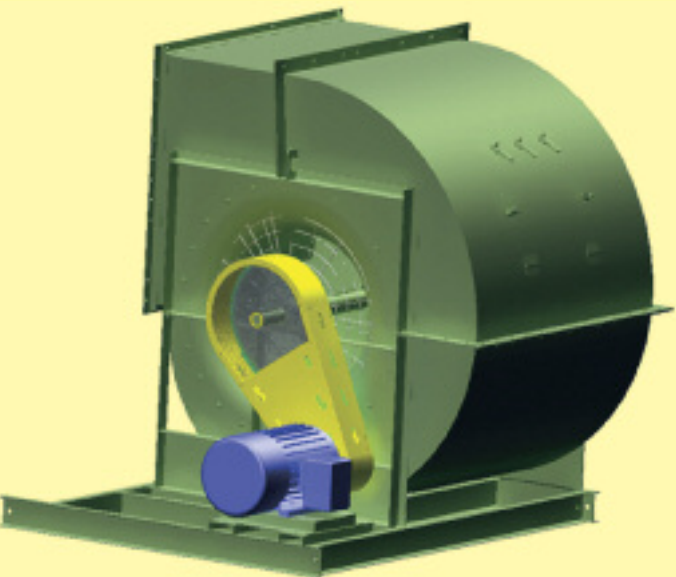

Size 44 Class 2 fan with split housing construction, inlet guard, quick-opening cleanout door, unitary base, belt guard, motor, and v-belt drive.

1. UNITARY BASE

Structural-steel base provides common support for fan, motor, and drive components...also available with **spring isolators**, or **rubber-in-shear isolators** [not shown]. Flexible outlet connection required when isolation is used.

2. DRAIN

1½" threaded tank flange located at lowest point in housing scroll.



3. INTERNAL INLET-VANE DAMPERS

Allows smooth control in systems that require efficient dampening of airflow. Dampers are an integral part of the fan inlet cones, providing considerable space-saving. See separate Engineering Supplement for performance.

4. FLANGED OUTLET

Angles are welded flush with fan outlet and provided with holes.

5. CLEANOUT DOOR

Two types of gasketed doors are available...**quick-opening:** latch-type door swings open on hinges after turning cam levers...**bolted:** closely spaced studs keep door securely sealed.

6. SPLIT HOUSING

Sizes 40 and larger Class 1 and 2, Sizes 36 and larger Class 3 available with split housings...bars are welded to housing to permit bolting sections together. Inlet and outlet connections do not have to be removed except outlet connections must be removed on Up Blast fans.

TYPE A Horizontal Split			
TYPE B Pie-shaped Split			
	Bottom Horizontal	Down Blast	Up Blast
	Top Horizontal	Top Angular Down	Bottom Angular Up
			Top Angular Up

7. SAFETY EQUIPMENT

Belt guards, inlet guards, and outlet guards are available.

OUTLET DAMPERS

Parallel-blade or opposed-blade outlet dampers are available for volume-control applications. See separate Catalog Sheet and Engineering Letter.



Parallel blade



Opposed blade

DOUBLE-WIDTH ACOUSTAFOIL FANS AND VARIABLE AIRFLOW APPLICATIONS

The rising cost of energy puts emphasis on air-handling systems that can be operated efficiently at less than maximum design airflow. The high efficiency and inherent stability of **nyb's** AcoustaFoil wheel is particularly well-suited to variable airflow systems such as industrial processes and variable volume air-conditioning systems. The AcoustaFoil wheel design ensures not only maximum operating efficiency at design CFM but also at reduced airflow regardless of the control method applied. This higher efficiency allows quieter operation throughout the modulation range.

Double-Width AcoustaFoil Fans are available with both parallel-blade and opposed-blade outlet dampers or internal inlet-vane dampers, and are suited to speed modulation using variable frequency motor speed controllers.

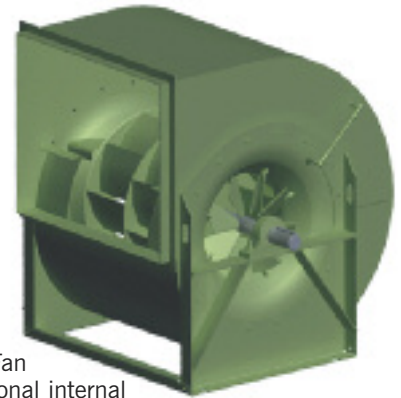

Size 24
Class 2 Fan
with optional internal
inlet-vane dampers [representative of
Sizes 18-27 Class 1 and 2 construction].

OUTLET DAMPER CONTROL

Outlet dampers act on air after it has passed through the fan by increasing resistance in the system. As the outlet damper is closed, the fan's point of operation moves left from the initial design point on the static-pressure curve. Depending on where the design point is, dampered horsepower may be less, the same, or more than the full flow of horsepower. Outlet dampers are typically the least expensive first cost option but also offer the least potential for energy savings.

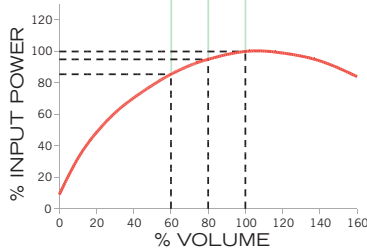
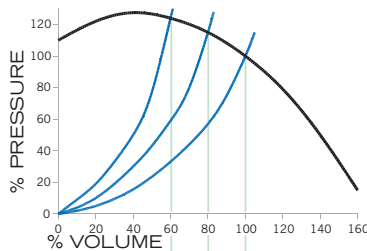

INLET-VANE DAMPER CONTROL

Inlet-vane dampers affect the fan's output by spinning the air in the direction of wheel rotation as it enters the fan. With this pre-spin, the wheel cannot develop its full output, yielding a reduced CFM at reduced horsepower. Each damper setting creates new pressure and horsepower curves. With inlet-vane dampers, reduced airflow always results in reduced horsepower. Though more expensive initially than outlet dampers, inlet-vane dampers offer greater potential for energy savings.

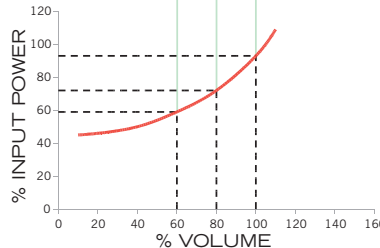
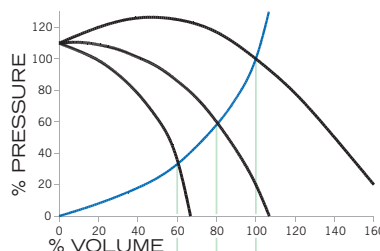

VARIABLE FREQUENCY MOTOR SPEED CONTROL

Variable frequency motor speed controllers provide energy savings by directly controlling fan speed. From the fan laws, CFM varies directly with the change in fan speed and horsepower varies by the change in fan speed cubed. For example, a 20% reduction in fan speed yields a 20% reduction in airflow and a 49% reduction in BHP. Though highest in first cost, variable frequency speed control provides the greatest potential for energy savings.

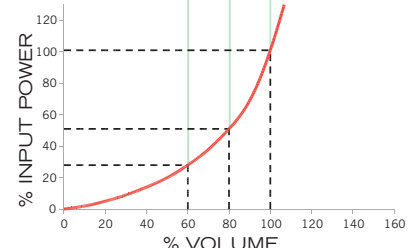
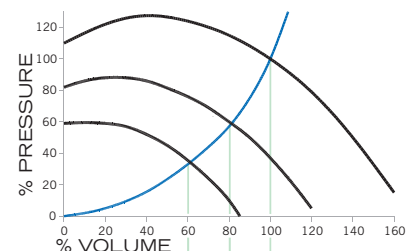

The decision to vary the fan's CFM by outlet damper, inlet-vane damper, or speed control should include consideration of the fan's duty cycle. Extended operation at less than full performance favors speed control because of its superior energy-savings potential despite its higher first cost. Infrequent operation at less than full performance favors outlet damper control because of its lower first costs relative to the limited energy-savings

potential. Inlet-vane damper control demands consideration in almost all instances as it offers good potential for energy savings at reasonable initial cost.

The New York Blower Company's nationwide network of trained sales engineers is familiar with each of these control alternatives and can offer further assistance in selecting the best control for a particular application.

DOUBLE-WIDTH ACOUSTAFOIL FAN SELECTION

HOW TO USE CAPACITY TABLES

For a given fan size, CFM, and static pressure, capacity tables are used to obtain outlet velocity, RPM, and BHP. If capacities are at conditions other than 70°F. and sea level [standard density, .075 lbs./cu. ft.], correction factors are applied to static pressure and BHP.

1. If conditions other than standard are involved, correct static pressure for actual altitude and temperature using Chart I.
2. Select size, RPM, and BHP from capacity tables, pages 7-13.
3. Determine actual performance at operating conditions by correcting static pressure and brake horsepower.

EXAMPLE: A fan is required for 16,000 CFM at 5"WG at 5000 ft. elevation at 70°F.

1. Chart I gives a 1.20 factor for 5000 ft. at 70°F. Corrected pressure is 5"WG x 1.20 = 6"WG at 70°F. at sea level.
2. A Size 241 is selected for 16,000 CFM at 6"WG at 1886 RPM and 20.8 brake horsepower.
3. Actual performance: 16,000 CFM at 5"WG [6" ÷ 1.20] at 1886 RPM at 17.3 BHP [20.8 ÷ 1.20] at 5000 ft. at 70°F.

On Sizes 181 through 731; Class 1 is to left of outline area, Class 2 is outline area, Class 3 is to right of outline area.

CHART I—CORRECTION FACTORS FOR TEMPERATURE AND ALTITUDE

Temperature °F.	Altitude-feet above sea level												
	0	500	1000	1500	2000	3000	4000	5000	6000	7000	8000	9000	10000
-50	.77	.785	.801	.816	.832	.862	.893	.924	.963	1.00	1.04	1.08	1.12
-25	.82	.836	.853	.869	.886	.918	.951	.984	1.03	1.07	1.11	1.15	1.19
0	.87	.887	.905	.922	.940	.974	1.01	1.04	1.09	1.13	1.18	1.22	1.26
20	.91	.928	.946	.965	.983	1.02	1.06	1.09	1.14	1.18	1.23	1.27	1.32
40	.94	.959	.978	.996	1.02	1.05	1.09	1.13	1.18	1.22	1.27	1.32	1.36
60	.98	.999	1.02	1.04	1.06	1.10	1.14	1.18	1.23	1.27	1.32	1.37	1.42
70	1.00	1.02	1.04	1.06	1.08	1.12	1.16	1.20	1.25	1.30	1.35	1.40	1.45
80	1.02	1.04	1.06	1.08	1.10	1.14	1.18	1.22	1.28	1.33	1.38	1.43	1.48
100	1.06	1.08	1.10	1.12	1.15	1.19	1.23	1.27	1.33	1.38	1.43	1.48	1.54
120	1.09	1.10	1.13	1.16	1.18	1.22	1.26	1.31	1.36	1.42	1.47	1.53	1.58

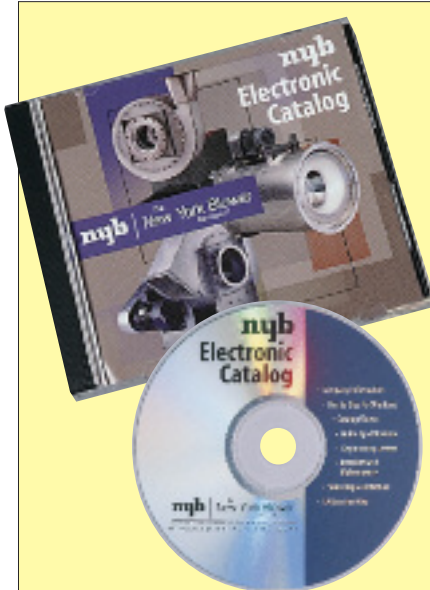

ELECTRONIC CATALOG

A complete New York Blower Catalog on one CD. No more manual calculations and bulky product catalogs. A critical tool for all system-designers and engineers who select and specify air-moving equipment.

SELECTION BENEFITS

- Fast, accurate fan selection.
- Automatic altitude, temperature, and density corrections.
- Sound levels by octave band.
- Fan-performance curves.
- Multiple model and size choices.
- Metric or English units.

CATALOG CONTENTS

- Fan-selection program.
- Complete product catalog in PDF including drawings, dimensions, and design specifications.
- Sample guide specifications.
- New York Blower Engineering Letters.
- Installation and Maintenance Manuals.
- Listing of New York Blower representatives.

To obtain your copy of New York Blower's Electronic Catalog contact your local New York Blower representative or go to www.nyb.com and click on *Selection Software*.

SIZE 101		Wheel diameter: 10" Wheel circumference: 2.62'										Fan outlet area: 1.02 sq. ft. Maximum BHP = $.034 \left(\frac{\text{RPM}}{1000}\right)^3$				Class 2 = 4900 RPM							
		CFM	OV	1"SP		1½"SP		2"SP		2½"SP		3"SP		3½"SP		4"SP		5"SP		6"SP		7"SP	
		RPM	BHP	RPM	BHP	RPM	BHP	RPM	BHP	RPM	BHP	RPM	BHP	RPM	BHP	RPM	BHP	RPM	BHP	RPM	BHP	RPM	BHP
1000	980	1991	0.52	2275	0.62	2564	0.74	2836	0.87	3102	1.02	3339	1.17	3570	1.33	3981	1.66	4358	2.01	4678	2.35	4767	3.16
1400	1373	2365	0.67	2602	0.79	2804	0.92	3005	1.05	3212	1.20	3415	1.36	3624	1.53	4004	1.89	4382	2.31	4733	2.79	4741	2.96
1600	1569	2552	0.76	2791	0.91	2986	1.05	3165	1.19	3339	1.33	3517	1.50	3698	1.67	4059	2.05	4398	2.45	4741	2.96	4741	2.96
1800	1765	2748	0.86	2976	1.03	3180	1.20	3354	1.36	3515	1.52	3664	1.67	3819	1.84	4143	2.23	4454	2.65	4767	3.16	4767	3.16
2000	1961	2953	0.98	3168	1.17	3365	1.36	3544	1.55	3700	1.72	3844	1.89	3979	2.06	4263	2.44	4554	2.92	4846	3.44	4846	3.44
2200	2157	3170	1.12	3363	1.33	3550	1.54	3726	1.75	3888	1.95	4033	2.14	4164	2.33	4424	2.75	4669	3.20				
2400	2353	3393	1.29	3567	1.50	3747	1.74	3913	1.96	4072	2.19	4223	2.41	4361	2.65	4600	3.10	4837	3.59				
2800	2745	3852	1.72	3999	1.94	4150	2.19	4304	2.46	4448	2.75	4594	3.06	4729	3.36								
3000	2941	4086	1.98	4224	2.21	4361	2.46	4506	2.78	4646	3.10	4786	3.43										
3200	3137	4324	2.27	4451	2.51	4582	2.82	4715	3.14	4841	3.46												
3400	3333	4563	2.61	4683	2.90	4802	3.20																

SIZE 121		Wheel diameter: 12¼" Wheel circumference: 3.21'										Fan outlet area: 1.55 sq. ft. Maximum BHP = $.101 \left(\frac{\text{RPM}}{1000}\right)^3$				Class 2 = 4800 RPM							
		CFM	OV	1"SP		2"SP		3"SP		4"SP		5"SP		6"SP		7"SP		8"SP		9"SP		10"SP	
		RPM	BHP	RPM	BHP	RPM	BHP	RPM	BHP	RPM	BHP	RPM	BHP	RPM	BHP	RPM	BHP	RPM	BHP	RPM	BHP	RPM	BHP
1800	1161	1742	0.70	2152	1.04	2559	1.47	2935	1.97	3263	2.49	3571	3.14	3842	3.80	4113	4.55	4349	5.27	4585	6.07	4585	6.07
2400	1548	2042	0.91	2392	1.33	2696	1.78	3005	2.30	3323	2.96	3605	3.64	3885	4.40	4148	5.21	4379	5.99	4617	6.88	4617	6.88
3000	1935	2353	1.20	2687	1.72	2960	2.25	3204	2.83	3453	3.52	3689	4.23	3939	5.04	4201	5.94	4422	6.77	4667	7.77	4667	7.77
3300	2129	2513	1.38	2843	1.96	3105	2.53	3342	3.20	3560	3.88	3783	4.63	3999	5.41	4231	6.30	4469	7.26	4684	8.19	4684	8.19
3600	2323	2676	1.58	2994	2.21	3256	2.88	3487	3.61	3691	4.32	3891	5.06	4096	5.88	4307	6.78	4499	7.64	4709	8.62	4709	8.62
3900	2516	2844	1.82	3150	2.49	3406	3.25	3631	4.03	3830	4.79	4030	5.62	4214	6.43	4399	7.29	4592	8.24	4782	9.22	4782	9.22
4200	2710	3020	2.09	3303	2.84	3557	3.66	3781	4.50	3975	5.31	4163	6.17	4341	7.03	4520	7.94	4697	8.88				
4500	2903	3197	2.40	3462	3.23	3714	4.12	3932	5.00	4126	5.88	4315	6.82	4482	7.70	4648	8.62						
4800	3097	3378	2.78	3622	3.66	3867	4.60	4087	5.56	4281	6.51	4459	7.46	4627	8.42	4781	9.35						
5400	3484	3745	3.70	3956	4.66	4181	5.71	4393	6.78	4581	7.82	4756	8.88										
5700	3677	3931	4.25	4129	5.24	4341	6.33	4543	7.43	4735	8.56												

SIZE 131		Wheel diameter: 13½" Wheel circumference: 3.53'										Fan outlet area: 1.89 sq. ft. Maximum BHP = $.233 \left(\frac{\text{RPM}}{1000}\right)^3$				Class 2 = 4245 RPM								
		CFM		1"SP		2"SP		3"SP		4"SP		5"SP		6"SP		7"SP		8"SP		9"SP		10"SP		
		RPM	BHP	RPM	BHP	RPM	BHP	RPM	BHP	RPM	BHP	RPM	BHP	RPM	BHP	RPM	BHP	RPM	BHP	RPM	BHP	RPM	BHP	
2000	1511	0.74	1921	1.45	2293	2.35	2623	3.38	2919	4.51	3191	5.73	3441	7.02	3674	8.38	3892	9.81	4099	11.3	4099	11.3	4099	11.3
2800	1764	1.21	2128	2.07	2439	3.03	2710	4.06	2979	5.25	3241	6.60	3482	8.02	3707	9.52	3920	11.1	4127	12.7	4127	12.7	4127	12.7
3600	2049	1.88	2372	2.94	2657	4.05	2909	5.22	3145	6.48	3361	7.79	3560	9.15	3773	10.7	3984	12.4	4183	14.2	4183	14.2	4183	14.2
4000	2206	2.32	2508	3.47	2778	4.67	3021	5.92	3246	7.24	3459	8.64	3657	10.1	3843	11.6	4017	13.1	4216	14.9	4216	14.9	4216	14.9
4400	2370	2.85	2649	4.07	2902	5.38	3141	6.72	3357	8.11	3560	9.56	3756	11.1	3940	12.7	4114	14.3	4279	16.0	4279	16.0	4279	16.0
4800	2537	3.47	2792	4.76	3038	6.16	3263	7.60	3475	9.08	3671	10.6	3857	12.2	4040	13.9	4212	15.6						
5200	2706	4.18	2938	5.53	3177	7.03	3391	8.57	3597	10.2	3790	11.8	3970	13.4	4141	15.1	4312	16.9						
5600	2877	4.99	3096	6.43	3319	8.00	3528	9.64	3720	11.3	3911	13.0	4088	14.8	4256	16.6								
6400	3223	6.96	3425	8.59	3610	10.3	3809	12.1	3992	14.0	4164	15.9	4332	17.8										
6800	3395	8.11	3592	9.85	3768	11.6	3952	13.5	4132	15.5	4301	17.5												
7200	3566	9.37	3761	11.3	3931	13.1	4098	15.0	4274	17.1														

SIZE 151		Wheel diameter: 15" Wheel circumference: 3.93'										Fan outlet area: 2.33 sq. ft. Maximum BHP = $.330 \left(\frac{\text{RPM}}{1000}\right)^3$				Class 2 = 3800 RPM							
		CFM	OV	1"SP		2"SP		3"SP		4"SP		5"SP		6"SP		7"SP		8"SP		9"SP		10"SP	
		RPM	BHP	RPM	BHP	RPM	BHP	RPM	BHP	RPM	BHP	RPM	BHP	RPM	BHP	RPM	BHP	RPM	BHP	RPM	BHP	RPM	BHP
2300	987	1374	0.86	1695	1.38	2051	2.05	2355	2.85	2623	3.79	2859	4.79	3085	5.88	3284	6.97	3487	8.19	3676	9.45	3676	9.45
2800	1202	1517	1.05	1812	1.61	2070	2.26	2368	3.15	2641	4.14	2890	5.24	3100	6.32	3308	7.53	3507	8.82	3688	10.1	3688	10.1
3800	1631	1799	1.52	2101	2.29	2330	3.13	2523	4.04	2705	4.99	2914	6.14	3127	7.36	3350	8.74	3553	10.1	3736	11.5	3736	11.5
4300	1845	1948	1.83	2241	2.73	2471	3.70	2667	4.71	2830	5.69	2999	6.81	3161	7.94	3352	9.29	3545	10.7	3736	12.2	3736	12.2
4800	2060	2103	2.20	2378	3.24	2614	4.36	2807	5.44	2975	6.53	3126	7.65	3277	8.87	3424	10.1	3576	11.5	3742	12.9	3742	12.9
5300	2275	2262	2.66	2522	3.83	2755	5.08	2951	6.28	3117	7.45	3275	8.70	3409	9.90	3547	11.2	3678	12.6				
5800	2489	2425	3.24	2669	4.49	2895	5.85	3093	7.21	3265	8.52	3414	9.79	3556	11.1	3687	12.5						
6300	2704	2590	3.91	2820	5.25	3035	6.69	3231	8.17	3405	9.63	3560	11.1	3702	12.5								
6800	2918	2758	4.67	2976	6.11	3180	7.64	3369	9.20	3546	10.8												
7800	3348	3101	6.55	3298	8.19	3479	9.85	3658	11.6														
8800	3777	3448	8.91	3626	10.7	3796	12.6																

Performance certified is for installation Type B: Free inlet, Ducted outlet. Power rating [BHP] does not include transmission losses. Performance ratings do not include the effects of appurtenances [accessories].

SIZE 161

Wheel diameter: 16½"
Wheel circumference: 4.32'

Fan outlet area: 2.82 sq. ft.
Maximum BHP = .563 $\left(\frac{RPM}{1000}\right)^3$

Class 2 = 3425 RPM

CFM	OV	1"SP		2"SP		3"SP		4"SP		5"SP		6"SP		7"SP		8"SP		9"SP		10"SP	
		RPM	BHP	RPM	BHP	RPM	BHP	RPM	BHP	RPM	BHP	RPM	BHP	RPM	BHP	RPM	BHP	RPM	BHP	RPM	BHP
2500	887	1089	0.80	1468	1.39	1791	2.10	2066	2.95	2304	3.93	2520	4.98	2726	6.13	2908	7.28	3087	8.54	3260	9.88
3100	1099	1188	0.94	1485	1.55	1796	2.31	2071	3.27	2307	4.30	2529	5.45	2730	6.65	2908	7.85	3090	9.21	3247	10.5
3700	1312	1300	1.12	1568	1.79	1806	2.54	2080	3.60	2318	4.72	2532	5.91	2734	7.19	2924	8.54	3089	9.83	3254	11.3
4300	1525	1409	1.33	1667	2.08	1882	2.93	2092	3.95	2322	5.13	2548	6.44	2739	7.74	2923	9.12	3102	10.6	3257	12.0
4900	1738	1517	1.57	1776	2.42	1982	3.42	2166	4.47	2345	5.59	2546	6.91	2746	8.31	2935	9.80	3100	11.3	3271	12.9
5500	1950	1634	1.86	1886	2.84	2085	3.95	2259	5.07	2425	6.27	2587	7.55	2755	8.91	2936	10.4	3110	12.0	3282	13.7
6100	2163	1757	2.21	1993	3.32	2190	4.51	2362	5.77	2520	7.04	2664	8.32	2811	9.73	2958	11.2	3111	12.7	3281	14.5
6700	2376	1881	2.62	2103	3.87	2303	5.18	2470	6.52	2615	7.84	2765	9.30	2896	10.7	3025	12.2	3157	13.7	3300	15.4
7300	2589	2010	3.15	2216	4.48	2412	5.90	2579	7.32	2724	8.77	2861	10.3	2992	11.8	3121	13.4	3236	14.9	3353	16.5
7900	2801	2140	3.75	2337	5.19	2521	6.69	2688	8.21	2833	9.76	2965	11.3	3090	12.9	3212	14.6	3329	16.2		
8500	3014	2274	4.44	2458	5.96	2632	7.56	2798	9.20	2944	10.8	3077	12.5	3198	14.2	3321	16.1				
9100	3227	2407	5.21	2582	6.83	2748	8.52	2906	10.3	3057	12.0	3186	13.8	3307	15.6						
9700	3440	2543	6.09	2708	7.79	2866	9.57	3016	11.4	3162	13.3	3296	15.1	3419	17.1						
10300	3652	2681	7.08	2838	8.87	2986	10.7	3132	12.7	3275	14.7	3404	16.6								
10900	3865	2819	8.16	2966	10.0	3112	12.0	3251	14.0	3385	16.1										
11500	4078	2959	9.37	3098	11.3	3236	13.4														

SIZE 181

Wheel diameter: 18¼"
Wheel circumference: 4.78'

Fan outlet area: 3.45 sq. ft.
Maximum BHP = .757 $\left(\frac{RPM}{1000}\right)^3$

Class 1 = 2380 RPM
Class 2 = 3105 RPM
Class 3 = 3915 RPM

CFM	OV	1"SP		2"SP		3"SP		4"SP		5"SP		6"SP		8"SP		10"SP		12"SP		14"SP	
		RPM	BHP	RPM	BHP	RPM	BHP	RPM	BHP	RPM	BHP	RPM	BHP	RPM	BHP	RPM	BHP	RPM	BHP	RPM	BHP
3000	870	971	0.88	1321	1.56	1607	2.38	1856	3.42	2079	4.57	2276	5.78	2632	8.45	2942	11.4	3232	14.6	3494	18.0
3900	1130	1087	1.10	1341	1.82	1628	2.76	1860	3.87	2078	5.13	2276	6.47	2626	9.33	2940	12.5	3224	15.9	3478	19.4
4800	1391	1206	1.37	1441	2.19	1642	3.17	1880	4.39	2095	5.75	2284	7.17	2622	10.2	2942	13.7	3209	17.1	3482	21.1
5700	1652	1331	1.70	1561	2.69	1744	3.81	1908	5.00	2105	6.41	2306	7.96	2643	11.2	2941	14.8	3217	18.6	3474	22.6
6600	1913	1462	2.11	1682	3.31	1859	4.57	2012	5.85	2156	7.23	2309	8.74	2655	12.2	2956	16.0	3225	20.0	3484	24.3
7500	2174	1597	2.61	1805	4.02	1980	5.45	2132	6.90	2269	8.37	2393	9.87	2663	13.3	2973	17.3	3246	21.5	3492	25.9
8400	2435	1739	3.30	1931	4.83	2102	6.43	2253	8.06	2384	9.64	2507	11.3	2738	14.8	2983	18.7	3256	23.0	3513	27.7
9300	2696	1884	4.11	2062	5.77	2226	7.52	2372	9.29	2503	11.1	2626	12.9	2845	16.5	3050	20.5	3269	24.7	3522	29.5
10200	2957	2033	5.08	2194	6.83	2353	8.75	2495	10.7	2626	12.6	2744	14.6	2959	18.5	3159	22.7	3340	26.9	3542	31.6
11100	3217	2186	6.21	2334	8.08	2483	10.1	2618	12.2	2750	14.3	2864	16.4	3080	20.7	3270	25.0	3448	29.5	3621	34.2
12000	3478	2339	7.51	2477	9.51	2614	11.6	2746	13.9	2869	16.1	2989	18.5	3197	23.0	3390	27.7	3565	32.5	3729	37.3
12900	3739	2494	9.00	2624	11.2	2750	13.4	2879	15.8	2999	18.2	3111	20.6	3321	25.6	3512	30.6	3678	35.5	3839	40.5
13800	4000	2652	10.7	2772	13.0	2891	15.3	3010	17.8	3127	20.4	3239	23.0	3441	28.2	3629	33.5	3800	38.9		
14700	4261	2808	12.6	2923	15.0	3033	17.5	3147	20.1	3260	22.8	3365	25.5	3564	31.0	3754	36.9				
15600	4522	2966	14.7	3074	17.3	3182	19.9	3285	22.6	3392	25.4	3493	28.2	3694	34.2	3876	40.2				
16500	4783	3125	17.1	3228	19.8	3329	22.6	3430	25.4	3530	28.3	3627	31.3	3820	37.5						

SIZE 201

Wheel diameter: 20¼"
Wheel circumference: 5.24'

Fan outlet area: 4.14 sq. ft.
Maximum BHP = 1.20 $\left(\frac{RPM}{1000}\right)^3$

Class 1 = 2125 RPM
Class 2 = 2735 RPM
Class 3 = 3510 RPM

CFM	OV	1"SP		2"SP		3"SP		4"SP		5"SP		6"SP		8"SP		10"SP		12"SP		14"SP	
		RPM	BHP	RPM	BHP	RPM	BHP	RPM	BHP	RPM	BHP	RPM	BHP	RPM	BHP	RPM	BHP	RPM	BHP	RPM	BHP
5000	1208	1023	1.35	1246	2.24	1488	3.44	1707	4.86	1899	6.37	2074	7.98	2392	11.5	2676	15.3	2937	19.5	3179	24.0
6000	1449	1125	1.67	1339	2.72	1514	3.95	1716	5.42	1913	7.05	2089	8.82	2400	12.6	2684	16.7	2936	21.0	3178	25.8
7000	1691	1231	2.05	1438	3.32	1604	4.67	1754	6.14	1922	7.82	2105	9.68	2409	13.6	2678	17.8	2940	22.6	3174	27.5
8000	1932	1342	2.51	1541	4.02	1705	5.57	1848	7.16	1978	8.81	2114	10.6	2427	14.8	2696	19.2	2944	24.1	3169	29.0
9000	2174	1455	3.12	1646	4.82	1806	6.54	1944	8.27	2067	10.0	2183	11.9	2430	16.0	2721	20.9	2958	25.7	3188	31.1
10000	2415	1576	3.89	1751	5.70	1909	7.62	2047	9.56	2165	11.4	2281	13.5	2488	17.5	2719	22.3	2979	27.6	3204	33.0
11000	2657	1699	4.78	1862	6.73	2013	8.82	2148	10.9	2267	13.0	2379	15.2	2582	19.6	2771	24.2	2973	29.2	3207	34.9
12000	2899	1823	5.81	1974	7.89	2118	10.1	2249	12.4	2370	14.7	2478	17.0	2678	21.7	2857	26.5	3023	31.5	3219	37.2
13000	3140	1951	7.01	2090	9.22	2229	11.6	2355	14.1	2473	16.5	2582	19.1	2775	24.0	2953	29.2	3118	34.5	3271	39.8
14000	3382	2082	8.41	2210	10.7	2338	13.2	2462	15.9	2577	18.5	2683	21.2	2875	26.5	3051	32.0	3209	37.5	3361	43.2
15000	3623	2212	9.97	2334	12.5	2455	15.1	2570	17.8	2682	20.7	2786	23.5	2977	29.2	3152	35.1	3310	40.9	3455	46.8
16000	3865	2343	11.7	2458	14.4	2570	17.1	2683	20.1	2790	23.0	2891	26.0	3086	32.3	3250	38.2	3408	44.5		
17000	4106	2476	13.7	2584	16.5	2691	19.4	2795	22.4	2899	25.5	3003	28.8	3187	35.3	3351	41.6	3509	48.3		
18000	4348	2608	15.9	2710	18.9	2813	22.0	2912	25.1	3011	28.3	3108	31.6	3292	38.5	3461	45.5				
19000	4589	2743	18.4	2839	21.5	2934	24.6	3032	28.0	3125	31.3	3220	34.9	3399	42.1						
20000	4831	2876	21.1	2970	24.4	3061	27.7	3151	31.1	3242	34.6	3331	38.2	3504	45.7						

Performance certified is for installation Type B: Free inlet, Ducted outlet. Power rating [BHP] does not include transmission losses. Performance ratings do not include the effects of appurtenances [accessories].

CFM		OV	1"SP		2"SP		3"SP		4"SP		5"SP		6"SP		8"SP		10"SP		12"SP		14"SP		
			RPM	BHP	RPM	BHP	RPM	BHP	RPM	BHP	RPM	BHP	RPM	BHP	RPM	BHP	RPM	BHP	RPM	BHP	RPM	BHP	RPM
SIZE 221		Wheel diameter: 22¼" Wheel circumference: 5.82'										Fan outlet area: 5.12 sq. ft. Maximum BHP = 2.02 $\left(\frac{\text{RPM}}{1000}\right)^3$				Class 1 = 1970 RPM Class 2 = 2570 RPM Class 3 = 3240 RPM							
5000	977	819	1.20	1117	2.28	1361	3.65	1568	5.20	1753	6.89	1923	8.73	2219	12.6	2475	16.8	2714	21.4	2921	26.1		
6300	1230	879	1.45	1136	2.64	1366	4.19	1571	5.90	1755	7.74	1922	9.70	2218	13.9	2482	18.6	2716	23.4	2936	28.7		
7600	1484	961	1.77	1180	3.11	1387	4.78	1583	6.67	1760	8.65	1927	10.8	2219	15.3	2484	20.2	2722	25.5	2938	31.1		
8900	1738	1060	2.20	1243	3.68	1427	5.46	1606	7.46	1779	9.66	1934	11.9	2220	16.6	2478	21.8	2715	27.4	2934	33.2		
10200	1992	1164	2.76	1322	4.39	1485	6.28	1644	8.34	1802	10.6	1948	13.0	2231	18.2	2490	23.8	2728	29.7	2941	35.8		
11500	2246	1273	3.48	1414	5.25	1557	7.23	1702	9.43	1842	11.8	1984	14.3	2248	19.7	2499	25.6	2725	31.7	2945	38.3		
12800	2500	1385	4.35	1515	6.29	1641	8.36	1769	10.6	1896	13.0	2026	15.7	2277	21.4	2515	27.5	2732	33.8	2945	40.7		
14100	2754	1498	5.33	1620	7.49	1733	9.66	1847	12.0	1964	14.6	2083	17.3	2314	23.1	2537	29.4	2755	36.3	2955	43.2		
15400	3008	1615	6.50	1727	8.84	1834	11.2	1936	13.6	2042	16.3	2151	19.1	2364	25.1	2575	31.7	2782	38.8	2980	46.1		
16700	3262	1732	7.84	1838	10.4	1938	13.0	2033	15.5	2129	18.2	2226	21.1	2424	27.3	2622	34.1	2812	41.2	3008	49.1		
18000	3516	1850	9.37	1950	12.1	2043	14.8	2134	17.6	2225	20.5	2312	23.4	2492	29.7	2680	36.8	2859	44.0	3040	52.0		
19300	3770	1969	11.1	2063	14.1	2151	17.0	2239	20.0	2322	22.9	2403	26.0	2574	32.6	2744	39.7	2918	47.4	3089	55.4		
20600	4023	2088	13.1	2178	16.2	2263	19.4	2346	22.5	2424	25.7	2501	28.8	2659	35.7	2817	42.9	2978	50.6	3138	58.8		
21900	4277	2209	15.3	2294	18.6	2376	22.0	2454	25.3	2528	28.6	2604	32.1	2750	39.1	2899	46.5	3048	54.4	3201	62.8		
23200	4531	2330	17.8	2411	21.2	2488	24.8	2564	28.4	2634	31.8	2705	35.4	2845	42.7	2985	50.4	3129	58.7				
24500	4785	2450	20.5	2528	24.2	2602	27.9	2676	31.8	2742	35.3	2812	39.2	2942	46.6	3074	54.5	3208	62.9				

CFM		OV	1"SP		2"SP		3"SP		4"SP		5"SP		6"SP		8"SP		10"SP		12"SP		14"SP		
			RPM	BHP	RPM	BHP	RPM	BHP	RPM	BHP	RPM	BHP	RPM	BHP	RPM	BHP	RPM	BHP	RPM	BHP	RPM	BHP	RPM
SIZE 241		Wheel diameter: 24½" Wheel circumference: 6.41'										Fan outlet area: 6.21 sq. ft. Maximum BHP = 3.43 $\left(\frac{\text{RPM}}{1000}\right)^3$				Class 1 = 1790 RPM Class 2 = 2335 RPM Class 3 = 2940 RPM							
7000	1127	793	1.63	1007	3.13	1225	4.97	1407	6.94	1571	9.11	1724	11.5	1991	16.5	2226	22.0	2447	28.1	2641	34.2		
8500	1369	865	2.07	1058	3.76	1233	5.64	1412	7.78	1577	10.1	1724	12.6	1988	17.9	2227	23.9	2445	30.3	2638	36.8		
10000	1610	944	2.61	1125	4.51	1279	6.55	1427	8.74	1582	11.2	1732	13.9	1994	19.5	2226	25.7	2439	32.3	2629	39.0		
11500	1852	1029	3.28	1196	5.34	1342	7.58	1474	9.95	1603	12.5	1738	15.2	1998	21.2	2233	27.7	2443	34.6	2638	42.0		
13000	2093	1119	4.07	1274	6.36	1413	8.78	1538	11.3	1654	14.0	1767	16.8	2002	22.9	2238	29.8	2449	37.1	2641	44.6		
14500	2335	1213	5.02	1354	7.50	1488	10.1	1605	12.8	1719	15.8	1820	18.6	2031	25.1	2240	32.0	2442	39.2	2640	47.3		
16000	2576	1308	6.10	1440	8.82	1564	11.6	1679	14.6	1785	17.6	1886	20.8	2072	27.3	2263	34.5	2452	42.0	2647	50.4		
17500	2818	1405	7.38	1530	10.3	1646	13.4	1755	16.5	1859	19.7	1956	23.1	2134	30.0	2301	37.2	2475	45.1	2659	53.8		
19000	3060	1505	8.86	1621	12.0	1728	15.2	1832	18.6	1933	22.0	2028	25.6	2204	33.0	2364	40.6	2520	48.6	2676	57.0		
20500	3301	1606	10.6	1715	13.9	1817	17.4	1917	21.0	2012	24.6	2101	28.2	2271	36.0	2429	44.2	2572	52.2	2725	61.4		
22000	3543	1706	12.5	1809	16.0	1906	19.7	1999	23.4	2089	27.3	2179	31.3	2345	39.5	2498	47.9	2641	56.6	2780	65.8		
23500	3784	1809	14.7	1907	18.4	1999	22.3	2089	26.4	2175	30.4	2260	34.6	2417	42.9	2571	52.0	2708	61.0	2841	70.4		
25000	4026	1911	17.1	2005	21.1	2094	25.2	2177	29.4	2258	33.6	2338	37.9	2496	47.0	2641	56.1	2779	65.8	2907	75.4		
26500	4267	2014	19.8	2104	24.0	2187	28.3	2270	32.8	2347	37.2	2426	41.9	2574	51.1	2714	60.6	2848	70.5				
28000	4509	2118	22.8	2203	27.2	2285	31.8	2361	36.3	2439	41.2	2513	46.0	2654	55.6	2791	65.5	2926	76.2				
29500	4750	2222	26.1	2303	30.7	2383	35.5	2455	40.3	2528	45.2	2598	50.2	2736	60.4	2871	70.9						

CFM		OV	1"SP		2"SP		3"SP		4"SP		5"SP		6"SP		8"SP		10"SP		12"SP		14"SP		
			RPM	BHP	RPM	BHP	RPM	BHP	RPM	BHP	RPM	BHP	RPM	BHP	RPM	BHP	RPM	BHP	RPM	BHP	RPM	BHP	RPM
SIZE 271		Wheel diameter: 27" Wheel circumference: 7.07'										Fan outlet area: 7.54 sq. ft. Maximum BHP = 5.77 $\left(\frac{\text{RPM}}{1000}\right)^3$				Class 1 = 1540 RPM Class 2 = 2010 RPM Class 3 = 2530 RPM							
7900	1048	671	1.73	906	3.45	1099	5.51	1269	7.86	1414	10.3	1553	13.1	1783	18.8	2000	25.5	2188	32.3	2362	39.8		
9800	1300	725	2.14	926	4.09	1109	6.37	1276	8.95	1418	11.6	1551	14.5	1789	20.7	1999	27.6	2186	34.8	2361	42.6		
11700	1552	793	2.67	963	4.85	1129	7.33	1287	10.1	1427	13.0	1557	16.1	1795	22.8	2007	30.1	2194	37.8	2370	46.0		
13600	1804	869	3.40	1015	5.75	1162	8.42	1304	11.3	1439	14.5	1568	17.8	1799	24.9	2004	32.4	2201	40.9	2369	49.2		
15500	2056	951	4.32	1081	6.86	1210	9.71	1338	12.8	1463	16.1	1582	19.6	1808	27.1	2018	35.4	2198	43.6	2376	52.9		
17400	2308	1036	5.41	1154	8.15	1268	11.2	1383	14.5	1495	17.9	1607	21.6	1826	29.7	2019	37.9	2202	46.7	2378	56.4		
19300	2560	1123	6.67	1231	9.67	1334	12.8	1439	16.4	1541	20.0	1642	23.8	1841	32.0	2040	41.2	2219	50.6	2385	60.2		
21200	2812	1211	8.11	1312	11.5	1407	14.8	1504	18.6	1596	22.3	1692	26.5	1879	35.2	2062	44.5	2231	54.0	2397	64.3		
23100	3064	1302	9.80	1396	13.5	1486	17.1	1572	20.9	1659	24.9	1747	29.3	1916	38.1	2085	47.7	2253	58.0	2412	68.6		
25000	3316	1393	11.7	1483	15.8	1566	19.7	1647	23.6	1725	27.8	1808	32.3	1965	41.6	2121	51.3	2283	62.3	2430	72.8		
26900	3568	1484	13.9	1570	18.3	1647	22.5	1725	26.7	1800	31.1	1873	35.7	2022	45.4	2171	55.8	2320	66.8	2463	78.1		
28800	3820	1576	16.4	1658	21.1	1732	25.6	1804	30.0	1875	34.6	1944	39.4	2082	49.4	2220	60.1	2362	71.6	2497	83.2		
30700	4072	1668	19.2	1748	24.2	1818	29.1	1887	33.9	1955	38.7	2020	43.6	2152	54.1	2282	65.3	2414	77.0				
32600	4324	1761	22.3	1837	27.5	1905	32.9	1972	38.1	2037	43.1	2098	48.1	2220	58.8	2343	70.3	2470	82.7				
34500	4576	1854	25.9	1928	31.3	1994	37.0	2059	42.6	2118	47.8	2177	53.1	2294	64.2	2411	76.1	2525	88.2				
36400	4828	1948	29.8	2020	35.4	2084	41.5	2144	47.3	2202	52.9	2259	58.6	2371	70.0	2482	82.2						

Performance certified is for installation Type B: Free inlet, Ducted outlet. Power rating [BHP] does not include transmission losses. Performance ratings do not include the effects of appurtenances [accessories].

SIZE 301

Wheel diameter: 30"
Wheel circumference: 7.85'

Fan outlet area: 9.31 sq. ft.
Maximum BHP = 9.76 $\left(\frac{RPM}{1000}\right)^3$

Class 1 = 1385 RPM
Class 2 = 1805 RPM
Class 3 = 2275 RPM

CFM	OV	1"SP		2"SP		3"SP		4"SP		5"SP		6"SP		8"SP		10"SP		12"SP		14"SP	
		RPM	BHP	RPM	BHP	RPM	BHP	RPM	BHP	RPM	BHP	RPM	BHP	RPM	BHP	RPM	BHP	RPM	BHP	RPM	BHP
10300	1106	613	2.17	818	4.42	992	7.06	1143	9.99	1274	13.1	1392	16.4	1605	23.7	1797	31.9	1974	40.9	2134	50.4
12600	1353	664	2.71	839	5.23	999	8.06	1148	11.3	1277	14.7	1401	18.4	1612	26.2	1801	34.7	1971	43.9	2123	53.3
14900	1600	726	3.45	873	6.16	1021	9.31	1157	12.7	1285	16.3	1405	20.3	1615	28.6	1800	37.4	1970	47.0	2130	57.4
17200	1847	794	4.38	924	7.33	1054	10.7	1178	14.3	1299	18.2	1414	22.4	1619	31.1	1810	40.9	1975	50.7	2136	61.7
19500	2095	867	5.52	982	8.68	1097	12.3	1209	16.1	1322	20.3	1429	24.7	1627	33.8	1815	44.1	1985	54.9	2134	65.6
21800	2342	943	6.88	1047	10.3	1149	14.1	1251	18.1	1353	22.5	1450	27.0	1643	36.9	1823	47.6	1989	58.7	2139	70.1
24100	2589	1020	8.44	1116	12.2	1209	16.1	1301	20.5	1395	25.2	1483	29.8	1660	39.9	1835	51.1	1997	62.8	2147	74.9
26400	2836	1098	10.2	1189	14.4	1275	18.6	1358	23.1	1442	27.9	1526	32.9	1693	43.7	1854	55.0	2008	67.0	2159	80.0
28700	3083	1178	12.3	1263	16.9	1343	21.3	1420	26.0	1499	31.2	1574	36.2	1728	47.4	1879	59.2	2028	71.8	2173	85.1
31000	3330	1258	14.6	1339	19.7	1413	24.4	1488	29.5	1557	34.5	1630	40.1	1771	51.6	1915	64.0	2054	76.9	2195	91.0
33300	3577	1339	17.3	1416	22.8	1487	28.0	1556	33.2	1622	38.5	1691	44.4	1821	56.1	1954	68.9	2086	82.4	2219	96.7
35600	3824	1420	20.3	1493	26.1	1561	31.8	1625	37.2	1688	42.8	1752	48.8	1877	61.3	2001	74.5	2123	88.1	2248	103
37900	4071	1501	23.7	1573	29.9	1637	36.0	1699	41.8	1758	47.6	1819	53.9	1934	66.6	2052	80.3	2169	94.6		
40200	4318	1583	27.5	1653	34.0	1714	40.5	1773	46.9	1830	53.0	1887	59.4	1998	72.6	2109	86.9	2219	102		
42500	4565	1665	31.7	1733	38.5	1792	45.5	1849	52.4	1904	58.8	1958	65.4	2064	79.2	2169	93.9	2272	109		
44800	4812	1747	36.4	1813	43.3	1871	50.9	1924	58.0	1979	65.2	2030	72.0	2132	86.3	2232	101				

SIZE 331

Wheel diameter: 33"
Wheel circumference: 8.64'

Fan outlet area: 11.3 sq. ft.
Maximum BHP = 15.7 $\left(\frac{RPM}{1000}\right)^3$

Class 1 = 1265 RPM
Class 2 = 1650 RPM
Class 3 = 2080 RPM

CFM	OV	1"SP		2"SP		3"SP		4"SP		5"SP		6"SP		8"SP		10"SP		12"SP		14"SP	
		RPM	BHP	RPM	BHP	RPM	BHP	RPM	BHP	RPM	BHP	RPM	BHP	RPM	BHP	RPM	BHP	RPM	BHP	RPM	BHP
12000	1065	553	2.47	743	5.25	901	8.42	1037	11.9	1161	15.8	1272	19.9	1462	28.5	1636	38.2	1795	48.6	1935	59.3
14800	1313	594	3.12	757	6.11	908	9.64	1043	13.5	1163	17.7	1271	22.0	1468	31.6	1639	41.8	1790	52.5	1940	64.6
17600	1562	649	3.98	790	7.25	926	11.0	1051	15.2	1169	19.7	1275	24.3	1469	34.5	1641	45.5	1799	57.4	1936	69.2
20400	1810	710	5.06	832	8.57	953	12.6	1067	16.9	1181	21.9	1283	26.8	1472	37.5	1648	49.5	1801	61.8	1939	74.3
23200	2059	776	6.36	884	10.2	992	14.5	1095	19.0	1198	24.1	1296	29.5	1478	40.7	1651	53.3	1799	65.8	1947	80.0
26000	2307	844	7.95	943	12.1	1037	16.6	1132	21.5	1225	26.7	1319	32.4	1492	44.3	1657	57.4	1810	71.1	1948	85.1
28800	2555	914	9.81	1003	14.3	1091	19.1	1175	24.1	1264	29.8	1348	35.6	1511	48.1	1666	61.4	1815	75.9	1954	90.8
31600	2804	986	12.1	1069	16.8	1148	21.9	1226	27.2	1306	33.1	1382	39.0	1539	52.3	1682	65.9	1830	81.4	1962	96.6
34400	3052	1059	14.7	1136	19.8	1209	25.1	1282	30.8	1354	36.8	1425	43.0	1570	56.7	1709	71.1	1840	86.0	1973	103
37200	3301	1132	17.6	1204	23.0	1273	28.7	1340	34.7	1409	41.1	1475	47.6	1608	61.6	1735	76.1	1868	92.5	1992	109
40000	3549	1206	21.0	1275	26.8	1339	32.8	1404	39.3	1464	45.6	1526	52.3	1652	67.0	1774	82.3	1895	98.6	2012	116
42800	3798	1279	24.7	1346	31.0	1408	37.4	1467	44.1	1526	50.9	1584	58.0	1701	73.1	1816	88.8	1927	105	2043	123
45600	4046	1354	29.0	1419	35.8	1475	42.3	1533	49.4	1589	56.6	1644	64.0	1752	79.4	1860	95.6	1968	113	2073	131
48400	4295	1430	33.9	1491	41.0	1547	48.0	1601	55.3	1652	62.7	1705	70.5	1809	86.6	1911	103	2011	121		
51200	4543	1507	39.3	1564	46.8	1617	54.0	1668	61.6	1718	69.4	1769	77.6	1867	94.4	1964	112	2063	130		
54000	4791	1583	45.3	1637	53.1	1690	60.9	1738	68.7	1785	76.7	1834	85.4	1928	103	2020	121				

SIZE 361

Wheel diameter: 36½"
Wheel circumference: 9.56'

Fan outlet area: 13.8 sq. ft.
Maximum BHP = 26.9 $\left(\frac{RPM}{1000}\right)^3$

Class 1 = 1110 RPM
Class 2 = 1450 RPM
Class 3 = 1825 RPM

CFM	OV	1"SP		2"SP		3"SP		4"SP		5"SP		6"SP		8"SP		10"SP		12"SP		14"SP	
		RPM	BHP	RPM	BHP	RPM	BHP	RPM	BHP	RPM	BHP	RPM	BHP	RPM	BHP	RPM	BHP	RPM	BHP	RPM	BHP
15000	1088	491	2.95	664	6.26	810	10.3	938	15.0	1048	19.9	1145	25.0	1324	36.5	1477	48.7	1622	62.4	1751	76.4
18400	1334	526	3.73	674	7.26	812	11.5	934	16.3	1048	21.8	1147	27.4	1325	39.7	1482	53.1	1622	67.2	1754	82.4
21800	1581	570	4.71	699	8.57	822	13.0	938	17.9	1045	23.5	1147	29.6	1326	42.8	1485	57.2	1622	71.8	1755	88.1
25200	1827	624	6.01	735	10.2	842	14.8	950	20.0	1050	25.6	1146	31.8	1324	45.6	1480	60.5	1621	76.3	1754	93.5
28600	2074	686	7.64	775	12.0	875	17.0	967	22.3	1063	28.3	1156	34.7	1326	48.8	1480	64.2	1625	81.3	1754	98.7
32000	2321	749	9.64	824	14.2	912	19.5	999	25.2	1085	31.5	1166	37.7	1331	52.2	1477	67.6	1617	84.7	1753	104
35400	2567	812	11.9	879	16.8	956	22.4	1036	28.4	1115	35.0	1191	41.7	1342	56.3	1484	72.0	1620	89.5	1748	108
38800	2814	875	14.6	940	20.0	1003	25.6	1077	32.1	1148	38.7	1220	45.8	1358	60.7	1496	77.3	1626	94.8	1754	114
42200	3060	933	17.4	1003	23.6	1057	29.4	1120	36.0	1190	43.2	1256	50.7	1384	66.1	1510	82.6	1634	101	1756	120
45600	3307	967	19.2	1066	27.7	1116	33.9	1171	40.6	1232	47.9	1297	56.0	1417	72.1	1536	89.4	1653	108	1766	127
49000	3553	1027	22.7	1129	32.3	1178	38.9	1226	45.9	1280	53.4	1338	61.5	1451	78.1	1562	95.8	1672	115	1783	135
52400	3800	1093	26.9	1193	37.4	1242	44.6	1284	51.7	1331	59.3	1383	67.6	1494	85.6	1598	104	1699	123	1805	144
55800	4046	1160	31.8	1254	42.7	1305	50.8	1346	58.4	1388	66.2	1432	74.2	1535	92.9	1636	112	1734	132		
59200	4293	1228	37.3	1312	48.3	1368	57.6	1409	65.7	1447	73.7	1487	82.2	1578	101	1677	121	1768	141		
62600	4540	1296	43.4	1356	53.1	1432	65.0	1472	73.6	1508	81.9	1544	90.5	1626	109	1719	131	1809	152		
66000	4786	1365	50.2	1392	57.1	1493	72.7	1535	82.1	1572	91.3	1606	100	1678	119	1761	140				

Performance certified is for installation Type B: Free inlet, Ducted outlet. Power rating [BHP] does not include transmission losses. Performance ratings do not include the effects of appurtenances [accessories].

CFM		OV	1"SP		2"SP		3"SP		4"SP		5"SP		6"SP		8"SP		10"SP		12"SP		14"SP	
			RPM	BHP	RPM	BHP	RPM	BHP	RPM	BHP	RPM	BHP	RPM	BHP	RPM	BHP	RPM	BHP	RPM	BHP	RPM	BHP
SIZE 401		Wheel diameter: 40¼" Wheel circumference: 10.5'										Fan outlet area: 16.8 sq. ft. Maximum BHP = 43.8 $\left(\frac{\text{RPM}}{1000}\right)^3$				Class 1 = 1005 RPM Class 2 = 1315 RPM Class 3 = 1655 RPM						
19000	1131	450	3.73	602	7.79	736	12.8	848	18.4	951	24.7	1040	31.0	1200	45.0	1345	60.7	1472	77.0	1584	93.6	
23000	1369	482	4.69	612	8.99	737	14.2	849	20.2	950	26.8	1038	33.6	1202	48.9	1346	65.5	1470	82.4	1586	101	
27000	1607	522	5.90	637	10.6	746	16.0	852	22.1	949	28.9	1040	36.4	1200	52.2	1342	69.5	1473	88.4	1587	107	
31000	1845	571	7.45	669	12.5	765	18.1	860	24.4	953	31.4	1040	38.9	1202	55.9	1343	74.0	1470	93.3	1590	114	
35000	2083	625	9.45	706	14.7	794	20.8	880	27.4	965	34.6	1046	42.2	1201	59.2	1340	78.0	1471	98.7	1588	120	
39000	2321	681	11.8	748	17.3	828	23.8	906	30.7	982	38.1	1059	46.1	1206	63.5	1340	82.3	1468	103	1585	126	
43000	2560	736	14.5	796	20.3	865	27.1	939	34.5	1009	42.3	1078	50.5	1213	67.9	1348	87.9	1469	109	1586	132	
47000	2798	791	17.5	849	24.1	908	31.0	976	38.9	1041	47.1	1105	55.5	1232	73.8	1356	93.7	1476	115	1589	138	
51000	3036	843	20.9	904	28.3	955	35.5	1012	43.3	1074	51.9	1135	60.9	1253	79.9	1370	100	1485	122	1594	146	
55000	3274	872	23.0	960	33.1	1007	40.7	1056	48.6	1112	57.6	1169	66.9	1280	86.6	1391	108	1499	131	1605	154	
59000	3512	923	27.0	1016	38.4	1061	46.5	1104	54.7	1153	63.8	1207	73.6	1312	94.0	1415	116	1513	138	1612	162	
63000	3750	981	31.8	1071	44.2	1115	52.9	1155	61.4	1197	70.5	1245	80.6	1345	102	1445	125	1540	148	1630	172	
67000	3988	1039	37.4	1125	50.5	1171	60.2	1208	69.1	1247	78.5	1290	88.8	1383	111	1477	134	1565	158			
71000	4226	1099	43.6	1178	57.2	1227	67.9	1263	77.5	1299	87.2	1336	97.4	1420	120	1512	145	1597	169			
75000	4464	1158	50.7	1222	63.3	1282	76.4	1320	86.9	1353	97.0	1387	107	1464	130	1548	155	1632	182			
79000	4702	1218	58.5	1246	67.1	1337	85.5	1375	96.7	1408	107	1439	118	1506	141	1587	167					

CFM		OV	1"SP		2"SP		3"SP		4"SP		5"SP		6"SP		8"SP		10"SP		12"SP		14"SP	
			RPM	BHP	RPM	BHP	RPM	BHP	RPM	BHP	RPM	BHP	RPM	BHP	RPM	BHP	RPM	BHP	RPM	BHP	RPM	BHP
SIZE 441		Wheel diameter: 44½" Wheel circumference: 11.6'										Fan outlet area: 20.5 sq. ft. Maximum BHP = 72.4 $\left(\frac{\text{RPM}}{1000}\right)^3$				Class 1 = 910 RPM Class 2 = 1190 RPM Class 3 = 1495 RPM						
20000	976	393	3.92	544	8.77	664	14.5	770	21.3	858	28.1	942	35.9	1087	52.3	1213	69.9	1327	88.8	1430	108	
25200	1229	418	5.03	547	10.1	666	16.4	767	23.3	859	31.2	941	39.4	1089	57.3	1214	76.1	1330	96.7	1436	119	
30400	1483	452	6.40	563	11.9	670	18.4	767	25.6	859	34.0	941	42.8	1090	62.2	1218	82.7	1331	104	1439	128	
35600	1737	495	8.17	592	14.2	683	20.9	775	28.6	859	36.8	940	46.0	1088	66.5	1214	87.8	1331	111	1439	136	
40800	1990	545	10.5	625	16.9	709	24.2	787	31.9	867	40.6	944	50.0	1085	70.5	1213	93.4	1334	119	1439	144	
46000	2244	598	13.4	662	20.0	738	27.7	812	36.3	881	44.9	953	54.6	1088	75.6	1216	99.5	1332	125	1438	152	
51200	2498	652	16.7	708	23.9	773	32.0	841	40.9	906	50.3	970	60.2	1097	81.8	1220	106	1328	131	1433	158	
56400	2751	705	20.6	758	28.4	813	36.9	875	46.4	933	55.9	995	66.6	1109	88.5	1225	113	1332	139	1437	167	
61600	3005	756	24.9	810	33.7	857	42.4	911	52.2	968	62.7	1025	73.9	1131	96.7	1239	122	1342	148	1443	178	
66800	3259	785	27.8	864	39.9	906	49.0	951	58.7	1003	69.7	1055	81.2	1158	106	1256	131	1352	158	1450	188	
72000	3512	834	32.8	918	46.7	958	56.6	996	66.5	1042	77.7	1091	89.9	1185	115	1280	142	1371	170	1458	198	
77200	3766	889	39.1	971	54.3	1011	65.1	1046	75.5	1086	86.9	1128	98.8	1220	126	1309	153	1392	182	1479	212	
82400	4020	946	46.5	1023	62.7	1065	74.6	1098	85.5	1132	97.0	1170	109	1253	136	1339	166	1420	195			
87600	4273	1003	54.7	1072	71.1	1118	84.6	1152	96.7	1183	109	1215	121	1293	149	1372	179	1451	210			
92800	4527	1060	64.0	1112	78.9	1172	96.0	1205	109	1235	121	1265	134	1331	162	1406	192	1483	225			
98000	4780	1118	74.4	1141	84.9	1224	108	1259	122	1288	135	1316	149	1376	177	1445	208					

CFM		OV	1"SP		2"SP		3"SP		4"SP		5"SP		6"SP		8"SP		10"SP		12"SP		14"SP	
			RPM	BHP	RPM	BHP	RPM	BHP	RPM	BHP	RPM	BHP	RPM	BHP	RPM	BHP	RPM	BHP	RPM	BHP	RPM	BHP
SIZE 491		Wheel diameter: 49" Wheel circumference: 12.8'										Fan outlet area: 24.9 sq. ft. Maximum BHP = 117 $\left(\frac{\text{RPM}}{1000}\right)^3$				Class 1 = 850 RPM Class 2 = 1105 RPM Class 3 = 1395 RPM						
25000	1004	359	4.91	493	10.8	604	18.0	698	26.0	781	34.7	855	44.0	987	64.0	1103	86.0	1204	108	1302	134	
32000	1285	386	6.41	500	12.7	604	20.3	697	29.0	779	38.5	855	48.7	986	70.3	1102	93.8	1207	119	1305	146	
39000	1566	423	8.40	520	15.4	612	23.3	699	32.2	778	42.0	852	52.8	989	77.1	1105	102	1209	129	1307	158	
46000	1847	470	11.1	550	18.6	629	27.0	707	36.2	785	46.8	854	57.7	984	82.2	1101	109	1207	138	1307	169	
53000	2129	522	14.6	586	22.5	657	31.6	727	41.5	794	52.1	863	64.0	987	88.9	1101	117	1208	148	1303	179	
60000	2410	576	18.9	629	27.3	692	37.1	754	47.6	815	58.8	875	70.6	995	97.0	1103	125	1206	156	1306	191	
67000	2691	630	23.9	678	33.2	729	43.2	786	54.4	842	66.3	896	78.7	1003	105	1111	135	1212	167	1306	201	
74000	2972	681	29.5	731	40.2	773	50.6	823	62.4	876	75.1	925	88.0	1023	116	1119	145	1218	179	1308	213	
81000	3253	713	33.8	785	48.4	823	59.6	865	71.5	910	84.4	959	98.6	1050	128	1138	158	1230	192	1316	227	
88000	3534	763	40.6	839	57.7	875	69.7	911	82.2	951	95.6	994	110	1081	141	1165	173	1248	208	1328	243	
95000	3815	819	49.3	893	68.1	929	81.5	961	94.4	995	108	1032	122	1115	155	1193	188	1269	223	1345	260	
102000	4096	876	59.5	944	79.2	983	94.2	1014	108	1043	122	1077	138	1152	171	1225	206	1296	241	1368	280	
109000	4378	934	71.2	992	90.9	1037	109	1067	124	1095	138	1123	154	1189	188	1259	224	1331	263			
116000	4659	992	84.4	1016	97.3	1091	124	1121	141	1148	156	1174	172	1230	206	1297	244	1365	284			
123000	4940	1050	99.4	1067	112	1143	141	1175	159	1201	176	1226	192	1278	227	1336	265					
130000	5221	1109	116	1123	128	1193	159	1229	179	1256	197	1280	215	1327	251	1379	289					

Performance certified is for installation Type B: Free inlet, Ducted outlet. Power rating [BHP] does not include transmission losses. Performance ratings do not include the effects of appurtenances [accessories].

SIZE 541

Wheel diameter: 54¼"
Wheel circumference: 14.2'

Fan outlet area: 30.5 sq. ft.
Maximum BHP = 195 $\left(\frac{\text{RPM}}{1000}\right)^3$

Class 1 = 750 RPM
Class 2 = 975 RPM
Class 3 = 1230 RPM

CFM	OV	1"SP		2"SP		3"SP		4"SP		5"SP		6"SP		8"SP		10"SP		12"SP		14"SP	
		RPM	BHP	RPM	BHP	RPM	BHP	RPM	BHP	RPM	BHP	RPM	BHP	RPM	BHP	RPM	BHP	RPM	BHP	RPM	BHP
35000	1148	336	6.92	447	14.3	546	23.5	629	33.6	705	45.0	771	56.6	889	82.0	996	110	1090	140	1179	172
42300	1387	360	8.67	456	16.6	548	26.1	629	36.7	704	48.8	773	62.0	891	88.9	998	119	1090	150	1181	185
49600	1626	390	10.9	474	19.6	555	29.3	633	40.5	705	52.9	770	66.0	893	96.1	997	127	1092	161	1181	197
56900	1866	427	13.8	498	23.0	571	33.6	641	45.0	709	57.8	771	71.1	889	101	994	134	1089	170	1183	209
64200	2105	467	17.5	526	27.0	592	38.4	654	50.2	716	63.2	777	77.2	890	108	995	143	1089	179	1176	218
71500	2344	509	21.8	557	31.8	618	43.9	675	56.6	731	70.0	787	84.5	896	116	997	151	1090	189	1179	230
78800	2584	550	26.9	595	37.6	645	49.9	699	63.5	751	77.7	802	92.5	902	125	1001	161	1093	200	1177	240
86100	2823	591	32.5	634	44.4	676	56.8	725	70.9	775	86.4	821	102	914	134	1005	170	1096	211	1177	252
93400	3062	629	38.5	676	52.4	712	65.2	755	80.0	801	95.7	844	112	932	147	1016	183	1104	224	1183	266
100700	3302	650	42.5	717	61.2	751	74.9	787	89.6	829	106	871	123	952	159	1032	197	1112	238	1189	281
108000	3541	690	49.9	759	71.0	791	85.5	823	101	859	117	899	135	976	172	1053	213	1126	254	1199	297
115300	3780	733	58.9	800	81.7	832	97.6	862	113	894	131	927	148	1003	188	1073	228	1143	271	1213	316
122600	4020	776	69.2	840	93.3	874	111	902	127	930	145	961	163	1029	203	1097	245	1165	290	1229	335
129900	4259	821	80.9	878	105	916	125	943	143	968	160	996	180	1058	220	1125	265	1186	309		
137200	4498	865	93.8	910	116	957	141	985	160	1009	178	1033	197	1088	238	1152	285	1212	331		
144500	4738	910	108	930	124	997	158	1026	178	1051	198	1073	218	1122	259	1181	306				

SIZE 601

Wheel diameter: 60"
Wheel circumference: 15.7'

Fan outlet area: 37.3 sq. ft.
Maximum BHP = 323 $\left(\frac{\text{RPM}}{1000}\right)^3$

Class 1 = 675 RPM
Class 2 = 880 RPM
Class 3 = 1110 RPM

CFM	OV	1"SP		2"SP		3"SP		4"SP		5"SP		6"SP		8"SP		10"SP		12"SP		14"SP	
		RPM	BHP	RPM	BHP	RPM	BHP	RPM	BHP	RPM	BHP	RPM	BHP	RPM	BHP	RPM	BHP	RPM	BHP	RPM	BHP
50000	1340	321	10.2	411	19.8	494	31.1	569	44.3	637	58.9	699	74.6	805	107	902	144	986	181	1062	221
60000	1609	350	13.1	428	23.7	500	35.4	571	49.1	637	64.4	697	80.7	807	117	901	155	988	196	1066	239
70000	1877	388	17.1	452	28.4	516	41.2	580	55.3	639	70.3	698	87.3	804	124	899	165	985	208	1067	255
80000	2145	429	22.2	480	34.1	538	47.8	594	62.6	650	78.7	704	96.0	806	134	899	176	988	223	1066	271
90000	2413	471	28.3	514	40.9	564	55.4	616	71.5	665	87.9	715	106	812	145	901	188	987	235	1066	285
100000	2681	512	35.5	552	49.4	595	64.5	641	81.1	688	99.2	733	118	820	157	907	202	988	249	1066	301
110000	2949	553	43.6	593	59.4	628	74.7	670	92.5	713	112	753	131	835	173	916	218	994	266	1068	318
120000	3217	582	50.4	635	70.8	666	87.2	701	105	741	125	779	146	854	189	928	235	1003	285	1075	338
130000	3485	615	58.6	677	83.7	707	102	736	120	769	140	806	161	878	208	947	255	1014	305	1082	359
140000	3753	658	70.7	719	98.4	748	117	775	137	803	157	836	179	903	227	969	278	1032	329	1096	384
150000	4021	702	84.8	759	114	790	135	816	156	841	177	868	199	931	249	993	301	1053	355		
160000	4290	747	101	798	131	833	156	858	178	880	199	904	222	961	273	1020	327	1076	382		
170000	4558	792	119	822	142	874	178	899	201	921	223	943	247	992	298	1046	353	1104	414		
180000	4826	838	139	854	158	916	201	941	226	963	251	983	275	1027	327	1078	385				
190000	5094	883	162	895	180	955	225	984	255	1005	281	1025	306	1064	359	1108	415				
200000	5362	929	187	939	205	992	250	1025	284	1047	312	1067	340	1104	394						

SIZE 661

Wheel diameter: 66"
Wheel circumference: 17.3'

Fan outlet area: 45.1 sq. ft.
Maximum BHP = 519 $\left(\frac{\text{RPM}}{1000}\right)^3$

Class 1 = 615 RPM
Class 2 = 800 RPM
Class 3 = 1010 RPM

CFM	OV	1"SP		2"SP		3"SP		4"SP		5"SP		6"SP		8"SP		10"SP		12"SP		14"SP	
		RPM	BHP	RPM	BHP	RPM	BHP	RPM	BHP	RPM	BHP	RPM	BHP	RPM	BHP	RPM	BHP	RPM	BHP	RPM	BHP
70000	1552	313	15.1	384	27.4	453	41.6	518	57.9	578	76.1	635	96.4	732	138	821	185	897	233	968	284
80000	1774	338	18.6	402	32.1	463	47.1	522	63.4	581	82.5	633	102	733	147	818	195	897	246	970	301
90000	1996	368	23.2	422	37.2	478	53.3	532	70.8	584	89.1	637	110	731	155	816	205	897	260	969	317
100000	2217	400	28.7	444	43.3	496	60.3	545	78.3	593	97.6	641	119	734	165	820	218	898	274	968	331
110000	2439	431	35.0	470	50.4	516	68.1	561	87.2	607	108	651	129	736	176	820	229	894	284	969	348
120000	2661	463	42.3	499	58.7	537	76.8	581	97.4	622	118	664	141	744	189	822	241	899	301	968	361
130000	2882	493	50.2	529	68.4	563	87.1	602	108	641	130	680	154	756	204	829	257	901	315	971	379
140000	3104	521	58.3	561	79.3	591	98.9	625	121	662	144	697	168	769	220	838	275	909	336	974	398
150000	3326	537	63.6	593	91.9	620	112	650	134	682	157	718	183	785	237	850	293	914	353	978	418
160000	3548	567	74.0	624	105	651	127	677	149	707	174	738	200	803	256	865	315	924	374	988	443
170000	3769	600	86.3	655	120	682	143	707	167	732	191	761	218	823	277	882	337	939	400	995	465
180000	3991	633	100	686	136	714	161	736	185	760	211	785	237	843	297	900	361	953	424	1007	491
190000	4213	667	116	715	152	745	181	768	207	789	233	812	260	865	321	920	386	972	452		
200000	4435	701	133	742	168	777	202	799	229	820	256	840	284	889	347	941	414	992	483		
210000	4656	735	152	754	177	808	224	831	254	851	282	870	311	913	373	961	440				
220000	4878	769	173	783	196	839	248	863	281	883	311	901	340	939	401	985	472				

Performance certified is for installation Type B: Free inlet, Ducted outlet. Power rating [BHP] does not include transmission losses. Performance ratings do not include the effects of appurtenances [accessories].

SIZE 731

Wheel diameter: 73"
Wheel circumference: 19.1'

Fan outlet area: 55.2 sq. ft.
Maximum BHP = 860 $\left(\frac{\text{RPM}}{1000}\right)^3$

Class 1 = 555 RPM
Class 2 = 725 RPM
Class 3 = 915 RPM

CFM	OV	1"SP		2"SP		3"SP		4"SP		5"SP		6"SP		8"SP		10"SP		12"SP		14"SP	
		RPM	BHP	RPM	BHP	RPM	BHP	RPM	BHP	RPM	BHP	RPM	BHP	RPM	BHP	RPM	BHP	RPM	BHP	RPM	BHP
80000	1449	273	16.8	342	31.4	408	48.5	467	68.0	524	90.5	574	114	661	164	743	221	812	278	874	337
93000	1685	296	21.0	356	36.7	414	54.7	471	75.2	524	97.5	574	122	664	177	741	234	812	296	877	361
106000	1920	324	26.4	374	43.2	427	62.6	478	83.5	526	106	574	131	660	186	741	248	811	313	875	379
119000	2156	354	33.1	395	50.6	443	71.2	490	93.5	534	117	579	143	664	200	742	263	811	330	876	401
132000	2391	384	41.2	420	59.5	462	81.0	505	105	546	129	586	155	667	214	740	276	809	344	874	419
145000	2627	414	50.3	447	70.3	483	92.6	523	118	561	143	598	170	671	228	745	295	810	363	873	437
158000	2862	444	60.6	476	82.6	507	105	542	131	579	159	613	187	683	249	750	314	813	383	877	461
171000	3098	471	71.2	506	96.7	533	120	564	147	598	175	630	205	694	267	759	337	821	410	881	487
184000	3333	486	78.3	537	113	562	138	588	165	619	194	650	225	711	292	770	361	829	436	885	512
197000	3569	516	91.9	567	131	591	157	615	185	642	215	671	248	728	316	782	386	838	463	894	545
210000	3804	547	108	597	150	622	179	643	207	666	238	692	271	747	342	801	418	852	496	903	577
223000	4040	579	127	626	170	652	202	673	233	693	264	716	297	767	371	817	447	868	530	915	611
236000	4275	612	148	654	192	682	229	702	260	722	293	742	326	788	401	836	479	883	562		
249000	4511	645	171	677	211	712	256	733	291	751	324	769	359	811	435	857	517	901	600		
262000	4746	677	197	692	225	742	287	764	324	781	360	798	395	835	471	877	553				
275000	4982	710	225	721	252	771	318	794	359	811	396	828	433	862	510	901	596				

Performance certified is for installation Type B: Free inlet, Ducted outlet. Power rating [BHP] does not include transmission losses. Performance ratings do not include the effects of appurtenances [accessories].

MATERIAL SPECIFICATIONS

Dimensions in inches. Weights in pounds. WR² in lb.-ft.².

Size	Shaft diameter						Bearings			Drive key [square]			Wheel WR ² [lb.-ft. ²]			Bare fan weight [lbs.]		
	Class 1		Class 2		Class 3		Class	Class	Class	Class	Class	Class	Class	Class	Class	Class	Class	Class
	Wheel	Bearing	Wheel	Bearing	Wheel	Bearing	1	2	3	1	2	3	1	2	3	1	2	3
101	—	—	1	1	—	—	—	A	—	—	1/4	—	—	0.8	—	—	65	—
121	—	—	1 3/16	1 3/16	—	—	—	A	—	—	1/4	—	—	1.8	—	—	90	—
131	—	—	1 7/16	1 7/16	—	—	—	A	—	—	3/8	—	—	2.8	—	—	114	—
151	—	—	1 7/16	1 7/16	—	—	—	A	—	—	3/8	—	—	3.8	—	—	144	—
161	—	—	1 11/16	1 11/16	—	—	—	A	—	—	3/8	—	—	12	—	—	197	—
181	1 11/16	1 11/16	1 15/16	1 15/16	2 3/16	2 3/16	H	H	E	3/8	1/2	1/2	19	19	22	265	275	440
201	1 11/16	1 11/16	1 15/16	1 15/16	2 7/16	2 7/16	H	H	E	3/8	1/2	5/8	28	28	35	292	306	510
221	1 15/16	1 15/16	2 3/16	2 3/16	2 7/16	2 7/16	H	H	E	1/2	1/2	5/8	40	40	48	360	375	590
241	2 3/16	2 3/16	2 7/16	2 7/16	2 15/16	2 3/16	H	H	F	1/2	5/8	1/2	64	64	81	460	475	845
271	2 3/16	2 3/16	2 7/16	2 7/16	2 15/16	2 3/16	A	C	F	1/2	5/8	1/2	93	93	115	530	575	880
301	2 7/16	2 7/16	2 11/16	1 15/16	3 7/16	2 7/16	A	F	F	5/8	1/2	5/8	149	149	179	790	835	1065
331	2 7/16	2 7/16	2 15/16	2 3/16	3 7/16	2 7/16	A	F	F	5/8	1/2	5/8	219	220	251	925	1000	1325
361	2 11/16	2 11/16	2 15/16	2 3/16	3 15/16	2 11/16	A	F	F	5/8	1/2	5/8	363	363	417	1180	1225	2200
401	2 15/16	2 15/16	3 7/16	2 7/16	3 15/16	2 11/16	A	F	F	3/4	5/8	5/8	534	535	605	1345	1445	2350
441	3 7/16	2 7/16	3 15/16	2 11/16	4 7/16	2 15/16	F	F	F	5/8	5/8	3/4	872	874	1102	1730	1840	2750
491	3 7/16	2 11/16	4 7/16	2 15/16	4 15/16	3 7/16	F	F	F	5/8	3/4	7/8	1356	1406	2032	2205	2380	3350
541	3 15/16	2 15/16	4 7/16	3 7/16	5 7/16	3 15/16	F	F	F	3/4	7/8	1	2019	2096	3230	2820	2955	4300
601	3 15/16	2 15/16	4 15/16	3 7/16	5 7/16	4 7/16	F	F	F*	3/4	7/8	1	3068	3189	4756	3550	3855	4540
661	4 7/16	3 7/16	5 7/16	3 15/16	6	4 7/16	F	F	F*	7/8	1	1	5821	6008	7985	4585	4980	6960
731	4 15/16	3 15/16	6	3 15/16	6 1/2	4 15/16	F	F	F*	1	1	1 1/4	9374	9627	12918	7155	7465	10000

Shafting: AISI 1040 turned, ground, polished and straightened. Bearing types: A—Link-Belt P3-U200. C—Sealmaster SPM. E—Link-Belt P-U300. F—Link-Belt P-B22400. F*—Link-Belt P-B22500. H—Dodge GTAH Grip-Tight. **nyb** reserves the right to substitute bearings of equal ratings.



PLENUM FANS

Unhoused, single-width, Plenum Fans are available for airflows to 150,000 CFM and pressures to 12" WG. Nineteen sizes are offered from 12" to 73" wheel diameters. Designs include belt and direct-drive arrangements.

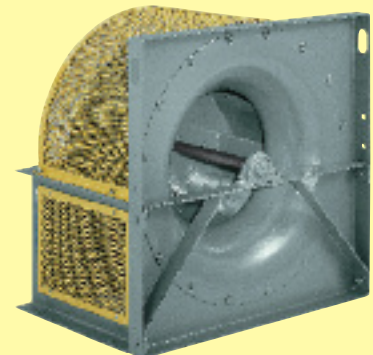

DIMENSIONS

ROTATABLE FANS

Dimensions should not be used for construction unless certified.

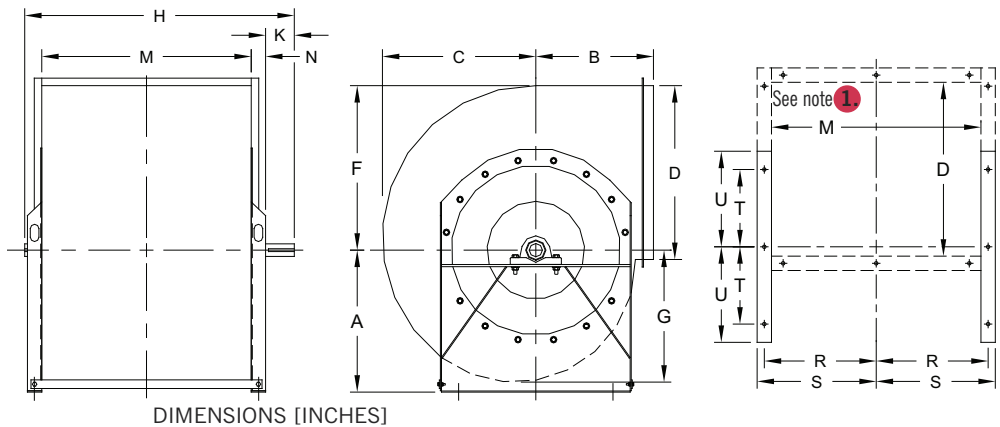

DIMENSIONS [INCHES]

Size	A			B*		C	D	F	G	H			K		M
	Class 1, 2		Class 3	▲	TAD					Class 1	Class 2	Class 3	Class 1, 2	Class 3	
	TH, TAD, DB	BH, UB, TAU, BAU													
101	9½	11¼	—	8½	8½	10½	11½	10⅝	8½	—	21¼	—	3	—	13⅝
121	11	13¾	—	10	10	12¾	13⅝	13	10⅝	—	24¼	—	3	—	16⅝
131	12	15	—	11	11	13⅝	15½	14¼	11⅝	—	26½	—	3	—	18¾
151	14	16¾	—	12	12	15½	16¾	15⅞	12⅝	—	28½	—	3½	—	20¼
161	14¾	18½	—	13	13	16⅝	18½	17½	14	—	30½	—	3½	—	22¼
181	16¼	20¼	21¼	14	14	18½	20½	19⅝	15½	34¼	34¼	37	3½	4	24¾
201	17¾	22¼	23¼	15½	15½	20⅝	22½	21⅝	17	37	37	40	4	4½	27
221	19¾	24½	25½	17	17	22½	24⅞	23⅝	18⅞	40⅞	40⅞	43	4	4½	30⅞
241	21½	26¾	28	19	19	24¾	27⅝	26	20¾	44¾	44¾	47	4½	5	33¼
271	23¾	29½	30½	20½	20½	27¼	30¼	28⅝	22⅞	48½	48½	50½	5	5½	36½
301	—	—	33¾	22½†	33	30⅝	33½	31⅞	25⅝	—	—	55½	—	6	40½
331	—	—	37	24½†	36	33⅝	36⅞	35	28	—	—	60	—	6½	44⅝
361	—	—	—	29†	40½	36⅞	40¾	38¾	30⅞	—	—	—	—	—	49¼

* For DB Discharge on Class 1 and 2 fans sizes 101-271, use A dimension for B. + For DB Discharge on Class 1 and 2 fans sizes 301-361, use B dimension for A.
† Use TAD dimension for Class 1 and 2 TAU and BAU discharge fans. ▲ TH, BH, UB, DB, BAU, TAU discharges. D and M are outside dimensions.

Size	N		R		S		T	U		a	b◇	c	d	Base holes
	Class 1, 2	Class 3	Class 1, 2	Class 3	Class 1, 2	Class 3		Class 1, 2	Class 3					
101	2¼	—	7⅞	—	8¾	—	4⅝	6⅝	—	9½	13⅝	10½	7⅝	⅑/16
121	2¼	—	9⅝	—	10¼	—	5⅞	8	—	11⅝	16¼	12⅞	9¼	⅑/16
131	2¼	—	10¾	—	11⅝	—	6⅝	8¾	—	12¾	17⅞	14	10¼	⅑/16
151	2¼	—	11½	—	12⅝	—	7½	9⅝	—	14⅞	19¾	15¾	11⅝	⅑/16
161	2¼	—	12½	—	13⅝	—	8½	10½	—	15½	21⅝	17¼	12½	⅑/16
181	2¾	4⅞	14	14⅞	15⅝	15⅝	9⅝	11⅝	10⅞	17¼	23⅝	19⅞	13⅞	⅑/16
201	2¾	4⅞	15⅝	15¼	16¼	16¾	10⅞	12⅞	11¾	19	26½	21⅞	15¼	⅑/16
221	2¾	4⅞	16¾	16⅞	17⅞	18⅝	10⅞	13⅞	12⅝	21	28¾	23¼	16¾	⅑/16
241	3¼	4⅞	18¼	18⅞	19⅝	20⅞	12¼	15½	14⅝	23⅞	31⅞	25⅝	18½	¾
271	3¼	4⅞	20¼	20½	21½	22½	13⅝	16⅞	15½	25⅝	34¾	28¼	20⅞	¾
301	—	4¼	—	22½	—	24½	14⅞	—	16⅞	28¼	38⅝	31⅝	22⅝	¾
331	—	4¼	—	24⅝	—	26⅝	16	—	18¼	31⅞	42⅞	34⅝	25¼	¾
361	—	—	—	—	—	—	17½	—	—	34⅝	45⅞	38¼	27½	⅞

◇ For Size 30 and 33, Class 3 fans, dimensions for BAU or TAU discharge are 38½" and 42½", respectively.

Tolerance: ± 1/8"

FAN DISCHARGES – VIEWED FROM DRIVE SIDE

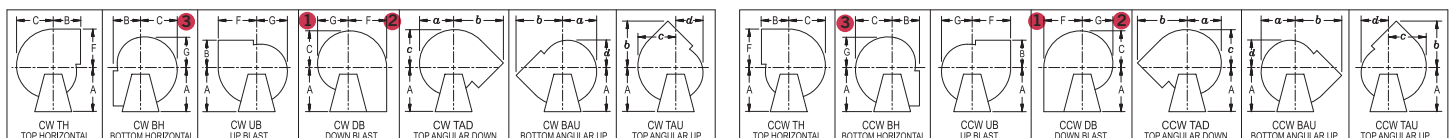

Clockwise—angular discharges at 45°

Counterclockwise—angular discharges at 45°

- ① Discharge is framed at floorline on Class 1 and 2 Down Blast fans.
- ② Discharge is framed at floorline on Class 3, Sizes 36-73 Down Blast fans. Class 3, Sizes 18-33 Down Blast fans are furnished standard with slip connection above floorline.
- ③ On Class 1 and 2 fans with Bottom Horizontal discharge and optional flanged outlet, the flange extends below the base bars of the fan.

The New York Blower Company has a policy of continuous product development and reserves the right to change designs and specifications without notice.

DIMENSIONS

Non-ROTATABLE FANS

Dimensions should not be used for construction unless certified.

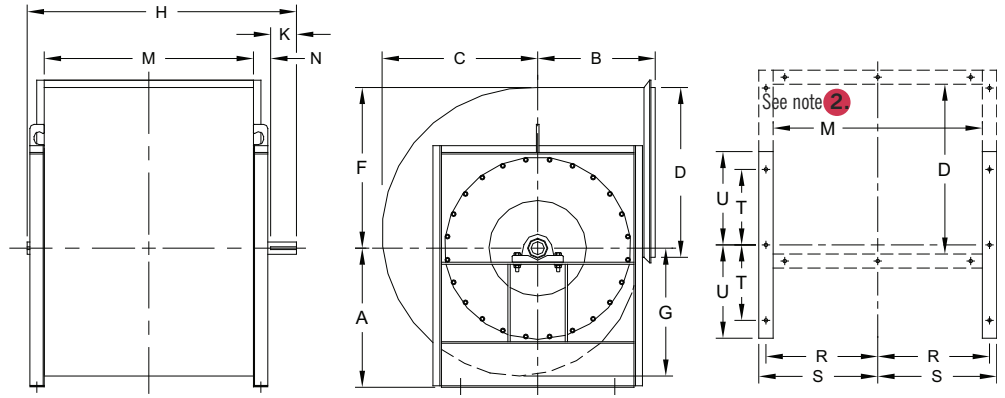

DIMENSIONS [INCHES]

Size	A†					B		C	D	F	G	H		K	
	Class 1, 2		Class 3			▲	TAD					Class 1, 2	Class 3	Class 1, 2	Class 3
	TH, TAD	BH, UB, TAU, BAU	TH, TAD	BH, BAU	UB, TAU										
301	26¼	33	—	—	—	22½	33	30¾	33½	31⅞	25¾	53	—	5 ½	—
331	28¾	36	—	—	—	24½	36	33¾	36⅞	35	28	57½	—	6	—
361	31¾	40	33	42	39	29	40½	36⅞	40¾	38¾	30⅞	62¾	67¼	6½	7
401	35	44	36	46	43	31	45¼	40¾	44⅞	42¾	34⅞	68¼	73	7	7½
441	38½	48¼	40	50	47	33½	49½	45	49⅝	47⅞	37¾	74½	79	7½	8
491	42½	53½	43½	55	51½	36	54	49½	54⅝	52	41½	83	86	8	8½
541	47	59	48	60½	57	40	60	54⅞	60¾	57½	45⅞	90½	94½	8½	9
601	52	65¼	53	66½	62½	43	66	60¾	66⅞	63¾	50⅞	98½	103¼	9	9½
661	57	71½	58	73	69	47	70¼	66¾	73½	70	56	107¼	111¾	9½	10
731	63	79	64	80½	76	51½	76½	73⅞	81¼	77½	61⅞	117	123¼	10	10½

† On DB discharge, use B for A. ▲ TH, BH, UB, DB, BAU, TAU discharges. D and M are outside housing dimensions.

Size	M	N		R		S		T	U		a	b		c	d	Base holes
		Class 1, 2	Class 3	Class 1, 2	Class 3	Class 1, 2	Class 3		Class 1, 2	Class 3		BAU, TAU	TAD			
		301	40½	3¼	—	22⅞	—		23½	—		14⅞	19			
331	44⅝	3¼	—	24¼	—	25⅝	—	16	20⅝	—	31⅞	42⅞	50¼	34⅝	25¼	¾
361	49¼	3¼	5⅝	26½	26⅞	27⅞	27⅞	17½	22⅞	24½	34¾	47⅞	56	38¼	27½	⅞
401	54⅝	3¼	5⅝	28¾	28¾	30¼	30¼	19	27½	26¼	38	52⅞	62¼	42⅞	30	⅞
441	60	3¼	5⅝	31½	31½	33	33	21	30	28¾	42	57	68¾	46½	33⅝	⅞
491	66⅞	4⅞	5½	34⅝	34⅝	36⅞	36⅞	23	32½	31¼	46⅞	62¼	75	51¼	36½	⅞
541	73⅞	4⅞	5⅞	38⅞	38⅞	40⅞	40⅞	25	36¼	35	51⅞	69	83⅞	56¾	41	1
601	80¾	4⅞	6¼	42¾	42¾	44¾	44¾	26½	39¾	38½	56⅝	75½	91⅝	61⅞	45¾	1
661	88⅞	4⅞	6¼	46½	46½	47	48½	29	43	42¼	62¼	82¾	99⅞	69⅞	49⅞	1
731	98¼	4⅞	7	51⅞	51⅞	53⅞	54⅞	33½	47	46¼	68⅞	91¼	108⅞	76¾	55⅞	1

Tolerance: ± 1/8"

FLANGED OUTLET OPTION

1. Mounted flush with outside edge of housing discharge.
2. Holes furnished on 4" centers from centerlines.
3. M and D dimensions are inside flange, outside housing.
4. Down Blast fans with optional flanged outlet are only offered in Class 3.
5. Tolerance: ± 1/8".

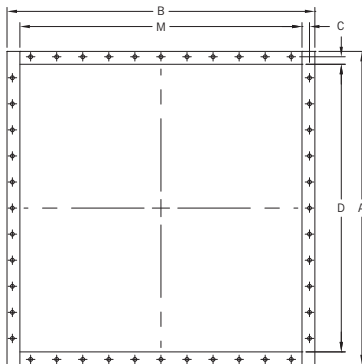

DIMENSIONS [INCHES]

Size	A	B	C	D	M	Hole dia.
101	13⅞	15⅝	5/8	11⅞	13⅝	5/16
121	15⅝	18⅝	5/8	13⅝	16⅝	5/16
131	17⅞	20¾	5/8	15⅞	18¾	5/16
151	18¾	22¼	5/8	16¾	20¼	5/16
161	21	24¾	3/4	18½	22¼	7/16
181	23	27¼	3/4	20½	24¾	7/16
201	25	29½	3/4	22½	27	7/16
221	27¾	32⅝	3/4	24⅞	30⅞	7/16
241	30¾	36¼	7/8	27¾	33¼	7/16
271	33¼	39½	7/8	30¼	36½	7/16
301	36½	43½	7/8	33½	40½	7/16
331	39⅞	47⅝	7/8	36⅞	44⅝	7/16
361	44¾	53¼	1⅞	40¾	49¼	9/16
401	48⅞	58¾	1⅞	44⅞	54¾	9/16
441	53⅝	64	1⅞	49⅝	60	9/16
491	58⅝	70⅞	1⅞	54⅝	66⅞	9/16
541	64¾	77⅞	1⅞	60¾	73⅞	9/16
601	70⅞	84¾	1⅞	66⅞	80¾	9/16
661	77½	92⅞	1⅞	73½	88⅞	9/16
731	85¼	102¼	1⅞	81¼	98¼	9/16

COMPLETE SELECTION OF AIR-MOVING EQUIPMENT

The New York Blower Company offers thousands of different types, models, and sizes of air-moving equipment. Contact your nyb representative for assistance in identifying the best fan for your application.

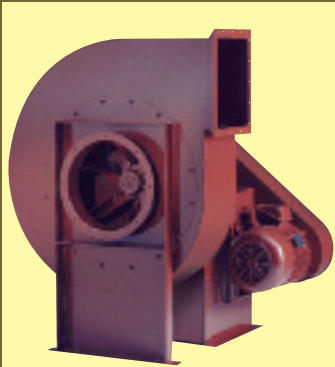

DUST/MATERIAL HANDLING

Wide range of duty available with unique fan lines capable of handling light dust to heavy material. Typical applications include dust-collection and high-pressure process along with material-conveying.



AIR-HANDLING [CENTRIFUGAL]

Designed for clean to moderately dirty gas streams. Commercial and industrial HVAC, process cooling, light material-conveying, heat removal, and dryer exhaust are just a few of the numerous sample applications



AIR-HANDLING [AXIAL]

For the ideal handling of clean to moderately dirty airstreams. Commercial and industrial HVAC, drying and cooling systems, fume extraction, and process-heat removal are typical applications.



FIBERGLASS REINFORCED PLASTIC [FRP]

Choice of performance and duty for corrosive gas streams. Applications include chemical process, wastewater treatment, laboratory hood exhaust, and tank aeration.

CUSTOM PRODUCTS

Designed for unique applications. Variety of configurations, temperatures, flows, and pressures. Wide range of modifications and accessories are available to meet the most demanding specifications.

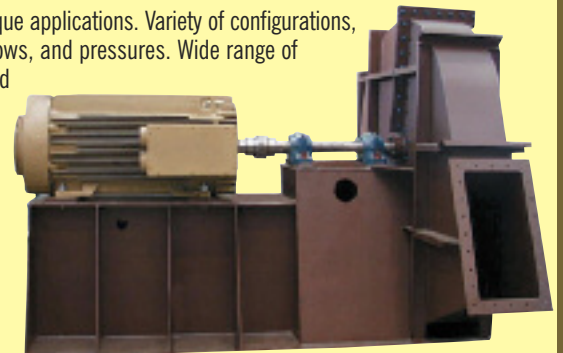

Leading the industry forward since 1889



ROOF VENTILATORS

Including both hooded and upblast ventilators, propeller fans, and centrifugal roof exhausters. These units are ideal for industrial, commercial, and institutional applications.



HEATING PRODUCTS

Industrial-duty steam unit heaters with steam heating coils are available for facility heating and process-heat transfer.



PROCESS/FAN COMPONENTS

Plug fans, plenum fans, wheels, inlet cones, and housings for a wide variety of OEM applications. Process/fan components are used in air-handling units, ovens, dryers, freezer tunnels, and filtration systems.