

CD50DC (DATA CENTER)

High-Performance Control Damper

Extruded Aluminum | Airfoil Blade Damper

AMCA Class IA Leakage Rated



APPLICATION

The CD50DC is designed for HVAC systems serving data center facilities where high performance and reliability is expected. This model offers the lowest AMCA leakage rating of 3 cfm/ft² @ 1" w.g., which meets the requirements of the International Energy Conservation Code (IECC). CD50DC features extruded aluminum airfoil blades for minimal pressure drop, and a reinforced frame.

STANDARD CONSTRUCTION

Frame	5" x 1" x .125" (127 x 25 x 3.2) 6063-T6 extruded aluminum.
Blades	6" (152) wide, 6063-T6 extruded aluminum airfoil. Opposed blade action is standard, parallel blade action optional.
Blade Seals	Santoprene mechanically fastened.
Jamb Seals	301 stainless steel cambered compression type.
Bearings	Lexan.
Axles	1/2" (13) plated steel hex.
Linkage	Concealed out of airstream.
Operator Shaft	1/2" (13) dia. x 6" long plated steel for single section, or two sections joined with couplers. 1" (25) dia. jackshaft for multi-section assemblies.

PERFORMANCE RATINGS

Leakage	AMCA Class IA (see page 2)
Velocity	Up to 4000 fpm (20.3 m/s)
Pressure	Up to 8 in. w.g. (2.0 kPa)
Temperature	-72°F to +275°F (-58°C to +135°C) with Santoprene blade seals
Torque	Opposed blades: 5 in-lbs/ft ² and Parallel blades: 7 in-lb/ft ²
Airflow	Both directions
R Value	1.16 (tested to ASTM C1363-2011)

OPTIONS & ACCESSORIES

Frame	Front flange, rear or both sides with or without bolt holes.
Operator Shaft	Single-section jackshaft, 1" (25) dia.
Sleeve/Transition	Factory installed, with or without transitions.
Linkage, axles & bearings	Stainless steel.
Blade seals	Silicone -80°F to 450°F (-62°C - 232°C).
Actuators	Factory provided and installed.
Switches	SP100 blade (open/closed) switch package.
Couplers	Used to join 2 damper sections up to 30 sq.ft.
Finish	Clear Anodized.



HIGHLIGHTS

- ▶ Class IA Leakage performance for energy savings
- ▶ Aluminum airfoil blades for low pressure drop
- ▶ Mechanically fastened blade seals for longevity
- ▶ Shake-proof linkage for low maintenance

DIMENSIONS & WEIGHT

Minimum	12" x 12 3/4" (305 x 324)	
Maximum	Section:	60" x 72" (1524 x 1829)
	Assembly:	Unlimited
Weight:	5 lbs./ft ² (2.3 kg)	

Note:
Dimensions shown in parenthesis () indicate millimeters.

PERFORMANCE DATA

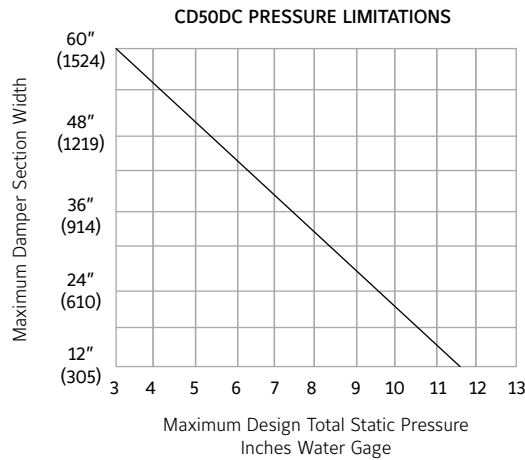

The CD50DC may be used in systems with total pressures exceeding 3.5" by reducing damper section width as indicated. Example: Maximum design total pressure of 8.5" w.g. would require CD50DC damper with maximum section width of 36" (914).

Pressure limitations shown above allow maximum blade deflection of L/180 of span on 60" (1524) damper widths. Deflections in other damper widths (less than 48" [1219]) at higher pressures shown will result in blade deflection substantially less than 1/180 of span.

Leakage Class	Leakage*			
	Required Rating		Extended Ranges (Opt.)	
	1" (0.25 kPa)	4" (1.0 kPa)	8" (2.0 kPa)	12" (3.0 kPa)
1A	3 (15.2)	N/A	N/A	N/A
1	4 (20.3)	8 (40.6)	11 (55.9)	14 (71.1)
2	10 (50.8)	20 (102)	28 (142)	35 (178)
3	40 (203)	80 (406)	112 (569)	140 (711)

Damper Width (Inches)	1 IN. W.G.	4 IN. W.G.	8 IN. W.G.
12" (305)	IA	1	2
24" (610)	IA	1	2
36" (914)	IA	1	N/A
48" (1219)	IA	1	N/A
60" (1524)	IA	1	N/A

Leakage testing conducted in accordance with AMCA Standard 500-D-98. Torque applied holding damper closed, 5 in. lbs./sq.ft. on opposed blade dampers and 7 in. lbs./sq.ft. on parallel blade dampers. Air leakage is based on operation between 50°F to 104°F. All data corrected to represent standard air density 0.075 lbs/ft³.

* Leakage Class Definitions

As defined by AMCA, the maximum allowable leakage is as follows:

Leakage Class 1A (is only defined @ 1" wg)

- 3 cfm/ft² (.92 cmm/m²) @ 1" wg (0.25 kPa)

Leakage Class 1

- 4 cfm/ft² (1.22 cmm/m²) @ 1" wg (0.25 kPa)
- 8 cfm/ft² (2.44 cmm/m²) @ 4" wg (1 kPa)
- 11.3 cfm/ft² (3.45 cmm/m²) @ 8" wg (2 kPa)
- 12.6 cfm/ft² (3.85 cmm/m²) @ 10" wg (2.5 kPa)

PERFORMANCE DATA

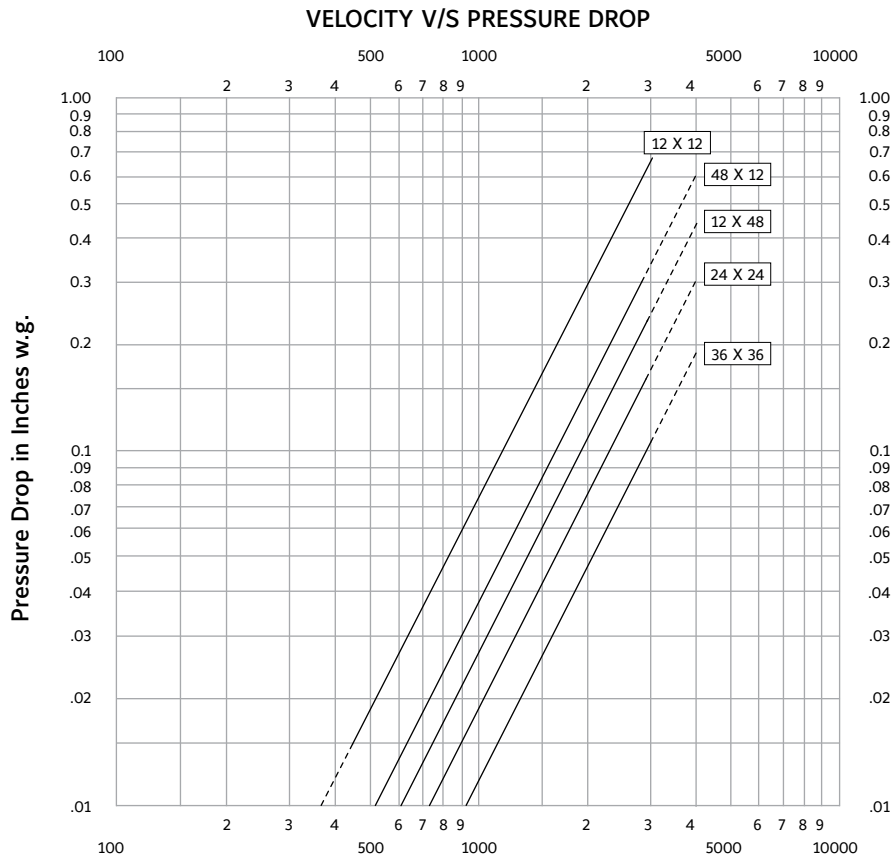

Face Velocity - Feet/Minute AMCA Fig. 5.3

CD50DC sizes 12 x 12, 24 x 24, 48 x 12, 12 x 48, 36 x 36 (305 x 305, 610 x 610, 1219 x 305, 305 x 1219, 914 x 914)

All data corrected to represent standard air at a density of 0.075 lbs/ft³.

SOUND RATINGS

Damper size	Damper Full Open		Damper 75% Open		Damper 50% Open		Damper 25% Open	
	CFM	NC	CFM	NC	CFM	NC	CFM	NC
12 x 12 (305 x 305)	2000	17	1500	11	1000	11	500	*
	3000	28	2250	22	1500	19	750	*
	4000	35	3000	29	2000	24	1000	*
18 x 18 (457 x 457)	2250	17	1688	10	1125	21	563	*
	4500	33	3375	26	2250	32	1125	*
	6750	43	5063	37	3375	40	1688	15
24 x 24 (610 x 610)	4000	11	3000	10	2000	26	1000	*
	8000	32	6000	30	4000	38	2000	21
	12000	43	9000	42	6000	46	3000	31

NC = Noise criteria in Decibels is based on 10db room effect and 10db of room attenuation.

* = Less than 10 NC

See ASHRAE Handbook (1977 Fundamentals, Chapter 7) for explanation of NC Ratings.

DIMENSIONAL INFORMATION

W & H dimensions are furnished with 1/4" (6) deduct standard, unless ordered actual size.

Single section shown with optional 1" (25) dia. jackshaft
Multi-section assemblies are jackshafted standard.

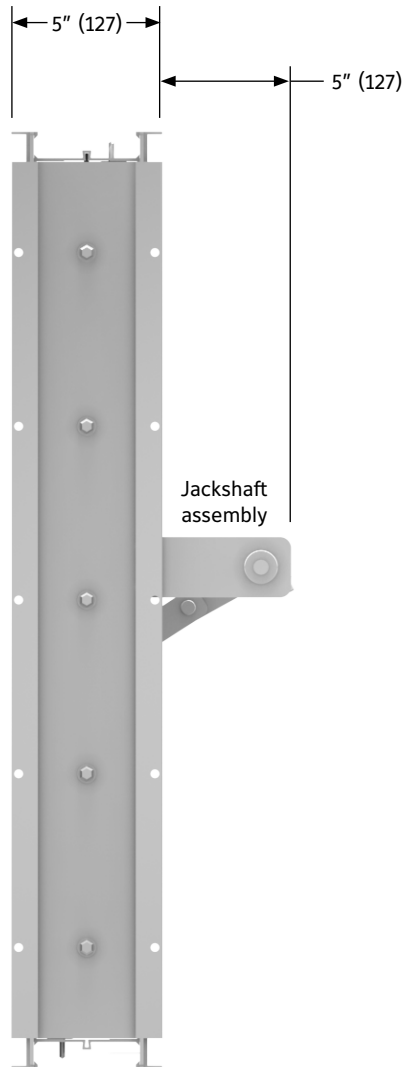

Damper
Side View

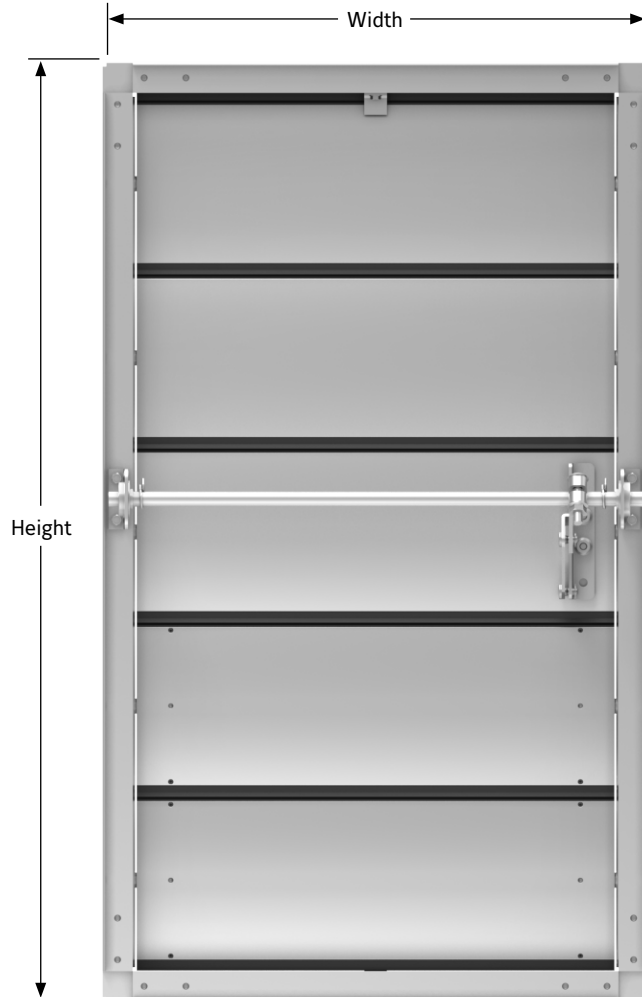

Damper
Face View

CONSTRUCTION & DIMENSIONAL INFORMATION

Channel Frame and Flange Frame Options

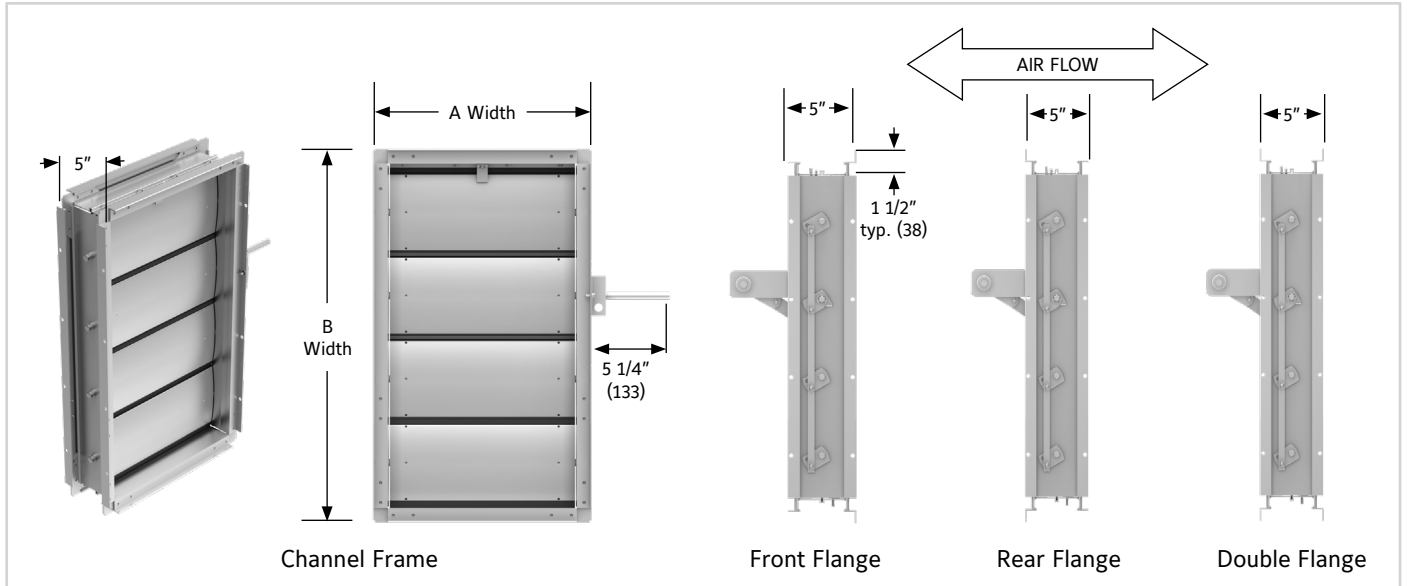

Note: Extended shaft shown installed. Shaft screwed to corner of frame for shipping.

Ruskin CD50DC is rated for airflow in either direction, but Ruskin defines the "front" of the damper as the opposite side of the jackshaft and the "rear" as the jackshaft side. Unless specifically ordered otherwise, when looking at the concealed linkage side of the damper and the bottom blade turns clockwise to open, then the "front" surface is adjacent on the right.

Blade Action and Envelope Dimensions

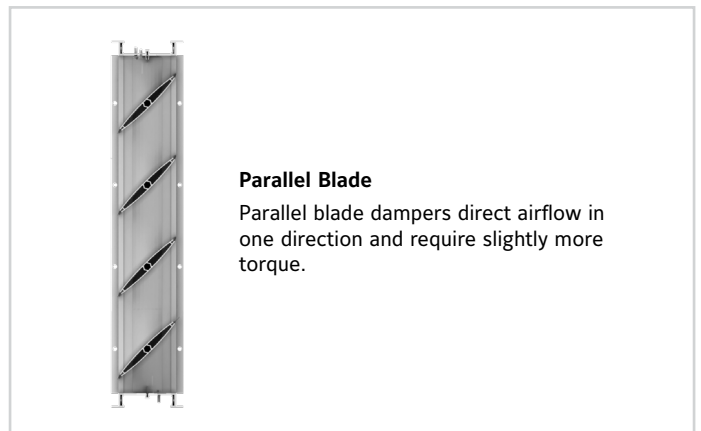
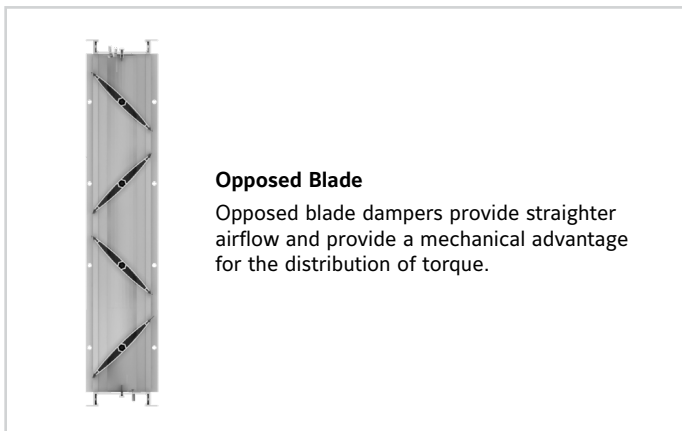

CONSTRUCTION & DIMENSIONAL INFORMATION

Multi-section Dampers

Dampers over the maximum single section size will require multiple damper sections, typically built in equal sizes. Multi-section dampers typically use jackshafts to link sections together.

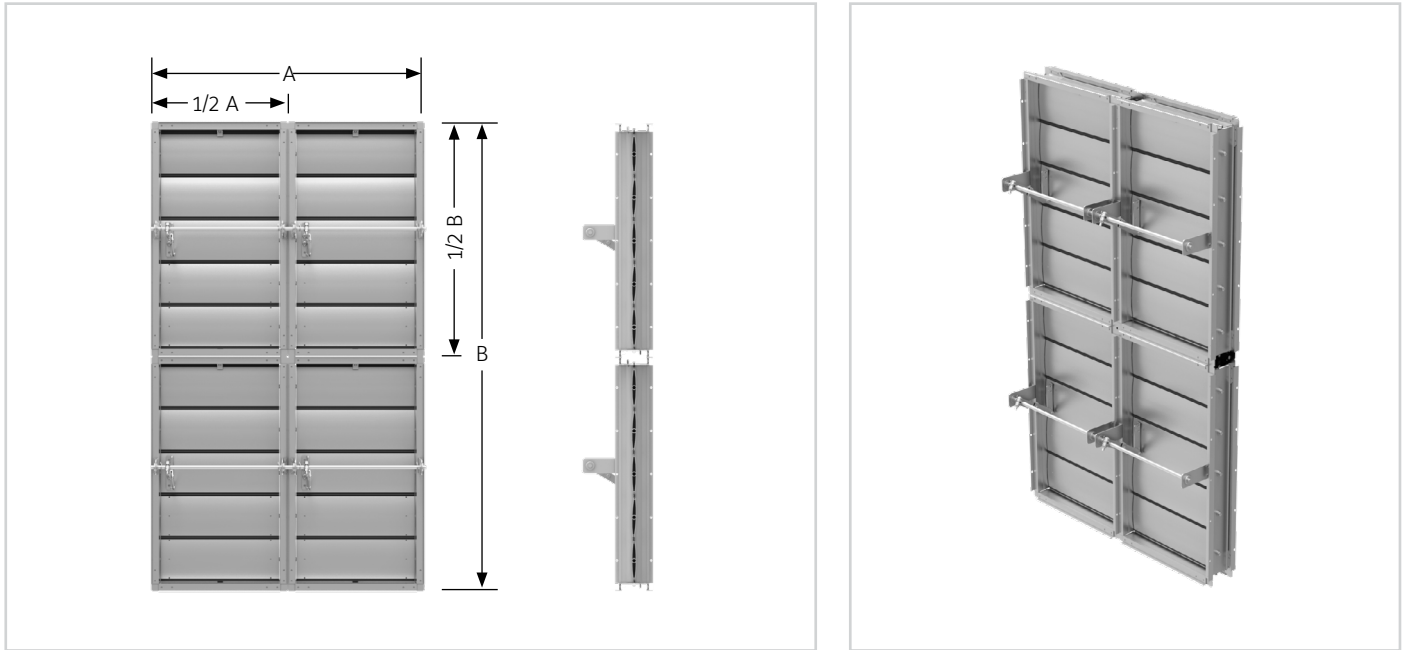

Note: Multiple section dampers are not intended to be structural supports. Additional bracing is recommended to support the damper weight and support against system pressure. Refer to Installation Instructions.

Sleeve Transitions

When a rectangular damper is your only option but you need to connect to a round, oval, or smaller than minimum size duct, you can use a transition to match the field-connection requirement. CR-Style is a round transition, C-Style is a step-down rectangular transition, and CO-Style is an oval transition. CR-Style is ordered by the diameter and C-Style and CO-Style are ordered by the A X B dimension shown below.

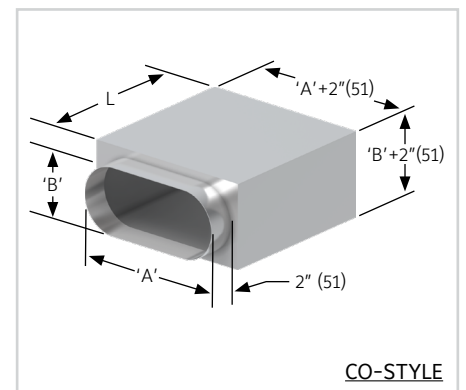
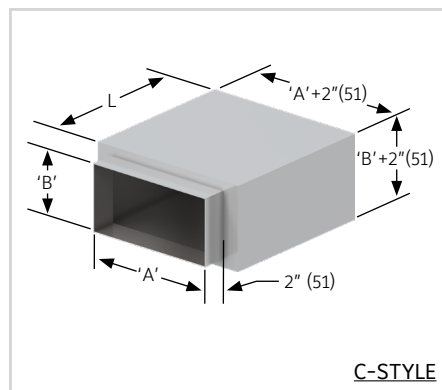
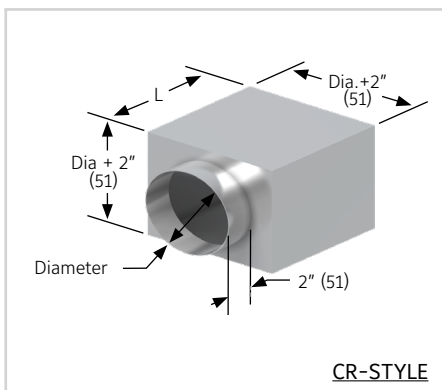

L = Sleeve Length

TYPICAL ACTUATOR MOUNTING DETAILS

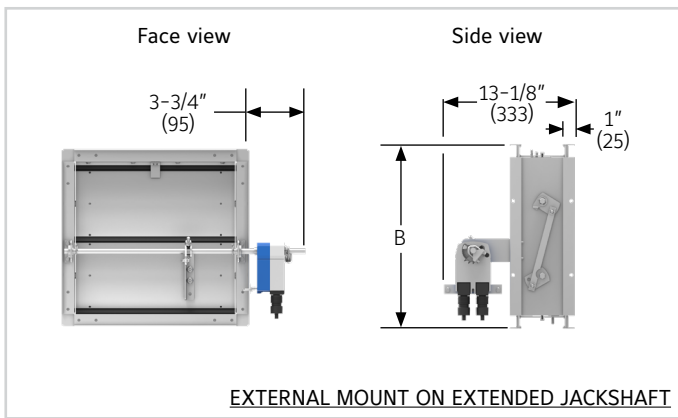
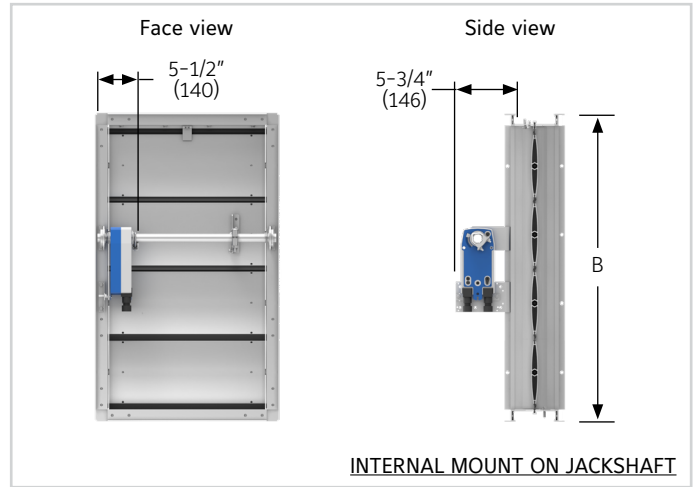
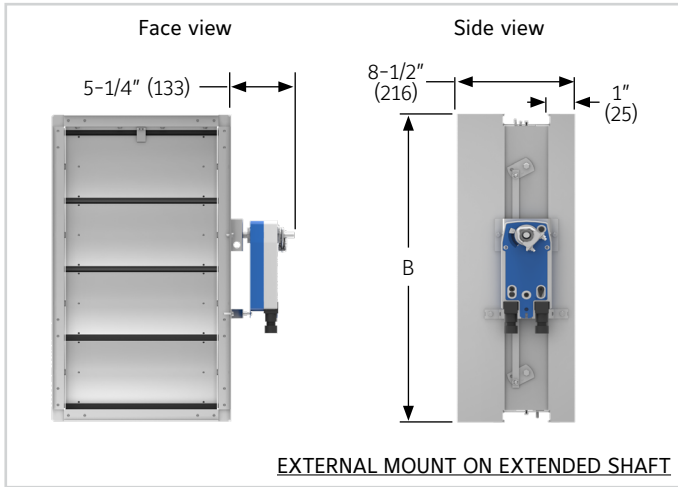

2X1 COUPLER OPTION

2X1 coupler option allows two damper sections to be joined without a jackshaft. This provides the shortest depth when actuator is mounted to side of damper frame, outside the airstream.

Coupler option available for damper sizes up to 30 sq. ft. (Available size ranges: 120" x 36", 96" x 45" & 72" x 60")



SUGGESTED SPECIFICATION

Furnish and install, at locations shown on plans, or in accordance with schedules, Low leakage dampers shall meet the following minimum construction standards: Frames shall be 5" x 1" x .125" (minimum thickness) (127 x 25 x 3.2) 6063-T6 extruded aluminum hat channel with hat mounting flanges on both sides of the frame. Each corner shall be reinforced with two die formed internal braces and machine staked for maximum rigidity. Blades shall be airfoil type extruded aluminum (maximum 6" [152] depth) with integral structural reinforcing tube running full length of each blade.

Blade edge seals shall be extruded double edge design with inflatable pocket which enables air pressure from either direction to assist in blade to blade seal off. Blades seals shall be mechanically locked in extruded blade slots, yet shall be easily replaceable in field. Adhesive or clip-on type blade seals are not acceptable. Bearings shall be non-corrosive molded synthetic. Axles shall be hexagonal (round not acceptable) to provide positive locking connection to blades and linkage. Linkage shall be concealed in frame. Submittal must include leakage, maximum air flow and maximum pressure ratings based on AMCA Publication 500. Damper shall be tested and licensed in accordance with AMCA 511 for Air Performance and Air Leakage. Damper widths from 12" to 60" (305 to 1524) wide shall not leak any greater than 8 cfm sq.ft. @ 4" w.g. and a maximum of 3 CFM sq.ft. @ 1" w.g. Dampers shall be in all respects equivalent to Ruskin Model CD50DC.



LINKS TO IMPORTANT DOCUMENTS

Document Title
O & M for Commercial Control Dampers
Standard Multi-Section Details
T-Flange Frame Option
Face Bypass Mixing Damper
Flange Frame Options
Minimum Torque Requirements for Standard Commercial Control Dampers
Basic Installation Sheet
SP100 and SP100FK Switch Package

Document Title
Replacement Parts Catalog
Limited Warranty Document



Plot 22 & 23, Block-4,
Modern Ind.Area
Umm Al Quwain, UAE
Phone: (971) 6-5620320