

CD60DC (DATA CENTER)

High-performance Galvanized Steel Airfoil Blade Damper
AMCA Class IA Leakage Rated



APPLICATION

The CD60DC is designed for HVAC systems serving data center facilities where high performance and reliability is expected. This model offers the lowest AMCA leakage rating of 3 cfm/ft² @ 1" w.g. which meets the requirements of the International Energy Conservation Code (IECC). CD60DC features one-piece roll formed airfoil blades for minimal pressure drop, and a robust uniframe design.

STANDARD CONSTRUCTION

Frame	5" x 1" x 16 ga. (127 x 25 x 1.6) galvanized steel channel.
Blades	Galvanized steel, one piece airfoil shaped, construction of 14 gauge (2.0) equivalent strength, typically 6" (152) wide, maximum 8 5/8" wide. Opposed blade action standard, parallel blade action optional.
Blade Seals	Santoprene blade edge seals mechanically fastened.
Jamb Seals	300 Series stainless steel cambered compression type.
Bearings	Oil impregnated, permanently lubricated, stainless steel sleeve.
Axles	1/2" (13) plated steel hex.
Linkage	Plated steel, concealed out of airstream.
Operator Shaft	1/2" (13) dia. x 6" long plated steel for single section and coupler option. 1" (25) dia. jackshaft for multi-section assemblies.



PERFORMANCE RATINGS

Leakage	AMCA Class IA (see page 2)
Velocity	Up to 6000 fpm (30.5 m/s)
Pressure	Up to 13 in. w.g. (3.25 kPa)
Temperature	-72°F to +275°F (-58°C to +135°C)
Torque	OB: 5 in-lb/ft ² and PB: 7 in-lb/ft ²
Airflow	Both directions

OPTIONS & ACCESSORIES

Frame	Front flange, rear or both sides with or without bolt holes.
Operator Shaft	Single-section jackshaft, 1" (25) dia.
Sleeve/Transition	Factory installed, with or without transitions.
Actuators	Factory provided and installed.
Manual Operator	Locking hand quadrant.
Switches	SP100 - blade (open/closed) position indicator.
Couplers	Used to join 2 damper sections up to 30 sq.ft.
Linkage & Axles	Stainless steel.
Blade Seals	Silicone -80°F to 450°F (-62°C - 232°C).

FEATURES

- ▶ Class IA leakage performance saves energy
- ▶ One-piece airfoil blade for low pressure drop
- ▶ Blade seals mechanically fastened for longevity
- ▶ Shake-proof linkage for low maintenance

DIMENSIONS & WEIGHT

Minimum	12" x 12 3/4" (305 x 324)	
Maximum	Section:	60" x 72" (1524 x 1829)
	Assembly:	Unlimited
Weight:	7 lbs./ft ² (3.2 kg)	

Note:
Values shown in parenthesis () indicate millimeters.

PERFORMANCE DATA

Pressure Drop Data CD60DC air performance testing is performed in accordance with AMCA Standard 500-D configuration 5.3 as illustrated below. All data are corrected to standard air density of .075 lb/ft³ (1.201 kg/m³).

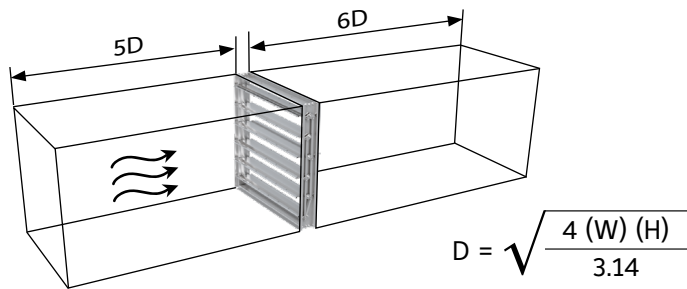

Ruskin Titus Gulf certifies that model CD60DC shown herein is licensed to bear the AMCA seal. The AMCA certified ratings seal applies to air leakage and air performance ratings. The ratings shown are based on tests and procedures performed in accordance with AMCA Publication 511 and comply with the requirements of the AMCA certified ratings program.

AMCA Figure 5.3 was established to represent a fully ducted damper with straight duct upstream and downstream. With entrance and exit losses minimized by this straight duct arrangement, this configuration has the lowest pressure drop of all three configurations.

Air Performance Data—AMCA Test Figure 5.3									
12" x 12" (305 x 305)		24" x 24" (610 x 610)		36" x 36" (914 x 914)		12" x 48" (305 x 1219)		48" x 12" (1219 x 305)	
Velocity	Pressure Drop	Velocity	Pressure Drop	Velocity	Pressure Drop	Velocity	Pressure Drop	Velocity	Pressure Drop
FPM	in. WG	FPM	in. WG	FPM	in. WG	FPM	in. WG	FPM	in. WG
499	0.02	506	0.005	517	0.005	508	0.005	509	0.01
869	0.06	998	0.03	1007	0.02	1002	0.03	1005	0.04
1417	0.17	1514	0.06	1404	0.03	1519	0.06	1523	0.08
1980	0.34	2012	0.11	1949	0.05	2019	0.10	2024	0.16
2986	0.79	2867	0.22	3004	0.12	2883	0.21	2884	0.32

Leakage Data Air Leakage testing is performed in accordance with ANSI/AMCA Standard 500-D, figure 5.5. Data are based on a torque of 7 in-lbs/ft² (.56 N.m./m²) applied to close and seat the damper during the test. Air Leakage is based on operation between 32°F - 120°F (0°C - 49°C).

CD60DC	LEAKAGE CLASS*			
	1" w.g. (0.25 kPa)	4" w.g. (1 kPa)	8" w.g. (2 kPa)	10" w.g. (2.5 kPa)
Maximum Damper Width				
60" (1524)	1A	1	N/A	N/A

*Leakage Class Definitions

As defined by AMCA, the maximum allowable leakage is as follows:

Leakage Class 1A (is only defined @ 1" wg)

- ▶ 3 cfm/ft² (.92 cmm/m²) @ 1" wg (0.25 kPa) Leakage Class 1
- ▶ 4 cfm/ft² (1.22 cmm/m²) @ 1" wg (0.25 kPa)
- ▶ 8 cfm/ft² (2.44 cmm/m²) @ 4" wg (1 kPa)
- ▶ 11.3 cfm/ft² (3.45 cmm/m²) @ 8" wg (2 kPa)
- ▶ 12.6 cfm/ft² (3.85 cmm/m²) @ 10" wg (2.5 kPa)

Maximum System Velocity And Pressure The CD60DC may be used in systems with higher velocities and pressures by reducing damper section width as indicated below:

VELOCITY AND PRESSURE DATA		
Damper Width Inches	Maximum System Pressure In. wg (kPa)	Maximum System Velocity FPM (m/s)
60" (1524)	3.5" (0.9)	3000 (15.2)
48" (1219)	6.2" (1.5)	4000 (20.3)
36" (914)	8.5" (2.1)	4000 (20.3)
24" (610)	10.8" (2.7)	5000 (25.4)
12" (305)	13.0" (3.25)	6000 (30.5)

DIMENSIONAL INFORMATION

W & H dimensions are furnished with 1/4" (6) deduct standard, unless ordered actual size.

Single section shown with optional 1" (25) dia. jackshaft
Multi-section assemblies are jackshafted standard.

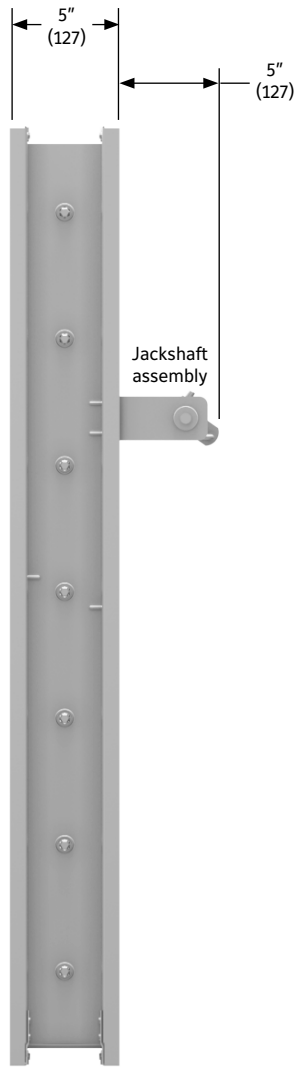

Damper
Side View



Damper
Face View

CONSTRUCTION & DIMENSIONAL INFORMATION

Channel Frame and Flange Frame Options

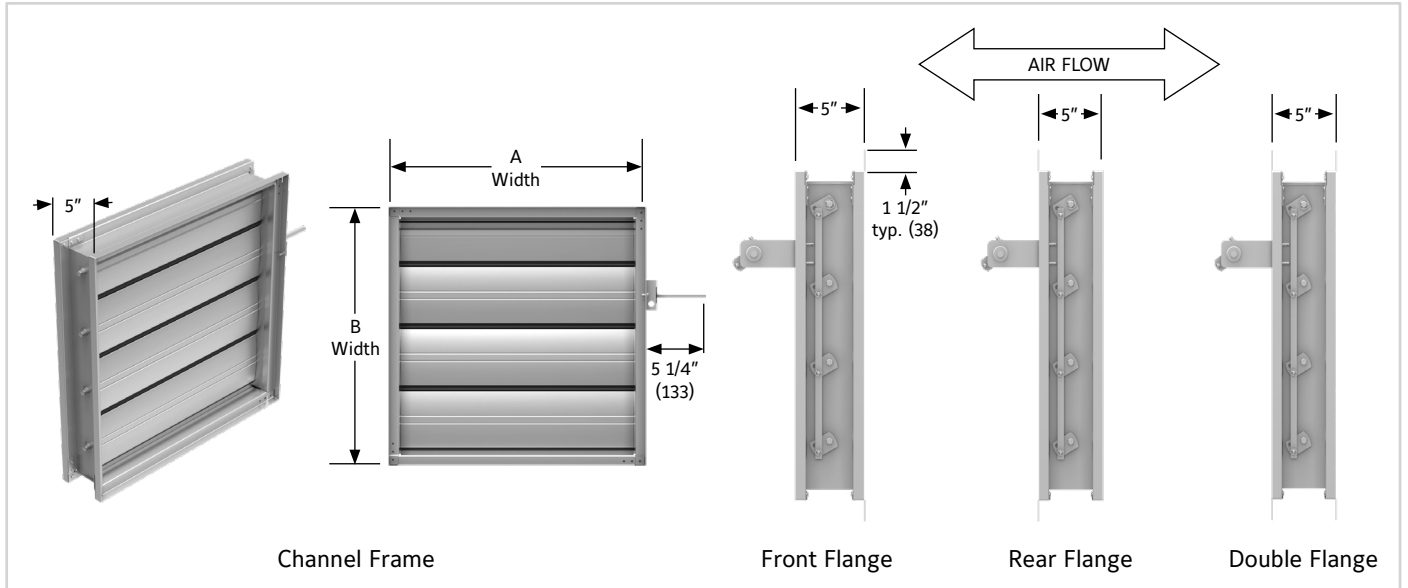

Note: Extended shaft shown installed. Shaft screwed to corner of frame for shipping.

Ruskin CD60DC is rated for airflow in either direction, but Ruskin defines the "front" of the damper as the opposite side of the jackshaft and the "rear" as the jackshaft side. Unless specifically ordered otherwise, when looking at the concealed linkage side of the damper and the bottom blade turns clockwise to open, then the "front" surface is adjacent on the right.

Blade Action and Envelope Dimensions

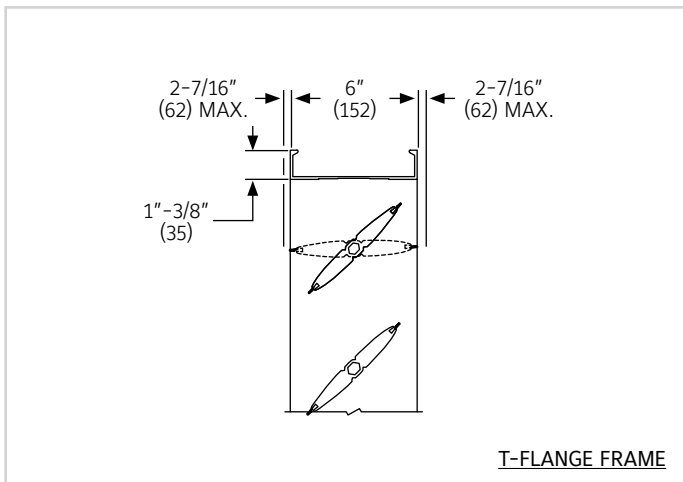
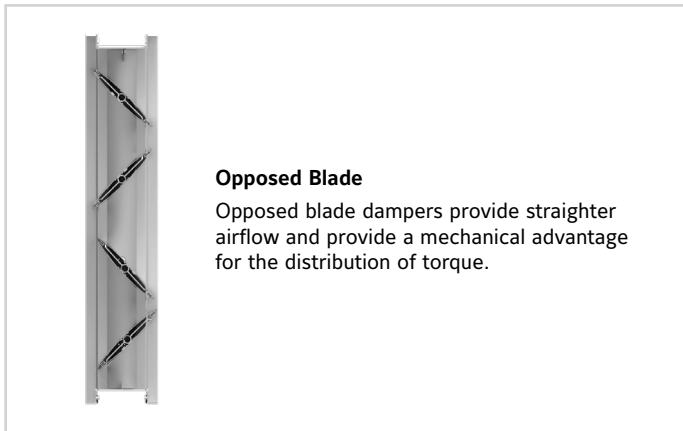

CONSTRUCTION & DIMENSIONAL INFORMATION

Multi-section Dampers

Dampers over the maximum single section size will require multiple damper sections, typically built in equal sizes. Multi-section dampers typically use jackshafts to link sections together.

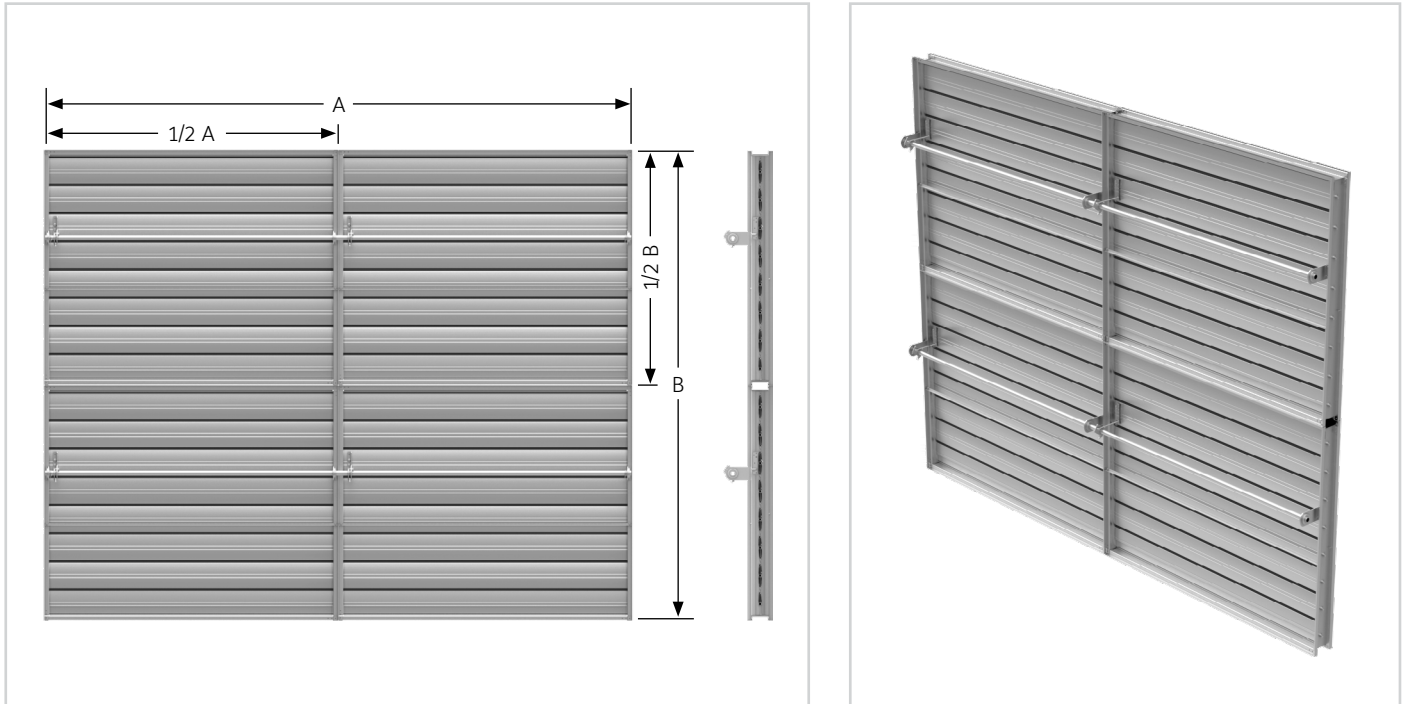

Note: Multiple section dampers are not intended to be structural supports. Additional bracing is recommended to support the damper weight and support against system pressure. Refer to Installation Instructions.

Sleeve Transitions

When a rectangular damper is your only option but you need to connect to a round, oval, or smaller than minimum size duct, you can use a transition to match the field-connection requirement. CR-Style is a round transition, C-Style is a step-down rectangular transition, and CO-Style is an oval transition. CR-Style is ordered by the diameter and C-Style and CO-Style are ordered by the A X B dimension shown below.

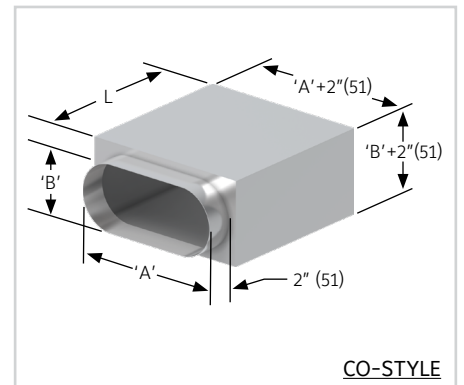
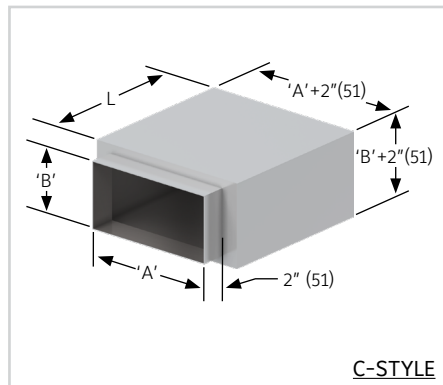
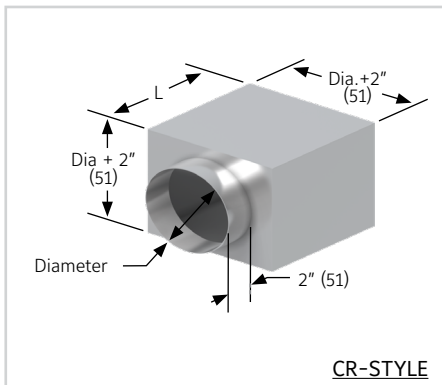

L = Sleeve Length

TYPICAL ACTUATOR MOUNTING DETAILS

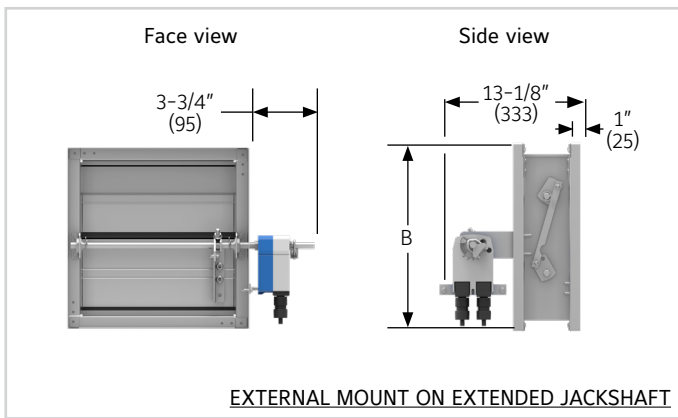
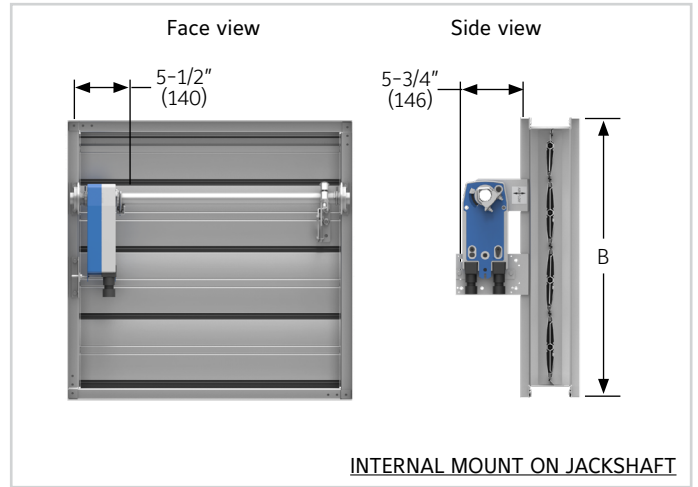
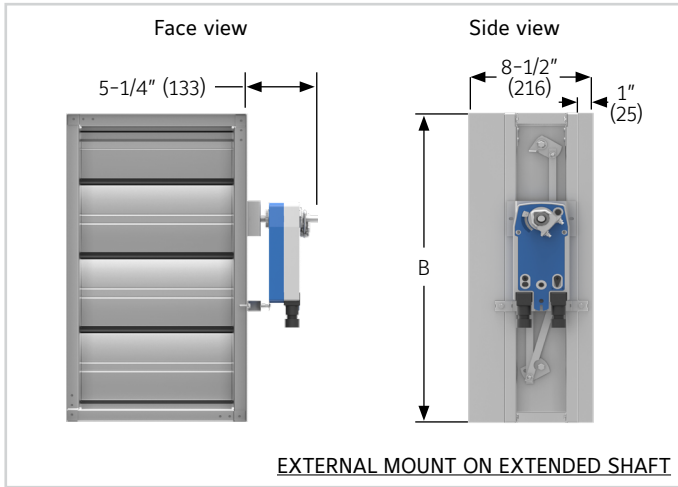

2X1 COUPLER OPTION

2X1 coupler option allows two damper sections to be joined without a jackshaft. This provides the shortest depth when actuator is mounted to side of damper frame, outside the airstream.

Coupler option available for damper sizes up to 30 sq. ft. (Available size ranges: 120" x 36", 96" x 45" & 72" x 60")



SUGGESTED SPECIFICATION

Furnish and install, at locations shown on plans, low leakage airfoil control dampers meeting the following minimum construction standards. Control dampers shall be produced in an ISO9001 certified factory. Frame shall be one-piece uniframe construction of 16 ga. (1.6) galvanized steel roll formed hat channel structurally equivalent to a minimum 13 ga. (2.4) frame. Blades shall be 14 ga. (2.0) equivalent galvanized steel, rollformed airfoil type for low pressure drop and low noise generation. Blade edge seals shall be Santoprene TPV type or equivalent mechanically locked into the blade edge. Adhesive or clip-on type seals are unacceptable. Jamb seals shall be stainless steel chambered compression type to prevent leakage between blade end and damper frame. Blade end overlapping frame is unacceptable. Multiple section dampers must have factory installed jackshafts unless clearly eliminated by engineer. Bearings shall be 304 stainless steel, oil impregnated, and self-lubricating sleeve type with a 450 pound (204 kg) minimum radial crush load. Bearings shall turn in extruded holes in the damper frame. Axles shall be hexagonal positively locked into the damper blade. Linkage shall be concealed out of airstream, within the damper frame to reduce pressure drop and noise. Temperature limits shall be -72°(-58°C) to +275°F (+135°C). Submittal must include leakage, maximum air flow and maximum pressure ratings based on AMCA Publication 500. Damper shall be tested and licensed in accordance with AMCA 511 for Air Performance and Air Leakage. Damper widths from 12" to 60" (305 to 1524) wide shall not leak any greater than 3 cfm/sq.ft. at 1" w.g. (15.2 l/s-m² at .25 kPa). Dampers shall be equivalent in all respects to Ruskin Model CD60DC.

LINKS TO IMPORTANT DOCUMENTS

Document Title	Document Title
O & M for Commercial Control Dampers	SP100 and SP100FK Switch Package
Standard Multi-Section Details	Replacement Parts Catalog
T-Flange Frame Option	Limited Warranty Document
Face Bypass Mixing Damper	Single Section Control Damper Installation
Flange Frame Options	
Minimum Torque Requirements for Standard Commercial Control Dampers	
Basic Installation Sheet	
Crank Arms, Extended Shaft and Hand Quad	



Plot 22 & 23, Block-4,
Modern Ind.Area
Umm Al Quwain, UAE
Phone: (971) 6-5620320