

May 2009

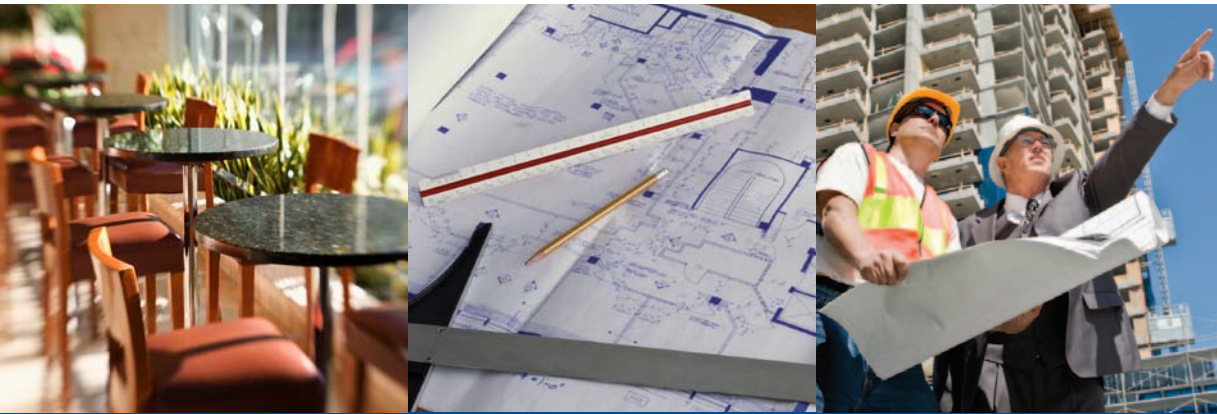

Fantech



POWER ROOF VENTILATORS, WALL FANS & AIR CIRCULATORS

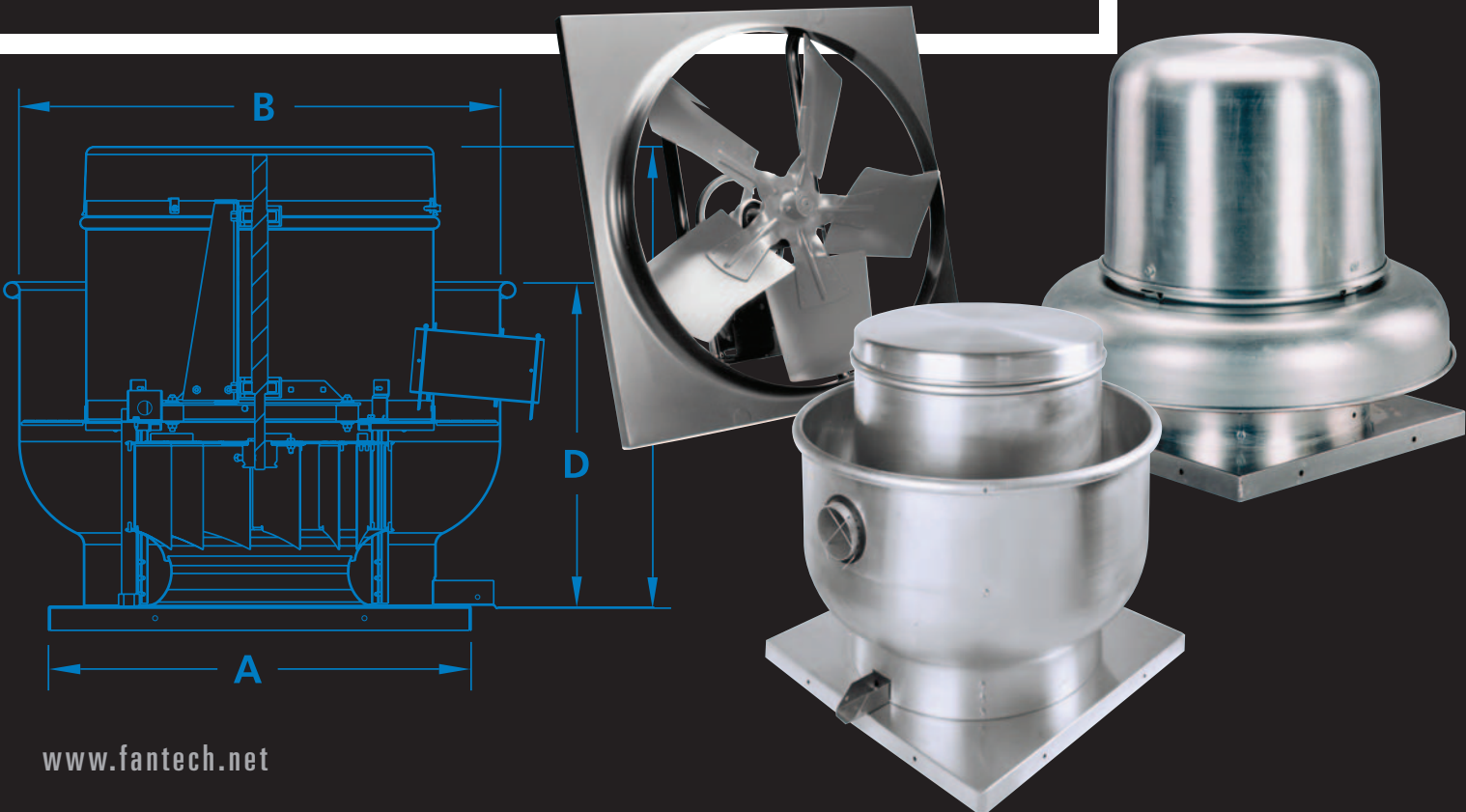

www.fantech.net

IMPROVING INDOOR AIR QUALITY THROUGH BETTER VENTILATION

Power Roof Ventilators, Wall Fans, Air Circulators Index

Centrifugal Downblast Ventilators	4
Direct-Drive Downblast (DDD)	4
Belt-Drive Downblast (BDD)	8
Centrifugal Upblast Ventilators	26
Direct-Drive Upblast (DDU)	26
Direct-Drive Wall (DDW)	28
Belt-Drive Upblast (BDU)	32
Filtered Supply Ventilators	48
Filtered Supply (FSU)	48
Axial Ventilators	52
Axial Direct-Drive Exhaust (ADE)	52
Axial Direct-Drive Supply (ADS)	54
Axial Belt-Drive Exhaust (ABE)	56
Roof Hood Exhaust (RHE)	58
Roof Hood Supply (RHS)	60
Belt Drive Low Temperature Upblast (BLT)	62
Roof Hood Reversible (RHR)	64
Power Roof Ventilator Accessories	65
Ceiling Exhaust Ventilators	69
Ceiling/Wall Fans 50 CFM (CEV)	70
Ceiling/Wall Fans 80 CFM (CEV)	71
Ceiling and Inline Mount Exhaust Fans 100 to 300 CFM (CEV and IEV)	72
Ceiling and Inline Mount Exhaust Fans 400 to 700 CFM (CEV and IEV)	74
Ceiling and Inline Mount Exhaust Fans 900 to 1500 CFM (CEV and IEV)	76
Inline Mount Exhaust Fans 2000 to 3500 CFM (IEV)	78
Air Flow Charts	79
Ceiling Exhaust Accessories	80
Direct Drive Propeller Fans	82
Shutter Mounted Exhaust (SHE)	82
Corrosion Resistant Shutters (SCR)	83
Guard Mounted Exhaust (GMS)	84
Medium Duty Exhaust (VLD)	85
Heavy Duty Exhaust (VHD)	85
Stamped Aluminum Blade Venturi Exhaust (STV)	86

Cast Aluminum Blade Venturi Exhaust (CAV)	87
Hazardous Location Exhaust (CAV)	88
Hazardous Location Ring (HLE)	89
Flanged Ring Fan (FRF)	90
Reversible Exhaust and Supply (DRV)	90
Belt Drive Propeller Fans	91
Standard Duty 36" Reversible (SDR)	91
Standard Duty Exhaust (SDE)	92
Standard Duty Supply (SDS)	94
Wall Mount Cabinet Exhaust (WMC)	96
Wall Mount Cabinet Supply (WMS)	98
Medium Duty Exhaust (MDE)	100
Heavy Duty Exhaust (HDE)	102
Wall Fan Accessories	104
Intake Louvers (FLV/MLV)	107
Gravity-Relief/Intake Ventilators (TEV/TIV)	109
Air Circulators	114
Industrial (IND)	115
Special Voltages (SPC)	116
Mobile Direct-Drive (DDM)	117
Mobile Belt-Drive (BDM)	117
High Volume, High Velocity (HV2)	118
Washdown (SPC)	120
Harzardous Location (SPC)	120
Yellow Air Circulators (YLW)	121
Air Circulator Accessories	122
Air Velocity Profiles	123
Blowers	128
Carpet Blower (BLR)	128
Furnace Blower (BLR)	129
Specialty	130
Whole House (WHS)	130
Transformer Cooling (TCF)	131
Agricultural Fans	132

Centrifugal Ventilators

Direct-Drive Downblast Centrifugal Roof & Wall Ventilators

Direct-drive downblast ventilators are designed for use where steady exhaust ventilation is needed under low to moderate static pressure conditions.

Agency Listing

- All ventilators are UL Standard 705 listed
- Ventilators are CSA listed according to Standard C22.2 No. 113-M1984 (Fans & Ventilators)

Features and Specifications

- Downblast discharge design exhausts foul air from industrial and commercial buildings
- Ventilators can be mounted on the roof or wall
- Durable spun aluminum construction with steel support braces
- Backward inclined aluminum fan wheel
- Externally cooled motor compartment
- Motor located out of discharge airstream
- Motors are 115V or 115/230V, 60 Hz, ball bearing motors with Class B insulation
- PSC motors included in standard design (shaded pole motor style used for B" models)

- One-piece removable exhaust hood
- Inlet temperatures up to 170°F
- Built-in bird screen to protect discharge and ensure safe, obstruction-free operation
- Motor and wheel are easily detachable without removing ventilator from curb
- Junction box mounted in motor compartment
- Windband rolled bead for added strength and easy maneuverability
- Welded curb cap corners eliminate water entry into ducts or building
- All units are speed controllable

Accessories (available separately)

- For more information, see Power Roof Ventilator Accessories
- Speed controllers
- Backdraft dampers
- NEMA 1, NEMA 3R and NEMA 4 disconnect switches
- Fixed mounting curbs

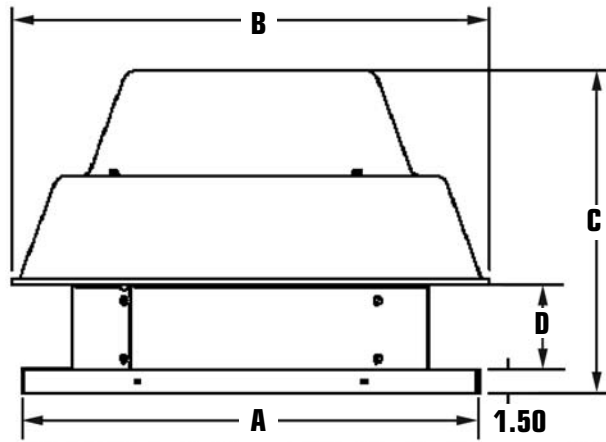

Fantech, Inc. and Systemair Mfg. Inc. certify that the Direct-Drive Downblast Centrifugal Roof & Wall Ventilators shown herein are licensed to bear the AMCA Seal. The ratings shown are based on tests and procedures performed in accordance with AMCA Publication 211 and AMCA Publication 311 and comply with the requirements of the AMCA Certified Ratings Program.

Model No.	Wheel Diameter (In.)	Wheel Bore Size (In.)	Dimensions (In.)				Gauge Thickness (In.)			Total Ship Wt. (lbs.)	Recommended Roof Opening (In.)	Optional Accessories			
			A	B	C	D	Baffle	Venturi	Dome			Roof Mount Backdraft Damper Model No.	8" Ht. Model No.	12" Ht. Model No.	Speed Control (115V Only) Model No.
5DDD084A	8	5/16	19	18-7/8	13-1/4	3-1/2	0.05	0.05	0.063	35	14-1/2 x 14-1/2	5ACC12RD	5ACC17FS	5ACC17FT	5ACC03SC
5DDD085A	8	5/16	19	18-7/8	13-1/4	3-1/2	0.05	0.05	0.063	35	14-1/2 x 14-1/2	5ACC12RD	5ACC17FS	5ACC17FT	5ACC03SC
5DDD106A	10-1/2	1/2	19	22-3/8	16-1/2	3-3/8	0.05	0.05	0.063	45	14-1/2 x 14-1/2	5ACC12RD	5ACC17FS	5ACC17FT	5ACC03SC
5DDD10AA	10-1/2	1/2	19	22-3/8	16-1/2	3-3/8	0.05	0.05	0.063	45	14-1/2 x 14-1/2	5ACC12RD	5ACC17FS	5ACC17FT	5ACC03SC
5DDD128A	12-1/4	1/2	22	24-1/4	17-1/8	4	0.063	0.08	0.08	45	17-1/2 x 17-1/2	5ACC15RD	5ACC20FS	5ACC20FT	5ACC03SC
5DDD12CA	12-1/4	1/2	22	24-1/4	17-1/8	4	0.063	0.08	0.08	45	17-1/2 x 17-1/2	5ACC15RD	5ACC20FS	5ACC20FT	5ACC06SC
5DDD138A	13-1/2	5/8	22	25-5/8	18-1/8	4-3/8	0.063	0.08	0.08	50	17-1/2 x 17-1/2	5ACC15RD	5ACC20FS	5ACC20FT	5ACC03SC
5DDD13DB	13-1/2	5/8	22	25-5/8	18-1/8	4-3/8	0.063	0.08	0.08	50	17-1/2 x 17-1/2	5ACC15RD	5ACC20FS	5ACC20FT	5ACC10SC
5DDD15AA	15	5/8	26	27-7/8	18-1/2	4-3/8	0.063	0.08	0.08	66	21-1/2 x 21-1/2	5ACC19RD	5ACC24FS	5ACC24FT	5ACC03SC
5DDD15CA	15	5/8	26	27-7/8	18-1/2	4-3/8	0.063	0.08	0.08	66	21-1/2 x 21-1/2	5ACC19RD	5ACC24FS	5ACC24FT	5ACC06SC
5DDD16BA	16-1/2	5/8	26	29-3/4	20-1/4	4-3/4	0.063	0.08	0.08	70	21-1/2 x 21-1/2	5ACC19RD	5ACC24FS	5ACC24FT	5ACC06SC
5DDD16DB	16-1/2	5/8	26	29-3/4	20-1/4	4-3/4	0.063	0.08	0.08	70	21-1/2 x 21-1/2	5ACC19RD	5ACC24FS	5ACC24FT	5ACC10SC
5DDD18CA	18-1/4	5/8	30	31-5/8	21-3/8	5-5/8	0.063	0.08	0.08	86	25-1/2 x 25-1/2	5ACC23RD	5ACC28FS	5ACC28FT	5ACC06SC
5DDD18EB	18-1/4	5/8	30	31-5/8	21-3/8	5-5/8	0.063	0.08	0.08	86	25-1/2 x 25-1/2	5ACC23RD	5ACC28FS	5ACC28FT	5ACC10SC

Centrifugal Ventilators

Direct-Drive Downblast Centrifugal Roof & Wall Ventilators

Model Number	HP	RPM	TS (FPM)	0.0" SP		0.125" SP		0.250" SP		0.375" SP		0.500" SP		0.625" SP		.750" SP		.875" SP		1.00" SP		1.25" SP			
				Volts		CFM		CFM		CFM		CFM		CFM		CFM		CFM		CFM		CFM		CFM	
				FLA	Sones†	BHP	Sones†	BHP	Sones†	BHP	Sones†	BHP	Sones†	BHP	Sones†	BHP	Sones†	BHP	Sones†	BHP	Sones†	BHP	Sones†	BHP	Sones†
5DD084A	1/100	1263	3435	115		370		212		87															
				1.5	1.5	5.8	—	3.3	—	2.6	—														
5DD085A	1/25	1661	3456	115		414		345		259		157													
				1.7	2.3	6.8	—	6.0	—	5.9	—	5.4	—												
5DD106A	1/20	1150	3023	115		645		484		309															
				1.7	4.0	5.5	—	5.5	—	5.0	—														
5DD10AA	1/6	1720	4728	115		985		911		824		724		619		498		352							
				1.8		9.6	—	9.4	—	9.1	—	8.1	—	7.9	—	7.8	—	—	—						
5DD128A	1/12	880	2822	115		902		789		658		297													
				6.2/3.1		5.4	0.06	5.0	0.06	4.6	0.07	5.0	0.05												
5DD12CA	1/3	1694	5519	115		1743		1670		1605		1543		1475		1392		1316		1232		1137		889	
				2.4	4.4	15.6	0.35	15.3	0.35	14.9	0.36	14.6	0.36	14.2	0.37	13.8	0.38	13.6	0.39	13.4	0.39	13.2	0.39	13.1	0.38
5DD138A	1/12	869	3071	115		1257		1135		977		711													
				3.6		7.8	0.07	6.4	0.08	5.5	0.09	5.5	0.08												
5DD13DB	1/2	1684	5952	115/230		2226		2164		2102		2040		1970		1897		1813		1740		1657		1469	
				6.2/3.1		18.2	0.44	17.5	0.47	17.1	0.48	15.6	0.49	14.2	0.51	13.4	0.54	12.7	0.56	11.4	0.57	12.2	0.56	13.9	0.56
5DD15AA	1/6	866	3401	115		1716		1563		1384		1166		664											
				4.4		7.5	0.14	7.1	0.15	6.8	0.16	6.1	0.16	5.6	0.13										
5DD15CA	1/3	1124	4496	115		2160		2045		1930		1792		1645		1481		1255		767					
				8.4/4.2		11.9	0.32	11.5	0.33	11.1	0.34	10.3	0.34	9.7	0.34	9.1	0.34	9.0	0.34	9.0	0.28				
5DD16BA	1/4	868	3749	115		2337		2191		2038		1835		1573		599									
						11.0	0.24	9.6	0.25	8.9	0.25	6.7	0.26	6.5	0.26	6.8	0.24								
5DD16DB	1/2	1143	4937	115/230		2914		2787		2660		2526		2389		2231		2061		1848		1493			
						15.9	0.45	14.7	0.46	14.2	0.48	13.4	0.49	11.7	0.50	10.3	0.50	10.3	0.50	10.1	0.50	11.0	0.49		
5DD18CA	1/3	856	4090	115		3120		2948		2767		2556		2270		1865		896							
						15.1	0.34	13.3	0.36	11.3	0.36	8.6	0.36	6.4	0.36	7.4	0.36	8.5	0.26						
5DD18EB	3/4	1106	5284	115/230		4037		3902		3766		3629		3476		3324		3147		2970		2765		1407	
						19.8	0.75	19.5	0.77	19.2	0.80	18.8	0.82	18.4	0.85	18.0	0.87	17.8	0.89	17.7	0.89	17.5	0.89	18.5	0.57

Performance certified is for installation type A: free inlet, free outlet. Performance rating includes the effects of bird screen. Speed (RPM) shown is nominal, and performance is based on actual speed of test.

† The sound ratings shown are loudness values in fan sones at 5 ft. (1.5m) in a hemispherical free field calculated per AMCA standard 301. Values shown are for installation type A, free inlet hemispherical sone levels.

Typical Specifications:

Direct-Drive Downblast Roof & Wall Exhaust Fans

Roof & wall mount exhaust fans shall be centrifugal downblast direct-drive type. The fan wheel shall be centrifugal backward inclined, blades and wheel cone to be constructed of aluminum and shall include a wheel cone matched to the inlet cone for precise running tolerances. Wheels shall be statically and dynamically balanced. The fan housing shall be constructed of heavy gauge aluminum with a rigid steel support structure. Baffles and motor compartment hoods shall have a rolled bead for added strength. Motors shall be mounted out of the airstream. Fresh air for motor cooling shall be drawn into the motor compartment from an area free of discharge contaminants. Motors shall be readily accessible for maintenance. A junction box shall be factory installed to permit a disconnect switch to be wired to the fan motor within the motor compartment. A conduit chase shall be provided through the curb cap to the motor compartment for ease of electrical wiring. All fans shall bear the AMCA Certified Ratings Seal for sound and air performance. Each fan shall bear a permanently affixed manufacturer's nameplate containing model number and carry a one-year warranty. Fans shall be Fantech Model Direct-Drive Downblast Centrifugal Roof & Wall Ventilators as manufactured by Systemair Mfg. Inc., Lenexa, Kansas.

Centrifugal Ventilators

Direct-Drive Downblast Centrifugal Roof & Wall Ventilators – Octave Sound Data

The sound power ratings shown are in decibels, referred to 10^{-12} Watts calculated per AMCA Standard 301. Values shown are for inlet L_{w_i} A sound power levels for installation Type A: free inlet, free outlet. Ratings do not include the effects of duct end correction. For models shown on this page, the AMCA Certified Ratings Seal applies to air performance and some values only.

Model 5DDD084A; Wheel Dia. 8" Sound Data											
HP	RPM	SP	63 Hz	125 Hz	250 Hz	500 Hz	1000 Hz	2000 Hz	4000 Hz	8000 Hz	L_{w_i} A
1/100	1263	0	65	67	72	62	54	52	49	43	66
		0.13	69	66	71	61	54	52	49	42	65
		0.25	67	67	70	60	53	50	48	41	64

Model 5DDD085A; Wheel Dia. 8" Sound Data											
HP	RPM	SP	63 Hz	125 Hz	250 Hz	500 Hz	1000 Hz	2000 Hz	4000 Hz	8000 Hz	L_{w_i} A
1/25	1650	0	62	66	71	63	63	55	54	45	67
		0.13	62	65	71	62	58	53	51	43	65
		0.25	63	65	72	60	55	52	48	41	65

Model 5DDD106A; Wheel Dia. 10-1/2" Sound Data											
HP	RPM	SP	63 Hz	125 Hz	250 Hz	500 Hz	1000 Hz	2000 Hz	4000 Hz	8000 Hz	L_{w_i} A
1/12	1150	0	63	68	68	57	54	52	48	37	63
		0.13	66	68	67	55	51	48	45	36	61
		0.25	66	67	65	52	50	47	43	35	59
		0.38	73	68	65	51	50	46	42	34	59

Model 5DDD10AA; Wheel Dia. 10-1/2" Sound Data											
HP	RPM	SP	63 Hz	125 Hz	250 Hz	500 Hz	1000 Hz	2000 Hz	4000 Hz	8000 Hz	L_{w_i} A
1/6	1720	0	67	75	78	72	66	63	61	55	74
		0.5	70	75	76	69	62	60	58	52	71

Model 5DDD128A; Wheel Dia. 12-1/4" Sound Data											
HP	RPM	SP	63 Hz	125 Hz	250 Hz	500 Hz	1000 Hz	2000 Hz	4000 Hz	8000 Hz	L_{w_i} A
1/12	880	0	59	68	66	61	60	55	47	40	64
		0.25	56	64	63	58	52	47	41	37	59

Model 5DDD12CA; Wheel Dia. 12-1/4" Sound Data											
HP	RPM	SP	63 Hz	125 Hz	250 Hz	500 Hz	1000 Hz	2000 Hz	4000 Hz	8000 Hz	L_{w_i} A
1/3	1694	0	77	79	81	78	72	70	67	59	79
		0.5	76	79	81	76	68	67	65	57	77
		1	76	78	79	74	66	66	63	58	76

Model 5DDD138A; Wheel Dia. 13-1/2" Sound Data											
HP	RPM	SP	63 Hz	125 Hz	250 Hz	500 Hz	1000 Hz	2000 Hz	4000 Hz	8000 Hz	L_{w_i} A
1/12	869	0	62	71	70	68	55	56	50	44	68
		0.25	62	69	68	68	56	52	46	42	67

Model 5DDD13DB; Wheel Dia. 13-1/2" Sound Data											
HP	RPM	SP	63 Hz	125 Hz	250 Hz	500 Hz	1000 Hz	2000 Hz	4000 Hz	8000 Hz	L_{w_i} A
1/2	1684	0	73	77	85	79	71	69	68	65	80
		0.5	72	77	84	78	70	68	67	63	79
		1	71	77	82	76	68	67	66	62	78
		1.5	72	76	80	74	67	66	65	61	76

Model 5DDD15AA; Wheel Dia. 15" Sound Data											
HP	RPM	SP	63 Hz	125 Hz	250 Hz	500 Hz	1000 Hz	2000 Hz	4000 Hz	8000 Hz	L_{w_i} A
1/6	866	0	65	76	72	66	62	61	53	45	69
		0.25	63	73	70	64	60	58	50	43	67
		0.5	59	71	66	61	56	50	47	41	63

Model 5DDD15CA; Wheel Dia. 15" Sound Data											
HP	RPM	SP	63 Hz	125 Hz	250 Hz	500 Hz	1000 Hz	2000 Hz	4000 Hz	8000 Hz	L_{w_i} A
1/3	1124	0	73	76	81	78	75	68	66	66	79
		0.5	71	75	79	76	71	66	72	70	79

Model 5DDD16BA; Wheel Dia. 16-1/2" Sound Data											
HP	RPM	SP	63 Hz	125 Hz	250 Hz	500 Hz	1000 Hz	2000 Hz	4000 Hz	8000 Hz	L_{w_i} A
1/4	868	0	66	77	75	69	64	64	57	48	72
		0.25	65	77	74	68	66	62	54	45	71
		0.5	65	74	70	65	62	56	51	43	67

Model 5DDD16DB; Wheel Dia. 16-1/2" Sound Data											
HP	RPM	SP	63 Hz	125 Hz	250 Hz	500 Hz	1000 Hz	2000 Hz	4000 Hz	8000 Hz	L_{w_i} A
1/2	1143	0	71	77	85	77	68	69	66	58	79
		0.5	69	75	83	75	67	68	62	55	78
		1	71	73	78	71	64	63	58	53	73

Model 5DDD18CA; Wheel Dia. 18-1/4" Sound Data											
HP	RPM	SP	63 Hz	125 Hz	250 Hz	500 Hz	1000 Hz	2000 Hz	4000 Hz	8000 Hz	L_{w_i} A
1/3	856	0	69	79	77	71	65	63	59	52	73
		0.25	68	79	76	70	63	61	57	50	72
		0.5	67	78	74	68	62	60	56	49	71

Model 5DDD18EB; Wheel Dia. 18-1/4" Sound Data											
HP	RPM	SP	63 Hz	125 Hz	250 Hz	500 Hz	1000 Hz	2000 Hz	4000 Hz	8000 Hz	L_{w_i} A
3/4	1106	0	74	79	92	82	73	69	66	61	85
		0.5	72	77	92	81	72	67	64	60	85
		1	71	75	91	81	71	66	64	62	84

Centrifugal Ventilators

Direct-Drive Downblast Centrifugal Roof & Wall Ventilators – Performance Curves

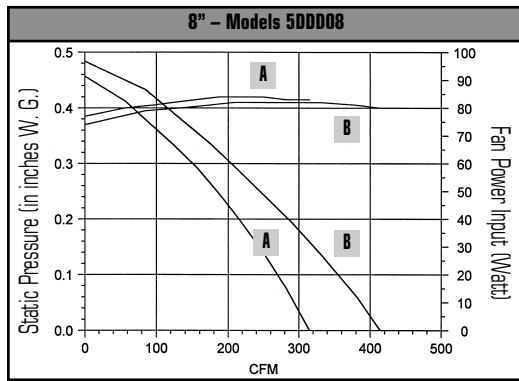

A = 5DDD084A, 1263 RPM
B = 5DDD085A, 1650 RPM

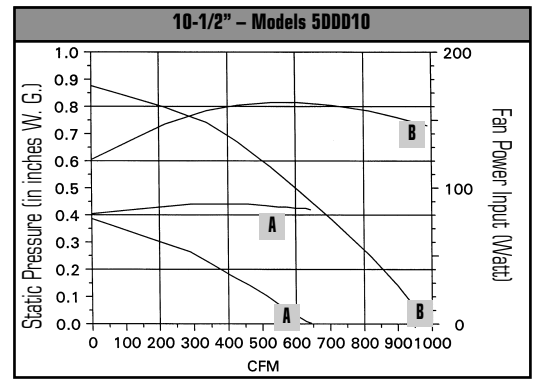

A = 5DDD106A, 1150 RPM
B = 5DDD10AA, 1720 RPM

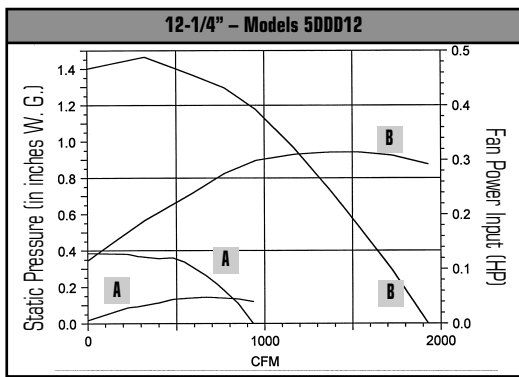

A = 5DDD128A, 880 RPM
B = 5DDD12CA, 1694 RPM

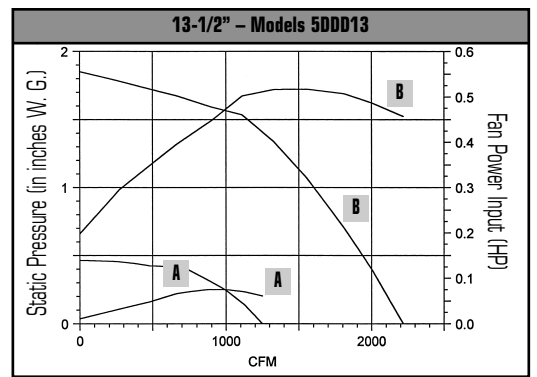

A = 5DDD138A, 870 RPM
B = 5DDD13DB, 1680 RPM

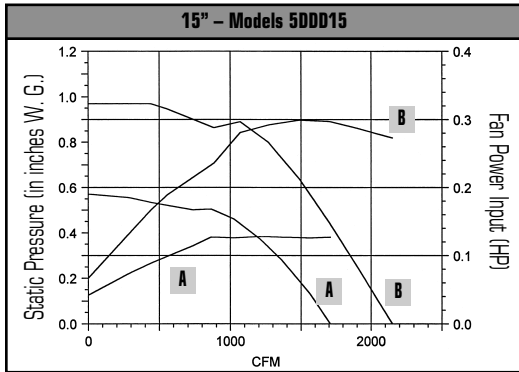

A = 5DDD15AA, 870 RPM
B = 5DDD15CA, 1145 RPM

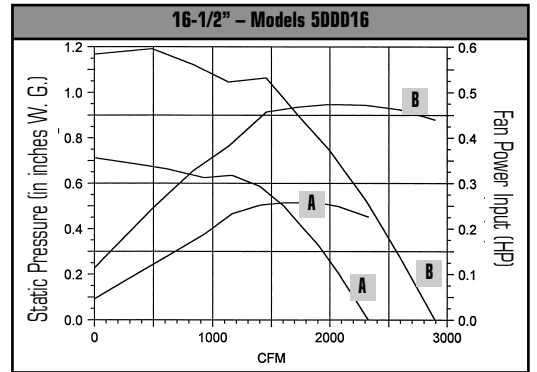

A = 5DDD168A, 870 RPM
B = 5DDD16DB, 1140 RPM

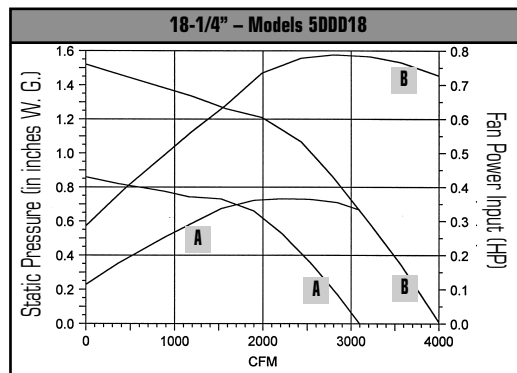

A = 5DDD18CA, 860 RPM
B = 5DDD18EB, 1110 RPM

Performance certified is for installation type A: free inlet, free outlet. Performance rating includes the effects of bird screen. Speed (RPM) shown is nominal, and performance is based on actual speed of test.

Centrifugal Ventilators

Belt-Drive Downblast Centrifugal Roof Ventilators

Belt-drive downblast ventilators are designed for roof mounted exhaust of commercial and industrial buildings.

Agency Listings

- All ventilators are UL Standard 705 listed when sold complete with motor and variable pitch drive
- All motor and drive packages comply with the minimum efficiency levels of EPA of '92. Affected motors bear the (EP) seal
- Ventilators are CSA listed according to Standard C22.2 No. 113-M1984 (Fans & Ventilators)

Features and Specifications

- Downblast discharge design exhausts foul air from industrial and commercial buildings
- Roof mount units only
- Models 5BDD13 – 5BDD49 available with hazardous location configuration
- Durable spun aluminum construction with steel support braces
- Backward inclined aluminum fan wheel
- Externally cooled motor compartment
- Inlet temperatures up to 170°F
- Built-in bird screen to protect discharge and ensure safe, obstruction-free operation



- Motor and wheel are easily detachable without removing ventilator from curb
- Uni-Mount motor structure
- Junction box mounted in motor compartment
- Windband rolled bead for added strength
- Welded curb cap corners eliminate water entry into ducts or building.
- Permanently lubricated ball bearings
- Regreaseable, pillow-block bearings factory installed on models 5BDD30 – 5BDD49
- Ball bearing motors and variable pitch drives are packed separately when ordered with ventilators
- 13" diameter and larger are available in explosion-proof construction with hazardous location motors (only available in 1/2 HP motors and larger)

Accessories (available separately)

- For more information, see Power Roof Ventilator Accessories
- Backdraft dampers.
- NEMA 1, NEMA 3R and NEMA 4 disconnect switches.
- Fixed mounting curbs available.

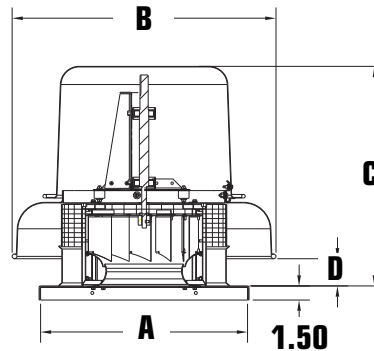

Fantech, Inc. and Systemair Mfg. Inc. certify that the Belt-Drive Downblast Centrifugal Roof Ventilators shown herein are licensed to bear the AMCA Seal. The ratings shown are based on tests and procedures performed in accordance with AMCA Publication 211 and AMCA Publication 311 and comply with the requirements of the AMCA Certified Ratings Program.

Model No.	Wheel Diameter (In.)	Wheel Bore Size (In.)	Pully Bore Size (In.)	Dimensions (In.)				Gauge Thickness (In.)				Max Ship Wt. (lbs.)	Optional Accessories			
				A	B	C	D	Baffle	Venturi	Dome	Recommended Roof Opening (In.)		Roof Mount Backdraft Damper Model No.	8" Ht. Model No.	12" Ht. Model No.	
5BDD10	10-1/2	1/2	7/8	19	25-3/4	22-7/8	3	0.05	0.05	0.1	70	14-1/2 x 14-1/2	5ACC12RD	5ACC17FS	5ACC17FT	
5BDD12	12-1/4	1/2	7/8	22	28	23-3/8	3	0.063	0.08	0.	84	17-1/2 x 17-1/2	5ACC15RD	5ACC20FS	5ACC20FT	
5BDD13	13-1/2	5/8	7/8	22	29-3/4	24-5/8	3-1/4	0.063	0.08	0.1	97	17-1/2 x 17-1/2	5ACC15RD	5ACC20FS	5ACC20FT	
5BDD15	15	5/8	7/8	26	31-11/16	27-3/8	3-3/4	0.063	0.08	0.08	119	21-1/2 x 21-1/2	5ACC19RD	5ACC24FS	5ACC24FT	
5BDD16	16-1/2	5/8	7/8	26	33-11/16	27-3/4	4-3/16	0.063	0.08	0.1	129	21-1/2 x 21-1/2	5ACC19RD	5ACC24FS	5ACC24FT	
5BDD18	18-1/4	5/8	7/8	30	36	29-5/8	4-3/4	0.063	0.08	0.08	141	25-1/2 x 25-1/2	5ACC23RD	5ACC28FS	5ACC28FT	
5BDD20	20	7/8	7/8	30	38-1/4	30-1/4	5-1/4	0.063	0.08	0.08	156	25-1/2 x 25-1/2	5ACC23RD	5ACC28FS	5ACC28FT	
5BDD24	24-1/2	7/8	7/8	34	44-1/4	33	6-11/16	0.063	0.08	0.08	177	29-1/2 x 29-1/2	5ACC27RD	5ACC32FS	5ACC32FT	
5BDD30	30	1	1	42	51-7/16	37-1/2	8-13/32	0.1	0.08	0.1	506	37-1/2 x 37-1/2	5ACC35RD	5ACC40FS	5ACC40FT	
5BDD36	36-1/2	1-3/16	1-3/16	46	60	41-5/8	10-1/2	0.1	0.09	0.1	524	43-1/2 x 43-1/2	5ACC39RD	5ACC44FS	5ACC44FT	
5BDD49	49	1-7/16	1-7/16	57	76-1/2	51-1/2	12-1/2	0.125	0.125	0.08	868	52-1/2 x 52-1/2	5ACC50RD	5ACC55FS	5ACC55FT	

MOTOR SELECTION GUIDE

Dia. (In.)	HP	Open Dripproof		Hazardous Location	
		Single Phase	Three Phase	Single Phase	Three Phase
10	1/6	AB	—	—	—
10-15	1/4	BB	—	—	—
12-24	1/3	CB	—	—	—
13-30	1/2	DB	DX	DL	DM
15-36	3/4	EB	EX	EL	EM
15-49	1	FB	FX	FL	FM

Dia. (In.)	HP	Open Dripproof		Hazardous Location	
		Single Phase	Three Phase	Single Phase	Three Phase
18-49	1-1/2	GB	GX	GL	GM
18-49	2	—	HX	—	HM
30-49	3	—	JX	—	JM
30-49	5	—	KX	—	KM
49	7-1/2	—	LX	—	LM

B = 115/230/60/1 Open Dripproof
 X = 208-220/440/60/3 Open Dripproof
 L = 115/230/60/1 Hazardous Location
 M = 230/460/60/3 Hazardous Location
 For fan with motor and drive package, add the two-digit motor HP, phase and enclosure code. Example: 5BDD10AB

Centrifugal Ventilators

Belt-Drive Downblast Centrifugal Roof Ventilators

5BDD10

HP	Motor Options	RPM	TS (FPM)	0.0" SP		0.125" SP		0.250" SP		0.375" SP		0.500" SP		0.625" SP		0.750" SP		0.875" SP		1.00" SP		1.25" SP		1.50" SP		1.75" SP						
				CFM		CFM		CFM		CFM		CFM		CFM		CFM		CFM		CFM		CFM		CFM		CFM		CFM		CFM		
				Sones†	BHP#	Sones†	BHP#	Sones†	BHP#	Sones†	BHP#	Sones†	BHP#	Sones†	BHP#	Sones†	BHP#	Sones†	BHP#	Sones†	BHP#	Sones†	BHP#	Sones†	BHP#	Sones†	BHP#	Sones†	BHP#	Sones†	BHP#	
1/6	AB	1452	3992	955		898		838		773		694																				
				9.8	0.11	9.5	0.12	9.0	0.12	8.5	0.12	8.0	0.13																			
		1506	4189	991		935		878		817		745		654																		
				10.2	0.12	10.2	0.13	9.9	0.13	9.4	0.14	8.9	0.14	8.4	0.14																	
		1589	3645	1046		992		939		880		816		741		642		455														
				11.2	0.15	11.1	0.15	10.9	0.16	10.3	0.16	9.7	0.17	9.5	0.17	9.1	0.16	9.0	0.15													
1/4	BB	1674	4602	1102		1052		1001		948		890		824		744																
				12.2	0.17	11.8	0.18	11.6	0.18	11.3	0.19	10.8	0.19	10.6	0.19	10.1	0.19															
		1736	4772	1142		1094		1045		995		941		880		808		721														
				12.8	0.19	12.9	0.20	12.5	0.20	12.4	0.21	12.0	0.21	11.5	0.22	10.9	0.22	10.7	0.22													
		1819	5000	1197		1151		1104		1055		1004		950		884		811		723		575										
				14.2	0.22	14.3	0.23	14.2	0.23	13.9	0.24	13.4	0.24	13.4	0.25	12.7	0.25	12.3	0.25	12.1	0.25	12.0	0.23									

5BDD12

HP	Motor Options	RPM	TS (FPM)	0.0" SP		0.125" SP		0.250" SP		0.375" SP		0.500" SP		0.625" SP		0.750" SP		0.875" SP		1.00" SP		1.25" SP		1.50" SP		1.75" SP					
				CFM		CFM		CFM		CFM		CFM		CFM		CFM		CFM		CFM		CFM		CFM		CFM		CFM		CFM	
				Sones†	BHP#	Sones†	BHP#	Sones†	BHP#	Sones†	BHP#	Sones†	BHP#	Sones†	BHP#	Sones†	BHP#	Sones†	BHP#	Sones†	BHP#	Sones†	BHP#	Sones†	BHP#	Sones†	BHP#	Sones†	BHP#	Sones†	BHP#
1/4	BB	1345	4312	1383		1309		1232		1148		1053		943		818															
				11.7	0.19	11.0	0.19	10.5	0.20	9.8	0.21	9.5	0.21	9.0	0.21	8.4	0.21														
		1394	4472	1434		1362		1289		1209		1120		1018		904		760													
				12.4	0.21	11.8	0.21	11.1	0.22	10.9	0.23	10.2	0.23	9.6	0.23	9.3	0.24	8.9	0.23												
		1423	4563	1464		1392		1321		1242		1158		1058		950		813													
				12.5	0.22	12.3	0.23	11.7	0.24	11.4	0.24	10.9	0.25	10.3	0.25	10.0	0.25	9.2	0.25												
1/3	CB	1480	4746	1522		1455		1386		1313		1233		1144		1043		932		785											
				13.4	0.25	12.7	0.25	12.5	0.26	12.0	0.27	11.2	0.28	10.9	0.28	10.4	0.28	10.0	0.28	9.8	0.28										
		1535	4922	1579		1514		1448		1378		1303		1220		1127		1025		910											
				14.3	0.27	13.5	0.28	13.2	0.29	12.6	0.30	12.0	0.31	11.8	0.31	11.2	0.31	11.0	0.31	10.7	0.31										
		1566	5022	1611		1546		1481		1414		1339		1260		1169		1074		966		805									
				13.1	0.29	13.1	0.30	12.7	0.31	12.7	0.32	12.3	0.32	11.7	0.33	11.0	0.33	10.8	0.33	10.3	0.33	10.2	0.32								

Performance certified is for installation type A: free inlet, free outlet. Performance rating includes the effects of bird screen.

Power rating (BHP) does not include transmission losses.

† The sound ratings shown are loudness values in fan sones at 5 ft. (1.5m) in a hemispherical free field calculated per AMCA standard 301. Values shown are for installation type A, free inlet hemispherical sone levels.

Centrifugal Ventilators

Belt-Drive Downblast Centrifugal Roof Ventilators

5BDD13

HP	Motor Options	RPM	TS (FPM)	0.0" SP		0.125" SP		0.250" SP		0.375" SP		0.500" SP		0.625" SP		0.750" SP		0.875" SP		1.00" SP		1.25" SP		1.50" SP		1.75" SP					
				CFM		CFM		CFM		CFM		CFM		CFM		CFM		CFM		CFM		CFM		CFM		CFM		CFM		CFM	
				Sones†	BHP#	Sones†	BHP#	Sones†	BHP#	Sones†	BHP#	Sones†	BHP#	Sones†	BHP#	Sones†	BHP#	Sones†	BHP#	Sones†	BHP#	Sones†	BHP#	Sones†	BHP#	Sones†	BHP#	Sones†	BHP#	Sones†	BHP#
1/4	BB	1124	3974	1549		1459		1360		1242		1111		965																	
				12.9	0.16	11.8	0.17	10.9	0.18	9.5	0.19	8.6	0.19	8.2	0.19																
		1166	4121	1607		1521		1427		1316		1192		1059		787															
				13.7	0.18	12.6	0.19	11.6	0.20	10.1	0.21	9.3	0.21	8.7	0.21	8.3	0.19														
		1213	4287	1672		1586		1500		1393		1279		1154		1009															
				14.0	0.21	13.4	0.22	12.3	0.23	11.1	0.23	10.0	0.24	9.3	0.24	9.3	0.24														
1/3	CB	1256	4438	1731		1651		1566		1469		1359		1241		1114		653													
				14.4	0.23	13.7	0.24	13.0	0.25	12.0	0.26	10.8	0.26	9.9	0.27	9.8	0.26	9.1	0.21												
		1295	4576	1785		1707		1626		1534		1429		1316		1198		1047													
				15.2	0.25	14.6	0.26	13.8	0.27	12.7	0.28	11.5	0.29	10.6	0.29	10.5	0.29	10.1	0.29												
		1335	4718	1840		1762		1684		1595		1498		1390		1277		1145		638											
				15.7	0.28	15.2	0.29	14.6	0.30	13.8	0.31	12.5	0.31	11.3	0.32	10.8	0.32	10.7	0.32	9.9	0.24										
1/2	DB	1397	4937	1925		1854		1779		1698		1607		1507		1401		1290		1156											
				16.6	0.32	15.9	0.33	15.6	0.34	14.9	0.35	13.7	0.36	12.8	0.36	12.1	0.37	11.6	0.37	11.3	0.36										
	1440	5091	1985		1915		1843		1766		1680		1584		1483		1377		1263												
			17.0	0.35	16.1	0.36	15.7	0.37	15.2	0.38	14.1	0.39	13.2	0.40	12.8	0.40	12.2	0.40	11.9	0.40											
	1528	5400	2106		2038		1969		1901		1820		1735		1645		1548		1446		1131										
			18.5	0.41	17.4	0.43	16.8	0.44	15.9	0.45	14.9	0.46	14.7	0.47	14.2	0.47	13.6	0.48	13.3	0.48	12.5	0.46									

5BDD15

HP	Motor Options	RPM	TS (FPM)	0.0" SP		0.125" SP		0.250" SP		0.375" SP		0.500" SP		0.625" SP		0.750" SP		0.875" SP		1.00" SP		1.25" SP		1.50" SP		1.75" SP					
				CFM		CFM		CFM		CFM		CFM		CFM		CFM		CFM		CFM		CFM		CFM		CFM		CFM		CFM	
				Sones†	BHP#	Sones†	BHP#	Sones†	BHP#	Sones†	BHP#	Sones†	BHP#	Sones†	BHP#	Sones†	BHP#	Sones†	BHP#	Sones†	BHP#	Sones†	BHP#	Sones†	BHP#	Sones†	BHP#	Sones†	BHP#	Sones†	BHP#
1/4	BB	944	3707	1877		1754		1611		1439		1241		500																	
				10.6	0.17	10.7	0.18	10.4	0.19	9.9	0.19	9.2	0.19	8.0	0.12																
		979	3844	1946		1828		1694		1531		1351		1112																	
				11.2	0.19	10.9	0.20	10.9	0.21	10.1	0.21	9.9	0.21	9.3	0.21																
		1033	4057	2054		1937		1816		1668		1503		1306		518															
				11.8	0.22	11.5	0.23	11.2	0.24	10.9	0.25	10.7	0.25	9.9	0.25	8.6	0.15														
1/3	CB	1068	4194	2123		2015		1898		1758		1603		1428		1200															
				12.3	0.24	12.0	0.25	11.8	0.27	11.5	0.27	10.9	0.28	10.6	0.28	10.0	0.27														
		1093	4291	2173		2068		1954		1820		1670		1506		1299															
				12.4	0.26	12.1	0.27	12.0	0.28	11.7	0.29	11.4	0.30	10.8	0.30	10.4	0.29														
		1136	4461	2259		2153		2047		1919		1782		1628		1446		1183													
				13.1	0.29	12.9	0.30	12.5	0.32	12.3	0.33	12.1	0.33	11.4	0.33	11.1	0.33	10.5	0.32												

Performance certified is for installation type A: free inlet, free outlet. Performance rating includes the effects of bird screen.

Power rating (BHP) does not include transmission losses.

† The sound ratings shown are loudness values in fan sones at 5 ft. (1.5m) in a hemispherical free field calculated per AMCA standard 301. Values shown are for installation type A, free inlet hemispherical sone levels.

Centrifugal Ventilators

Belt-Drive Downblast Centrifugal Roof Ventilators

5BDD15 *cont.*

HP	Motor Options	RPM	TS (FPM)	0.0" SP	0.125" SP	0.250" SP	0.375" SP	0.500" SP	0.625" SP	0.750" SP	0.875" SP	1.00" SP	1.25" SP	1.50" SP	1.75" SP			
				CFM	CFM	CFM	CFM	CFM	CFM	CFM	CFM	CFM	CFM	CFM	CFM	CFM	CFM	CFM
				Sones†	BHP#	Sones†	BHP#	Sones†	BHP#	Sones†	BHP#	Sones†	BHP#	Sones†	BHP#	Sones†	BHP#	Sones†
1/2	DB	1185	4652	2356	2259	2157	2041	1909	1768	1612	1419							
	DX			13.8	0.33	13.6	0.34	13.3	0.36	13.2	0.37	12.4	0.37	12.2	0.38	11.9	0.38	11.3
	DL	1222	4798	2430	2336	2237	2128	2002	1867	1723	1552	1335						
	DM			14.5	0.36	14.3	0.38	13.6	0.39	13.5	0.40	13.3	0.41	13.0	0.41	12.3	0.41	12.0
3/4	EB	1353	5314	2690	2605	2518	2425	2321	2205	2083	1956	1813	885					
				EX	16.2	0.49	16.2	0.51	16.1	0.52	15.6	0.54	15.3	0.55	15.1	0.55	14.9	0.56
	EL	1403	5510	2789	2708	2624	2536	2438	2330	2214	2094	1966	1646					
				EM	17.1	0.54	16.7	0.56	16.5	0.58	16.5	0.60	16.3	0.61	16.2	0.62	15.4	0.62
1	FB	1542	6056	3066	2992	2916	2838	2755	2664	2565	2459	2352	2118	1822				
				FX	18.7	0.72	18.6	0.74	18.3	0.76	18.1	0.78	18.0	0.80	17.9	0.81	17.1	0.82
	FL	1590	6243	3161	3089	3016	2941	2862	2776	2682	2582	2478	2260	1997	937			
				FM	19.0	0.79	19.0	0.81	18.9	0.83	18.8	0.85	18.5	0.87	18.5	0.88	18.2	0.89
FM	1639	6436	3259	3185	3112	3039	2965	2885	2791	2698	2604	2392	2153	1830				
			20	0.87	20	0.89	20	0.91	19.2	0.93	19.1	0.95	18.9	0.96	18.8	0.96	18.6	0.98

5BDD16

HP	Motor Options	RPM	TS (FPM)	0.0" SP	0.125" SP	0.250" SP	0.375" SP	0.500" SP	0.625" SP	0.750" SP	0.875" SP	1.00" SP	1.25" SP	1.50" SP	1.75" SP		
				CFM	CFM	CFM	CFM	CFM	CFM	CFM	CFM	CFM	CFM	CFM	CFM	CFM	CFM
				Sones†	BHP#	Sones†	BHP#	Sones†	BHP#	Sones†	BHP#	Sones†	BHP#	Sones†	BHP#	Sones†	BHP#
1/3	CB	865	3736	2219	2076	1920	1733	1499	1146								
				10.1	0.20	9.5	0.22	9.0	0.23	8.3	0.23	7.6	0.23	7.2	0.22		
		962	4156	2301	2164	2015	1842	1626	1365								
10.7	0.23			10.1	0.24	9.6	0.25	8.8	0.26	8.3	0.26	7.9	0.25				
1/2	DB	1004	4335	2576	2453	2325	2183	2019	1822	1599							
				DX	12.5	0.32	12.0	0.33	11.5	0.35	10.9	0.36	10.3	0.36	9.9	0.36	9.4
	DL	1041	4496	2671	2553	2430	2296	2144	1964	1760	1501						
				DM	12.9	0.35	12.6	0.37	12.1	0.38	11.6	0.39	11.0	0.40	10.4	0.41	10.0
DM	1100	4756	2825	2711	2597	2467	2330	2177	1999	1790	1491						
			14.1	0.42	13.6	0.43	13.4	0.45	12.8	0.46	12.2	0.47	11.7	0.48	11.2	0.48	11.0

Performance certified is for installation type A: free inlet, free outlet. Performance rating includes the effects of bird screen.

Power rating (BHP) does not include transmission losses.

† The sound ratings shown are loudness values in fan sones at 5 ft. (1.5m) in a hemispherical free field calculated per AMCA standard 301. Values shown are for installation type A, free inlet hemispherical sone levels.

Centrifugal Ventilators

Belt-Drive Downblast Centrifugal Roof Ventilators

5BDD16 cont.

HP	Motor Options	RPM	TS (FPM)	0.0" SP	0.125" SP	0.250" SP	0.375" SP	0.500" SP	0.625" SP	0.750" SP	0.875" SP	1.00" SP	1.25" SP	1.50" SP	1.75" SP		
				CFM	CFM	CFM	CFM	CFM	CFM	CFM	CFM	CFM	CFM	CFM	CFM	CFM	CFM
				Sones†	BHP#	Sones†	BHP#	Sones†	BHP#	Sones†	BHP#	Sones†	BHP#	Sones†	BHP#	Sones†	BHP#
3/4	EB	1147	4956	2943	2836	2726	2610	2483	2341	2176	1994	1788					
				15.1 0.47	14.4 0.49	14.3 0.51	13.8 0.52	13.0 0.53	12.8 0.54	12.3 0.54	11.8 0.54	11.3 0.53					
	EK	1171	5057	3004	2900	2792	2679	2557	2421	2265	2090	1899					
				15.8 0.50	15.1 0.52	15.0 0.54	14.3 0.55	13.9 0.56	13.1 0.57	12.8 0.58	12.3 0.58	11.9 0.57					
	EM	1261	5447	3235	3136	3036	2936	2817	2698	2579	2425	2269	1877				
				17.9 0.63	16.9 0.65	16.8 0.67	16.3 0.68	16.3 0.70	15.4 0.71	15.2 0.72	14.5 0.72	14.5 0.72	13.2 0.70				
1	FB	1294	5584	3321	3226	3129	3030	2925	2812	2689	2551	2398	2054				
				17.9 0.68	17.4 0.70	17.1 0.72	16.8 0.73	16.3 0.75	16.1 0.76	15.5 0.77	15.2 0.78	14.6 0.78	13.9 0.77				
	FK	1333	5757	3421	3329	3235	3139	3038	2931	2815	2688	2545	2226	1193			
				18.3 0.74	18.1 0.76	17.5 0.78	17.4 0.80	17.2 0.82	16.5 0.83	16.2 0.84	15.8 0.85	15.4 0.85	14.3 0.85	12.9 0.82			
	FL	1388	5996	3561	3471	3380	3290	3193	3085	2976	2868	2737	2448	2102			
				19.4 0.83	18.6 0.86	18.4 0.88	18.3 0.90	17.7 0.92	17.4 0.93	16.9 0.95	16.6 0.95	15.9 0.96	15.1 0.96	14.5 0.94			

5BDD18

HP	Motor Options	RPM	TS (FPM)	0.0" SP	0.125" SP	0.250" SP	0.375" SP	0.500" SP	0.625" SP	0.750" SP	0.875" SP	1.00" SP	1.25" SP	1.50" SP	1.75" SP		
				CFM	CFM	CFM	CFM	CFM	CFM	CFM	CFM	CFM	CFM	CFM	CFM	CFM	CFM
				Sones†	BHP#	Sones†	BHP#	Sones†	BHP#	Sones†	BHP#	Sones†	BHP#	Sones†	BHP#	Sones†	BHP#
1/3	CB	730	3489	2700	2505	2284	2026										
				8.4 0.21	8.1 0.22	7.6 0.24	7.0 0.24										
		757	3618	2800	2612	2403	2161	1865									
				9.5 0.23	8.8 0.25	8.4 0.26	8.0 0.27	7.5 0.27									
		811	3875	2999	2821	2631	2418	2168	1821								
				10.3 0.29	9.4 0.30	9.2 0.32	8.7 0.33	8.4 0.33	8.4 0.33								
1/2	DB	855	4083	3162	2997	2821	2622	2401	2139								
				10.5 0.34	10.2 0.35	9.9 0.37	9.4 0.38	8.9 0.39	8.6 0.39								
	DL	886	4235	3277	3117	2949	2762	2553	2318								
				10.7 0.37	10.6 0.39	10.4 0.41	10.0 0.42	9.8 0.43	9.2 0.44								
	DM	928	4434	3432	3276	3120	2939	2754	2533	2264							
				13.4 0.43	11.3 0.45	11.0 0.47	10.8 0.48	10.4 0.49	9.9 0.50	9.5 0.50							
3/4	EB	992	4738	3669	3527	3380	3222	3049	2862	2656	2407						
				13.0 0.52	12.5 0.55	12.4 0.57	12.1 0.59	11.6 0.60	11.4 0.61	10.9 0.61	10.2 0.61						
	EL	1021	4877	3776	3638	3496	3345	3180	3001	2807	2586						
				13.2 0.57	13.1 0.59	13.1 0.62	12.7 0.64	12.2 0.65	12.0 0.66	11.4 0.67	11.1 0.66						
	EM	1062	5074	3928	3791	3655	3514	3352	3190	3004	2811	2549					
				14.7 0.64	13.9 0.67	13.7 0.69	13.4 0.71	13.3 0.73	12.7 0.74	12.6 0.75	12.0 0.75	11.3 0.74					

Performance certified is for installation type A: free inlet, free outlet. Performance rating includes the effects of bird screen.

Power rating (BHP) does not include transmission losses.

† The sound ratings shown are loudness values in fan sones at 5 ft. (1.5m) in a hemispherical free field calculated per AMCA standard 301. Values shown are for installation type A, free inlet hemispherical sone levels.

Centrifugal Ventilators

Belt-Drive Downblast Centrifugal Roof Ventilators

5BDD18 cont.

HP	Motor Options	RPM	TS (FPM)	0.0" SP	0.125" SP	0.250" SP	0.375" SP	0.500" SP	0.625" SP	0.750" SP	0.875" SP	1.00" SP	1.25" SP	1.50" SP	1.75" SP								
				CFM	CFM	CFM	CFM	CFM	CFM	CFM	CFM	CFM	CFM	CFM	CFM	CFM	CFM	CFM					
				Sones†	BHP#	Sones†	BHP#	Sones†	BHP#	Sones†	BHP#	Sones†	BHP#	Sones†	BHP#	Sones†	BHP#	Sones†	BHP#				
1	FB	1100	5256	4068	3941	3810	3673	3526	3368	3199	3018	2815											
				15.4	0.71	15.2	0.74	14.6	0.76	14.4	0.79	14.1	0.80	13.9	0.82	13.3	0.83	13.0	0.83	12.4	0.83		
	FX	1134	5418	4194	4070	3944	3813	3672	3521	3361	3191	3005											
				16.2	0.78	15.9	0.81	15.9	0.83	15.2	0.86	15.0	0.88	14.7	0.89	14.5	0.90	13.9	0.91	13.3	0.91		
FL	1169	5585	4324	4199	4075	3951	3815	3667	3520	3354	3179	2726											
			17.5	0.86	16.8	0.89	16.7	0.91	16.5	0.93	15.9	0.96	15.5	0.97	15.4	0.99	14.7	0.99	14.5	1.00	13.0	0.99	
1-1/2	GB	1197	5719	4427	4310	4191	4068	3938	3800	3653	3498	3334	2950										
				17.9	0.92	17.7	0.95	17.1	0.97	17.0	1.00	16.7	1.02	16.5	1.04	16.2	1.05	15.5	1.06	15.3	1.07	13.9	1.07
	GX	1234	5897	4564	4450	4335	4216	4092	3961	3820	3673	3518	3171										
				18.9	1.01	18.8	1.04	18.5	1.06	18.4	1.09	17.8	1.11	17.4	1.13	17.2	1.15	16.8	1.16	16.3	1.17	15.3	1.18
GL	1338	6393	4949	4840	4732	4623	4515	4397	4268	4140	4011	3712	3372	2831									
			21	1.29	21	1.32	21	1.35	21	1.38	21	1.40	21	1.43	20	1.45	19.4	1.47	19.3	1.48	18.2	1.50	17.3
2	HX	1360	6497	5030	4927	4823	4717	4608	4494	4374	4248	4116	3836	3520									
				22	1.35	22	1.38	22	1.41	21	1.44	21	1.47	21	1.49	20	1.52	20	1.53	19.4	1.55	19.0	1.57
	HM	1388	6630	5134	5032	4931	4827	4721	4610	4494	4372	4244	3974	3675	3304								
				23	1.44	23	1.47	22	1.50	22	1.53	22	1.56	21	1.58	21	1.61	20	1.63	20	1.64	19.4	1.67
DM	1473	7038	5448	5349	5251	5152	5054	4956	4848	4731	4614	4381	4103	3825									
			26	1.72	25	1.75	24	1.78	24	1.82	24	1.88	24	1.88	23	1.90	22	1.93	22	1.95	22	1.98	21

5BDD20

HP	Motor Options	RPM	TS (FPM)	0.0" SP	0.125" SP	0.250" SP	0.375" SP	0.500" SP	0.625" SP	0.750" SP	0.875" SP	1.00" SP	1.25" SP	1.50" SP	1.75" SP			
				CFM	CFM	CFM	CFM	CFM	CFM	CFM	CFM	CFM	CFM	CFM	CFM	CFM	CFM	CFM
				Sones†	BHP#	Sones†	BHP#	Sones†	BHP#	Sones†	BHP#	Sones†	BHP#	Sones†	BHP#	Sones†	BHP#	Sones†
1/3	CB	634	3319	3025	2767	2500	2160	638										
				9.1	0.21	8.7	0.23	8.0	0.24	7.6	0.25	6.6	0.13					
		657	3442	3135	2886	2631	2320	1902										
10.1	0.23			9.3	0.26	8.7	0.27	8.1	0.28	7.7	0.27							
699	3660	3335	3101	2858	2588	2241												
		12.5	0.28	10.0	0.31	9.3	0.32	8.8	0.33	8.3	0.33							
1/2	DB	764	4002	3645	3431	3216	2990	2715	2388									
				11.5	0.37	11.0	0.39	10.5	0.41	9.7	0.43	9.3	0.44	9.1	0.43			
	DX	787	4119	3755	3547	3338	3122	2869	2562	1129								
				11.7	0.40	11.3	0.43	11.0	0.45	10.2	0.47	9.9	0.48	9.4	0.48	8.8	0.30	
DL	800	4189	3817	3612	3406	3188	2942	2653	2220									
			14.7	0.42	11.3	0.45	11.2	0.47	10.6	0.49	10.0	0.50	9.8	0.50	9.4	0.48		

Performance certified is for installation type A: free inlet, free outlet. Performance rating includes the effects of bird screen.

Power rating (BHP) does not include transmission losses.

† The sound ratings shown are loudness values in fan sones at 5 ft. (1.5m) in a hemispherical free field calculated per AMCA standard 301. Values shown are for installation type A, free inlet hemispherical sone levels.

Centrifugal Ventilators

Belt-Drive Downblast Centrifugal Roof Ventilators

5BDD20 cont.

HP	Motor Options	RPM	TS (FPM)	0.0" SP		0.125" SP		0.250" SP		0.375" SP		0.500" SP		0.625" SP		0.750" SP		0.875" SP		1.00" SP		1.25" SP		1.50" SP		1.75" SP					
				CFM		CFM		CFM		CFM		CFM		CFM		CFM		CFM		CFM		CFM		CFM		CFM		CFM		CFM	
				Sones†	BHP#	Sones†	BHP#	Sones†	BHP#	Sones†	BHP#	Sones†	BHP#	Sones†	BHP#	Sones†	BHP#	Sones†	BHP#	Sones†	BHP#	Sones†	BHP#	Sones†	BHP#	Sones†	BHP#	Sones†	BHP#	Sones†	BHP#
3/4	EB	854	4471	4075		3883		3691		3497		3286		3035		2746		1328													
				13.2	0.51	12.9	0.54	12.4	0.57	11.8	0.59	11.5	0.60	10.9	0.61	10.7	0.61	10.2	0.39												
	EX	879	4602	4194		4008		3821		3633		3434		3201		2929		2615													
				14.2	0.56	13.6	0.59	12.9	0.62	12.4	0.64	12.0	0.65	11.5	0.66	11.3	0.66	10.9	0.65												
EM	916	4796	4371		4192		4013		3828		3638		3429		3181		2895		2335												
			15.6	0.64	14.8	0.67	14.2	0.69	13.5	0.72	12.9	0.74	12.6	0.75	12.0	0.75	11.9	0.75	11.7	0.69											
1	FB	960	5028	4581		4410		4239		4068		3893		3705		3488		3239		2970											
				16.5	0.73	16.3	0.76	15.5	0.79	14.9	0.82	14.2	0.84	13.9	0.86	13.2	0.87	13.0	0.87	13.0	0.85										
	FX	989	5176	4719		4554		4388		4222		4054		3876		3675		3443		3193											
				17.6	0.80	17.0	0.83	16.3	0.86	15.7	0.89	15.5	0.91	14.5	0.93	14.5	0.94	13.6	0.95	13.6	0.94										
FL	1008	5278	4810		4647		4484		4322		4149		3976		3786		3560		3325		1186										
			18.7	0.85	17.7	0.88	17.1	0.91	16.4	0.94	16.0	0.96	15.4	0.98	14.6	1.00	14.5	1.00	14.4	1.00	13.3	0.57									
1-1/2	GB	1081	5660	5158		5006		4855		4703		4551		4396		4232		4050		3844		3381									
				22	1.04	20	1.08	19.6	1.11	18.8	1.15	18.8	1.17	17.7	1.20	17.6	1.22	16.7	1.23	16.7	1.24	15.9	1.22								
	GX	1113	5828	5311		5164		5016		4869		4722		4572		4416		4247		4057		3623		1597							
				22	1.14	21	1.18	21	1.21	19.8	1.25	18.9	1.27	18.8	1.30	18.4	1.32	17.6	1.34	17.3	1.35	16.7	1.34	15.9	0.84						
GL	1154	6042	5506		5364		5222		5080		4938		4787		4636		4484		4308		3913		3421								
			23	1.27	22	1.31	22	1.35	21	1.38	20	1.41	19.7	1.44	19.5	1.46	18.6	1.48	18.5	1.50	17.5	1.50	17.1	1.47							
2	HX	1224	6408	5840		5707		5573		5439		5305		5171		5034		4893		4744		4401		4004		3499					
				24	1.51	24	1.56	23	1.60	23	1.63	22	1.67	21	1.70	21	1.73	21	1.75	20	1.77	19.6	1.79	19.2	1.79	18.7	1.73				
	HM	1256	6576	5993		5863		5732		5602		5471		5340		5208		5073		4931		4611		4234		3813					
				25	1.64	25	1.68	24	1.72	23	1.76	23	1.80	22	1.83	22	1.86	22	1.88	21	1.90	20	1.94	20	1.94	19.7	1.90				
HM	1270	6650	6060		5931		5802		5673		5544		5413		5275		5138		5001		4685		4327		3888						
			26	1.69	25	1.74	24	1.78	24	1.82	23	1.85	23	1.89	22	1.92	22	1.95	22	1.97	21	2.00	20	2.01	19.7	1.97					

5BDD24

HP	Motor Options	RPM	TS (FPM)	0.0" SP		0.125" SP		0.250" SP		0.375" SP		0.500" SP		0.625" SP		0.750" SP		0.875" SP		1.00" SP		1.25" SP		1.50" SP		1.75" SP					
				CFM		CFM		CFM		CFM		CFM		CFM		CFM		CFM		CFM		CFM		CFM		CFM		CFM		CFM	
				Sones†	BHP#	Sones†	BHP#	Sones†	BHP#	Sones†	BHP#	Sones†	BHP#	Sones†	BHP#	Sones†	BHP#	Sones†	BHP#	Sones†	BHP#	Sones†	BHP#	Sones†	BHP#	Sones†	BHP#	Sones†	BHP#	Sones†	BHP#
1/3	CB	453	2904	3877		3447		2889																							
				8.0	0.22	7.9	0.24	7.5	0.25																						
		470	3012	4022		3611		3092		2319																					
				8.6	0.24	8.5	0.26	8.0	0.27	7.5	0.26																				
504	3233	4313		3931		3478		2877																							
		9.6	0.30	9.5	0.32	9.0	0.34	8.5	0.34																						

Performance certified is for installation type A: free inlet, free outlet. Performance rating includes the effects of bird screen.

Power rating (BHP) does not include transmission losses.

† The sound ratings shown are loudness values in fan sones at 5 ft. (1.5m) in a hemispherical free field calculated per AMCA standard 301. Values shown are for installation type A, free inlet hemispherical sone levels.

Centrifugal Ventilators

Belt-Drive Downblast Centrifugal Roof Ventilators

5BDD24 cont.

HP	Motor Options	RPM	TS (FPM)	0.0" SP		0.125" SP		0.250" SP		0.375" SP		0.500" SP		0.625" SP		0.750" SP		0.875" SP		1.00" SP		1.25" SP		1.50" SP		1.75" SP					
				CFM		CFM		CFM		CFM		CFM		CFM		CFM		CFM		CFM		CFM		CFM		CFM		CFM		CFM	
				Sones†	BHP#	Sones†	BHP#	Sones†	BHP#	Sones†	BHP#	Sones†	BHP#	Sones†	BHP#	Sones†	BHP#	Sones†	BHP#	Sones†	BHP#	Sones†	BHP#	Sones†	BHP#	Sones†	BHP#	Sones†	BHP#	Sones†	BHP#
1/2	DB	523	3352	4476		4112		3685		3147																					
				10.1	0.34	10.2	0.36	9.5	0.38	9.0	0.38																				
	DX	542	3476	4639		4288		3886		3383		2653																			
				10.5	0.37	10.4	0.40	10.3	0.42	9.6	0.42	9.1	0.40																		
DL	577	3701	4938		4605		4233		3795		3253																				
			11.8	0.45	11.7	0.48	11.7	0.50	11.0	0.51	10.2	0.50																			
3/4	EB	610	3911	5221		4912		4576		4180		3710		3087																	
				13.2	0.53	13.1	0.56	13.1	0.59	12.4	0.60	11.7	0.60	11.1	0.58																
	EX	632	4056	5409		5112		4791		4421		3982		3487																	
				14.0	0.59	14.0	0.62	13.9	0.65	13.4	0.66	12.5	0.67	11.9	0.66																
EL	660	4233	5649		5358		5059		4707		4309		3844		2837																
			15.1	0.67	15.1	0.71	14.9	0.73	14.9	0.75	14.2	0.76	13.3	0.76	12.3	0.68															
1	FB	695	4457	5948		5679		5396		5082		4721		4309		3859															
				16.9	0.79	16.9	0.82	16.8	0.85	16.6	0.87	15.8	0.89	15.1	0.89	14.5	0.88														
	FX	715	4588	6119		5857		5584		5284		4944		4553		4135		3428													
				17.8	0.86	17.8	0.89	17.9	0.92	17.7	0.95	16.8	0.96	16.1	0.97	15.4	0.96	14.6	0.91												
FL	727	4663	6222		5959		5692		5389		5069		4689		4266		3705														
			18.0	0.90	18.0	0.97	18.0	0.97	17.9	1.00	17.4	1.01	17.0	1.02	16.0	1.01	15.6	0.98													
1-1/2	GB	770	4936	6590		6347		6097		5829		5533		5198		4827		4436		3864											
				18.8	1.07	18.7	1.11	18.7	1.14	18.6	1.17	18.5	1.19	17.8	1.21	16.9	1.21	16.3	1.20	16.2	1.16										
	GX	798	5118	6830		6596		6355		6101		5822		5512		5165		4796		4390											
				19.4	1.19	19.1	1.23	19.1	1.27	19.0	1.30	18.9	1.32	18.1	1.34	17.5	1.34	17.4	1.34	16.5	1.32										
GL	832	5337	7121		6892		6659		6426		6148		5868		5554		5212		4823												
			19.8	1.35	19.7	1.39	19.6	1.43	19.0	1.46	18.8	1.49	18.7	1.51	18.4	1.52	18.1	1.52	17.8	1.51											
2	HX	877	5626	7506		7293		7077		6852		6612		6353		6069		5757		5425		4663									
				21	1.58	21	1.62	21	1.66	20	1.70	20	1.74	20	1.76	19.8	1.78	19.5	1.79	19.3	1.78	19.0	1.75								
	HM	894	5732	7651		7443		7231		7011		6779		6527		6255		5955		5633		4935									
				22	1.67	22	1.72	21	1.76	21	1.80	21	1.83	21	1.86	20	1.88	20	1.89	20	1.89	19.5	1.86								
916	5875	7839		7633		7421		7209		6984		6730		6476		6199		5889		5195											
		22	1.80	22	1.85	22	1.89	22	1.93	22	1.97	21	2.00	21	2.02	21	2.03	21	2.03	20	2.01										

Performance certified is for installation type A: free inlet, free outlet. Performance rating includes the effects of bird screen.

Power rating (BHP) does not include transmission losses.

† The sound ratings shown are loudness values in fan sones at 5 ft. (1.5m) in a hemispherical free field calculated per AMCA standard 301. Values shown are for installation type A, free inlet hemispherical sone levels.

Centrifugal Ventilators

Belt-Drive Downblast Centrifugal Roof Ventilators

5BDD30

HP	Motor Options	RPM	TS (FPM)	0.0" SP		0.125" SP		0.250" SP		0.375" SP		0.500" SP		0.625" SP		0.750" SP		0.875" SP		1.00" SP		1.25" SP		1.50" SP		1.75" SP					
				CFM		CFM		CFM		CFM		CFM		CFM		CFM		CFM		CFM		CFM		CFM		CFM		CFM		CFM	
				Sones†	BHP#	Sones†	BHP#	Sones†	BHP#	Sones†	BHP#	Sones†	BHP#	Sones†	BHP#	Sones†	BHP#	Sones†	BHP#	Sones†	BHP#	Sones†	BHP#	Sones†	BHP#	Sones†	BHP#	Sones†	BHP#	Sones†	BHP#
1/2	DB	365	2864	5732		5049		4279																							
				11.5	0.31	9.0	0.33	8.5	0.35																						
	DX	378	2970	5936		5278		4558																							
				10.6	0.34	9.9	0.37	9.5	0.39																						
DL	412	3236	6470		5866		5234		4371																						
			10.7	0.44	10.8	0.47	10.5	0.50	10.0	0.50																					
3/4	EB	429	3370	6737		6158		5564		4831																					
				11.4	0.50	11.1	0.53	10.7	0.56	10.3	0.57																				
	EX	444	3487	6972		6412		5843		5174																					
				11.6	0.55	11.7	0.59	11.4	0.62	10.6	0.63																				
EM	471	3699	7396		6869		6326		5732		4906																				
			12.5	0.66	12.1	0.70	11.8	0.73	11.5	0.75	11.0	0.74																			
1	FB	486	3817	7632		7121		6606		6054		5354																			
				12.6	0.73	12.9	0.76	12.5	0.80	11.7	0.82	11.3	0.82																		
	FX	502	3945	7883		7388		6891		6367		5732		4686																	
				13.4	0.80	13.1	0.84	12.8	0.87	12.3	0.90	11.6	0.91	11.4	0.86																
FL	519	4076	8150		7672		7188		6681		6084		5257																		
			13.5	0.89	13.5	0.92	13.0	0.96	12.7	1.00	12.3	1.01	11.6	0.98																	
1-1/2	GB	570	4476	8951		8515		8078		7637		7164		6607		5901															
				15.1	1.17	15.0	1.22	15.0	1.26	14.2	1.30	13.8	1.33	13.5	1.33	12.9	1.31														
	GX	586	4602	9202		8778		8354		7925		7475		6959		6328															
				15.8	1.28	15.7	1.32	15.5	1.36	14.9	1.40	14.2	1.44	13.8	1.45	13.6	1.43														
GL	594	4665	9227		8910		8490		8058		7619		7099		6515		4859														
			16.1	1.33	15.8	1.37	15.6	1.41	15.0	1.46	14.8	1.49	12.9	1.51	13.9	1.50	13.1	1.29													
2	HX	630	4948	9893		9499		9104		8708		8303		7866		7363		6760		4232											
				17.4	1.58	17.2	1.63	16.8	1.68	16.5	1.72	16.1	1.76	15.2	1.79	14.9	1.80	14.4	1.78	13.7	1.35										
	HM	645	5070	10128		9744		9358		8971		8578		8161		7689		7133		6398											
				17.8	1.70	17.5	1.75	17.4	1.79	16.9	1.84	16.4	1.88	16.1	1.92	15.3	1.93	15.2	1.92	14.6	1.87										
JM	653	5129	10254		9875		9493		9111		8708		8305		7826		7311		6545												
			17.8	1.76	17.8	1.81	17.5	1.86	16.9	1.91	16.7	1.96	16.3	1.99	15.3	2.00	15.3	1.99	15.1	1.95											
3	JX	700	5501	10992		10638		10283		9926		9568		9201		8812		8376		7876		4295									
				19.7	2.17	19.6	2.22	19.1	2.28	18.8	2.33	18.5	2.38	17.6	2.42	17.3	2.46	16.9	2.47	16.4	2.46	15.4	1.75								
	JM	718	5642	11275		10929		10583		10236		9888		9533		9161		8753		8291		7037									
				20	2.35	20	2.40	19.6	2.45	19.4	2.50	19.0	2.55	18.5	2.60	17.9	2.64	17.4	2.66	17.2	2.66	16.5	2.57								
JM	748	5875	11746		11416		11082		10749		10414		10062		9711		9357		8907		7855										
			21	2.65	21	2.71	21	2.76	20	2.82	19.9	2.87	19.7	2.92	19.2	2.97	18.3	3.00	18.1	3.01	17.8	2.96									

Performance certified is for installation type A: free inlet, free outlet. Performance rating includes the effects of bird screen.

Power rating (BHP) does not include transmission losses.

† The sound ratings shown are loudness values in fan sones at 5 ft. (1.5m) in a hemispherical free field calculated per AMCA standard 301. Values shown are for installation type A, free inlet hemispherical sone levels.

Centrifugal Ventilators

Belt-Drive Downblast Centrifugal Roof Ventilators

5BDD30 *cont.*

HP	Motor Options	RPM	TS (FPM)	0.0" SP		0.125" SP		0.250" SP		0.375" SP		0.500" SP		0.625" SP		0.750" SP		0.875" SP		1.00" SP		1.25" SP		1.50" SP		1.75" SP					
				CFM		CFM		CFM		CFM		CFM		CFM		CFM		CFM		CFM		CFM		CFM		CFM		CFM		CFM	
				Sones†	BHP#	Sones†	BHP#	Sones†	BHP#	Sones†	BHP#	Sones†	BHP#	Sones†	BHP#	Sones†	BHP#	Sones†	BHP#	Sones†	BHP#	Sones†	BHP#	Sones†	BHP#	Sones†	BHP#	Sones†	BHP#	Sones†	BHP#
5	KX	841	6606	13206		12911		12616		12320		12024		11727		11428		11123		10806		10103		9254		7914					
				26	3.77	26	3.83	26	3.89	26	3.95	25	4.01	25	4.07	25	4.13	24	4.19	23	4.23	22	4.28	22	4.25	21	4.04				
	KM	872	6645	13693		13408		13124		12839		12553		12267		11979		11689		11390		10744		9987		9050					
				29	4.20	29	4.27	29	4.33	28	4.39	27	4.45	27	4.52	27	4.58	26	4.64	25	4.69	24	4.76	23	4.76	23	4.68				
			887	6966	13928		13651		13370		13089		12808		12526		12238		11941		11645		11037		10278		9352				
					30	4.42	29	4.49	30	4.55	30	4.62	29	4.68	28	4.74	28	4.81	27	4.87	27	4.93	25	5.01	24	5.02	24	4.95			

5BDD36

HP	Motor Options	RPM	TS (FPM)	0.0" SP		0.125" SP		0.250" SP		0.375" SP		0.500" SP		0.625" SP		0.750" SP		0.875" SP		1.00" SP		1.25" SP		1.50" SP		1.75" SP					
				CFM		CFM		CFM		CFM		CFM		CFM		CFM		CFM		CFM		CFM		CFM		CFM		CFM		CFM	
				Sones†	BHP#	Sones†	BHP#	Sones†	BHP#	Sones†	BHP#	Sones†	BHP#	Sones†	BHP#	Sones†	BHP#	Sones†	BHP#	Sones†	BHP#	Sones†	BHP#	Sones†	BHP#	Sones†	BHP#	Sones†	BHP#	Sones†	BHP#
3/4	EB	293	2804	8671		7701		6396																							
				9.3	0.48	7.9	0.51	7.2	0.52																						
	EK	301	2878	8907		7970		6739																							
				9.8	0.52	8.5	0.55	7.7	0.56																						
EL	339	3239	10032		9207		8221		6803																						
			11.9	0.74	10.3	0.78	9.4	0.81	8.5	0.79																					
1	FB	350	3342	10357		9570		8642		7436																					
				12.0	0.81	10.7	0.86	9.8	0.88	9.1	0.88																				
	FX	356	3398	10535		9762		8861		7708																					
				12.1	0.86	11.1	0.90	10.2	0.93	9.3	0.93																				
FL	373	3564	11038		10288		9435		8397		6687																				
			13.6	0.98	12.0	1.03	11.0	1.07	10.3	1.07	10.0	1.00																			

Performance certified is for installation type A: free inlet, free outlet. Performance rating includes the effects of bird screen.
 # Power rating (BHP) does not include transmission losses.
 † The sound ratings shown are loudness values in fan sones at 5 ft. (1.5m) in a hemispherical free field calculated per AMCA standard 301. Values shown are for installation type A, free inlet hemispherical sone levels.

Centrifugal Ventilators

Belt-Drive Downblast Centrifugal Roof Ventilators

5BDD36 cont.

HP	Motor Options	RPM	TS (FPM)	0.0" SP		0.125" SP		0.250" SP		0.375" SP		0.500" SP		0.625" SP		0.750" SP		0.875" SP		1.00" SP		1.25" SP		1.50" SP		1.75" SP					
				CFM		CFM		CFM		CFM		CFM		CFM		CFM		CFM		CFM		CFM		CFM		CFM		CFM		CFM	
				Sones†	BHP#	Sones†	BHP#	Sones†	BHP#	Sones†	BHP#	Sones†	BHP#	Sones†	BHP#	Sones†	BHP#	Sones†	BHP#	Sones†	BHP#	Sones†	BHP#	Sones†	BHP#	Sones†	BHP#	Sones†	BHP#	Sones†	BHP#
1-1/2	GB	399	3811	11807		11124		10371		9472		8346																			
				14.2	1.21	13.3	1.26	12.6	1.30	11.8	1.31	10.8	1.30																		
	GX	409	3911	12103		11437		10711		9853		8807																			
				14.6	1.30	14.2	1.35	13.0	1.39	12.3	1.41	11.5	1.40																		
2	GL	427	4080	12636		11981		11302		10495		9541		8114																	
				16.7	1.48	14.9	1.53	14.1	1.58	13.7	1.61	12.9	1.61	12.8	1.55																
	GM	445	4252	13169		12559		11912		11176		10321		9278																	
				17.2	1.67	16.1	1.73	15.6	1.78	14.9	1.81	14.1	1.82	13.0	1.79																
3	HX	454	4342	13435		12838		12206		11496		10675		9698																	
				18.0	1.78	16.9	1.84	16.1	1.89	15.7	1.92	14.8	1.94	13.6	1.92																
	HM	470	4491	13908		13313		12718		12017		11284		10357		9030															
				19.5	1.97	18.2	2.03	17.8	2.09	16.8	2.13	16.1	2.15	15.0	2.14	14.9	2.07														
5	JX	520	4969	15388		14869		14332		13759		13125		12415		11616		10658													
				24	2.67	22	2.74	22	2.80	21	2.86	20	2.89	19.4	2.91	17.9	2.90	16.3	2.86												
	JM	531	5074	15713		15205		14682		14125		13513		12833		12073		11189													
				24	2.84	23	2.91	22	2.98	22	3.03	21	3.07	19.5	3.09	18.4	3.09	17.1	3.06												
5	KX	607	5799	15921		15401		14881		14352		13712		13071		12310		11486		10129											
							24	2.96	23	3.03	23	3.10	22	3.15	21	3.20	20	3.22	19.2	3.22	18.0	3.19	17.9	3.08							
	KM	620	5922	17962		17518		17067		16601		16107		15574		14997		14371		13687		11965									
							29	4.24	28	4.32	26	4.40	26	4.47	25	4.54	25	4.58	23	4.61	23	4.63	22	4.62	19.3	4.50					
5	KM	637	6087	18347		17913		17471		17017		16538		16024		15470		14870		14220		12661									
							29	4.52	28	4.60	27	4.68	27	4.76	26	4.82	25	4.88	24	4.91	23	4.93	23	4.92	20	4.84					
				18850		18411		17972		17533		17094		16563		16023		15482		14861		13469									
				28	4.90	28	4.99	29	5.08	28	5.15	27	5.22	27	5.28	25	5.32	25	5.34	23	5.35	23	5.33								

Performance certified is for installation type A: free inlet, free outlet. Performance rating includes the effects of bird screen.

Power rating (BHP) does not include transmission losses.

† The sound ratings shown are loudness values in fan sones at 5 ft. (1.5m) in a hemispherical free field calculated per AMCA standard 301. Values shown are for installation type A, free inlet hemispherical sone levels.

Centrifugal Ventilators

Belt-Drive Downblast Centrifugal Roof Ventilators

5BDD49

HP	Motor Options	RPM	TS (FPM)	0.0" SP		0.125" SP		0.250" SP		0.375" SP		0.500" SP		0.625" SP		0.750" SP		0.875" SP		1.00" SP		1.25" SP		1.50" SP		1.75" SP					
				CFM		CFM		CFM		CFM		CFM		CFM		CFM		CFM		CFM		CFM		CFM		CFM		CFM		CFM	
				Sones†	BHP#	Sones†	BHP#	Sones†	BHP#	Sones†	BHP#	Sones†	BHP#	Sones†	BHP#	Sones†	BHP#	Sones†	BHP#	Sones†	BHP#	Sones†	BHP#	Sones†	BHP#	Sones†	BHP#	Sones†	BHP#	Sones†	BHP#
1	FB	212	2717	14849		12993		10386																							
	FX			7.9	0.77	7.0	0.83	6.5	0.81																						
	FL	219	2808	15339		13555		11142																							
	FM			8.1	0.85	7.2	0.91	6.8	0.90																						
		228	2925	15969		14246		11996																							
				7.9	0.96	7.6	1.03	7.3	1.03																						
1-1/2	GB	247	3164	17300		15750		13874		11208																					
	GK			9.1	1.22	8.4	1.30	8.2	1.32	7.8	1.26																				
	GL	254	3255	17790		16288		14506		12081																					
	GM			9.4	1.33	8.7	1.41	8.6	1.43	8.1	1.39																				
		261	3348	18281		16812		15092		12849																					
				9.9	1.44	9.3	1.52	8.7	1.56	8.4	1.51																				
2	HX	265	3398	18561		17129		15469		13305																					
	HM			9.9	1.51	9.6	1.59	9.2	1.63	8.7	1.59																				
		276	3540	19331		17960		16408		14449																					
				10.6	1.70	10.1	1.79	9.7	1.84	9.4	1.81																				
		287	3682	20102		18766		17266		15459		12938																			
				11.3	1.92	10.8	2.01	10.3	2.07	10.2	2.05	9.6	1.97																		
3	JX	297	3810	20802		19535		18145		16484		14375																			
	JM			12.0	2.12	11.8	2.22	11.3	2.28	10.9	2.28	10.5	2.22																		
		313	4010	21923		20724		19431		17935		16102																			
				13.3	2.49	13.2	2.59	12.6	2.67	12.1	2.68	11.8	2.64																		
		329	4220	23044		21878		20671		19273		17614		15610																	
				14.0	2.89	13.8	3.00	13.5	3.08	13.5	3.12	13.0	3.09	12.6	3.01																

Performance certified is for installation type A: free inlet, free outlet. Performance rating includes the effects of bird screen.

Power rating (BHP) does not include transmission losses.

† The sound ratings shown are loudness values in fan sones at 5 ft. (1.5m) in a hemispherical free field calculated per AMCA standard 301. Values shown are for installation type A, free inlet hemispherical sone levels.

Centrifugal Ventilators

Belt-Drive Downblast Centrifugal Roof Ventilators

5BDD49 *cont.*

HP	Motor Options	RPM	TS (FPM)	0.0" SP		0.125" SP		0.250" SP		0.375" SP		0.500" SP		0.625" SP		0.750" SP		0.875" SP		1.00" SP		1.25" SP		1.50" SP		1.75" SP					
				CFM		CFM		CFM		CFM		CFM		CFM		CFM		CFM		CFM		CFM		CFM		CFM		CFM		CFM	
				Sones†	BHP#	Sones†	BHP#	Sones†	BHP#	Sones†	BHP#	Sones†	BHP#	Sones†	BHP#	Sones†	BHP#	Sones†	BHP#	Sones†	BHP#	Sones†	BHP#	Sones†	BHP#	Sones†	BHP#	Sones†	BHP#	Sones†	BHP#
5	KX	356	4563	24935		23885		22790		21589		20226		18623		16705															
				16.8	3.66	16.7	3.78	16.0	3.88	15.7	3.94	15.3	3.94	14.8	3.89	14.6	3.80														
		365	4687	25565		24541		23478		22323		21026		19522		17744															
	18.3			3.94	17.5	4.07	16.8	4.17	16.3	4.24	16.2	4.25	15.8	4.22	15.7	4.13															
	390	5003	27316		26333		25350		24280		23100		21848		20289		18571														
			28	4.81	19.7	4.95	19.0	5.06	18.3	5.15	17.8	5.19	17.4	5.18	17.6	5.11	17.1	5.02													
7-1/2	LX	413	5298	28927		28025		27101		26134		25087		23939		22653		21190		19519											
				21	5.71	21	5.85	21	5.98	19.8	6.09	19.8	6.15	19.3	6.16	18.7	6.13	18.9	6.05	18.8	5.95										
		420	5389	29417		28530		27625		26677		25658		24546		23309		21912		20326											
	22			6.01	22	6.15	21	6.28	21	6.39	20	6.46	19.7	6.48	19.6	6.46	19.2	6.39	19.0	6.29											
	447	5734	31308		30451		29593		28735		27768		26739		25709		24454		23093		19487										
			28	7.24	23	7.40	23	7.55	23	7.67	23	7.76	22	7.81	22	7.81	21	7.77	21	7.69	21	7.34									

Performance certified is for installation type A: free inlet, free outlet. Performance rating includes the effects of bird screen.

Power rating (BHP) does not include transmission losses.

† The sound ratings shown are loudness values in fan sones at 5 ft. (1.5m) in a hemispherical free field calculated per AMCA standard 301. Values shown are for installation type A, free inlet hemispherical sone levels.

Typical Specifications

Belt-Drive Downblast Roof

Roof mount exhaust fans shall be downblast centrifugal belt-driven type. The fan wheel shall be centrifugal backward inclined, blades and wheel cone to be constructed of aluminum and shall include a wheel cone matched to the inlet cone for precise running tolerances. Wheels shall be statically and dynamically balanced. The fan housing shall be constructed of heavy gauge aluminum with a rigid steel internal support structure. Baffles and motor compartment hoods shall have a rolled bead for added strength. Motors shall be heavy-duty ball bearing type, matched to the fan load, furnished at the specified voltage, phase and enclosure. Motors and drives shall be mounted out of the airstream. Fresh air for motor cooling shall be drawn into the motor compartments from an area free of discharge contaminants. Motors shall be readily accessible for maintenance. Steel shafts shall be turned, ground polished and mounted in permanently sealed and lubricated ball bearings (30" - 49" units feature regreaseable pillow block bearings). Bearings shall be selected for a minimum (L50) life in excess of 200,000 hours at maximum cataloged operating speed. Drives shall be sized for a minimum of 150% of driven horsepower. Pulleys shall be of the fully machined cast iron type, keyed and securely attached to the wheel and motor shafts. Motor pulleys shall be adjustable for final system balancing. A junction box shall be factory installed to permit a disconnect switch to be wired to the fan motor within the motor compartment. A conduit chase shall be provided through the curb cap to the motor compartment for ease of electrical wiring. All fans shall bear the AMCA Certified Ratings Seal for sound and air performance. Each fan shall bear a permanently affixed manufacturer's nameplate containing model number, drive selections and will carry a one-year warranty. Fans shall be Fantech Model Belt-Drive Downblast Centrifugal Roof Ventilators as manufactured by Systemair Mfg. Inc., Lenexa, Kansas.

Centrifugal Ventilators

Belt-Drive Downblast Centrifugal Roof Ventilators – Octave Sound Data

The sound power ratings shown are in decibels, referred to 10–12 Watts calculated per AMCA Standard 301. Values shown are for inlet Lwi A sound power levels for installation Type A: free inlet, free outlet. Ratings do not include the effects of duct end correction. For models shown on this page, the AMCA ratings seal applies to air performance and some values. For models shown on this page, the AMCA Certified Ratings Seal applies to air performance and some values only.

Model 5BDD10; Wheel Dia. 10-1/2" Sound Data											
HP	RPM	SP	63 Hz	125 Hz	250 Hz	500 Hz	1000 Hz	2000 Hz	4000 Hz	8000 Hz	LwiA
1/6	1589	0	69	70	77	71	64	64	60	55	73
		0.5	67	69	76	69	62	62	56	52	71
1/4	1819	0	71	74	79	80	67	67	64	59	79
		0.5	70	74	78	79	67	64	62	57	78

Model 5BDD12; Wheel Dia. 12-1/4" Sound Data											
HP	RPM	SP	63 Hz	125 Hz	250 Hz	500 Hz	1000 Hz	2000 Hz	4000 Hz	8000 Hz	LwiA
1/4	1423	0	71	74	80	71	65	68	63	55	75
		0.5	70	73	77	69	62	62	58	52	72
1/3	1566	0	72	76	82	74	67	71	67	59	78
		0.5	72	75	79	72	64	66	63	56	75
		1	71	74	76	71	63	62	59	54	73

Model 5BDD13; Wheel Dia. 13-1/2" Sound Data											
HP	RPM	SP	63 Hz	125 Hz	250 Hz	500 Hz	1000 Hz	2000 Hz	4000 Hz	8000 Hz	LwiA
1/4	1213	0	68	76	79	70	62	75	64	54	78
		0.5	67	75	76	68	61	63	56	51	71
1/3	1335	0	69	77	80	73	63	76	70	58	79
		0.5	68	77	78	71	62	70	60	54	75
1/2	1528	0	71	77	83	76	66	73	75	63	81
		0.5	70	77	82	75	65	73	69	59	79
		1	70	77	79	73	64	68	62	57	76

Model 5BDD15; Wheel Dia. 15" Sound Data											
HP	RPM	SP	63 Hz	125 Hz	250 Hz	500 Hz	1000 Hz	2000 Hz	4000 Hz	8000 Hz	LwiA
1/4	1033	0	68	76	79	70	65	66	58	55	74
		0.5	68	75	78	67	62	59	55	51	72
1/3	1136	0	69	76	81	72	66	67	62	57	76
		0.5	69	75	80	70	65	63	59	53	74
1/2	1301	0	70	77	84	75	68	68	67	60	78
		0.5	70	76	83	73	67	67	66	57	78
		1	71	75	80	70	64	64	59	56	75
3/4	1489	0	73	78	86	79	71	71	71	64	81
		0.5	72	77	85	78	70	70	70	62	81
		1	72	76	84	76	69	70	65	60	79
1	1639	0	75	80	86	83	74	73	73	67	84
		0.5	74	79	86	82	73	72	72	65	83
		1	74	78	85	80	71	71	70	63	81
		1.5	75	78	83	78	70	69	67	61	80

Model 5BDD16; Wheel Dia. 16-1/2" Sound Data											
HP	RPM	SP	63 Hz	125 Hz	250 Hz	500 Hz	1000 Hz	2000 Hz	4000 Hz	8000 Hz	LwiA
1/3	962	0	69	75	79	71	63	65	59	52	74
		0.5	68	72	75	68	63	61	55	48	71
1/2	1101	0	71	77	82	75	66	66	63	57	77
		.5	69	75	80	73	65	65	60	53	75
3/4	1261	0	73	78	86	79	69	68	67	62	81
		0.5	71	77	84	78	68	68	66	59	80
		1	73	76	81	75	66	67	62	57	77
1	1388	0	75	79	87	80	71	70	69	64	82
		0.5	73	79	86	79	70	70	68	62	81
		1	73	78	83	77	68	69	65	60	79

Model 5BDD18; Wheel Dia. 18-1/4" Sound Data											
HP	RPM	SP	63 Hz	125 Hz	250 Hz	500 Hz	1000 Hz	2000 Hz	4000 Hz	8000 Hz	LwiA
1/3	811	0	70	78	74	69	63	61	55	48	71
		0.5	69	75	71	65	63	57	52	46	69
1/2	928	0	71	79	77	72	66	64	58	52	74
		0.5	70	77	76	69	66	61	56	50	72
3/4	1062	0	73	80	81	75	69	67	62	57	77
		0.5	72	79	80	73	69	65	60	54	76
1	1169	0	74	81	84	78	72	70	65	61	80
		0.5	73	80	84	76	71	68	64	58	79
		1	72	77	81	74	69	66	62	57	77
1 1/2	1338	0	77	82	89	82	76	74	70	66	84
		0.5	76	82	89	81	75	73	69	64	84
		1	75	80	87	79	73	71	67	62	82
2	1473	0	79	84	91	84	78	76	73	68	87
		0.5	78	84	90	84	78	76	72	67	86
		1	78	82	89	82	76	74	70	65	85
		1.5	76	80	87	80	74	72	69	65	83

Model 5BDD20; Wheel Dia. 20" Sound Data											
HP	RPM	SP	63 Hz	125 Hz	250 Hz	500 Hz	1000 Hz	2000 Hz	4000 Hz	8000 Hz	LwiA
1/3	699	0	71	77	72	69	63	67	57	50	72
		0.5	70	74	69	68	65	58	51	46	69
1/2	800	0	74	78	77	72	65	68	61	54	75
		0.5	71	76	74	71	66	63	56	50	72
3/4	916	0	77	80	82	75	68	69	65	59	78
		0.5	73	78	79	74	68	67	61	55	76
1	1008	0	79	81	86	78	70	70	68	62	81
		0.5	75	80	83	77	70	69	65	59	79
		1	75	78	81	75	68	67	62	57	77
1 1/2	1154	0	81	83	90	81	74	73	71	67	84
		0.5	78	82	88	80	73	72	70	64	83
		1	76	80	86	78	71	70	67	62	81
2	1270	0	81	85	92	83	76	75	73	70	86
		0.5	79	84	90	82	75	74	72	68	85
		1	78	83	89	80	74	72	70	66	84
		1.5	78	82	88	79	73	72	69	64	83

Centrifugal Ventilators

Belt-Drive Downblast Centrifugal Roof Ventilators – Octave Sound Data

Model 5BDD24; Wheel Dia. 24-1/2" Sound Data											
HP	RPM	SP	63 Hz	125 Hz	250 Hz	500 Hz	1000 Hz	2000 Hz	4000 Hz	8000 Hz	LwiA
1/3	504	0	77	78	71	67	61	58	54	48	70
1/2	577	0	78	82	74	69	64	62	58	54	73
		0.5	75	79	73	68	62	60	55	52	71
3/4	660	0	80	86	78	72	67	66	63	60	76
		0.5	78	84	77	72	66	65	61	58	75
1	727	0	81	89	81	74	70	70	68	65	79
		0.5	80	88	80	74	69	69	66	62	79
1 1/2	832	0	80	88	85	79	73	72	69	67	82
		0.5	80	88	85	79	72	71	67	65	81
		1	76	85	84	77	70	69	66	63	80
2	916	0	80	88	88	83	75	73	69	69	84
		0.5	79	87	88	82	74	72	68	67	84
		1	77	85	88	81	72	70	67	65	83

Model 5BDD30; Wheel Dia. 30" Sound Data											
HP	RPM	SP	63 Hz	125 Hz	250 Hz	500 Hz	1000 Hz	2000 Hz	4000 Hz	8000 Hz	LwiA
1/2	412	0	75	82	70	67	66	59	54	48	71
3/4	471	0	76	83	73	69	68	62	57	52	73
		0.5	74	83	70	65	61	58	54	50	71
1	519	0	77	84	75	70	69	65	60	54	75
		0.5	75	84	73	68	64	60	56	53	73
1 1/2	594	0	78	86	79	72	71	69	64	59	78
		0.5	76	86	76	71	69	66	60	56	76
2	653	0	79	88	82	74	73	73	67	62	80
		0.5	78	88	79	73	72	70	64	59	78
3	748	0	81	89	87	77	76	76	71	66	83
		0.5	80	89	85	76	75	75	69	64	82
		1	79	87	83	75	73	71	66	61	80
5	887	0	83	90	94	82	80	80	78	72	89
		0.5	82	90	94	82	79	80	76	70	89
		1	81	89	92	81	78	79	73	68	87
		1.5	82	88	90	80	77	77	71	67	85

Model 5BDD36; Wheel Dia. 36-1/2" Sound Data											
HP	RPM	SP	63 Hz	125 Hz	250 Hz	500 Hz	1000 Hz	2000 Hz	4000 Hz	8000 Hz	LwiA
3/4	339	0	76	76	71	71	72	62	56	52	74
1	373	0	77	79	74	72	73	65	60	56	76
1 1/2	427	0	79	83	79	75	74	70	66	62	79
		0.5	75	78	75	72	71	65	62	60	75
2	470	0	80	86	84	77	75	75	70	66	82
		0.5	76	81	80	74	75	70	68	65	79
3	538	0	82	89	89	79	77	79	75	71	86
		0.5	79	87	86	77	78	75	72	68	83
5	637	0	84	93	95	83	80	80	77	73	89
		0.5	82	93	92	80	80	78	75	70	87
		1	80	89	87	79	78	75	72	68	84

Model 5BDD49; Wheel Dia. 49" Sound Data											
HP	RPM	SP	63 Hz	125 Hz	250 Hz	500 Hz	1000 Hz	2000 Hz	4000 Hz	8000 Hz	LwiA
1	228	0	77	73	71	64	60	56	52	50	68
1 1/2	261	0	79	77	73	66	63	58	55	52	70
2	287	0	81	80	74	68	65	61	57	54	72
		0.5	80	77	69	66	63	61	57	53	70
3	329	0	84	86	77	70	68	64	60	56	75
		0.5	82	82	73	70	67	64	62	56	74
5	390	0	87	92	82	74	72	69	65	60	80
		0.5	85	89	80	73	71	68	66	61	79
7 1/2	447	0	89	94	90	78	76	73	69	64	85
		0.5	87	92	88	77	74	71	69	64	83
		1	86	89	86	77	74	73	71	66	83

The AMCA Certified Ratings Seal applies to air performance and sound only.

Performance certified is for installation type A: free inlet, free outlet. Performance rating includes the effects of bird screen.

Centrifugal Ventilators

Belt-Drive Downblast Centrifugal Roof Ventilators – Performance Curves

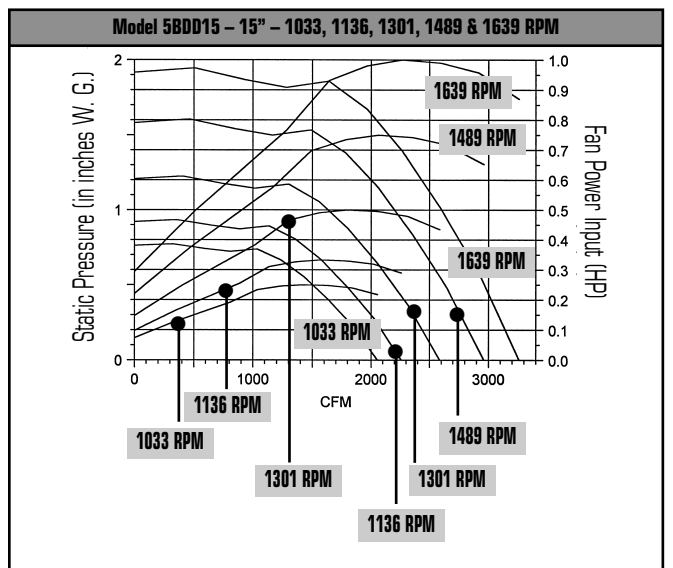
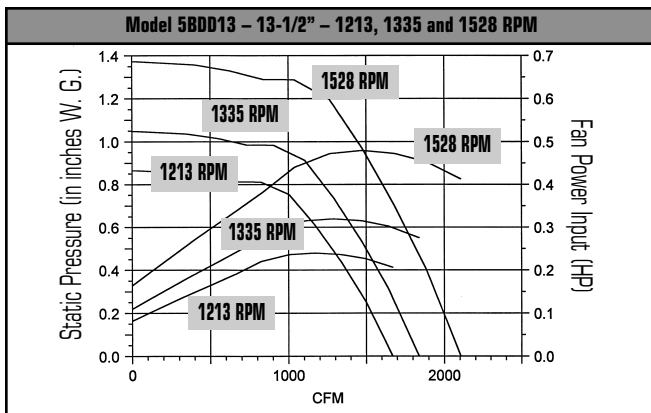
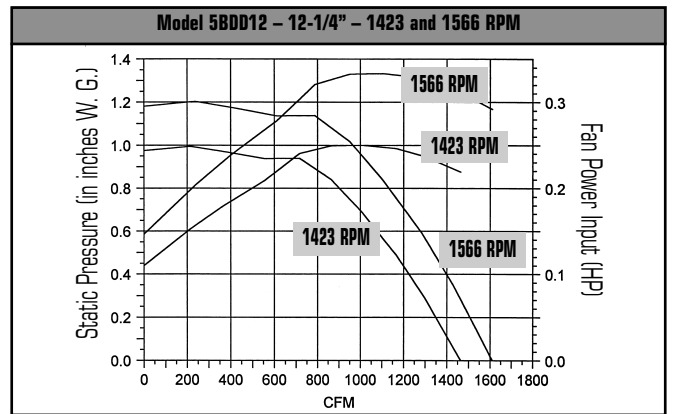
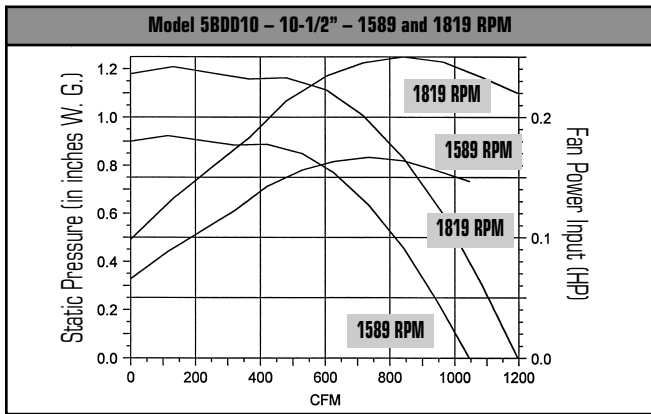

Performance certified is for installation type A: free inlet, free outlet. Performance rating includes the effects of bird screen.

Centrifugal Ventilators

Belt-Drive Downblast Centrifugal Roof Ventilators – Performance Curves

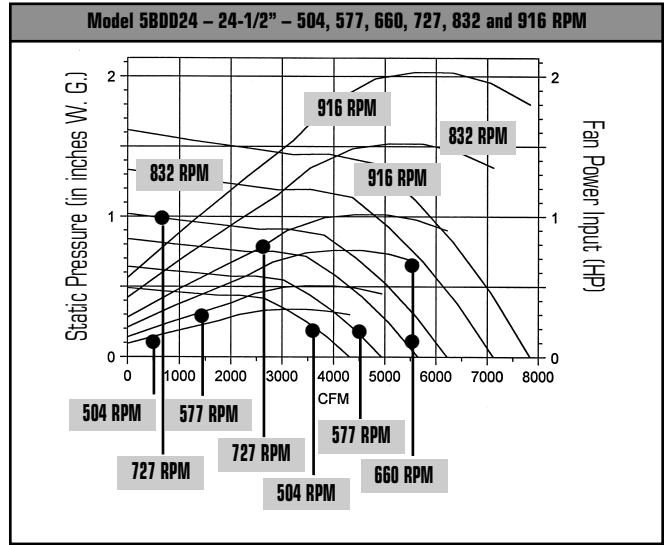
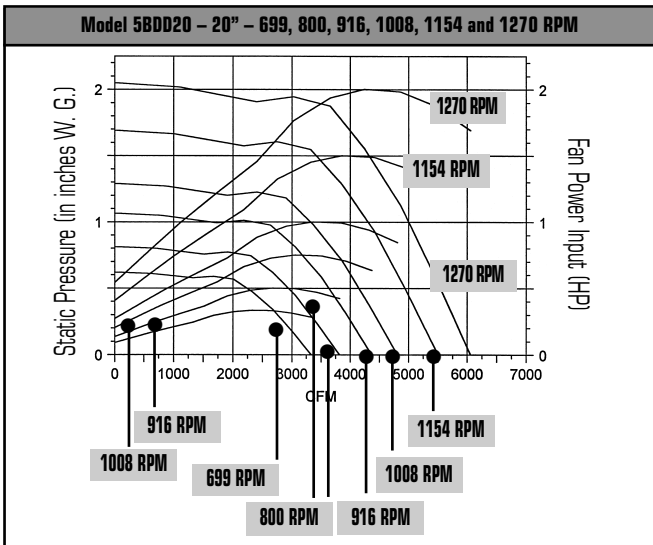
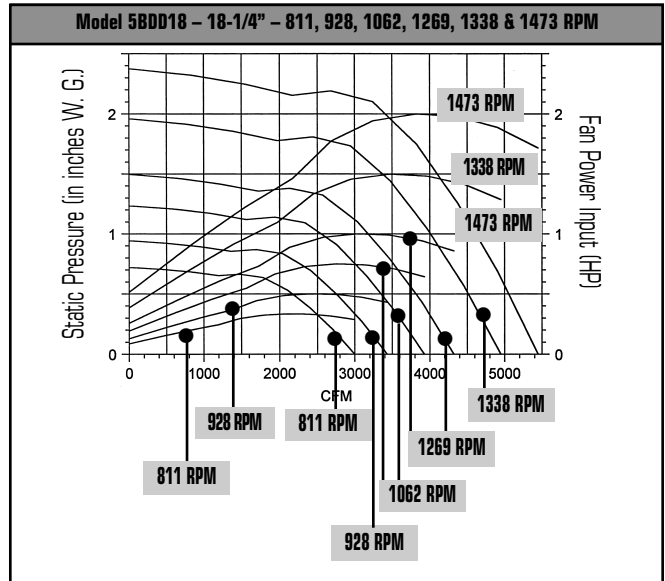
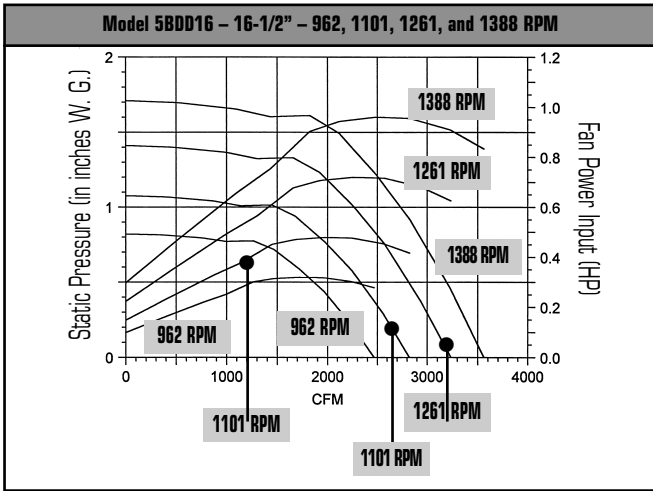

Performance certified is for installation type A: free inlet, free outlet. Performance rating includes the effects of bird screen.

Centrifugal Ventilators

Belt-Drive Downblast Centrifugal Roof Ventilators – Performance Curves

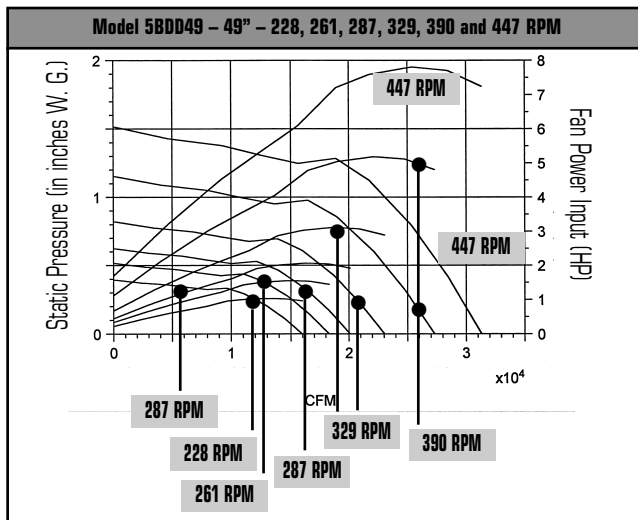
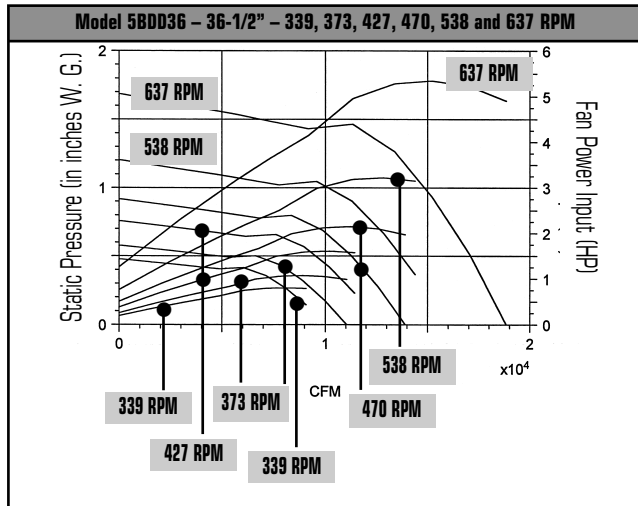
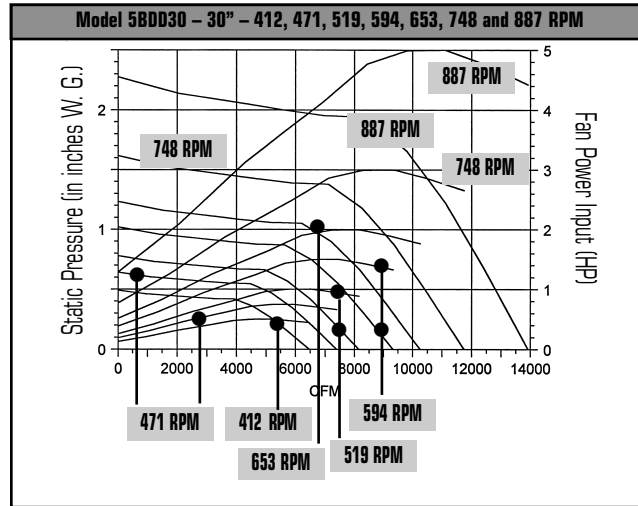

Performance certified is for installation type A: free inlet, free outlet. Performance rating includes the effects of bird screen.

Centrifugal Ventilators

Direct-Drive Upblast Centrifugal Roof & Wall Ventilators

Direct-drive upblast ventilators are designed for continuous operation to exhaust foul air, smoke, fumes, odors and grease-laden vapors from range hoods and commercial cooking appliances. Ventilators are designed for installation in industrial, institutional and commercial kitchen applications.

Agency Listings

- All ventilators are UL Standard 705 listed
- All ventilators are UL Standard 762 (Subject YZHW) listed (except 5DDU08)
- Complies with NFPA 96 application requirements (except 5DDU08)
- Ventilators are CSA listed according to Standard C22.2 No. 113-M1984 (Fans & Ventilators)

Features and Specifications

- Upblast discharge design
- Ventilators can be mounted on the roof or wall
- Spun aluminum construction with steel support braces
- Weather resistant aluminum windband, motor enclosure, and cover
- Backward inclined aluminum fan wheel
- Pre-wired Class B insulated ball bearing, 115V or 115/230V, 60 Hz motor
- Externally cooled motor compartment

- Inlet temperatures up to 300°F (except 5DDU08)
- Motor and wheel are easily detachable without removing ventilator from curb
- Junction box mounted in motor compartment
- A continuous venturi to windband weld virtually eliminates grease leakage
- Fully rolled windband bead for added strength, stability and ease of transport
- Welded curb cap corners eliminate water entry into ducts or building

Accessories (available separately)

- For more information, see Power Roof Ventilator Accessories
- NEMA 1, NEMA 3R and NEMA 4 disconnect switches.
- Fixed ventilated mounting curbs.
- Grease collector box.
- Hinge kit.
- Bird screen to protect discharge and ensure safe, obstruction-free operation.
- Speed controls (for UL 705 applications).
WARNING: Do not use a speed control in any kitchen exhaust application.
- Backdraft dampers.
WARNING: Do not use a damper in any kitchen exhaust application.

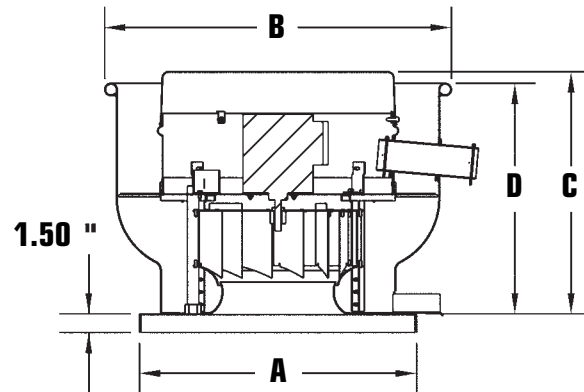

Fantech, Inc. and Systemair Mfg. Inc. certify that the Direct-Drive Upblast Centrifugal Roof & Wall Ventilators shown herein are licensed to bear the AMCA Seal. The ratings shown are based on tests and procedures performed in accordance with AMCA Publication 211 and AMCA Publication 311 and comply with the requirements of the AMCA Certified Ratings Program.

Model No.	Wheel Diameter (In.)	Wheel Bore Size (In.)	Dimensions (In.)				Gauge Thickness (In.)				Total Ship Wt. (lbs.)	Recommended Roof Opening (In.)	Optional Accessories		
			A	B	C	D	Windband	Venturi	Motor Enclosure	Hood			Roof Mount Backdraft Damper Model No.	Vented Roof Curb Model No.	Speed Control (115V Only) Model No.
5DDU085AW	8	5/16	19	20-1/2	12-1/8	10	0.063	0.05	N/A	0.04	30	14-1/2 x 14-1/2	5ACC12RD	5ACC17VC	5ACC03SC
5DDU085AY	8	5/16	19	20-1/2	12-1/8	10	0.063	0.05	N/A	0.04	30	14-1/2 x 14-1/2	5ACC12RD	5ACC17VC	5ACC03SC
5DDU106A	10-1/2	1/2	19	23-7/8	18-7/8	16-7/8	0.063	0.05	0.04	0.05	40	14-1/2 x 14-1/2	5ACC12RD	5ACC17VC	5ACC03SC
5DDU10AA	10-1/2	1/2	19	23-7/8	18-7/8	16-7/8	0.063	0.05	0.04	0.05	40	14-1/2 x 14-1/2	5ACC12RD	5ACC17VC	5ACC03SC
5DDU128A	12-1/4	1/2	22	26-1/6	19-5/8	17-3/4	0.063	0.063	0.04	0.05	45	17-1/2 x 17-1/2	5ACC15RD	5ACC20VC	5ACC03SC
5DDU12CA	12-1/4	1/2	22	26-1/6	19-5/8	17-3/4	0.063	0.063	0.04	0.05	45	17-1/2 x 17-1/2	5ACC15RD	5ACC20VC	5ACC06SC
5DDU138A	13-1/2	5/8	22	27-7/8	20-3/4	18-1/2	0.063	0.063	0.04	0.04	54	17-1/2 x 17-1/2	5ACC15RD	5ACC20VC	5ACC03SC
5DDU13DB	13-1/2	5/8	22	27-7/8	20-3/4	18-1/2	0.063	0.063	0.04	0.04	54	17-1/2 x 17-1/2	5ACC15RD	5ACC20VC	5ACC10SC
5DDU15AA	15	5/8	26	29-7/8	22	19-3/8	0.063	0.08	0.04	0.05	62	21-1/2 x 21-1/2	5ACC19RD	5ACC24VC	5ACC03SC
5DDU15CA	15	5/8	26	29-7/8	22	19-3/8	0.063	0.08	0.04	0.05	62	21-1/2 x 21-1/2	5ACC19RD	5ACC24VC	5ACC06SC
5DDU168A	16-1/2	5/8	26	31-3/4	22-3/4	20-1/6	0.063	0.063	0.04	0.05	72	21-1/2 x 21-1/2	5ACC19RD	5ACC24VC	5ACC06SC
5DDU16DB	16-1/2	5/8	26	31-3/4	22-3/4	20-1/6	0.063	0.063	0.04	0.05	72	21-1/2 x 21-1/2	5ACC19RD	5ACC24VC	5ACC10SC
5DDU18CA	18-1/4	5/8	30	34	24	21-1/8	0.063	0.08	0.04	0.04	92	25-1/2 x 25-1/2	5ACC23RD	5ACC28VC	5ACC06SC
5DDU18EB	18-1/4	5/8	30	34	24	21-1/8	0.063	0.08	0.04	0.04	92	25-1/2 x 25-1/2	5ACC23RD	5ACC28VC	5ACC10SC

Centrifugal Ventilators

Direct-Drive Upblast Centrifugal Roof & Wall Ventilators

Model No.	HP	RPM	TS (FPM)	.000" SP		.125" SP		.250" SP		.375" SP		.500" SP		.625" SP		.750" SP		.875" SP		1.000" SP		1.25" SP			
				Volts		CFM		CFM		CFM		CFM		CFM		CFM		CFM		CFM		CFM		CFM	
				FLA	Sones†	BHP	Sones†	BHP	Sones†	BHP	Sones†	BHP	Sones†	BHP	Sones†	BHP	Sones†	BHP	Sones†	BHP	Sones†	BHP	Sones†	BHP	Sones†
5DDU085AW	1/25	1660	3477	115		310		253		187		82													
				1.5	1.5	8.0	—	7.7	—	7.4	—	6.8	—												
5DDU085AY	1/25	1642	3439	115		416		349		267		169													
				1.0	2.3	8.0	—	7.1	—	6.5	—	6.8	—												
5DDU106A	1/20	1100	3023	115		685		548		388		116													
				1.7	4.0	5.1	—	4.5	—	3.9	—	4.1	—												
5DDU10AA	1/6	1725	4741	115		1048		979		911		836		749		650		522							
				1.8		12.6	—	12.3	—	11.6	—	11.3	—	10.6	—	10.8	—	10.5	—						
5DDU128A	1/12	880	2822	115		856		712		601															
				6.2/3.1		6.3	0.01	5.8	0.01	5.2	0.01														
5DDU12CA	1/3	1557	4993	115		1531		1469		1406		1340		1272		1193		1107		1007		897			
				2.4	4.4	13.8	0.27	13.5	0.29	13.3	0.31	12.9	0.32	12.6	0.33	12.3	0.34	12.0	0.35	11.6	0.35	11.3	0.33		
5DDU138A	1/12	870	3004	115		1221		1110		943		717													
				3.6		8.4	0.08	8.1	0.08	8.2	0.08	7.3	0.08												
5DDU13DB	1/2	1690	5832	115/230		2419		2352		2285		2218		2145		2072		1992		1910		1829		1631	
				6.2/3.1		20	0.54	20	0.55	19.5	0.56	19.0	0.58	18.6	0.59	18.2	0.60	17.9	0.62	17.4	0.62	17.4	0.63	15.6	0.63
5DDU15AA	1/6	867	3405	115		1668		1526		1370		1168		855											
				4.4		8.7	0.13	7.7	0.14	7.0	0.14	6.2	0.14	5.6	0.13										
5DDU15CA	1/3	1144	4492	115		2174		2070		1963		1849		1714		1568		1375		1100					
				8.4/4.2		13.5	0.27	13.0	0.28	12.5	0.30	12.0	0.31	11.4	0.32	10.8	0.32	10.0	0.30	9.0	0.29				
5DDU168A	1/4	870	3758	115		2264		2112		1954		1778		1558		1150									
				3.6		10.4	0.21	9.7	0.23	9.1	0.25	8.5	0.26	8.2	0.26	7.0	0.23								
5DDU16DB	1/2	1145	4946	115/230		2859		2739		2619		2494		2369		2219		2063		1847		1502			
				6.2/3.1		15.6	0.41	15.0	0.43	14.5	0.45	13.7	0.47	13.2	0.48	12.6	0.49	12.2	0.49	11.6	0.49	11.0	0.46		
5DDU18CA	1/3	858	4099	115		3051		2877		2688		2476		2246		1981		908							
				4.4		12.6	0.33	11.3	0.34	10.5	0.36	10.2	0.37	9.2	0.38	8.7	0.37	8.2	0.08						
5DDU18EB	3/4	1111	5308	115/230		3899		3787		3644		3495		3337		3181		3011		2836		2616		2031	
				8.4/4.2		21	0.73	21	0.75	20	0.78	19.8	0.80	18.9	0.81	18.0	0.83	17.3	0.84	17.3	0.86	16.9	0.85	16.2	0.80

Performance certified is for installation type A: free inlet, free outlet. Performance rating includes the effects of bird screen. Speed (RPM) shown is nominal, and performance is based on actual speed of test.

† The sound ratings shown are loudness values in fan sones at 5 ft. (1.5m) in a hemispherical free field calculated per AMCA standard 301. Values shown are for installation type A, free inlet hemispherical sone levels.

Typical Specifications:

Direct-Drive Upblast Roof & Wall Mount

Roof & wall mount exhaust fans shall be centrifugal upblast direct-drive type. The fan wheel shall be centrifugal backward inclined, blades and wheel cone to be constructed of aluminum and shall include a wheel cone matched to the inlet cone for precise running tolerances. Wheels shall be statically and dynamically balanced. The fan housing shall be constructed of heavy gauge aluminum with a rigid steel internal support structure. Windbands shall have a rolled bead for added strength and shall be joined to curb caps with a leak resistant, continuously welded seam. Motors shall be mounted out of the airstream. Fresh air for motor cooling shall be drawn into the motor compartment from an area free of discharge contaminants. Motors shall be readily accessible for maintenance. A junction box shall be factory installed to permit a disconnect switch to be wired to the fan motor within the motor compartment. A conduit chase shall be provided through the curb cap to the motor compartment for ease of electrical wiring. The drive assembly and wheel shall be removable from the support structure without disassembling the external fan housing. All fans shall bear the AMCA Certified Ratings Seal for sound and air performance. Each fan shall bear a permanently affixed manufacturer's nameplate containing model number and carry a one-year warranty. Fans shall be Fantech Model Direct-Drive Upblast Centrifugal Roof & Wall Ventilators as manufactured by Systemair Mfg. Inc., Lenexa, Kansas.

Direct Drive Centrifugal Wall Ventilators

Direct-Drive Sideblast Centrifugal Wall Ventilators

Direct-drive upblast ventilators are designed for continuous operation to exhaust foul air, smoke, fumes, odors and grease-laden vapors from range hoods and commercial cooking appliances. Ventilators are designed for installation in industrial, institutional and commercial kitchen applications.

Agency Listings

- All ventilators are UL Standard 705 listed
- All ventilators are UL Standard 762 (Subject YZHW) listed (except 5DDW08)
- Complies with NFPA 96 application requirements (except 5DDW08)
- Ventilators are CSA listed according to Standard C22.2 No. 113-M1984 (Fans & Ventilators)

Features and Specifications

- Upblast discharge design
- Spun aluminum construction with steel support braces
- Weather resistant aluminum windband, motor enclosure, and cover
- Backward inclined aluminum fan wheel
- Pre-wired Class B insulated ball bearing, 115V or 115/230V, 60 Hz motor

- Externally cooled motor compartment
- Inlet temperatures up to 300°F (except 5DDW08)
- Easy mounting wall plate
- Detachable venturi plate
- Motor and wheel are easily detachable without removing ventilator from curb
- Junction box mounted in motor compartment
- A continuous venturi to windband weld virtually eliminates grease leakage
- Fully rolled windband bead for added strength, stability and ease of transport

Accessories (available separately)

- For more information, see Power Roof Ventilator Accessories
- NEMA 1, NEMA 3R and NEMA 4 disconnect switches.
- Bird screen to protect discharge and ensure safe, obstruction-free operation.
- Speed controls (for UL 705 applications).
WARNING: Do not use a speed control in any kitchen exhaust application.
- Backdraft dampers. **WARNING: Do not use a damper in any kitchen exhaust application.**

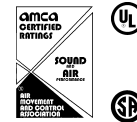
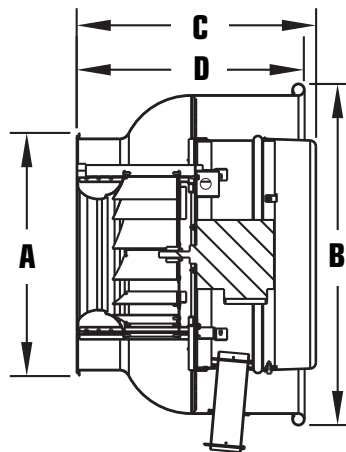

Fantech, Inc. and Systemair Mfg. Inc. certify that the Direct-Drive Upblast Centrifugal Roof Ventilators shown herein are licensed to bear the AMCA Seal. The ratings shown are based on tests and procedures performed in accordance with AMCA Publication 211 and AMCA Publication 311 and comply with the requirements of the AMCA Certified Ratings Program.

Model No.	Wheel Diameter (In.)	Wheel Bore Size (In.)	Dimensions (In.)				Gauge Thickness (In.)				Total Ship Wt. (lbs.)	Recommended Roof Opening (In.)	Optional Accessories	
			A	B	C	D	Windband	Venturi	Motor Enclosure	Hood			Wall Mount Backdraft Damper Model No.	Speed Control (115V Only) Model No.
5DDW085AW	8	5/16	14	20-1/2	12-1/8	10	0.063	0.05	NA	0.04	30	8-1/4x8-1/4	5ACC08WD	5ACC03SC
5DDW085AY	8	5/16	14	20-1/2	12-1/8	10	0.063	0.05	NA	0.04	30	8-1/4x8-1/4	5ACC08WD	5ACC03SC
5DDW106A	10-1/2	1/2	16-3/4	23-7/8	18-7/8	16-7/8	0.063	0.05	0.04	0.05	40	10-1/4x10-1/4	5ACC10WD	5ACC03SC
5DDW10AA	10-1/2	1/2	16-3/4	23-7/8	18-7/8	16-7/8	0.063	0.05	0.04	0.05	40	10-1/4x10-1/4	5ACC10WD	5ACC03SC
5DDW128A	12-1/4	1/2	18-1/2	26-1/6	19-5/8	17-3/4	0.063	0.063	0.04	0.05	45	11-1/4x11-1/4	5ACC11WD	5ACC03SC
5DDW12CA	12-1/4	1/2	18-1/2	26-1/6	19-5/8	17-3/4	0.063	0.063	0.04	0.05	45	11-1/4x11-1/4	5ACC11WD	5ACC06SC
5DDW138A	13-1/2	5/8	19-3/4	27-7/8	20-3/4	18-1/2	0.063	0.063	0.04	0.04	54	12-1/4x12-1/4	5ACC12WD	5ACC03SC
5DDW13DB	13-1/2	5/8	19-3/4	27-7/8	20-3/4	18-1/2	0.063	0.063	0.04	0.04	54	12-1/4x12-1/4	5ACC12WD	5ACC10SC
5DDW15AA	15	5/8	21-1/4	29-7/8	22	19-3/8	0.063	0.063	0.04	0.05	62	13-1/4x13-1/4	5ACC13WD	5ACC03SC
5DDW15CA	15	5/8	21-1/4	29-7/8	22	19-3/8	0.063	0.063	0.04	0.05	62	13-1/4x13-1/4	5ACC13WD	5ACC06SC
5DDW168A	16-1/2	5/8	22-3/4	31-3/4	22-3/4	20-1/6	0.063	0.063	0.04	0.05	72	14-1/4x14-1/4	5ACC14WD	5ACC06SC
5DDW16DB	16-1/2	5/8	22-3/4	31-3/4	22-3/4	20-1/6	0.063	0.063	0.04	0.05	72	14-1/4x14-1/4	5ACC14WD	5ACC10SC
5DDW18CA	18-1/4	5/8	24-1/2	34	24	21-1/8	0.063	0.08	0.04	0.04	92	15-1/4x15-1/4	5ACC15WD	5ACC06SC
5DDW18EB	18-1/4	5/8	24-1/2	34	24	21-1/8	0.063	0.08	0.04	0.04	92	15-1/4x15-1/4	5ACC15WD	5ACC10SC

Centrifugal Ventilators

Direct-Drive Sideblast Centrifugal Wall Ventilators

Model No.	HP	RPM	TS (FPM)	.000" SP		.125" SP		.250" SP		.375" SP		.500" SP		.625" SP		.750" SP		.875" SP		1.000" SP		1.25" SP			
				Volts	CFM	CFM	CFM	CFM	CFM	CFM	CFM	CFM	CFM	CFM	CFM	CFM	CFM	CFM	CFM	CFM	CFM	CFM	CFM	CFM	CFM
				FLA	Sones†	BHP	Sones†	BHP	Sones†	BHP	Sones†	BHP	Sones†	BHP	Sones†	BHP	Sones†	BHP	Sones†	BHP	Sones†	BHP	Sones†	BHP	Sones†
5DDW085AW	1/25	1660	3477	115	310	253	187	82																	
				1.5 1.5	8.0	—	7.7	—	7.4	—	6.8	—													
5DDW085AY	1/25	1642	3439	115	416	349	267	169																	
				1.0 2.3	8.0	—	7.1	—	6.5	—	6.8	—													
5DDW106A	1/20	1100	3023	115	685	548	388	116																	
				1.7 4.0	5.1	—	4.5	—	3.9	—	4.1	—													
5DDW10AA	1/6	1725	4741	115	1048	979	911	836	749	650	522														
				1.8	12.6	—	12.3	—	11.6	—	11.3	—	10.6	—	10.8	—	10.5	—							
5DDW128A	1/12	880	2822	115	856	712	601																		
				6.2/3.1	6.3	0.03	5.8	0.04	5.2	0.04															
5DDW12CA	1/3	1557	4993	115	1531	1469	1406	1340	1272	1193	1107	1007	897												
				2.4 4.4	13.8	0.27	13.5	0.29	13.3	0.31	12.9	0.34	12.6	0.35	12.3	0.36	12.0	0.35	11.6	0.35	11.3	0.34			
5DDW138A	1/12	870	3004	115	1221	1110	943	717																	
				3.6	8.4	0.08	8.1	0.08	8.2	0.08	7.3	0.08													
5DDW13DB	1/2	1690	5832	115/230	2419	2352	2285	2218	2145	2072	1992	1910	1829	1631											
				6.2/3.1	20	0.54	20	0.55	19.5	0.56	19.0	0.58	18.6	0.59	18.2	0.60	17.9	0.62	17.4	0.62	17.4	0.63	15.6	0.63	
5DDW15AA	1/6	867	3405	115	1668	1526	1370	1168	855																
				4.4	8.7	0.13	7.7	0.14	7.0	0.14	6.2	0.14	5.6	0.13											
5DDW15CA	1/3	1144	4492	115	2174	2070	1963	1849	1714	1568	1375	1100													
				8.4/4.2	13.5	0.27	13.0	0.28	12.5	0.30	12.0	0.31	11.4	0.32	10.8	0.32	10.0	0.30	9.0	0.29					
5DDW16BA	1/4	870	3758	115	2264	2112	1954	1778	1558	1150															
				3.6	10.4	0.21	9.7	0.23	9.1	0.25	8.6	0.26	8.2	0.26	7.0	0.23									
5DDW16DB	1/2	1145	4946	115/230	2859	2739	2619	2494	2369	2219	2063	1847	1502												
				6.2/3.1	15.6	0.41	15.0	0.43	14.5	0.45	13.7	0.47	13.2	0.48	12.6	0.49	12.8	0.49	11.6	0.49	11.0	0.46			
5DDW18CA	1/3	858	4099	115	3051	2877	2688	2476	2246	1981	908														
				4.4	12.6	0.33	11.3	0.34	10.5	0.36	10.2	0.37	9.2	0.38	8.7	0.37	8.2	0.24							
5DDW18EB	3/4	1111	5308	115/230	3899	3787	3644	3495	3337	3181	3011	2836	2616	2031											
				8.4/4.2	21	0.73	21	0.75	20	0.78	19.8	0.80	18.9	0.81	18.0	0.83	17.3	0.84	17.3	0.86	16.9	0.85	16.2	0.80	

Performance certified is for installation type A: free inlet, free outlet. Performance rating includes the effects of bird screen. Speed (RPM) shown is nominal, and performance is based on actual speed of test.

† The sound ratings shown are loudness values in fan sones at 5 ft. (1.5m) in a hemispherical free field calculated per AMCA standard 301. Values shown are for installation type A, free inlet, hemispherical sone levels.

Typical Specifications:

Direct-Drive Upblast Wall Mount

Wall mount exhaust fans shall be centrifugal upblast direct-drive type. The fan wheel shall be centrifugal backward inclined, blades and wheel cone to be constructed of aluminum and shall include a wheel cone matched to the inlet cone for precise running tolerances. Wheels shall be statically and dynamically balanced. The fan housing shall be constructed of heavy gauge aluminum with a rigid steel internal support structure. Windbands shall have a rolled bead for added strength. Motors shall be mounted out of the airstream. Fresh air for motor cooling shall be drawn into the motor compartment from an area free of discharge contaminants. Motors shall be readily accessible for maintenance. A junction box shall be factory installed to permit a disconnect switch to be wired to the fan motor within the motor compartment. A conduit chase shall be provided through the curb cap to the motor compartment for ease of electrical wiring. The drive assembly and wheel shall be removable from the support structure without disassembling the external fan housing. All fans shall bear the AMCA Certified Ratings Seal for sound and air performance. Each fan shall bear a permanently affixed manufacturer's nameplate containing model number and carry a one-year warranty. Fans shall be Fantech Model Direct-Drive Upblast Centrifugal Roof Ventilators as manufactured by Systemair Mfg. Inc., Lenexa, Kansas.

Centrifugal Ventilators

Direct-Drive Upblast Centrifugal Roof & Wall Ventilators – Octave Sound Data

The sound power ratings shown are in decibels, referred to 10^{-12} Watts calculated per AMCA Standard 301. Values shown are for inlet L_{w_i} A sound power levels for installation Type A: free inlet, free outlet. Ratings do not include the effects of duct end correction. For models shown on this page, the AMCA Certified Ratings Seal applies to air performance and sones only.

Model 5DDU085AW/5DDW085AW; Wheel Dia. 8" Sound Data											
HP	RPM	SP	63 Hz	125 Hz	250 Hz	500 Hz	1000 Hz	2000 Hz	4000 Hz	8000 Hz	L _{wi} A
1/25	1660	0	63	70	76	63	55	51	49	43	68
		0.13	69	70	75	62	54	51	48	42	67
		0.25	68	70	74	61	53	50	47	41	67

Model 5DDU13DB/5DDW13DB; Wheel Dia. 13-1/2" Sound Data											
HP	RPM	SP	63 Hz	125 Hz	250 Hz	500 Hz	1000 Hz	2000 Hz	4000 Hz	8000 Hz	L _{wi} A
1/2	1690	0	71	81	88	82	72	76	73	64	84
		0.5	70	80	86	80	71	74	69	61	82
		1	68	80	85	79	70	71	66	59	80

Model 5DDU085AY/5DDW085AY; Wheel Dia. 8" Sound Data											
HP	RPM	SP	63 Hz	125 Hz	250 Hz	500 Hz	1000 Hz	2000 Hz	4000 Hz	8000 Hz	L _{wi} A
1/25	1642	0	61	68	74	63	63	54	52	43	68
		0.13	60	68	73	61	57	52	49	42	66
		0.25	61	67	72	60	55	49	46	39	65

Model 5DDU15AA/5DDW15AA; Wheel Dia. 15" Sound Data											
HP	RPM	SP	63 Hz	125 Hz	250 Hz	500 Hz	1000 Hz	2000 Hz	4000 Hz	8000 Hz	L _{wi} A
1/6	867	0	63	76	72	66	62	64	51	43	70
		0.25	62	74	69	64	59	55	47	41	66
		0.5	62	71	66	60	52	49	44	41	62

Model 5DDU106A/5DDW106A; Wheel Dia. 10-1/2" Sound Data											
HP	RPM	SP	63 Hz	125 Hz	250 Hz	500 Hz	1000 Hz	2000 Hz	4000 Hz	8000 Hz	L _{wi} A
1/12	1100	0	61	68	69	57	61	53	46	36	65
		0.13	64	67	68	54	52	49	44	35	62
		0.25	65	67	66	52	49	46	42	34	59
		0.38	72	68	66	51	49	45	41	34	60

Model 5DDU15CA/5DDW15CA; Wheel Dia. 15" Sound Data											
HP	RPM	SP	63 Hz	125 Hz	250 Hz	500 Hz	1000 Hz	2000 Hz	4000 Hz	8000 Hz	L _{wi} A
1/3	1144	0	67	75	82	74	67	69	63	53	77
		0.5	65	74	80	71	66	65	56	48	74

Model 5DDU10AA/5DDW10AA; Wheel Dia. 10-1/2" Sound Data											
HP	RPM	SP	63 Hz	125 Hz	250 Hz	500 Hz	1000 Hz	2000 Hz	4000 Hz	8000 Hz	L _{wi} A
1/6	1725	0	67	74	79	72	67	69	64	55	76
		0.5	70	75	77	71	64	62	59	53	73

Model 5DDU16BA/5DDW16BA; Wheel Dia. 16-1/2" Sound Data											
HP	RPM	SP	63 Hz	125 Hz	250 Hz	500 Hz	1000 Hz	2000 Hz	4000 Hz	8000 Hz	L _{wi} A
1/4	870	0	66	76	75	69	62	62	57	56	71
		0.25	65	74	73	67	61	60	54	55	69
		0.5	66	73	71	65	61	56	51	53	68

Model 5DDU128A/5DDW128A; Wheel Dia. 12-1/4" Sound Data											
HP	RPM	SP	63 Hz	125 Hz	250 Hz	500 Hz	1000 Hz	2000 Hz	4000 Hz	8000 Hz	L _{wi} A
1/12	880	0	59	70	68	62	59	57	46	38	65
		0.25	57	66	64	63	55	47	40	38	62

Model 5DDU16DB/5DDW16DB; Wheel Dia. 16-1/2" Sound Data											
HP	RPM	SP	63 Hz	125 Hz	250 Hz	500 Hz	1000 Hz	2000 Hz	4000 Hz	8000 Hz	L _{wi} A
1/2	1145	0	70	78	84	78	68	67	64	59	79
		0.5	67	76	80	78	65	66	61	54	77
		1	67	73	77	74	65	62	58	51	74

Model 5DDU12CA/5DDW12CA; Wheel Dia. 12-1/4" Sound Data											
HP	RPM	SP	63 Hz	125 Hz	250 Hz	500 Hz	1000 Hz	2000 Hz	4000 Hz	8000 Hz	L _{wi} A
1/3	1557	0	69	76	81	75	67	65	65	57	77
		0.5	68	76	80	73	67	66	62	54	75
		1	65	74	78	71	67	65	58	53	74

Model 5DDU18CA/5DDW18CA; Wheel Dia. 18-1/4" Sound Data											
HP	RPM	SP	63 Hz	125 Hz	250 Hz	500 Hz	1000 Hz	2000 Hz	4000 Hz	8000 Hz	L _{wi} A
1/3	858	0	68	81	77	72	66	70	58	52	75
		0.25	68	78	75	70	68	64	55	49	73
		0.5	67	76	73	68	67	59	53	47	71

Model 5DDU138A/5DDW138A; Wheel Dia. 13-1/2" Sound Data											
HP	RPM	SP	63 Hz	125 Hz	250 Hz	500 Hz	1000 Hz	2000 Hz	4000 Hz	8000 Hz	L _{wi} A
1/12	870	0	62	72	70	69	66	58	49	46	70
		0.25	68	72	70	70	59	53	48	49	69

Model 5DDU18EB/5DDW18EB; Wheel Dia. 18-1/4" Sound Data											
HP	RPM	SP	63 Hz	125 Hz	250 Hz	500 Hz	1000 Hz	2000 Hz	4000 Hz	8000 Hz	L _{wi} A
3/4	1111	0	72	81	92	79	71	69	66	61	84
		0.5	70	81	90	78	69	71	63	58	82
		1	69	79	88	75	69	68	60	55	81

Centrifugal Ventilators

Direct-Drive Upblast Centrifugal Roof & Wall Ventilators – Performance Curves

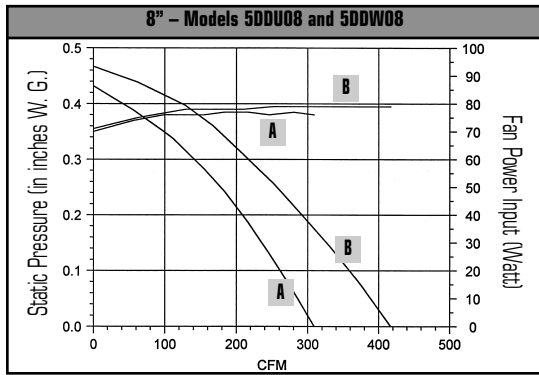

A = 5DDU085AW, 5DDW085AW, 1660 RPM
B = 5DDU085AY, 5DDW085AY, 1642 RPM

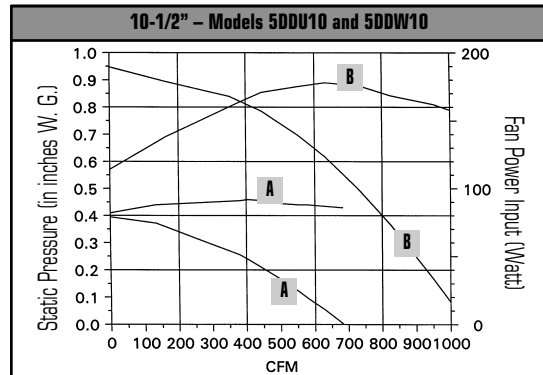

A = 5DDU106A, 5DDW106A, 1100 RPM
B = 5DDU10AA, 5DDW10AA, 1725 RPM

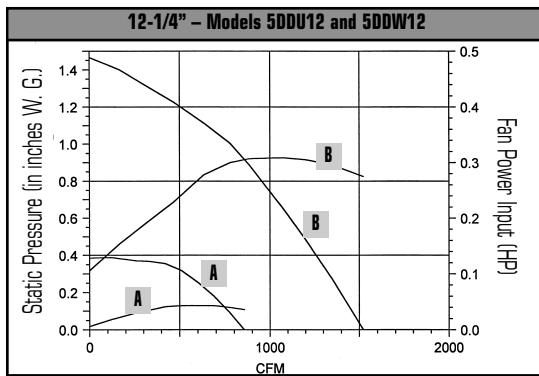

A = 5DDU128A, 5DDW128A, 880 RPM
B = 5DDU12CA, 5DDW12CA, 1557 RPM

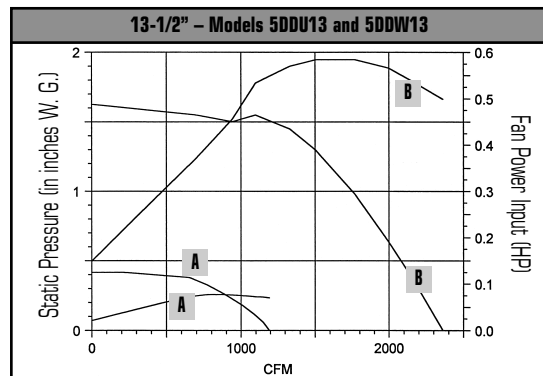

A = 5DDU138A, 5DDW138A, 870 RPM
B = 5DDU13DB, 5DDW13DB, 1690 RPM

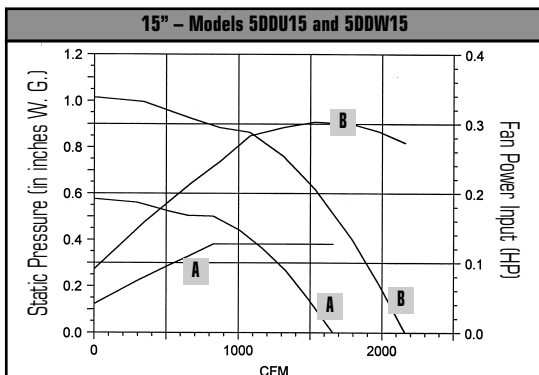

A = 5DDU15AA, 5DDW15AA, 867 RPM
B = 5DDU15CA, 5DDW15CA, 1144 RPM

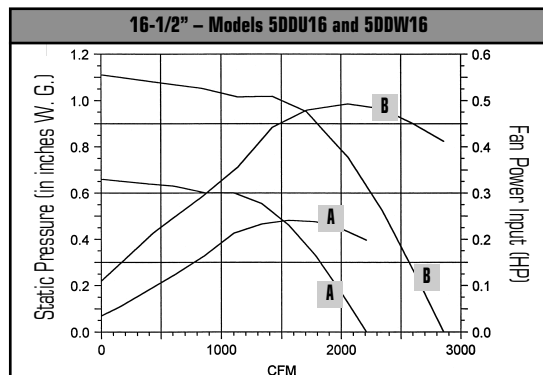

A = 5DDU16BA, 5DDW16BA, 870 RPM
B = 5DDU16DB, 5DDW16DB, 1145 RPM

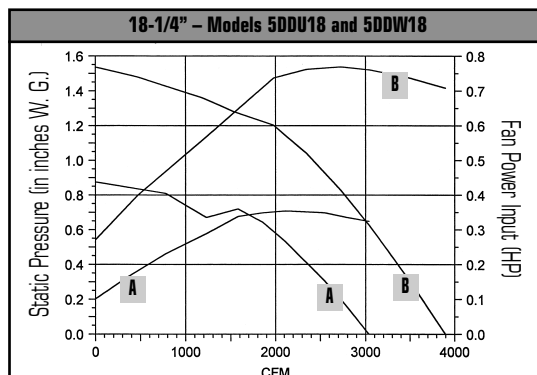

A = 5DDU18CA, 5DDW18CA, 858 RPM
B = 5DDU18EB, 5DDW18EB, 1111 RPM

Performance certified is for installation type A: free inlet, free outlet. Performance rating includes the effects of bird screen.

Centrifugal Ventilators

Belt-Drive Upblast Centrifugal Roof & Wall Ventilators

Belt-drive upblast ventilators are designed for roof or wall mounted exhaust for commercial or industrial buildings.

Agency Listings

- All ventilators are UL Standard 705 listed
- All ventilators are UL Standard 762 (Subject YZHW) listed when sold complete with motor and variable pitch drive
- Complies with NFPA 96 application requirements
- All motor and drive packages comply with the minimum efficiency levels of EPA '92. Affected motors bear the  seal
- Ventilators are CSA listed according to Standard C22.2 No. 113-M1984 (Fans & Ventilators)

Features and Specifications

- Upblast discharge design
- Spun aluminum construction with steel support braces
- Weather resistant aluminum windband, motor enclosure, and cover
- Ball bearing motors and variable pitch drives are packed separately when ordered with ventilators
- Backward inclined aluminum fan wheel
- Externally cooled motor compartment
- Inlet temperatures up to 300°F
- Models 5BDU10 – 5BDU24 only, are wall mount capable
- Models 5BDU13 – 5BDU36 available in hazardous location configuration
- Permanently lubricated ball bearings
- Regreaseable, pillow-block bearings factory installed on models 5BDU30 and 5BDU36 only

- Motor and wheel are easily detachable without removing ventilator from curb
- Junction box mounted in motor compartment
- Uni-Mount motor structure
- A continuous venturi to windband weld virtually eliminates grease leakage
- Fully rolled windband bead for added strength, stability and ease of transport
- Welded curb cap corners eliminate water entry into ducts or building

Accessories (available separately)

- For more information, see Power Roof Ventilator Accessories (NEMA 1, NEMA 3R and NEMA 4 disconnect switches.)
- Fixed ventilated mounting curbs.
- Grease collector box.
- Hinge kit.
- Bird screen to protect discharge and ensure safe, obstruction-free operation.
- Backdraft dampers.
- **WARNING: Do not use a damper in any kitchen exhaust application.**
- Non kitchen applications may use a non ventilated curb.
- 13" diameter and larger are available in explosion-proof construction with hazardous location motors (only available in 1/2 HP motors and larger)
- Note: Motors included in hazardous location configurations are UL listed for Class I, Division I, Group D, and Class II, Division I, Groups F & G. Ventilators meet AMCA Type C classification for spark resistant construction. Consult with your local ventilation or fire inspector for all code requirements.

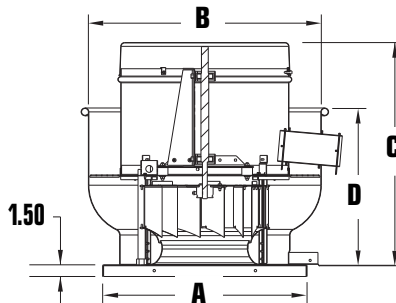

Fantech, Inc. and Systemair Mfg. Inc. certify that the Belt-Drive Upblast Centrifugal Roof & Wall Ventilators shown herein are licensed to bear the AMCA Seal. The ratings shown are based on tests and procedures performed in accordance with AMCA Publication 211 and AMCA Publication 311 and comply with the requirements of the AMCA Certified Ratings Program.

Model No.	Wheel Diameter (In.)	Wheel Bore Size (In.)	Pulley Bore Size (In.)	Dimensions (In.)				Gauge Thickness (In.)				Max Total Ship Wt. (lbs.)	Recommended Roof Opening (In.)	Optional Accessories	
				A	B	C	D	Windband	Venturi	Motor Enclosure	Hood			Roof Mount ² Backdraft Damper Model No.	Vented Roof Curb Model No.
5BDU10	10-1/2	1/2	7/8	19	23-7/8	23-3/8	16-7/8	0.063	0.05	0.04	0.05	66	14-1/2 x 14-1/2	5ACC12RD	5ACC17VC
5BDU12	12-1/4	1/2	7/8	22	26-1/2	24-1/4	17-3/4	0.063	0.063	0.04	.05	76	17-1/2 x 17-1/2	5ACC15RD	5ACC20VC
5BDU13	13-1/2	5/8	7/8	22	27-7/8	24-5/8	18-1/2	0.063	0.063	0.04	0.04	91	17-1/2 x 17-1/2	5ACC15RD	5ACC20VC
5BDU15	15	5/8	7/8	26	29-7/8	27-3/8	19-3/8	0.063	0.08	0.04	0.05	120	21-1/2 x 21-1/2	5ACC19RD	5ACC24VC
5BDU16	16-1/2	5/8	7/8	26	31-3/4	27-3/4	20-1/8	0.063	0.063	0.04	0.05	121	21-1/2 x 21-1/2	5ACC19RD	5ACC24VC
5BDU18	18-1/4	5/8	7/8	30	34	29-7/8	21-1/8	0.063	0.08	0.04	0.04	151	25-1/2 x 25-1/2	5ACC23RD	5ACC28VC
5BDU20	20	7/8	7/8	30	36-1/2	30-1/4	22	0.08	0.063	0.04	0.05	153	25-1/2 x 25-1/2	5ACC23RD	5ACC28VC
5BDU24	24-1/2	7/8	7/8	34	42-3/8	33	24-1/2	0.08	0.063	0.04	0.05	180	29-1/2 x 29-1/2	5ACC27RD	5ACC32VC
5BDU30	30	1	1	42	49-1/2	38-3/4	27-1/2	0.125	0.08	0.063	0.04	490	37-1/2 x 37-1/2	5ACC35RD	5ACC40VC
5BDU36	36-1/2	1-3/16	1-3/16	46	58-1/6	42-7/8	31-1/8	0.125	0.09	0.063	0.04	569	43-1/2 x 43-1/2	5ACC39RD	5ACC44VC

MOTOR SELECTION GUIDE

Dia. (In.)	HP	Open Dripproof		Hazardous Location	
		Single Phase	Three Phase	Single Phase	Three Phase
10	1/6	AB	—	—	—
10-15	1/4	BB	—	—	—
12-24	1/3	CB	—	—	—
13-30	1/2	DB	DX	DL	DM
15-36	3/4	EB	EX	EL	EM

Dia. (In.)	HP	Open Dripproof		Hazardous Location	
		Single Phase	Three Phase	Single Phase	Three Phase
15-36	1	FB	FX	FL	FM
18-36	1-1/2	GB	GX	GL	GM
18-36	2	—	HX	—	HM
30-36	3	—	JX	—	JM
30-36	5	—	KX	—	KM

B = 115/230/60/1 Open Dripproof
 X = 208-220/440/60/3 Open Dripproof
 L = 115/230/60/1 Hazardous Location
 M = 230/460/60/3 Hazardous Location
 For fan with motor and drive package, add the two-digit motor HP, phase and enclosure code.
 Example: 5BDU10AB

² Not for use with any kitchen applications.

Centrifugal Ventilators

Belt-Drive Upblast Centrifugal Roof & Wall Ventilators

5BDU10

HP	Motor Options	RPM	TS (FPM)	0.0" SP	0.125" SP	0.250" SP	0.375" SP	0.500" SP	0.625" SP	0.750" SP	0.875" SP	1.00" SP	1.25" SP	1.50" SP	1.75" SP		
				CFM	CFM	CFM	CFM	CFM	CFM	CFM	CFM	CFM	CFM	CFM	CFM	CFM	CFM
				Sones†	BHP#	Sones†	BHP#	Sones†	BHP#	Sones†	BHP#	Sones†	BHP#	Sones†	BHP#	Sones†	BHP#
1/6	AB	1452	3992	941	885	824	751	668	560								
				10.0	0.11	9.5	0.12	8.9	0.12	8.1	0.12	7.6	0.13	7.4	0.12		
		1506	4139	976	922	864	796	719	625								
				10.5	0.12	10.3	0.13	10.0	0.13	9.0	0.14	8.5	0.14	7.9	0.14		
		1589	4368	1030	981	925	860	791	712	608	412						
				10.9	0.15	11.2	0.15	10.9	0.16	10.0	0.16	9.3	0.16	9.0	0.16	8.5	0.16
1/4	BB	1674	4602	1085	1037	986	929	865	795	712							
				12.0	0.17	11.8	0.18	11.5	0.18	10.9	0.19	10.2	0.19	10.0	0.19	9.3	0.19
		1736	4772	1125	1079	1030	977	917	851	777	685						
				13.1	0.19	12.8	0.20	12.4	0.20	12.1	0.21	11.4	0.21	10.8	0.21	10.3	0.21
		1819	5000	1179	1138	1089	1037	981	922	855	776	679					
				15.1	0.22	14.7	0.23	14.3	0.23	13.5	0.24	13.1	0.24	12.8	0.25	12.0	0.25

5BDU12

HP	Motor Options	RPM	TS (FPM)	0.0" SP	0.125" SP	0.250" SP	0.375" SP	0.500" SP	0.625" SP	0.750" SP	0.875" SP	1.00" SP	1.25" SP	1.50" SP	1.75" SP				
				CFM	CFM	CFM	CFM	CFM	CFM	CFM	CFM	CFM	CFM	CFM	CFM	CFM	CFM		
				Sones†	BHP#	Sones†	BHP#	Sones†	BHP#	Sones†	BHP#	Sones†	BHP#	Sones†	BHP#	Sones†	BHP#	Sones†	BHP#
1/4	BB	1345	4312	1314	1250	1183	1108	1023	927	820									
				14.2	0.18	14.0	0.18	13.7	0.19	13.4	0.20	12.9	0.20	12.6	0.20	11.9	0.20		
		1394	4472	1362	1300	1236	1166	1086	996	898	767								
				12.4	0.20	11.8	0.21	11.5	0.21	11.3	0.22	10.7	0.22	10.1	0.23	9.6	0.23	9.1	0.22
		1423	4564	1390	1328	1266	1195	1121	1034	939	831								
				12.5	0.21	12.3	0.22	11.7	0.23	11.3	0.23	10.8	0.24	10.2	0.24	9.7	0.24	9.5	0.24
1/3	CB	1480	4746	1446	1388	1328	1264	1193	1113	1025	930	792							
				12.9	0.24	12.6	0.24	12.4	0.25	12.0	0.26	11.4	0.27	10.9	0.27	10.1	0.27	10.1	0.27
		1535	4922	1499	1444	1386	1325	1259	1185	1102	1014	915							
				13.1	0.26	12.8	0.27	12.7	0.28	12.4	0.29	12.1	0.29	11.4	0.30	10.8	0.30	10.3	0.30
		1566	5022	1530	1473	1417	1358	1290	1223	1142	1060	961							
				13.1	0.28	13.1	0.29	12.7	0.30	12.7	0.31	12.3	0.31	11.7	0.32	11.0	0.32	10.3	0.32

Performance certified is for installation type A: free inlet, free outlet. Performance rating includes the effects of bird screen.

Power rating (BHP) does not include transmission losses.

† The sound ratings shown are loudness values in fan sones at 5 ft. (1.5m) in a hemispherical free field calculated per AMCA standard 301. Values shown are for installation type A, free inlet hemispherical sone levels.

Centrifugal Ventilators

Belt-Drive Upblast Centrifugal Roof & Wall Ventilators

5BDU13

HP	Motor Options	RPM	TS (FPM)	0.0" SP	0.125" SP	0.250" SP	0.375" SP	0.500" SP	0.625" SP	0.750" SP	0.875" SP	1.00" SP	1.25" SP	1.50" SP	1.75" SP			
				CFM	CFM	CFM	CFM	CFM	CFM	CFM	CFM	CFM	CFM	CFM	CFM	CFM	CFM	CFM
				Sones†	BHP#	Sones†	BHP#	Sones†	BHP#	Sones†	BHP#	Sones†	BHP#	Sones†	BHP#	Sones†	BHP#	Sones†
1/4	BB	1124	3974	1608	1509	1406	1296	1174	1025									
				11.1	0.17	10.6	0.18	10.1	0.19	9.3	0.20	8.7	0.20	8.0	0.20			
		1166	4121	1668	1573	1474	1370	1256	1124									
				11.6	0.19	11.2	0.20	11.0	0.21	10.3	0.22	9.4	0.22	8.9	0.22			
		1210	4287	1730	1638	1543	1443	1334	1216	1061								
				12.2	0.21	12.0	0.22	11.5	0.23	11.0	0.24	10.3	0.25	9.4	0.25	8.5	0.25	
1/3	CB	1256	4438	1797	1708	1618	1523	1422	1311	1182								
				13.5	0.23	12.7	0.25	12.2	0.26	11.7	0.27	11.4	0.27	10.5	0.28	9.5	0.28	
		1295	4576	1852	1767	1679	1588	1492	1387	1270								
				13.8	0.26	13.2	0.27	13.1	0.28	12.4	0.29	11.8	0.30	11.2	0.30	10.5	0.30	
		1330	4718	1902	1818	1734	1643	1552	1449	1343	1201							
				14.1	0.28	13.7	0.29	13.1	0.30	12.9	0.31	12.5	0.32	11.7	0.33	11.1	0.33	10.2
1/2	DB	1397	4937	1998	1919	1838	1755	1668	1577	1478	1368	1233						
				15.2	0.32	15.1	0.33	14.6	0.35	14.3	0.36	13.5	0.37	12.8	0.38	12.1	0.38	10.9
	1440	5091	2060	1983	1905	1825	1741	1654	1560	1458	1341							
			16.1	0.35	15.7	0.37	15.5	0.38	14.7	0.391	4.4	0.40	13.8	0.41	13.0	0.42	12.6	0.42
	1530	5400	2188	2115	2042	1966	1888	1808	1723	1732	1538							
			17.3	0.42	17.0	0.44	16.3	0.45	16.2	0.46	15.4	0.48	15.4	0.49	15.1	0.50	14.2	0.50

5BDU15

HP	Motor Options	RPM	TS (FPM)	0.0" SP	0.125" SP	0.250" SP	0.375" SP	0.500" SP	0.625" SP	0.750" SP	0.875" SP	1.00" SP	1.25" SP	1.50" SP	1.75" SP			
				CFM	CFM	CFM	CFM	CFM	CFM	CFM	CFM	CFM	CFM	CFM	CFM	CFM	CFM	
				Sones†	BHP#	Sones†	BHP#	Sones†	BHP#	Sones†	BHP#	Sones†	BHP#	Sones†	BHP#	Sones†	BHP#	Sones†
1/4	BB	944	3707	1782	1664	1535	1387	1203	529									
				10.6	0.17	10.6	0.18	10.2	0.18	9.9	0.19	9.2	0.19	8.0	0.12			
		979	3844	1848	1735	1612	1473	1308	1055									
				11.2	0.19	10.9	0.20	10.8	0.21	10.1	0.21	9.8	0.21	9.1	0.20			
		1033	4057	1950	1840	1727	1599	1450	1258	568								
				11.8	0.22	11.5	0.23	11.5	0.24	10.8	0.25	10.5	0.25	9.9	0.25	8.6	0.16	
1/3	CB	1068	4194	2016	1912	1803	1682	1546	1384	1133								
				12.3	0.24	11.9	0.25	11.7	0.26	11.4	0.27	10.8	0.27	10.5	0.27	9.9	0.26	
		1093	4291	2063	1962	1856	1739	1609	1458	1248								
				12.4	0.26	12.1	0.27	11.8	0.28	11.7	0.29	11.3	0.29	10.8	0.29	10.1	0.29	
		1136	4461	2145	2045	1945	1832	1713	1571	1393	1070							
				13.1	0.29	12.8	0.30	12.5	0.31	12.3	0.32	12.0	0.33	11.4	0.33	10.8	0.33	10.2

Performance certified is for installation type A: free inlet, free outlet. Performance rating includes the effects of bird screen.

Power rating (BHP) does not include transmission losses.

† The sound ratings shown are loudness values in fan sones at 5 ft. (1.5m) in a hemispherical free field calculated per AMCA standard 301. Values shown are for installation type A, free inlet hemispherical sone levels.

Centrifugal Ventilators

Belt-Drive Upblast Centrifugal Roof & Wall Ventilators

5BDU15 *cont.*

HP	Motor Options	RPM	TS (FPM)	0.0" SP		0.125" SP		0.250" SP		0.375" SP		0.500" SP		0.625" SP		0.750" SP		0.875" SP		1.00" SP		1.25" SP		1.50" SP		1.75" SP					
				CFM		CFM		CFM		CFM		CFM		CFM		CFM		CFM		CFM		CFM		CFM		CFM		CFM		CFM	
				Sones†	BHP#	Sones†	BHP#	Sones†	BHP#	Sones†	BHP#	Sones†	BHP#	Sones†	BHP#	Sones†	BHP#	Sones†	BHP#	Sones†	BHP#	Sones†	BHP#	Sones†	BHP#	Sones†	BHP#	Sones†	BHP#	Sones†	BHP#
1/2	DB	1185	4652	2237		2144		2047		1944		1831		1706		1561		1366		587											
				13.8	0.33	13.6	0.34	13.3	0.35	13.1	0.36	12.4	0.37	12.1	0.38	11.9	0.37	11.3	0.37	9.7	0.23										
	DX	1222	4798	2307		2217		2124		2024		1916		1799		1667		1503		1241											
				14.5	0.36	14.2	0.38	13.6	0.39	13.5	0.40	13.2	0.41	12.9	0.41	12.3	0.41	12.0	0.41	11.4	0.39										
DL	1301	5109	2456		2369		2282		2193		2091		1989		1868		1745		1572												
			15.4	0.44	15.4	0.45	15.1	0.47	14.9	0.48	14.4	0.49	14.1	0.49	13.8	0.50	13.2	0.50	12.9	0.49											
3/4	EB	1353	5314	2554		2473		2390		2303		2211		2112		2006		1891		1757		905									
				16.2	0.49	16.2	0.51	16.1	0.52	15.5	0.53	15.2	0.54	15.0	0.55	14.9	0.56	14.2	0.56	14.0	0.56	11.6	0.39								
	EX	1403	5510	2649		2570		2490		2408		2320		2227		2127		2021		1902		1578									
				17.10	.55	16.7	0.56	16.5	0.58	16.5	0.59	16.3	0.60	15.7	0.61	15.4	0.62	15.2	0.62	14.9	0.62	13.5	0.60								
EL	1489	5847	2811		2735		2659		2582		2503		2414		2325		2231		2123		1875		1412								
			18.1	0.66	17.9	0.67	17.8	0.69	17.7	0.70	17.1	0.72	16.9	0.73	16.5	0.74	16.4	0.74	15.7	0.74	15.0	0.74	13.9	0.68							
1	FB	1542	6056	2911		2840		2767		2693		2617		2536		2451		2361		2266		2051		1750							
				18.7	0.73	18.6	0.74	18.2	0.76	18.1	0.78	18.0	0.79	17.9	0.80	17.1	0.81	17.0	0.82	16.7	0.83	15.8	0.82	15.2	0.80						
	FX	1590	6243	3002		2932		2862		2791		2717		2640		2559		2474		2384		2186		1933		971					
				19.0	0.80	19.0	0.81	18.9	0.83	18.7	0.85	18.5	0.86	18.2	0.88	18.1	0.89	17.5	0.90	17.3	0.90	17.0	0.91	16.1	0.89	14.4	0.61				
FL	1639	6436	3094		3025		2956		2886		2817		2743		2662		2582		2501		2307		2081		1727						
			20	0.87	20	0.89	20	0.91	19.2	0.93	19.1	0.94	18.9	0.96	18.8	0.97	18.4	0.98	18.2	0.97	17.4	0.99	16.7	0.98	16.4	0.95					
FM																															

5BDU16

HP	Motor Options	RPM	TS (FPM)	0.0" SP		0.125" SP		0.250" SP		0.375" SP		0.500" SP		0.625" SP		0.750" SP		0.875" SP		1.00" SP		1.25" SP		1.50" SP		1.75" SP					
				CFM		CFM		CFM		CFM		CFM		CFM		CFM		CFM		CFM		CFM		CFM		CFM		CFM		CFM	
				Sones†	BHP#	Sones†	BHP#	Sones†	BHP#	Sones†	BHP#	Sones†	BHP#	Sones†	BHP#	Sones†	BHP#	Sones†	BHP#	Sones†	BHP#	Sones†	BHP#	Sones†	BHP#	Sones†	BHP#	Sones†	BHP#	Sones†	BHP#
1/3	CB	865	3736	2270		2114		1948		1771		1568																			
				10.4	0.21	9.6	0.22	9.1	0.23	8.6	0.24	7.8	0.24																		
		897	3875	2354		2203		2045		1875		1693		1419																	
11.0	0.24			10.3	0.25	9.9	0.26	9.1	0.27	8.6	0.27	7.9	0.26																		
960	4156	2520		2377		2232		2076		1910		1702		1390																	
		12.4	0.29	12.1	0.30	11.7	0.31	10.9	0.32	10.6	0.33	9.6	0.33	8.8	0.31																
1/2	DB	1004	4335	2635		2501		2362		2215		2062		1897		1670															
				12.9	0.34	12.2	0.35	11.8	0.36	11.4	0.37	10.8	0.37	10.2	0.38	9.7	0.37														
	DX	1041	4496	2732		2603		2470		2329		2183		2030		1843															
				13.6	0.37	13.3	0.38	12.5	0.39	12.1	0.40	11.5	0.41	10.7	0.42	10.3	0.42														
DL	1100	4756	2887		2762		2637		2507		2370		2226		2077		1847		1529												
			15.7	0.44	14.7	0.45	14.2	0.46	13.5	0.47	12.8	0.48	12.0	0.49	11.8	0.50	11.4	0.49	9.8	0.47											

Performance certified is for installation type A: free inlet, free outlet. Performance rating includes the effects of bird screen.

Power rating (BHP) does not include transmission losses.

† The sound ratings shown are loudness values in fan sones at 5 ft. (1.5m) in a hemispherical free field calculated per AMCA standard 301. Values shown are for installation type A, free inlet hemispherical sone levels.

Centrifugal Ventilators

Belt-Drive Upblast Centrifugal Roof & Wall Ventilators

5BDU16 cont.

HP	Motor Options	RPM	TS (FPM)	0.0" SP		0.125" SP		0.250" SP		0.375" SP		0.500" SP		0.625" SP		0.750" SP		0.875" SP		1.00" SP		1.25" SP		1.50" SP		1.75" SP					
				CFM		CFM		CFM		CFM		CFM		CFM		CFM		CFM		CFM		CFM		CFM		CFM		CFM		CFM	
				Sones†	BHP#	Sones†	BHP#	Sones†	BHP#	Sones†	BHP#	Sones†	BHP#	Sones†	BHP#	Sones†	BHP#	Sones†	BHP#	Sones†	BHP#	Sones†	BHP#	Sones†	BHP#	Sones†	BHP#	Sones†	BHP#	Sones†	BHP#
3/4	EB	1147	4956	3010		2893		2773		2649		2519		2385		2247		2085		1864											
				15.8	0.50	15.5	0.51	14.5	0.52	14.3	0.53	13.6	0.55	12.8	0.56	12.5	0.56	11.8	0.56	11.0	0.55										
	EX	1171	5057	3073		2958		2841		2721		2594		2463		2329		2180		1986											
				16.7	0.53	15.7	0.54	15.3	0.56	14.6	0.57	14.3	0.58	13.6	0.59	12.8	0.60	12.4	0.60	11.7	0.59										
	EM	1260	5447	3307		3198		3089		2980		2864		2744		2623		2492		2360											
				18.2	0.66	17.7	0.68	17.4	0.69	17.2	0.70	16.2	0.71	15.7	0.72	15.3	0.74	14.9	0.74	14.2	0.75										
1	FB	1293	5584	3394		3290		3184		3077		2965		2850		2731		2611		2483											
				19.1	0.72	18.6	0.73	17.9	0.74	17.3	0.76	17.2	0.77	16.3	0.78	15.6	0.79	15.2	0.80	15.0	0.81										
	FX	1333	5757	3499		3398		3296		3192		3085		2973		2859		2744		2624		2331									
				19.6	0.79	19.2	0.80	18.8	0.81	18.4	0.83	17.8	0.84	17.4	0.85	16.6	0.86	16.3	0.87	15.9	0.88	15.5	0.88								
	FL	1400	5996	3674		3576		3478		3380		3282		3175		3068		2961		2844											
				21	0.91	21	0.92	21	0.94	19.8	0.95	19.6	0.97	19.6	0.98	18.6	0.99	18.4	1.0	17.4	1.02										
FM	1400	5996	3674		3576		3478		3380		3282		3175		3068		2961		2844												
			21	0.91	21	0.92	21	0.94	19.8	0.95	19.6	0.97	19.6	0.98	18.6	0.99	18.4	1.0	17.4	1.02											

5BDU18

HP	Motor Options	RPM	TS (FPM)	0.0" SP		0.125" SP		0.250" SP		0.375" SP		0.500" SP		0.625" SP		0.750" SP		0.875" SP		1.00" SP		1.25" SP		1.50" SP		1.75" SP					
				CFM		CFM		CFM		CFM		CFM		CFM		CFM		CFM		CFM		CFM		CFM		CFM		CFM		CFM	
				Sones†	BHP#	Sones†	BHP#	Sones†	BHP#	Sones†	BHP#	Sones†	BHP#	Sones†	BHP#	Sones†	BHP#	Sones†	BHP#	Sones†	BHP#	Sones†	BHP#	Sones†	BHP#	Sones†	BHP#	Sones†	BHP#	Sones†	BHP#
1/3	CB	730	3489	2489		2307		2098		1854		1547																			
				8.9	0.20	8.5	0.21	8.1	0.22	7.8	0.23	7.4	0.23																		
		757	3618	2581		2406		2208		1978		1710																			
				9.2	0.22	8.9	0.24	8.6	0.25	8.2	0.25	7.8	0.25																		
		811	3875	2765		2600		2419		2217		1987		1676																	
				10.1	0.27	9.8	0.29	9.6	0.30	9.2	0.31	8.6	0.31	8.4	0.31																
1/2	DB	855	4083	2916		2762		2596		2406		2197		1960																	
				10.5	0.32	10.4	0.34	10.2	0.35	9.8	0.36	9.1	0.37	8.8	0.37																
		886	4235	3021		2873		2715		2536		2338		2121																	
				11.1	0.36	10.8	0.37	10.6	0.39	10.2	0.40	9.6	0.41	9.3	0.41																
		928	4434	3164		3020		2873		2701		2523		2321		2070		1589													
				11.7	0.41	11.5	0.43	11.6	0.44	11.2	0.46	10.5	0.47	10.1	0.47	9.8	0.47	9.0	0.43												
3/4	EB	992	4738	3383		3251		3114		2964		2798		2620		2429		2209													
				13.0	0.50	13.1	0.52	12.8	0.54	12.4	0.55	12.1	0.56	11.5	0.57	11.0	0.57	10.8	0.57												
		1021	4877	3482		3354		3221		3078		2920		2749		2568		2368													
				13.8	0.55	13.8	0.56	13.5	0.58	13.3	0.60	12.8	0.61	12.3	0.62	11.6	0.63	11.4	0.62												
		1062	5074	3621		3496		3368		3233		3080		2926		2753		2577		2335											
				14.8	0.61	14.5	0.63	14.3	0.65	14.1	0.67	13.9	0.69	13.3	0.70	12.8	0.70	12.6	0.70	11.9	0.70										

Performance certified is for installation type A: free inlet, free outlet. Performance rating includes the effects of bird screen.

Power rating (BHP) does not include transmission losses.

† The sound ratings shown are loudness values in fan sones at 5 ft. (1.5m) in a hemispherical free field calculated per AMCA standard 301. Values shown are for installation type A, free inlet hemispherical sone levels.

Centrifugal Ventilators

Belt-Drive Upblast Centrifugal Roof & Wall Ventilators

5BDU18 cont.

HP	Motor Options	RPM	TS (FPM)	0.0" SP	0.125" SP	0.250" SP	0.375" SP	0.500" SP	0.625" SP	0.750" SP	0.875" SP	1.00" SP	1.25" SP	1.50" SP	1.75" SP												
				CFM		CFM		CFM		CFM		CFM		CFM		CFM		CFM									
				Sones†	BHP#	Sones†	BHP#	Sones†	BHP#	Sones†	BHP#	Sones†	BHP#	Sones†	BHP#	Sones†	BHP#	Sones†	BHP#								
1	FB	1100	5256	3751		3632		3511		3382		3242		3090		2930		2761		2577							
				15.9	0.68	15.4	0.70	15.3	0.72	15.6	0.74	14.8	0.76	14.2	0.77	14.1	0.78	13.3	0.78	13.1	0.78						
	FX	1134	5448	3867		3752		3634		3511		3377		3233		3080		2920		2749							
				16.4	0.75	16.3	0.77	16.6	0.79	16.4	0.81	15.7	0.83	15.5	0.84	14.9	0.85	14.6	0.86	14.0	0.86						
FL	1169	5585	3986		3873		3756		3640		3508		3368		3229		3074		2914		2502						
			17.6	0.82	17.3	0.84	17.5	0.86	17.1	0.88	16.9	0.90	16.3	0.92	16.2	0.93	15.4	0.94	15.4	0.94	13.9	0.93					
1-1/2	GB	1197	5719	4082		3973		3862		3747		3624		3492		3351		3204		3050		2704					
				18.3	0.88	18.0	0.90	17.7	0.92	18.1	0.94	18.1	0.96	16.9	0.98	16.3	0.99	16.3	1.00	15.5	1.01	14.7	1.01				
	GX	1234	5897	4208		4102		3995		3884		3767		3641		3507		3366		3220		2902					
				18.5	0.97	18.8	0.99	18.7	1.01	18.4	1.03	18.1	1.05	18.1	1.07	17.1	1.08	16.5	1.09	16.3	1.10	15.5	1.10				
GL	1338	6393	4563		4465		4363		4261		4159		4045		3923		3800		3678		3402		3077		2683		
			21	1.23	21	1.25	20	1.28	20	1.30	20	1.32	19.5	1.35	19.1	1.36	18.5	1.38	18.2	1.39	17.3	1.41	16.5	1.41	15.8	1.38	
GM	1473	7038	5023		4935		4842		4750		4657		4564		4459		4348		4238		4015		3761		3482		
			25	1.64	24	1.67	24	1.70	23	1.72	23	1.75	22	1.77	22	1.79	21	1.82	21	1.83	19.5	1.86	18.7	1.88	17.9	1.88	
2	HX	1360	6497	4638		4542		4445		4346		4244		4136		4022		3901		3775		3511		3222			
				22	1.29	21	1.32	21	1.34	21	1.36	21	1.39	20	1.41	19.5	1.43	19.1	1.45	18.5	1.46	17.4	1.48	16.7	1.48		
	HM	1388	6630	4733		4639		4544		4448		4348		4243		4133		4017		3894		3638		3362		3036	
				22	1.37	22	1.40	21	1.42	21	1.45	21	1.47	21	1.49	20	1.51	19.5	1.53	18.6	1.55	17.7	1.57	17.4	1.57	16.8	1.56
HM	1473	7038	5023		4935		4842		4750		4657		4564		4459		4348		4238		4015		3761		3482		
			25	1.64	24	1.67	24	1.70	23	1.72	23	1.75	22	1.77	22	1.79	21	1.82	21	1.83	19.5	1.86	18.7	1.88	17.9	1.88	

5BDU20

HP	Motor Options	RPM	TS (FPM)	0.0" SP	0.125" SP	0.250" SP	0.375" SP	0.500" SP	0.625" SP	0.750" SP	0.875" SP	1.00" SP	1.25" SP	1.50" SP	1.75" SP				
				CFM		CFM		CFM		CFM		CFM		CFM		CFM		CFM	
				Sones†	BHP#	Sones†	BHP#	Sones†	BHP#	Sones†	BHP#	Sones†	BHP#	Sones†	BHP#	Sones†	BHP#	Sones†	BHP#
1/3	CB	634	3319	2946		2691		2409		2066		796							
				10.8	0.22	9.8	0.23	9.3	0.25	9.0	0.25	8.3	0.15						
		657	3442	3053		2808		2539		2223		1750							
11.5	0.24			10.3	0.26	9.8	0.27	9.6	0.28	9.0	0.27								
695	3660	3329		2996		2742		2456		2094									
		12.9	0.29	12.2	0.30	11.8	0.32	11.4	0.33	11.2	0.32								
1/2	DB	764	4002	3550		3341		3120		2879		2603		2250					
				12.6	0.38	12.1	0.40	11.8	0.42	11.6	0.43	11.4	0.44	10.8	0.43				
	DX	787	4119	3657		3454		3241		3010		2751		2437		1197			
				13.0	0.42	12.8	0.44	12.4	0.46	12.2	0.47	12.0	0.47	11.4	0.47	10.5	0.31		
DL	800	4189	3718		3515		3304		3078		2820		2527		2005				
			14.0	0.44	13.6	0.46	13.1	0.48	12.6	0.49	12.2	0.50	12.3	0.50	12.0	0.47			
DM	800	4189	3718		3515		3304		3078		2820		2527		2005				
			14.0	0.44	13.6	0.46	13.1	0.48	12.6	0.49	12.2	0.50	12.3	0.50	12.0	0.47			

Performance certified is for installation type A: free inlet, free outlet. Performance rating includes the effects of bird screen.

Power rating (BHP) does not include transmission losses.

† The sound ratings shown are loudness values in fan sones at 5 ft. (1.5m) in a hemispherical free field calculated per AMCA standard 301. Values shown are for installation type A, free inlet hemispherical sone levels.

Centrifugal Ventilators

Belt-Drive Upblast Centrifugal Roof & Wall Ventilators

5BDU20 cont.

HP	Motor Options	RPM	TS (FPM)	0.0" SP		0.125" SP		0.250" SP		0.375" SP		0.500" SP		0.625" SP		0.750" SP		0.875" SP		1.00" SP		1.25" SP		1.50" SP		1.75" SP					
				CFM		CFM		CFM		CFM		CFM		CFM		CFM		CFM		CFM		CFM		CFM		CFM		CFM		CFM	
				Sones†	BHP#	Sones†	BHP#	Sones†	BHP#	Sones†	BHP#	Sones†	BHP#	Sones†	BHP#	Sones†	BHP#	Sones†	BHP#	Sones†	BHP#	Sones†	BHP#	Sones†	BHP#	Sones†	BHP#	Sones†	BHP#	Sones†	BHP#
3/4	EB	854	4471	3969	3781	3588	3383	3159	2908	2606	2046																				
				13.9	0.53	13.8	0.55	13.6	0.58	13.5	0.59	13.30	.60	13.0	0.61	12.8	0.60	12.2	0.56												
	EX	879	4602	4085	3903	3716	3519	3306	3070	2796	2427																				
				14.4	0.58	14.2	0.60	14.1	0.62	14.1	0.64	13.9	0.65	13.8	0.66	13.3	0.66	12.9	0.64												
EL	915	4796	4252	4075	3898	3703	3505	3282	3039	2734	2175																				
			15.7	0.65	15.3	0.68	15.1	0.70	14.5	0.72	14.3	0.74	13.7	0.75	13.9	0.75	13.4	0.74	12.8	0.68											
1	FB	960	5028	4461	4295	4125	3949	3763	3563	3344	3096	2790																			
				15.8	0.75	15.8	0.78	15.8	0.81	15.8	0.83	15.4	0.84	15.4	0.86	15.4	0.86	14.9	0.86	15.0	0.85										
	FX	989	5176	4596	4435	4271	4101	3922	3732	3526	3298	3032																			
				16.5	0.82	16.5	0.85	16.5	0.88	16.4	0.90	16.4	0.92	16.3	0.93	16.1	0.94	15.8	0.95	15.3	0.94										
FL	1010	5278	4693	4533	4373	4206	4026	3846	3643	3423	3181	1422																			
			17.6	0.88	17.2	0.91	17.1	0.93	16.6	0.96	16.2	0.98	15.5	0.99	15.5	1.00	14.9	1.00	14.9	1.00	14.8	0.63									
1-1/2	GB	1081	5660	5023	4876	4727	4574	4415	4249	4074	3887	3684	3187																		
				18.8	1.08	18.8	1.11	18.7	1.14	18.6	1.16	18.5	1.18	18.2	1.20	17.8	1.22	17.7	1.23	17.7	1.23	17.5	1.22								
	GX	1113	5628	5172	5029	4884	4737	4584	4425	4257	4080	3890	3446																		
				19.7	1.17	19.5	1.21	19.5	1.24	19.4	1.26	19.3	1.29	18.8	1.31	18.8	1.32	18.7	1.34	18.7	1.34	17.9	1.34								
GL	1155	6042	5367	5227	5086	4947	4797	4640	4483	4325	4136	3750																			
			22	1.31	21	1.34	21	1.38	21	1.41	20	1.43	19.8	1.46	19.2	1.47	18.7	1.49	18.4	1.50	17.7	1.50									
2	HX	1224	6408	5688	5558	5427	5294	5158	5018	4873	4722	4563	4219	3811	3207																
				23	1.56	23	1.60	23	1.63	22	1.66	22	1.69	22	1.72	22	1.74	21	1.76	21	1.77	21	1.79	20	1.78	19.6	1.71				
	HM	1256	6576	5837	5710	5582	5453	5321	5186	5046	4900	4749	4423	4047	3562																
				23	1.69	23	1.72	23	1.76	23	1.79	23	1.82	23	1.85	23	1.87	22	1.89	23	1.91	22	1.93	22	1.93	21	1.89				
HM	1270	6650	5902	5774	5647	5519	5391	5252	5108	4966	4823	4491																			
			25	1.75	25	1.78	24	1.82	24	1.85	24	1.88	23	1.91	23	1.93	23	1.95	23	1.97	21	2.00									

5BDU24

HP	Motor Options	RPM	TS (FPM)	0.0" SP		0.125" SP		0.250" SP		0.375" SP		0.500" SP		0.625" SP		0.750" SP		0.875" SP		1.00" SP		1.25" SP		1.50" SP		1.75" SP						
				CFM		CFM		CFM		CFM		CFM		CFM		CFM		CFM		CFM		CFM		CFM		CFM		CFM		CFM		
				Sones†	BHP#	Sones†	BHP#	Sones†	BHP#	Sones†	BHP#	Sones†	BHP#	Sones†	BHP#	Sones†	BHP#	Sones†	BHP#	Sones†	BHP#	Sones†	BHP#	Sones†	BHP#	Sones†	BHP#	Sones†	BHP#	Sones†	BHP#	
1/3	CB	453	2904	4036	3578	3015																										
				10.5	0.23	10.3	0.25	9.9	0.25																							
		470	3012	4188	3750	3218																										
				10.6	0.25	10.6	0.27	10.3	0.28																							
		495	3233	4410	3989	3503	2826																									
				10.6	0.29	10.4	0.32	10.0	0.33	9.8	0.32																					

Performance certified is for installation type A: free inlet, free outlet. Performance rating includes the effects of bird screen.

Power rating (BHP) does not include transmission losses.

† The sound ratings shown are loudness values in fan sones at 5 ft. (1.5m) in a hemispherical free field calculated per AMCA standard 301. Values shown are for installation type A, free inlet hemispherical sone levels.

Centrifugal Ventilators

Belt-Drive Upblast Centrifugal Roof & Wall Ventilators

5BDU24 cont.

HP	Motor Options	RPM	TS (FPM)	0.0" SP		0.125" SP		0.250" SP		0.375" SP		0.500" SP		0.625" SP		0.750" SP		0.875" SP		1.00" SP		1.25" SP		1.50" SP		1.75" SP					
				CFM		CFM		CFM		CFM		CFM		CFM		CFM		CFM		CFM		CFM		CFM		CFM		CFM		CFM	
				Sones†	BHP#	Sones†	BHP#	Sones†	BHP#	Sones†	BHP#	Sones†	BHP#	Sones†	BHP#	Sones†	BHP#	Sones†	BHP#	Sones†	BHP#	Sones†	BHP#	Sones†	BHP#	Sones†	BHP#	Sones†	BHP#	Sones†	BHP#
1/2	DB	523	3352	4660		4274		3819		3287																					
				11.4	0.35	11.1	0.37	11.0	0.39	10.5	0.39																				
	DX	542	3476	4829		4458		4027		3534																					
				12.0	0.39	11.7	0.41	11.6	0.43	10.9	0.43																				
DL	570	3701	5078		4727		4313		3866		3239																				
			11.9	0.45	11.9	0.48	11.3	0.50	11.0	0.51	10.4	0.50																			
3/4	EB	610	3911	5435		5109		4747		4336		3877		3184																	
				13.5	0.55	13.0	0.58	12.7	0.60	12.3	0.62	11.5	0.62	10.5	0.59																
	EX	632	4056	5631		5317		4972		4583		4157		3603																	
				13.8	0.61	13.3	0.64	13.4	0.67	12.7	0.68	12.1	0.69	11.0	0.68																
EL	650	4233	5791		5477		5126		4732		4324		3865																		
			14.4	0.67	14.4	0.70	13.7	0.73	13.7	0.74	13.4	0.75	11.4	0.75																	
1	FB	695	4457	6192		5909		5605		5267		4901		4502		3992															
				15.3	0.81	14.8	0.85	14.6	0.88	14.4	0.90	13.9	0.91	13.4	0.92	12.4	0.90														
	FX	715	4586	6370		6095		5803		5479		5127		4752		4303															
				16.2	0.88	15.5	0.92	15.4	0.95	15.3	0.97	14.7	0.99	13.8	1.00	12.7	1.00														
FL	720	4663	6415		6137		5842		5510		5180		4801		4310		3714														
			15.8	0.90	15.6	0.94	14.3	0.97	14.1	1.00	13.8	1.01	13.2	1.01	13.0	1.00	12.9	0.97													
1-1/2	GB	770	4936	6860		6605		6339		6048		5733		5399		5042		4614													
				17.3	1.11	16.4	1.14	16.4	1.18	16.7	1.21	16.3	1.23	15.4	1.24	14.5	1.25	13.8	1.24												
	GX	798	5118	7110		6864		6609		6333		6034		5716		5383		5009		4534											
				17.8	1.23	17.4	1.27	17.2	1.31	17.6	1.34	17.5	1.36	16.9	1.38	15.9	1.39	15.1	1.38	14.3	1.36										
GL	820	5337	7306		7062		6818		6535		6245		5954		5632		5296		4800												
			19.5	1.34	18.7	1.38	18.2	1.41	17.4	1.44	16.6	1.47	15.9	1.49	17.7	1.50	15.1	1.50	14.9	1.49											
2	HX	877	5626	7814		7591		7362		7120		6860		6583		6294		5993		5668		4797									
				20	1.63	19.6	1.68	19.4	1.72	19.7	1.75	21	1.79	20	1.81	19.5	1.83	19.2	1.84	17.7	1.84	16.9	1.79								
	HM	894	5732	7965		7746		7522		7286		7034		6766		6483		6192		5882		5100									
				20	1.73	20	1.77	20	1.81	20	1.85	21	1.89	22	1.91	20	1.93	20	1.95	19.1	1.95	18.2	1.91								
900	5875	8018		7796		7573		7334		7070		6806		6541		6251		5945		5101											
		24	1.76	23	1.81	22	1.85	22	1.89	21	1.92	19.7	1.95	19.0	1.97	18.7	1.98	18.1	1.99	18.4	1.95										

Performance certified is for installation type A: free inlet, free outlet. Performance rating includes the effects of bird screen.

Power rating (BHP) does not include transmission losses.

† The sound ratings shown are loudness values in fan sones at 5 ft. (1.5m) in a hemispherical free field calculated per AMCA standard 301. Values shown are for installation type A, free inlet hemispherical sone levels.

Centrifugal Ventilators

Belt-Drive Upblast Centrifugal Roof & Wall Ventilators

5BDU30

HP	Motor Options	RPM	TS (FPM)	0.0" SP		0.125" SP		0.250" SP		0.375" SP		0.500" SP		0.625" SP		0.750" SP		0.875" SP		1.00" SP		1.25" SP		1.50" SP		1.75" SP							
				CFM		CFM		CFM		CFM		CFM		CFM		CFM		CFM		CFM		CFM		CFM		CFM		CFM		CFM			
				Sones†	BHP#	Sones†	BHP#	Sones†	BHP#	Sones†	BHP#	Sones†	BHP#	Sones†	BHP#	Sones†	BHP#	Sones†	BHP#	Sones†	BHP#	Sones†	BHP#	Sones†	BHP#	Sones†	BHP#	Sones†	BHP#	Sones†	BHP#		
1/2	DB	365	2864	5522		4857		3998																									
				13.8	0.29	12.6	0.32	12.1	0.33																								
	DX	378	2970	5718		5082		4271		3065																							
				15.2	0.33	14.0	0.36	13.4	0.36	13.4	0.34																						
DL	412	3236	6232		5658		4955		4105																								
			16.1	0.42	15.1	0.46	14.5	0.47	14.2	0.47																							
3/4	EB	429	3370	6490		5941		5288		4510																							
				16.1	0.48	14.9	0.51	14.3	0.53	13.9	0.53																						
	EX	444	3487	6717		6188		5572		4832		3926																					
				15.7	0.53	15.0	0.57	14.7	0.59	14.1	0.59	14.1	0.57																				
EL	471	3699	7124		6622		6049		5391		4627																						
			17.6	0.63	15.7	0.67	14.6	0.70	14.6	0.70	13.9	0.70																					
1	FB	486	3817	7352		6873		6338		5704		5003		2785																			
				16.0	0.70	15.5	0.74	15.0	0.76	14.4	0.77	14.0	0.77	13.5	0.54																		
	FX	502	3945	7594		7132		6621		6022		5350		4580																			
				16.3	0.77	15.7	0.81	15.2	0.84	14.7	0.85	14.4	0.85	13.7	0.83																		
FL	519	4076	7850		7394		6901		6352		5709		4992																				
			19.1	0.85	15.7	0.89	15.2	0.93	14.6	0.94	14.6	0.94	14.0	0.93																			
1-1/2	GB	570	4476	8623		8218		7789		7308		6763		6170		5551																	
				17.1	1.12	16.4	1.17	16.2	1.21	15.6	1.24	14.9	1.25	14.5	1.24	14.3	1.23																
	GX	586	4602	8865		8471		8058		7597		7079		6509		5922		5143															
				17.1	1.22	16.8	1.27	16.5	1.31	15.9	1.34	15.4	1.35	14.8	1.35	14.3	1.35	14.1	1.31														
GL	594	4665	8985		8586		8188		7716		7233		6669		6072		5417																
			16.5	1.27	17.3	1.32	16.3	1.37	15.9	1.40	15.6	1.41	15.1	1.41	14.4	1.40	14.1	1.38															
2	HX	630	4948	9531		9166		8786		8375		7918		7415		6878		6330		5628													
				18.6	1.51	17.5	1.57	17.3	1.62	17.3	1.66	16.3	1.68	15.7	1.68	15.2	1.68	14.5	1.68	14.4	1.64												
	HM	645	5070	9758		9401		9032		8635		8197		7714		7195		6664		6077													
				19.3	1.63	18.4	1.68	17.9	1.73	17.9	1.77	16.9	1.80	16.2	1.80	15.7	1.80	14.9	1.80	14.6	1.78												
653	5129	9877		9515		9152		8755		8319		7867		7354		6824		6230															
		19.7	1.69	19.4	1.75	18.3	1.80	18.0	1.84	17.3	1.86	16.0	1.87	15.9	1.87	15.1	1.87	14.5	1.85														
3	JX	700	5501	10590		10261		9925		9571		9188		8772		8320		7841		7352		6131											
				20	2.08	21	2.14	20	2.20	19.8	2.25	19.4	2.28	17.9	2.30	17.4	2.31	16.9	2.30	16.0	2.30	15.1	2.24										
	JM	718	5642	10862		10542		10215		9873		9505		9106		8675		8215		7740		6710											
				22	2.24	22	2.31	21	2.36	20	2.42	19.9	2.45	19.1	2.48	18.3	2.49	17.2	2.49	17.1	2.48	16.1	2.45										
748	5875	11314		10998		10681		10365		10005		9624		9242		8814		8367		7394													
		24	2.53	23	2.60	22	2.67	22	2.72	21	2.77	19.8	2.79	18.9	2.81	18.4	2.81	17.7	2.81	16.9	2.79												

Performance certified is for installation type A: free inlet, free outlet. Performance rating includes the effects of bird screen.

Power rating (BHP) does not include transmission losses.

† The sound ratings shown are loudness values in fan sones at 5 ft. (1.5m) in a hemispherical free field calculated per AMCA standard 301. Values shown are for installation type A, free inlet hemispherical sone levels.

Centrifugal Ventilators

Belt-Drive Upblast Centrifugal Roof & Wall Ventilators

5BDU30 *cont.*

HP	Motor Options	RPM	TS (FPM)	0.0" SP		0.125" SP		0.250" SP		0.375" SP		0.500" SP		0.625" SP		0.750" SP		0.875" SP		1.00" SP		1.25" SP		1.50" SP		1.75" SP					
				CFM		CFM		CFM		CFM		CFM		CFM		CFM		CFM		CFM		CFM		CFM		CFM		CFM		CFM	
				Sones†	BHP#	Sones†	BHP#	Sones†	BHP#	Sones†	BHP#	Sones†	BHP#	Sones†	BHP#	Sones†	BHP#	Sones†	BHP#	Sones†	BHP#	Sones†	BHP#	Sones†	BHP#	Sones†	BHP#	Sones†	BHP#	Sones†	BHP#
5	KK	841	6606	12723	12450	12175	11892	11600	11291	10964	10616	10249	9462	8648	7693																
				28	3.60	28	3.68	27	3.75	26.3	3.82	25	3.88	25	3.93	24	3.96	23	3.98	23	4.00	21	4.00	21	3.98	20	3.92				
	KM	872	6845	13192	12929	12663	12393	12114	11821	11512	11186	10842	10102	9321	8510																
				30	4.02	29	4.09	28	4.17	28	4.24	28	4.30	27	4.36	26	4.40	25	4.43	25	4.45	24	4.46	22	4.45	22	4.42				
			887	6966	13417	13150	12883	12616	12350	12065	11744	11422	11100	10393	9638	8795															
					30	4.23	30	4.31	30	4.38	30	4.46	28	4.52	28	4.58	27	4.63	26	4.66	25	4.68	25	4.69	24	4.68	23	4.66			

5BDU36

HP	Motor Options	RPM	TS (FPM)	0.0" SP		0.125" SP		0.250" SP		0.375" SP		0.500" SP		0.625" SP		0.750" SP		0.875" SP		1.00" SP		1.25" SP		1.50" SP		1.75" SP					
				CFM		CFM		CFM		CFM		CFM		CFM		CFM		CFM		CFM		CFM		CFM		CFM		CFM		CFM	
				Sones†	BHP#	Sones†	BHP#	Sones†	BHP#	Sones†	BHP#	Sones†	BHP#	Sones†	BHP#	Sones†	BHP#	Sones†	BHP#	Sones†	BHP#	Sones†	BHP#	Sones†	BHP#	Sones†	BHP#	Sones†	BHP#	Sones†	BHP#
3/4	EB	293	2804	8117	7091	5805																									
				7.1	0.43	7.0	0.47	6.7	0.47																						
	EX	301	2878	8339	7341	6130																									
				7.6	0.47	7.5	0.50	7.2	0.52																						
	EL	339	3239	9392	8509	7552	6179																								
				9.3	0.67	8.6	0.71	8.4	0.74	7.9	0.73																				
1	FB	350	3342	9696	8844	7934	6741																								
				9.3	0.74	8.9	0.78	8.6	0.81	8.1	0.80																				
	FX	356	3398	9863	9025	8137	6991																								
				9.4	0.78	9.2	0.82	8.9	0.85	8.5	0.85																				
	FL	373	3564	10334	9532	8679	7654	6202																							
				10.9	0.89	9.8	0.94	9.4	0.98	8.9	0.98	8.3	0.94																		
	FM																														

Performance certified is for installation type A: free inlet, free outlet. Performance rating includes the effects of bird screen.

Power rating (BHP) does not include transmission losses.

† The sound ratings shown are loudness values in fan sones at 5 ft. (1.5m) in a hemispherical free field calculated per AMCA standard 301. Values shown are for installation type A, free inlet hemispherical sone levels.

Centrifugal Ventilators

Belt-Drive Upblast Centrifugal Roof & Wall Ventilators

5BDU36 cont.

HP	Motor Options	RPM	TS (FPM)	0.0" SP		0.125" SP		0.250" SP		0.375" SP		0.500" SP		0.625" SP		0.750" SP		0.875" SP		1.00" SP		1.25" SP		1.50" SP		1.75" SP					
				CFM		CFM		CFM		CFM		CFM		CFM		CFM		CFM		CFM		CFM		CFM		CFM		CFM		CFM	
				Sones†	BHP#	Sones†	BHP#	Sones†	BHP#	Sones†	BHP#	Sones†	BHP#	Sones†	BHP#	Sones†	BHP#	Sones†	BHP#	Sones†	BHP#	Sones†	BHP#	Sones†	BHP#	Sones†	BHP#	Sones†	BHP#	Sones†	BHP#
1-1/2	GB	399	3811	11054		10308		9542		8673		7563																			
				11.0	1.09	10.9	1.14	10.2	1.18	9.8	1.21	9.5	1.19																		
	GX	409	3911	11331		10603		9859		9034		7986																			
						11.6	1.18	11.4	1.22	10.9	1.27	10.3	1.30	9.7	1.29																
	GL	427	4080	11830		11129		10411		9645		8694		7443																	
						13.0	1.34	12.2	1.39	11.5	1.44	11.1	1.47	10.8	1.47	10.0	1.44														
	GM			12328		11661		10982		10267		9427		8409																	
				13.7	1.51	13.1	1.57	12.6	1.62	12.1	1.66	11.5	1.67	11.0	1.65																
2	HX	445	4252	12578		11924		11259		10565		9766		8793																	
				14.2	1.61	13.8	1.66	12.9	1.71	12.8	1.76	12.3	1.78	11.6	1.76																
	HM	454	4342	13021		12384		11748		11058		10336		9430		8267															
					15.5	1.78	14.6	1.84	14.1	1.89	13.5	1.94	13.1	1.97	12.5	1.96	12.0	1.92													
3	JX	520	4969	14406		13835		13260		12674		12060		11374		10566		9665													
				17.8	2.42	17.7	2.48	17.0	2.54	16.0	2.60	15.7	2.64	15.3	2.67	14.8	2.66	14.3	2.63												
	JM	531	5074	14711		14152		13589		13016		12421		11768		11004		10143													
						18.7	2.57	18.1	2.64	17.2	2.70	17.0	2.76	16.4	2.81	16.2	2.84	15.5	2.83	14.8	2.81										
		538	5141	14905		14349		13793		13224		12616		12008		11231		10432		9307											
					19.1	2.68	18.8	2.74	17.8	2.80	17.0	2.86	16.7	2.92	16.2	2.95	15.8	2.95	15.0	2.92	14.8	2.87									
5	KX	607	5799	16816		16328		15837		15342		14839		14321		13769		13156		12462		10877									
				22	3.84	22	3.92	21	3.99	20	4.06	20	4.12	19.3	4.18	19.0	4.23	18.6	4.24	18.0	4.23	16.8	4.16								
	KM	620	5922	17176		16698		16218		15733		15243		14739		14209		13629		12973		11485									
						23	4.10	23	4.17	22	4.24	21	4.31	20	4.38	20	4.45	19.3	4.50	19.2	4.52	18.7	4.52	17.4	4.45						
		637	6087	17647		17178		16708		16239		15763		15249		14736		14222		13573		12174		7546							
					23	4.44	23	4.52	23	4.59	21	4.67	21	4.74	21	4.81	20	4.86	20	4.90	19.8	4.90	18.4	4.85	17.3	3.55					

Performance certified is for installation type A: free inlet, free outlet. Performance rating includes the effects of bird screen.

Power rating (BHP) does not include transmission losses.

† The sound ratings shown are loudness values in fan sones at 5 ft. (1.5m) in a hemispherical free field calculated per AMCA standard 301. Values shown are for installation type A, free inlet hemispherical sone levels.

Centrifugal Ventilators

Belt-Drive Upblast Centrifugal Roof & Wall Ventilators – Octave Sound Data

The sound power ratings shown are in decibels, referred to 10^{-12} Watts calculated per AMCA Standard 301. Values shown are for inlet L_{w_i} A sound power levels for installation Type A: free inlet, free outlet. Ratings do not include the effects of duct end correction. For models shown on this page, the AMCA ratings seal applies to air performance and some values. For models shown on this page, the AMCA Certified Ratings Seal applies to air performance and sones only.

Model 5BDU10; Wheel Dia. 10-1/2" Sound Data											
HP	RPM	SP	63 Hz	125 Hz	250 Hz	500 Hz	1000 Hz	2000 Hz	4000 Hz	8000 Hz	L _{wi} A
1/6	1589	0	69	70	78	72	64	64	59	53	74
		0.5	66	69	76	69	61	60	54	49	71
1/4	1819	0	71	72	79	81	69	66	64	58	80
		0.5	69	72	79	79	67	64	60	54	78

Model 5BDU12; Wheel Dia. 12-1/4" Sound Data											
HP	RPM	SP	63 Hz	125 Hz	250 Hz	500 Hz	1000 Hz	2000 Hz	4000 Hz	8000 Hz	L _{wi} A
1/4	1423	0	70	73	80	71	65	67	61	54	75
		0.5	69	72	79	69	62	62	57	50	73
1/3	1566	0	69	74	81	74	67	68	64	56	77
		0.5	68	72	81	72	65	65	61	53	75
		1	68	69	77	69	61	61	57	51	72

Model 5BDU13; Wheel Dia. 13-1/2" Sound Data											
HP	RPM	SP	63 Hz	125 Hz	250 Hz	500 Hz	1000 Hz	2000 Hz	4000 Hz	8000 Hz	L _{wi} A
1/4	1210	0	70	72	81	71	64	67	60	51	76
		0.5	69	71	78	69	61	63	56	50	73
1/3	1330	0	71	75	83	74	66	69	64	55	78
		0.5	70	74	81	72	64	67	60	53	75
1/2	1530	0	72	80	86	78	69	70	69	60	81
		0.5	71	79	84	77	67	69	66	58	79
		1	70	76	81	73	64	68	61	55	76

Model 5BDU15; Wheel Dia. 15" Sound Data											
HP	RPM	SP	63 Hz	125 Hz	250 Hz	500 Hz	1000 Hz	2000 Hz	4000 Hz	8000 Hz	L _{wi} A
1/4	1033	0	68	76	79	70	65	66	58	55	74
		0.5	68	74	78	67	62	59	55	51	72
1/3	1136	0	69	76	81	72	66	67	62	57	76
		0.5	69	75	80	70	65	63	58	53	74
1/2	1301	0	70	77	84	75	68	68	67	60	78
		0.5	70	76	83	73	67	67	65	57	77
3/4	1489	0	73	78	86	79	71	71	71	64	81
		0.5	72	77	85	78	70	70	70	61	81
		1	72	76	84	76	69	70	65	60	79
1	1639	0	75	80	86	83	74	73	73	67	84
		0.5	74	79	86	82	73	72	72	65	83
		1	74	78	85	80	71	71	69	63	81
		1.5	75	78	83	78	69	69	67	61	79

Model 5BDU16; Wheel Dia. 16-1/2" Sound Data											
HP	RPM	SP	63 Hz	125 Hz	250 Hz	500 Hz	1000 Hz	2000 Hz	4000 Hz	8000 Hz	L _{wi} A
1/3	960	0	75	74	80	73	68	65	58	52	75
		0.5	73	72	77	69	61	58	53	49	72
1/2	1100	0	72	75	84	76	71	69	62	56	79
		0.5	70	74	81	73	65	64	58	53	76
3/4	1260	0	72	78	87	79	74	73	66	60	82
		0.5	71	77	85	77	70	69	63	57	80
		1	69	75	83	74	65	64	60	55	77
1	1400	0	74	81	89	81	76	76	70	63	84
		0.5	72	80	88	79	73	73	67	61	83
		1	70	78	87	77	70	69	64	59	81

Model 5BDU18; Wheel Dia. 18-1/4" Sound Data											
HP	RPM	SP	63 Hz	125 Hz	250 Hz	500 Hz	1000 Hz	2000 Hz	4000 Hz	8000 Hz	L _{wi} A
1/3	811	0	68	78	73	70	63	62	59	50	71
		0.5	67	78	71	67	60	58	53	46	69
1/2	928	0	71	79	77	73	66	64	61	54	74
		0.5	70	78	75	71	63	62	58	51	72
3/4	1062	0	73	79	81	76	69	67	64	60	78
		0.5	73	78	81	75	66	66	63	57	77
1	1169	0	75	80	85	79	72	70	67	64	81
		0.5	75	79	85	78	69	68	66	61	80
		1	74	77	82	76	67	66	64	58	78
1 1/2	1338	0	76	82	88	81	74	74	70	68	84
		0.5	75	82	88	80	73	72	68	65	83
		1	74	80	86	78	70	69	67	62	81
2	1473	0	77	84	90	83	76	77	72	71	86
		0.5	76	84	90	82	75	75	70	69	85
		1	74	82	88	79	73	72	69	66	83
		1.5	75	80	86	78	72	70	68	64	81

Centrifugal Ventilators

Belt-Drive Upblast Centrifugal Roof & Wall Ventilators – Octave Sound Data

Model 5BDU20; Wheel Dia. 20" Sound Data												
HP	RPM	SP	63 Hz	125 Hz	250 Hz	500 Hz	1000 Hz	2000 Hz	4000 Hz	8000 Hz	LwIA	
1/3	699	0	74	77	74	73	65	60	56	63	74	
		0.5	72	75	74	71	64	58	54	52	72	
1/2	800	0	76	79	77	75	67	63	59	61	76	
		0.5	76	77	77	75	66	63	57	54	75	
3/4	915	0	79	81	81	78	69	67	62	58	78	
		0.5	79	80	81	78	69	67	62	58	78	
1	1010	0	80	83	83	80	71	70	65	60	80	
		0.5	80	82	83	80	71	69	64	61	80	
		1	79	81	81	79	69	68	63	61	79	
1 1/2	1155	0	82	86	86	83	75	74	68	64	84	
		0.5	81	86	86	82	75	73	68	63	83	
		1	82	85	85	82	73	72	67	62	83	
2	1270	0	83	88	88	85	78	77	72	67	86	
		0.5	82	88	88	85	77	76	71	66	86	
		1	82	88	88	84	76	75	70	65	85	
		1.5	84	88	86	83	75	75	70	66	84	

Model 5BDU30; Wheel Dia. 30" Sound Data												
HP	RPM	SP	63 Hz	125 Hz	250 Hz	500 Hz	1000 Hz	2000 Hz	4000 Hz	8000 Hz	LwIA	
1/2	412	0	74	91	71	71	69	59	54	54	78	
		0.5	75	90	74	72	71	64	58	55	78	
3/4	471	0	73	90	71	67	62	58	55	52	75	
		0.5	76	89	76	73	72	67	60	56	78	
1	519	0	74	89	73	69	66	61	56	53	75	
		0.5	77	88	80	74	75	73	64	58	80	
1 1/2	594	0	76	87	77	72	73	67	59	56	78	
		0.5	79	86	82	75	77	78	67	60	83	
2	653	0	77	86	80	73	78	72	62	58	81	
		0.5	77	86	80	73	78	72	62	58	81	
		1	77	84	77	72	70	64	60	56	75	
3	748	0	80	87	87	77	78	81	72	64	86	
		0.5	79	87	85	76	81	78	68	62	85	
		1	79	86	83	75	76	71	64	61	81	
5	887	0	82	90	94	82	81	85	79	70	90	
		0.5	82	89	93	81	81	84	76	68	89	
		1	80	88	90	80	80	80	71	66	87	
		1.5	82	88	89	78	78	77	70	66	85	

Model 5BDU24; Wheel Dia. 24-1/2" Sound Data												
HP	RPM	SP	63 Hz	125 Hz	250 Hz	500 Hz	1000 Hz	2000 Hz	4000 Hz	8000 Hz	LwIA	
1/3	495	0	72	76	75	72	67	60	58	60	73	
		0.5	74	79	77	74	69	63	60	61	75	
1/2	570	0	71	78	75	71	66	60	57	56	73	
		0.5	76	82	80	75	71	66	63	61	77	
3/4	650	0	74	82	78	73	68	64	59	55	75	
		0.5	77	84	80	77	73	69	65	62	79	
1	720	0	76	84	80	75	71	67	61	57	78	
		0.5	79	86	77	80	77	74	68	65	82	
1 1/2	820	0	77	85	86	79	75	71	65	62	82	
		0.5	73	83	83	76	71	67	62	59	79	
		1	73	83	83	76	71	67	62	59	79	
2	900	0	80	88	74	83	80	77	71	67	85	
		0.5	78	86	87	83	79	75	69	65	85	
		1	76	83	86	81	74	71	65	62	83	

Model 5BDU36; Wheel Dia. 36-1/2" Sound Data												
HP	RPM	SP	63 Hz	125 Hz	250 Hz	500 Hz	1000 Hz	2000 Hz	4000 Hz	8000 Hz	LwIA	
3/4	339	0	74	72	71	68	66	58	53	50	70	
		0.5	76	75	73	69	68	60	56	52	72	
1	373	0	78	80	77	71	70	64	60	56	75	
		0.5	76	77	74	69	67	62	57	54	72	
1 1/2	427	0	80	83	80	73	73	67	64	60	78	
		0.5	78	82	77	70	69	65	61	58	75	
2	470	0	82	87	84	76	75	71	67	64	81	
		0.5	81	85	82	73	73	69	65	62	79	
3	538	0	84	90	88	80	79	77	71	68	85	
		0.5	83	88	87	78	78	74	70	66	84	
		1	80	87	84	76	75	72	69	65	81	

Typical Specifications

Belt-Drive Upblast Roof and Wall

Roof mount exhaust fans shall be upblast centrifugal belt-driven type. The fan wheel shall be centrifugal backward inclined, blades and wheel cone to be constructed of aluminum and shall include a wheel cone matched to the inlet cone for precise running tolerances. Wheels shall be statically and dynamically balanced. The fan housing shall be constructed of heavy gauge aluminum with a rigid steel internal support structure. Windbands shall have a rolled bead for added strength and shall be joined to curb caps with a leak resistant, continuously welded seam. Motors shall be heavy-duty ball bearing type, matched to the fan load, furnished at the specified voltage, phase and enclosure. Motors and drives shall be mounted out of the airstream. Fresh air for motor cooling shall be drawn into the motor compartment from an area free of discharge contaminants. Motors shall be readily accessible for maintenance. Steel shafts shall be turned, ground, polished and mounted in permanently sealed and lubricated ball bearings (30" and 36" units feature regreaseable pillow block bearings). Bearings shall be selected for a minimum (L50) life in excess of 200,000 hours at maximum cataloged operating speed. Drives shall be sized for a minimum of 150% of driven horsepower. Pulleys shall be of the fully machined cast iron type, keyed and securely attached to the wheel and motor shafts. Motor pulleys shall be adjustable for final system balancing. A junction box shall be factory installed to permit a disconnect switch to be wired to the fan motor within the motor compartment. A conduit chase shall be provided through the curb cap to the motor compartment for ease of electrical wiring. The drive assembly and wheel shall be removable from the support structure without disassembling the external fan housing. All fans shall bear the AMCA Certified Ratings Seal for sound and air performance. Each fan shall bear a permanently affixed manufacturer's nameplate containing model number, drive selections and will carry a one-year warranty. Fans shall be Fantech Model Belt-Drive Upblast Centrifugal Roof & Wall Ventilators – Octave Sound Data as manufactured by Systemair Mfg. Inc., Lenexa, Kansas.

Centrifugal Ventilators

Belt-Drive Upblast Centrifugal Roof & Wall Ventilators – Performance Curves

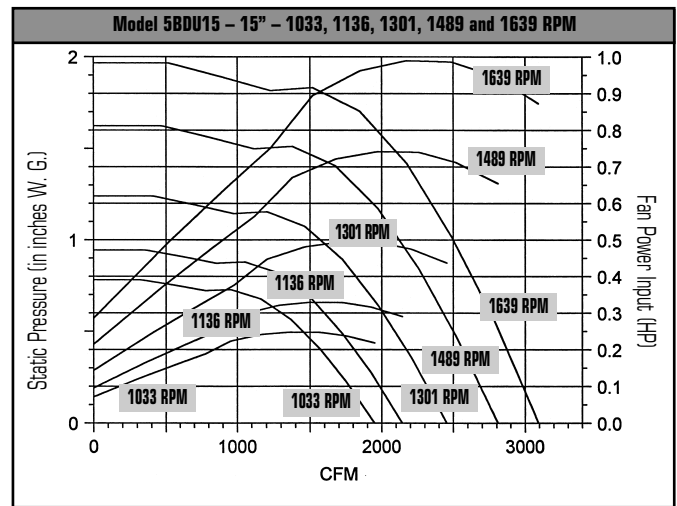
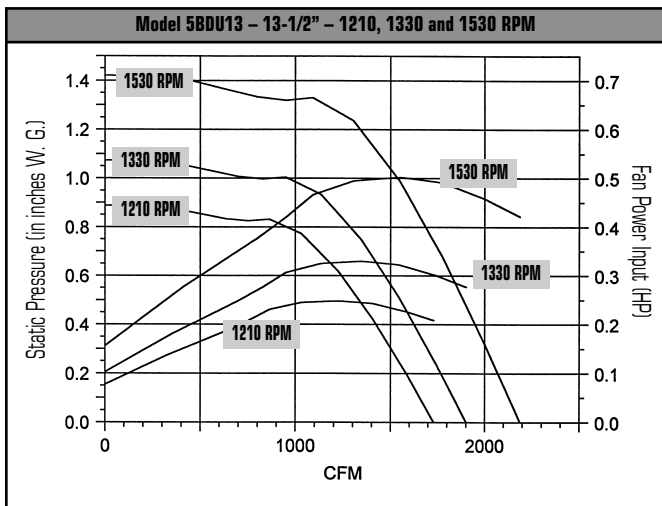
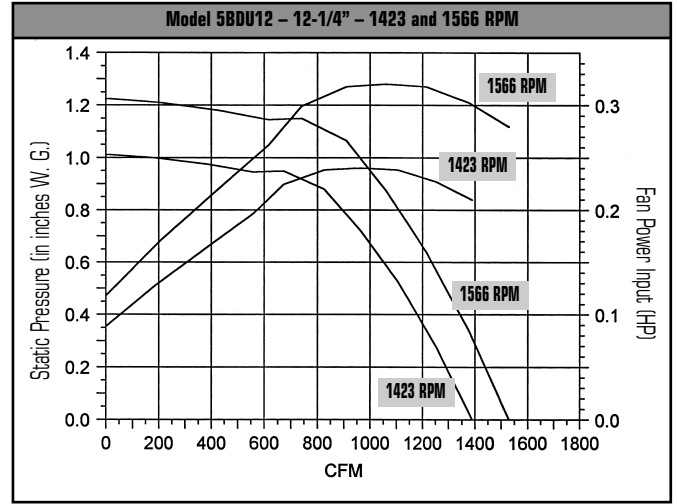
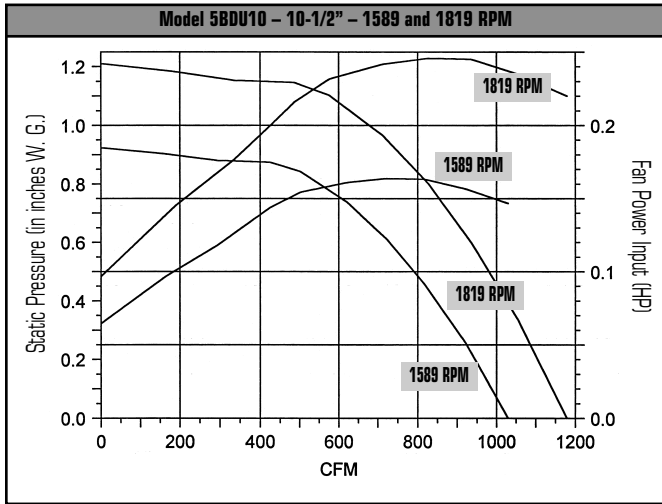

Performance certified is for installation type A: free inlet, free outlet. Performance rating includes the effects of bird screen.

Centrifugal Ventilators

Belt-Drive Upblast Centrifugal Roof & Wall Ventilators – Performance Curves

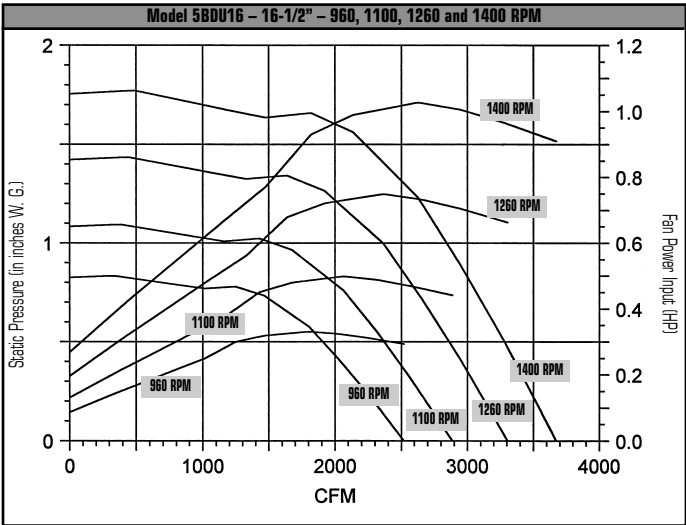
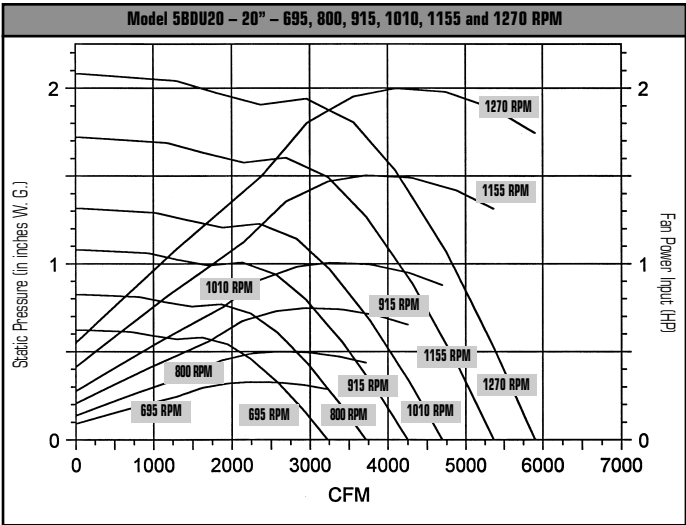
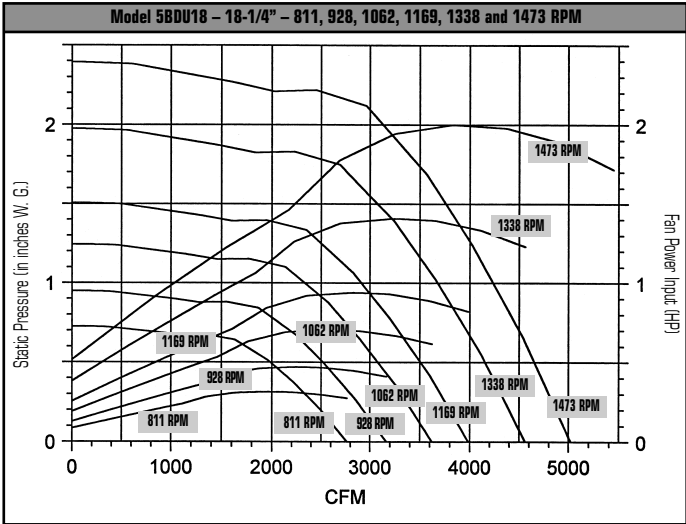

Performance certified is for installation type A: free inlet, free outlet. Performance rating includes the effects of bird screen.

Centrifugal Ventilators

Belt-Drive Upblast Centrifugal Roof & Wall Ventilators – Performance Curves

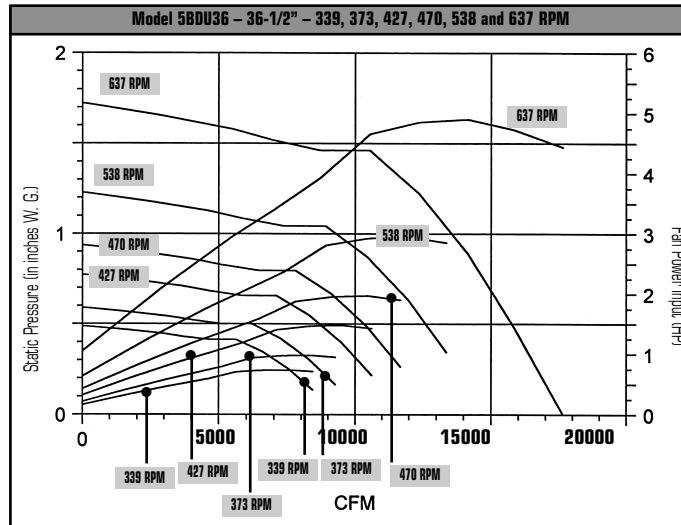
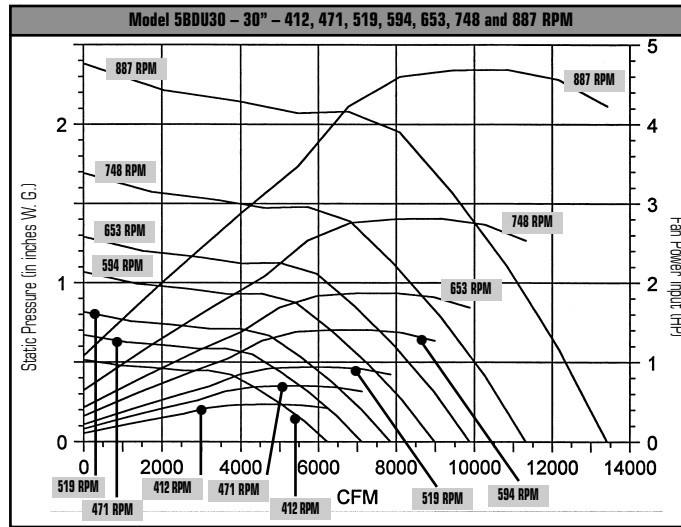
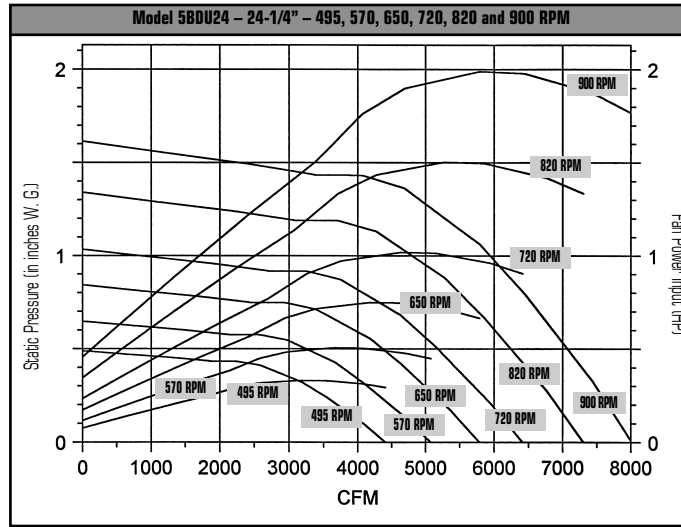

Performance certified is for installation type A: free inlet, free outlet. Performance rating includes the effects of bird screen.

Filtered Supply Ventilators

Belt-Drive Filtered Supply

Belt-drive filtered supply ventilators are designed to be installed on the roof or wall (15", 18", 20" units roof-mount only). The single-sided units provide filtered supply air to industrial and commercial buildings and can easily be used in commercial or industrial kitchen applications. Units include one set of 1" washable aluminum filters.

Agency Listing

- All ventilators are UL Standard 705 listed power ventilators when sold complete with motor and variable pitch drive
- All motor and drive packages comply with the minimum efficiency levels of EPC Act '92. Affected motors bear the  seal
- Ventilators are CSA listed according to Standard C22.2 No. 113-M1984 (Fans & Ventilators) when sold complete with motor and variable pitch drive
- AMCA licensed for sound and air

Features and Specifications

- Lifting lugs are standard on all sizes for ease of transport
- 10" - 18" units feature permanently lubricated, maintenance-free bearings
- 20" unit features regreaseable pillow block bearing
- Variable pitch sheaves to allow speed and CFM adjustments
- Dual-mount structure for either wall or roof mounting of the 10" and 12" units
- Galvanized metal housing and base

Accessories (available separately)

- For more information, see Power Roof Ventilator Accessories
- NEMA 1, NEMA 3R and NEMA 4 disconnect switches
- Fixed mounting curbs
- Filters



Fantech, Inc. and Systemair Mfg. Inc. certify that the Belt-Drive Filtered Supply shown herein are licensed to bear the AMCA Seal. The ratings shown are based on tests and procedures performed in accordance with AMCA Publication 211 and AMCA Publication 311 and comply with the requirements of the AMCA Certified Ratings Program.

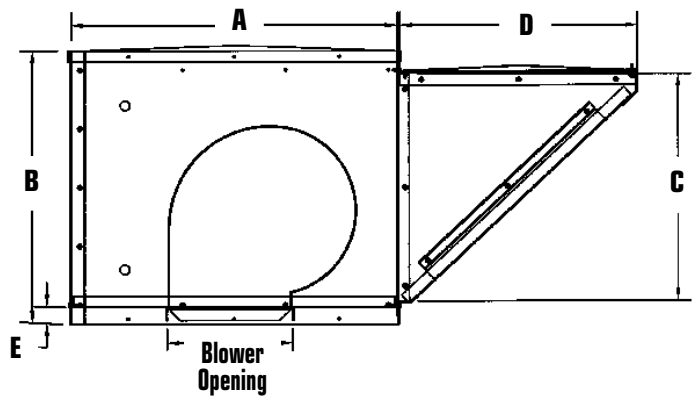

Model No.	Blower Dia. (In.)	Blower Opening (In.)	Wheel Bore Size (In.)	Dimensions (In.)					Ship Wt. (Lbs.) (less motor assembly)	Max Ship Wt. (Lbs.)	Optional Accessories - Roof Curb	
				A	B	C	D	E			8" Height Model No.	12" Height Model No.
5FSU10	10	11-3/8 x 13-1/8	3/4	30	25	21	22	1-1/2	164	202	5ACC28FS	5ACC28FT
5FSU12	12	13-7/16 x 15-5/8	3/4	34-1/2	32	26	30	2	261	306	5ACC32FS	5ACC32FT
5FSU15	15	15-7/8 x 18-5/8	1	34-1/2	32	26	30	2	267	310	5ACC32FS	5ACC32FT
5FSU18	18	18-7/8 x 21-7/8	1	42	36	31	33	2	461	538	5ACC40FS	5ACC40FT
5FSU20	20	24-3/4 x 22-3/4	1-3/16	46	48	36	38	2	550	683	5ACC44FS	5ACC44FT

MOTOR SELECTION GUIDE

Dia. (In.)	HP	Open Dripproof		Dia. (In.)	HP	Open Dripproof	
		Single Phase	Three Phase			Single Phase	Three Phase
10	1/6	AB	—	12-18	1-1/2	GB	GX
10	1/4	BB	—	15-18	2	—	HX
10-12	1/3	CB	—	18	3	—	JX
10-15	1/2	DB	DX	18-20	5	—	KX
10-15	3/4	EB	EX	20	7-1/2	—	LX
10-15	1	FB	FX	20	10	—	MX

B = 115/230/60/1 Open Dripproof
 X = 208-220/440/60/3 Open Dripproof
 For fan with motor and drive package, add the two-digit motor HP, phase and enclosure code.
 Example: 5FSU10AB

Supply Dampers

Model No.	Dampers
5FSU10	5ACC23SD
5FSU12	5ACC27SD
5FSU15	5ACC27SD
5FSU18	5ACC35SD
5FSU20	5ACC39SD

Filtered Supply Ventilators

Belt-Drive Filtered Supply

5FSU10

HP	Motor Options	RPM	TS (FPM)	Max. BHP†	.125" SP	.250" SP	.375" SP	.500" SP	.750" SP	1.000" SP	1.250" SP	1.500" SP	2.000" SP	
					CFM	CFM	CFM	CFM	CFM	CFM	CFM	CFM	CFM	CFM
					LWA#	LWA#	LWA#	LWA#	LWA#	LWA#	LWA#	LWA#	LWA#	LWA#
1/6	AB	600	1571	0.19	1365	1037	173							
					—	76	—							
1/4	BB	689	1804	0.29	1647	1387	1044	184						
					—	81	—	—						
1/3	CB	760	1990	0.38	1863	1637	1377	697						
					—	82	—	—						
1/2	DB DX	870	2278	0.58	2184	2000	1792	1558	334					
					—	82	—	—	—					
3/4	EB EX	990	2592	0.85	2528	2377	2205	2017	1564	326				
					—	83	—	—	—	—				
1	FB FX	1090	2854	1.13	2811	2679	2527	2368	2011	1420				
					—	84	—	—	—	—				

5FSU12

HP	Motor Options	RPM	TS (FPM)	Max. BHP†	.125" SP	.250" SP	.375" SP	.500" SP	.750" SP	1.000" SP	1.250" SP	1.500" SP	2.000" SP	
					CFM	CFM	CFM	CFM	CFM	CFM	CFM	CFM	CFM	CFM
					LWA#	LWA#	LWA#	LWA#	LWA#	LWA#	LWA#	LWA#	LWA#	LWA#
1/3	CB	550	1728	0.35	2151	1737	519							
					—	68	—							
1/2	DB DX	640	2011	0.55	2604	2311	1872	692						
					—	74	—	—						
3/4	EB EX	725	2278	0.79	3021	2769	2468	2053	344					
					—	79	—	—	—					
1	FB FX	810	2545	1.10	3431	3206	2980	2678	1843	231				
					—	82	—	—	—	—				
1 1/2	GB GX	890	2796	1.47	3813	3608	3402	3176	2531	706	161			
					—	84	—	—	—	—	—	—		

Performance certified is for installation type B: Free Inlet, Ducted Outlet. Performance ratings include the effects of filters. † Power ratings (BHP) do not include transmission losses. The A-weighted sound ratings are calculated per AMCA Standard 301. # Values shown are for total LWA sound power levels for Installation Type B: Free Inlet, Ducted Outlet. Ratings include the effects of duct end correction for the outlet duct.

Filtered Supply Ventilators

Belt-Drive Filtered Supply

5FSU15

HP	Motor Options	RPM	TS (FPM)	Max. BHP†	.125" SP	.250" SP	.375" SP	.500" SP	.750" SP	1.000" SP	1.250" SP	1.500" SP	2.000" SP	
					CFM	CFM	CFM	CFM	CFM	CFM	CFM	CFM	CFM	CFM
					LWA#	LWA#	LWA#	LWA#	LWA#	LWA#	LWA#	LWA#	LWA#	
1/2	DB DX	535	2101	0.58	3040	2628	2060	870						
					—	71	—	—						
3/4	EB EX	605	2376	0.83	3522	3187	2777	2231	501					
					—	76	—	—	—					
1	FB FX	670	2631	1.13	3963	3671	3345	2931	1283	336				
					—	78	—	—	—	—				
1 1/2	GB GX	745	2926	1.56	4464	4216	3933	3616	2780	1079	340			
					—	81	—	—	—	—	—			
2	HX	820	3220	2.07	4961	4738	4492	4235	3584	2728	1029	407		
					—	83	—	—	—	—	—	—		

5FSU18

HP	Motor Options	RPM	TS (FPM)	Max. BHP†	.125" SP	.250" SP	.375" SP	.500" SP	.750" SP	1.000" SP	1.250" SP	1.500" SP	2.000" SP	
					CFM	CFM	CFM	CFM	CFM	CFM	CFM	CFM	CFM	CFM
					LWA#	LWA#	LWA#	LWA#	LWA#	LWA#	LWA#	LWA#	LWA#	
1 1/2	GB GX	592	2790	1.50	5409	4989	4515	4043	2386	809				
					—	79	—	—	—	—				
2	HX	665	3134	2.12	6161	5825	5403	4982	3995	2361	947	133		
					—	82	—	—	—	—	—	—		
3	JX	770	3628	3.29	7230	6948	6629	6264	5537	4649	3251	1930	185	
					—	86	—	—	—	—	—	—		
5	KX	920	4335	5.61	8739	8503	8267	8007	7396	6788	6181	5278	2940	
					—	91	—	—	—	—	—	—		

Performance certified is for installation type B: Free Inlet, Ducted Outlet. Performance ratings include the effects of filters. † Power ratings (BHP) do not include transmission losses. The A-weighted sound ratings are calculated per AMCA Standard 301. # Values shown are for total LWA sound power levels for Installation Type B: Free Inlet, Ducted Outlet. Ratings include the effects of duct end correction for the outlet duct.

Filtered Supply Ventilators

Belt-Drive Filtered Supply

5FSU20

HP	Motor Options	RPM	TS (FPM)	Max. BHP†	.125" SP	.250" SP	.375" SP	.500" SP	.750" SP	1.000" SP	1.250" SP	1.500" SP	2.000" SP	
					CFM	CFM	CFM	CFM	CFM	CFM	CFM	CFM	CFM	CFM
					LWA#	LWA#	LWA#	LWA#	LWA#	LWA#	LWA#	LWA#	LWA#	LWA#
5	KX	670	3508	4.97	10394	10057	9720	9345	8515	7593	6527	4259	950	
					—	88	—	—	—	—	—	—	—	—
7 1/2	LX	790	4136	8.15	12255	11969	11684	11398	10727	10023	9244	8435	5391	
					—	93	—	—	—	—	—	—	—	—
10	MX	885	4634	11.45	13729	13474	13219	12964	12418	11789	11160	10461	8928	
					—	96	—	—	—	—	—	—	—	—

Performance certified is for installation type B: Free Inlet, Ducted Outlet. Performance ratings include the effects of filters. † Power ratings (BHP) do not include transmission losses. The A-weighted sound ratings are calculated per AMCA Standard 301. # Values shown are for total LWA sound power levels for Installation Type B: Free Inlet, Ducted Outlet. Ratings include the effects of duct end correction for the outlet duct.

Axial Ventilators

Direct-Drive Axial Exhaust Downblast Roof Ventilators

Direct-drive axial roof ventilators are designed for use in applications requiring the steady exhaust of air under low to moderate static pressures.

Agency Listing

- All ventilators are UL Standard 705 listed
- Ventilators are CSA listed according to Standard C22.2 No. 113-M1984 (Fans & Ventilators)

Ventilator Construction

- 10", 12", 14" and 16" models are wall mountable
- Durable spun aluminum hood construction and galvanized venturi, inlet and supports
- Stamped, aluminum axial fan blades with galvanized hub
- Externally cooled motor compartment
- Motors are 115V or 115/230V, 60 Hz, ball bearing motors with Class B insulation
- Maximum inlet temperature is 140°F
- Built-in bird screen to protect discharge and ensure safe, obstruction-free operation

- Motor and propeller are easily detachable without removing ventilator from curb
- Junction box mounted in motor compartment
- Windband rolled bead for added strength and easy maneuverability
- Welded curb cap corners eliminate water entry into ducts or building
- All units require single phase power and are fully speed-controllable (5ADE18GB, 5ADE20GB and 5ADE24FB are not speed-controllable)

Accessories (available separately)

- For more information, see Power Roof Ventilator Accessories
- Fixed ventilated mounting curbs.
- Speed controllers.
- NEMA 1, NEMA 3R and NEMA 4 disconnect switches.
- Backdraft dampers.

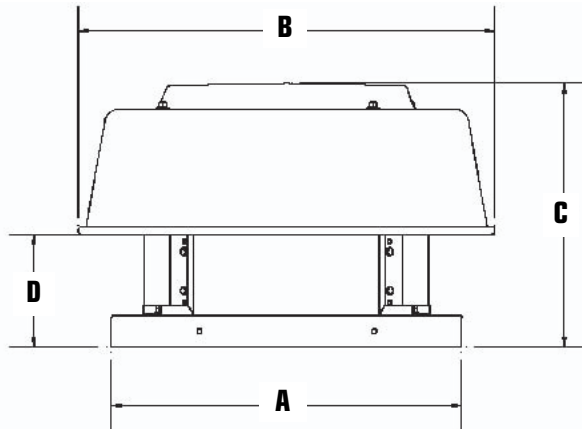

Fantech, Inc. and Systemair Mfg. Inc. certify that the Direct-Drive Axial Exhaust Downblast Roof Ventilators shown herein are licensed to bear the AMCA Seal. The ratings shown are based on tests and procedures performed in accordance with AMCA Publication 211 and AMCA Publication 311 and comply with the requirements of the AMCA Certified Ratings Program.

Model No.	Fan Dia. (In.)	Dimensions (In.)				Total Ship Wt. (Lbs.)	Gauge Thickness (In.)		Recommended Roof Opening (In.)	Optional Accessories			
		A	B	C	D		Venturi	Hood		Exhaust Damper Model No.	8" Fixed Curb Model No.	12" Fixed Curb Model No.	Speed Controller Model No.
5ADE102A	10	19	23-5/8	13-3/8	5-1/2	35	0.063	0.13	14-1/2 x 14-1/2	5ACC12RD	5ACC17FS	5ACC17FT	5ACC03SC
5ADE121A	12	22	28	15-1/2	6-1/2	54	0.063	0.13	14-1/2 x 14-1/2	5ACC15RD	5ACC20FS	5ACC20FT	5ACC03SC
5ADE12BA	12	22	28	15-1/2	6-1/2	54	0.063	0.13	14-1/2 x 14-1/2	5ACC15RD	5ACC20FS	5ACC20FT	5ACC03SC
5ADE14AA	14	22	30-1/8	15-1/2	6-5/16	62	0.063	0.03	17-1/2 x 17-1/2	5ACC15RD	5ACC20FS	5ACC20FT	5ACC03SC
5ADE14EA	14	22	30-1/8	15-1/2	6-5/16	62	0.063	0.03	17-1/2 x 17-1/2	5ACC15RD	5ACC20FS	5ACC20FT	5ACC06SC
5ADE16AA	16	26	33-1/4	16-1/2	6-1/8	68	0.063	0.03	21-1/2 x 21-1/2	5ACC19RD	5ACC24FS	5ACC24FT	5ACC03SC
5ADE16EA	16	26	33-1/4	16-1/2	6-1/8	68	0.063	0.03	21-1/2 x 21-1/2	5ACC19RD	5ACC24FS	5ACC24FT	5ACC06SC
5ADE18CA	18	30	36	18-3/4	7-1/2	86	0.063	0.03	25-1/2 x 25-1/2	5ACC23RD	5ACC28FS	5ACC28FT	5ACC06SC
5ADE18GB	18	30	36	18-3/4	7-1/2	96	0.063	0.03	25-1/2 x 25-1/2	5ACC23RD	5ACC28FS	5ACC28FT	—
5ADE20DB	20	34	38-3/4	18-3/4	7-1/2	128	0.063	0.03	29-1/2 x 29-1/2	5ACC27RD	5ACC32FS	5ACC32FT	5ACC06SC
5ADE20GB	20	34	38-3/4	18-3/4	7-1/2	128	0.063	0.03	29-1/2 x 29-1/2	5ACC27RD	5ACC32FS	5ACC32FT	—
5ADE24DB	24	34	45	18-3/4	7-1/2	140	0.063	0.03	29-1/2 x 29-1/2	5ACC27RD	5ACC32FS	5ACC32FT	5ACC10SC
5ADE24FB	24	34	45	18-3/4	7-1/2	140	0.063	0.03	29-1/2 x 29-1/2	5ACC27RD	5ACC32FS	5ACC32FT	—

Axial Ventilators

Direct-Drive Axial Exhaust Downblast Roof Ventilators

Model No.	HP	RPM	TS (FPM)	Max. BHP	Volts	0.0" SP	0.125" SP	0.250" SP	0.375" SP	0.500" SP	0.625" SP	0.750" SP	0.875" SP	1.00" SP	
					Max. Op. Amps	CFM	CFM	CFM	CFM	CFM	CFM	CFM	CFM	CFM	CFM
						Sones†	Sones†	Sones†	Sones†	Sones†	Sones†	Sones†	Sones†	Sones†	Sones†
5ADE102A	1/30	1759	4605	—	115	547	423	269	191						
					0.9	8.9	9.1	9.3	10.0						
5ADE121A	1/5	1157	3635	0.11	115	1000	740	526	351	137					
					1.6	6.3	6.4	7.2	11.2	—					
5ADE12BA	1/4	1764	5542	0.18	115	1423	1219	993	891	644	441	225			
					2.3	10.0	10.5	10.8	13.0	15.3	—	—			
5ADE14AA	1/6	1152	4222	0.15	115	1640	1363	1065	614	221					
					2.0	7.4	7.5	8.1	10.5	12.6					
5ADE14EA	3/4	1743	6388	0.37	115	2379	2218	2013	1791	1488	1189	726	253		
					3.7	13.4	13.3	13.2	15.0	16.7	20	23	19.5		
5ADE16AA	1/6	1130	4733	0.20	115	2072	1735	1394	940	497					
					2.2	9.9	10.3	11.3	11.7	12.0					
5ADE16EA	3/4	1730	7246	0.49	115	2767	2571	2367	2159	1958	1625	1377	1155	936	
					4.5	17.9	17.2	16.5	18.0	19.3	21	22	24	26	
5ADE18CA	1/3	1093	5150	0.41	115	2989	2596	2328	2076	1841	1628	1192	741	313	
					4.7	11.6	11.0	10.3	12.0	13.5	15.7	—	—	—	
5ADE18GB	1 1/2	1716	8086	1.0	115/230	4525	4151	3973	3775	3558	3343	3147	2792	2370	
					10.7/5.4	23	23	23	24	24	24	24	26	28	30
5ADE20DB	1/2	1113	5827	0.55	115/230	3716	3448	3109	2779	2513	2053	1590	1263	847	
					4.2/2.6	14.7	14.6	14.6	15.0	15.1	17.6	19.9	—	—	
5ADE20GB	1 1/2	1695	8875	1.3	115/230	5275	5002	4748	4486	4197	3921	3636	3274	2997	
					12.6/6.3	27	28	29	30	30	28	26	29	32	
5ADE24DB	1/2	1045	6566	0.57	115/230	4769	4429	4098	3694	3195	2568	2017	1546	1094	
					7.4/3.8	19.2	19.0	17.5	16.7	16.4	—	—	—	—	
5ADE24FB	1	1096	6886	0.90	115/230	5379	5024	4595	4168	3821	3455	2989	2409	2024	
					10.4/5.2	21	20	19.0	22	24	22	20	23	—	

Performance certified is for installation type A: Free Inlet, Free Outlet. Performance ratings include the effects of bird screens. Speed (RPM) shown is nominal, and performance shown is based on actual speed of test.

† The sound ratings are loudness values in fan sones at 5 ft. (1.5m) in a hemispherical free field calculated per AMCA standard 301. Values shown are for Installation Type A, Free Inlet hemispherical sone levels.

Typical Specifications:

Direct-Drive Axial Exhaust Roof Ventilators

Roof mount exhaust fans shall be axial downblast direct-drive type. Propeller shall be constructed of a steel hub with galvalum or aluminum blades. Propellers shall be statically and dynamically balanced. The fan housing shall be constructed of heavy gauge aluminum with a rigid steel support structure. Baffles and motor compartment hoods shall have a rolled bead for added strength. Motors shall be readily accessible for maintenance. A junction box shall be factory installed to permit a disconnect switch to be wired to the fan motor within the motor compartment. A conduit chase shall be provided through the curb cap to the motor compartment for ease of electrical wiring. All fans shall bear the AMCA Certified Ratings Seal for sound and air performance. Each fan shall bear a permanently affixed manufacturer's nameplate containing model number and carry a one-year warranty. Fans shall be Fantech Model Direct-Drive Axial Exhaust Downblast Roof Ventilators as manufactured by Systemair Mfg. Inc., Lenexa, Kansas.

Axial Ventilators

Direct-Drive Axial Supply Downblast Roof Ventilators

Direct-drive axial roof ventilators are designed for use in applications requiring the steady supply of air under low to moderate static pressures.

Agency Listing

- All ventilators are UL Standard 705 listed
- Ventilators are CSA listed according to Standard C22.2 No. 113-M1984 (Fans & Ventilators)

Ventilator Construction

- 10", 12", 14" and 16" models are wall mountable
- Durable spun aluminum hood construction and galvanized venturi, inlet and supports
- Stamped, aluminum axial fan blades with galvanized hub
- Externally cooled motor compartment
- Motors are 115V or 115/230V, 60 Hz, ball bearing motors with Class B insulation
- Maximum inlet temperature is 140°F

- Built-in bird screen to protect discharge and ensure safe, obstruction-free operation
- Motor and blade are easily detachable without removing ventilator from curb
- Junction box mounted in motor compartment
- Windband rolled bead for added strength and easy maneuverability
- Welded curb cap corners eliminate water entry into ducts or building
- All units require single phase power and are fully speed-controllable (5ADS18GB, 5ADS20GB and 5ADS24FB are not speed-controllable)

Accessories (available separately)

- For more information, see Power Roof Ventilator Accessories
- Fixed ventilated mounting curbs.
- Speed controllers.
- NEMA 1, NEMA 3R and NEMA 4 disconnect switches.
- Backdraft dampers.

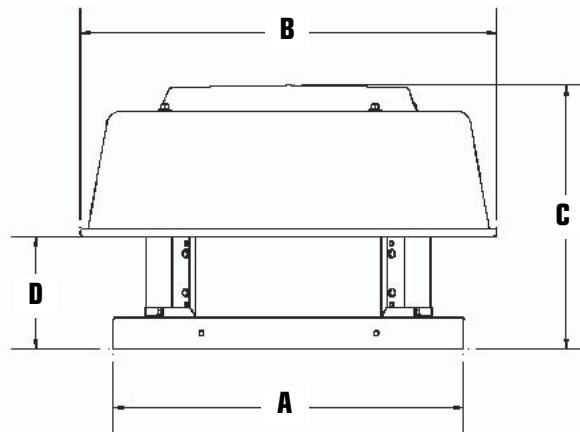

Fantech, Inc. and Systemair Mfg. Inc. certify that the Direct-Drive Axial Supply Downblast Roof Ventilators shown herein are licensed to bear the AMCA Seal. The ratings shown are based on tests and procedures performed in accordance with AMCA Publication 211 and AMCA Publication 311 and comply with the requirements of the AMCA Certified Ratings Program.

Model No.	Fan Dia. (In.)	Dimensions (In.)				Total Ship Wt. (lbs.)	Gauge Thickness (In.)		Recommended Roof Opening (In.)	Optional Accessories			
		A	B	C	D		Venturi	Hood		8" Fixed Curb Model No.	12" Fixed Curb Model No.	Speed Controller Model No.	Supply Dampers
5ADS12AA	12	19	28	15-1/2	6-1/2	54	0.063	0.13	14-1/2 x 14-1/2	5ACC20FS	5ACC20FT	5ACC03SC	5ACC15SD
5ADS12BA	12	22	28	15-1/2	6-1/2	54	0.063	0.13	14-1/2 x 14-1/2	5ACC20FS	5ACC20FT	5ACC03SC	5ACC15SD
5ADS14BA	14	22	30-1/8	15-1/2	6-5/16	62	0.063	0.03	17-1/2 x 17-1/2	5ACC20FS	5ACC20FT	5ACC03SC	5ACC15SD
5ADS14EA	14	22	30-1/8	15-1/2	6-5/16	62	0.063	0.03	17-1/2 x 17-1/2	5ACC20FS	5ACC20FT	5ACC05SC	5ACC15SD
5ADS16EAW	16	26	33-1/4	16-1/2	6-1/8	68	0.063	0.03	21-1/2 x 21-1/2	5ACC24FS	5ACC24FT	5ACC03SC	5ACC19SD
5ADS16EAY	16	26	33-1/4	16-1/2	6-1/8	68	0.063	0.03	21-1/2 x 21-1/2	5ACC24FS	5ACC24FT	5ACC05SC	5ACC19SD
5ADS18EA	18	30	36	18-3/4	7-1/2	86	0.063	0.03	25-1/2 x 25-1/2	5ACC28FS	5ACC28FT	5ACC05SC	5ACC23SD
5ADS18GB	18	30	36	18-3/4	7-1/2	96	0.063	0.03	25-1/2 x 25-1/2	5ACC28FS	5ACC28FT	—	5ACC23SD
5ADS20DB	20	34	38-3/4	18-3/4	7-1/2	128	0.063	0.03	29-1/2 x 29-1/2	5ACC32FS	5ACC32FT	5ACC05SC	5ACC27SD
5ADS20GB	20	34	38-3/4	18-3/4	7-1/2	128	0.063	0.03	29-1/2 x 29-1/2	5ACC32FS	5ACC32FT	—	5ACC27SD
5ADS24DB	24	34	45	18-3/4	7-1/2	140	0.063	0.03	29-1/2 x 29-1/2	5ACC32FS	5ACC32FT	5ACC10SC	5ACC27SD
5ADS24FB	24	34	45	18-3/4	7-1/2	140	0.063	0.03	29-1/2 x 29-1/2	5ACC32FS	5ACC32FT	—	5ACC27SD

Axial Ventilators

Direct-Drive Axial Supply Downblast Roof Ventilators

Model No.	HP	RPM	TS (FPM)	Max. BHP	Volts	0.0" SP	0.125" SP	0.250" SP	0.375" SP	0.500" SP	0.625" SP	0.750" SP	0.875" SP	1.00" SP
					Max. Op. Amps	CFM	CFM	CFM	CFM	CFM	CFM	CFM	CFM	CFM
					Sones†	Sones†	Sones†	Sones†	Sones†	Sones†	Sones†	Sones†	Sones†	
5ADS12AA	1/6	1775	5576	0.13	115	942	789	579	284					
					1.65	9.2	8.8	8.9	10.5					
5ADS12BA	1/4	1758	5523	0.23	115	1372	1245	1073	916	484				
					2.69	18.6	17.9	18.5	18.9	19.3				
5ADS14BA	1/4	1755	5513	0.26	115	1809	1648	1443	1134	794	420			
					2.71	17.9	17.1	17.4	17.9	18.4	18.6			
5ADS14EA	3/4	1733	6352	0.53	115	2526	2230	1947	1624	1278	612			
					4.25	17.4	17.2	17.0	17.3	17.5	18.6			
5ADS16EAW	3/4	1763	7385	0.35	115	2274	2080	1851	1593	1339	1027	690	207	
					4.44	19.2	18.5	17.9	18.2	18.4	17.5	16.6	—	
5ADS16EAY	3/4	1709	7158	0.59	115	2827	2597	2371	2095	1832	1353	550		
					4.94	22	22	22	22	22	21	20		
5ADS18EA	3/4	1695	7987	0.75	115	3766	3338	3041	2719	2314	1812	1250		
					6.12	28	28	27	26	25	23	22		
5ADS18GB	1 1/2	1734	8171	0.99	115/230	4074	3932	3735	3482	2950	2466	1718		
					9.9/5.0	30	30	29	28	27	26	24		
5ADS20DB	1/2	1108	5801	0.56	115/230	3592	3234	2861	2409	1345	600			
					6.1/3.0	19.0	18.0	17.0	18.0	16.0	15.0			
5ADS20GB	1 1/2	1706	8932	1.4	115/230	5322	5006	4650	4254	3804	3252	2521		
					13.7/6.9	43	43	43	38	33	—	—		
5ADS24DB	1/2	1122	7050	0.55	115/230	4731	4196	3564	2768	1990	1101	180		
					4.8/2.4	24	23	22	20	18.0	19.0	21		
5ADS24FB	1	1091	6855	0.92	115/230	5909	5373	4661	3924	3026	1573			
					13.2/6.6	28	26	25	23	21	23			

Performance certified is for installation type A: Free Inlet, Free Outlet. Performance ratings include the effects of bird screens. Speed (RPM) shown is nominal, and performance shown is based on actual speed of test.

† The sound ratings are loudness values in fan sones at 5 ft. (1.5m) in a hemispherical free field calculated per AMCA standard 301. Values shown are for Installation Type A, Free Outlet hemispherical sone levels.

Typical Specifications:

Direct-Drive Axial Supply Roof Ventilators

Roof mount supply fans shall be axial downblast direct-drive type. Propeller shall be constructed of a steel hub with galvalum or aluminum blades. Propellers shall be statically and dynamically balanced. The fan housing shall be constructed of heavy gauge aluminum with a rigid steel support structure. Baffles and motor compartment hoods shall have a rolled bead for added strength. Motors shall be readily accessible for maintenance. A junction box shall be factory installed to permit a disconnect switch to be wired to the fan motor within the motor compartment. A conduit chase shall be provided through the curb cap to the motor compartment for ease of electrical wiring. All fans shall bear the AMCA Certified Ratings Seal for sound and air performance. Each fan shall bear a permanently affixed manufacturer's nameplate containing model number and carry a one-year warranty. Fans shall be Fantech Model Direct-Drive Axial Supply Downblast Roof Ventilators as manufactured by Systemair Mfg. Inc., Lenexa, Kansas.

Axial Ventilators

Belt-Drive Axial Exhaust Downblast Roof Ventilators

Belt-drive downblast fans are designed for use in applications requiring the steady exhaust of air under low to moderate static pressures.

Agency Listing

- All ventilators are UL Standard 705 listed
- Ventilators are CSA listed according to Standard C22.2 No. 113-M1984 (Fans & Ventilators)

Features and Specifications

- Motor and drive are located outside discharge air stream and cooled by outside air
- Durable spun aluminum housing and galvanized steel base with 5 and 6 stamped steel blade designs
- Ball-bearing motor and drives are packed separately when ordering ventilators with drive packages
- Permanently lubricated maintenance-free bearings are factory-installed on fan shaft
- Externally cooled motor compartment

- Motors are 115V or 115/230V, 60 Hz, ball bearing motors with Class B insulation
- Maximum inlet temperature is 140°F
- Built-in bird screen to protect discharge and ensure safe, obstruction-free operation
- Motor and propeller are easily detachable without removing ventilator from curb
- Junction box mounted in motor compartment
- Windband rolled bead for added strength and easy maneuverability
- Welded curb cap corners eliminate water entry into ducts or building

Accessories (available separately)

- For more information, see Power Roof Ventilator Accessories
- Fixed mounting curbs.
- NEMA 1, NEMA 3R and NEMA 4 disconnect switches.
- Backdraft dampers.

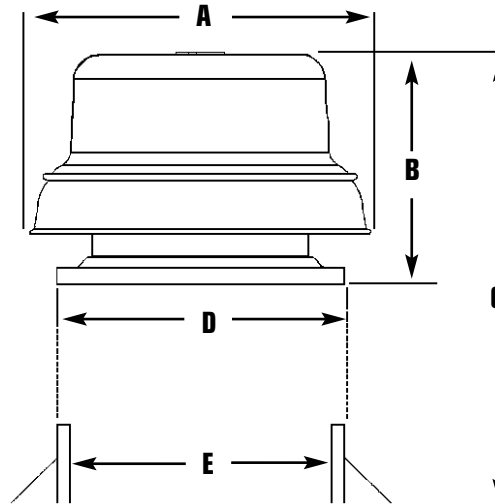

Fantech, Inc. and Systemair Mfg. Inc. certify that the Belt-Drive Axial Exhaust Downblast Roof Ventilators shown herein are licensed to bear the AMCA Seal. The ratings shown are based on tests and procedures performed in accordance with AMCA Publication 211 and comply with the requirements of the AMCA Certified Ratings Program.

Model No.	Fan Dia. (In.)	Dimensions (In.)					Total Ship Wt. (lbs.)	Gauge Thickness (In.)			Recommended Roof Opening (In.)	Backdraft Damper Model No.	Optional Accessories	
		A	B	C†	D	E		Venturi	Windband	Hood			8" Fixed Curb Model No.	12" Fixed Curb Model No.
5ABE18	18	32	23-1/4	31-1/4	26	21-1/2	67	0.063	0.063	0.08	21-1/2 x 21-1/2	5ACC19RD	5ACC24FS	5ACC24FT
5ABE24	24	40	25-5/8	33-5/8	34	29-1/2	90	0.063	0.08	0.08	25-1/2 x 25-1/2	5ACC27RD	5ACC32FS	5ACC32FT
5ABE30	30	48	31-1/2	39-1/2	42	37-1/2	145	0.063	0.08	0.08	37-1/2 x 37-1/2	5ACC35RD	5ACC40FS	5ACC40FT
5ABE36	36	57	33	41	46	41-1/2	55	0.063	0.09	0.08	43-1/2 x 43-1/2	5ACC39RD	5ACC44FS	5ACC44FT

† Add 4" when using 12" curb.

Axial Ventilators

Belt-Drive Axial Exhaust Downblast Roof Ventilators

Model No.	HP	RPM	TS (FPM)	Max. BHP†	0.0" SP	0.125" SP	0.250" SP	0.375" SP	0.500" SP	1-Phase Motor 115/230V, 60 Hz	3-Phase Motor 230/460V, 60 Hz
										Total Ship Wt. (lbs.)	Total Ship Wt. (lbs.)
5ABE18	1/6	905	4265	0.22	2023	1837	1562	1299	915	5ABE18AB	—
										85	—
	1/4	1010	4759	0.30	2258	2093	1871	1632	1359	5ABE18BB	5ABE18BF
										89	89
	1/3	1180	5560	0.45	2638	2500	2350	2124	1924	5ABE18CB	5ABE18CF
										90	90
	1/2	1300	6126	0.60	2906	2784	2648	2474	2266	5ABE18DB	5ABE18DF
										92	92
5ABE24	1/4	635	3990	0.31	3400	2863	2116	1323	—	5ABE24BB	5ABE24BF
										112	112
	1/3	685	4304	0.38	3667	3162	2475	1785	1123	5ABE24CB	5ABE24CF
										113	113
	1/2	785	4932	0.56	4203	3749	3198	2645	2002	5ABE24DB	5ABE24DF
										115	115
	3/4	900	5655	0.85	4818	4425	4061	3454	3007	5ABE24EB	5ABE24EF
										117	117
	1	1020	6409	1.23	5461	5116	4774	4367	3857	5ABE24FB	5ABE24FF
										122	118
5ABE30	1/2	620	4869	0.59	5609	4872	3826	2947	2035	5ABE30DB	5ABE30DF
										170	169
	3/4	720	5655	0.86	6514	5906	5112	4221	3459	5ABE30EB	5ABE30EF
										172	171
	1	775	6087	1.13	7012	6464	5754	4872	4185	5ABE30FB	5ABE30FF
										177	172
	1 1/2	890	6990	1.71	8052	7604	7029	6358	5568	5ABE30GB	5ABE30GF
										193	189
	2	985	7736	2.40	8912	8497	8013	7456	6813	5ABE30HB	5ABE30HF
										204	190
5ABE36	3/4	550	5183	0.92	8787	7784	6450	4966	3798	5ABE36EB	5ABE36EF
										282	281
	1	610	5749	1.26	9745	8877	7777	6340	5206	5ABE36FB	5ABE36FF
										287	282
	1 1/2	670	6314	1.66	10705	9915	8973	7817	6451	5ABE36GB	5ABE36GF
										303	299

Performance certified is for installation type A: Free Inlet, Free Outlet. Performance rating includes the effects of bird screens.

† Power ratings (BHP) do not include transmission losses.

Typical Specifications:

Belt-Drive Axial Downblast Roof Ventilators

Roof mount exhaust fans shall be axial downblast belt-drive type. Propeller shall be constructed of steel (18" propeller is constructed of a steel hub and aluminum blades). Propellers shall be statically balanced. The fan housing shall be constructed of heavy gauge aluminum with a rigid steel support structure. Baffles and motor compartment hoods shall have a rolled bead for added strength. Motors shall be mounted out of the airstream. Fresh air for motor cooling shall be drawn into the motor compartment from an area free of discharge contaminants. Motors shall be readily accessible for maintenance. Steel shafts shall be turned, ground-polished and mounted in permanently sealed and lubricated ball bearings. Bearings shall be selected for a minimum life (L50) in excess of 200,000 hours at maximum cataloged operating speed. Drives shall be sized for a minimum of 150% of driven horsepower. Pulleys shall be fully machined, cast iron type, keyed and securely attached to the fan and motor shafts. A junction box shall be factory installed to permit a disconnect switch to be wired to the fan motor within the motor compartment. A conduit chase shall be provided through the curb cap to the motor compartment for ease of electrical wiring. All fans shall bear the AMCA Certified Ratings Seal for sound and air performance. Each fan shall bear a permanently affixed manufacturer's nameplate containing model number and carry a one-year warranty. Fans shall be Fantech Model Belt-Drive Axial Exhaust Downblast Roof Ventilators as manufactured by Systemair Mfg. Inc., Lenexa, Kansas.

Axial Ventilators

Hooded Axial Belt-Drive Exhaust Rooftop Ventilators

Roof-mounted ventilators are designed for use in factories, warehouses, laundries, etc.

Features and Specifications

- Galvanized steel hood and side panels
- Steel blades (5-wing) are statically balanced
- Easy to assemble. Side panels bolt together. Fan mounts on heavy gauge flanges on inside of side panels. Adjustable motor mount for ease of belt tensioning. Pre-assembled top (including bird screen) hinges to side panels
- Unit is weathertight when fully assembled and latched (latches have provisions for locks)

- Air deliveries up to 25,455 CFM. Maximum inlet temperature is 120°F
- Heavy-duty, 1725 RPM, ball-bearing motors feature an easy-access motor terminal box
- Housing, fan and drive package are shipped separately
- Fans feature self-aligning pillow-block bearings and cast iron sheaves

Accessories (available separately)

- For more information, see Power Roof Ventilator Accessories
- Fixed mounting curbs.
- NEMA 1, NEMA 3R and NEMA 4 disconnect switches.
- Backdraft dampers.

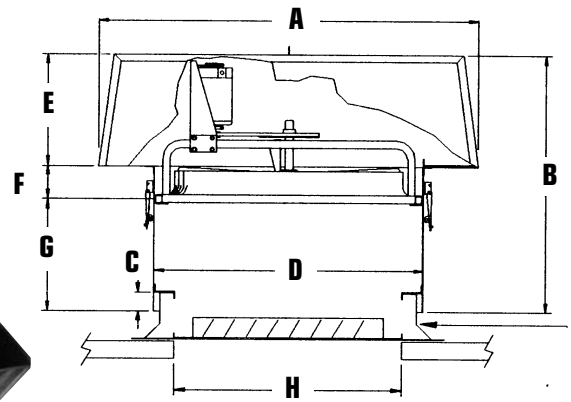

Illustrated completely assembled; hood and base assembly shipped as separate components

Model No.	Fan Dia. (In.)	Dimensions (In.)								Ship Wt. (lbs.) (less motor assembly)	Hood Only Model No.	Optional Accessories		
		A	B	C	D	E	F	G	H			8" Ht. Model No.	12" Ht. Model No.	Gravity Backdraft Dampers Model No.
1RHE24	24	46-1/2	38	2-1/2	28-1/2	15	8-1/2	14-1/2	19-1/2	210	1RFH24	5ACC27FS	5ACC27FT	5ACC19RD
1RHE30	30	55-1/2	37	2-1/2	34-1/2	15	7-1/2	14-1/2	27-1/2	240	1RFH30	5ACC33FS	5ACC33FT	5ACC27RD
1RHE36	36	64-1/2	37	2-1/2	40-1/2	15	7-1/2	14-1/2	30-1/2	300	1RFH36	5ACC39FS	5ACC39FT	5ACC30RD
1RHE42	42	74-1/2	39-1/2	2-1/2	46-1/2	15	10	14-1/2	39-1/2	370	1RFH42	5ACC45FS	5ACC45FT	5ACC39RD
1RHE48	48	86	41-1/2	2-1/2	54-1/2	15	12	14-1/2	48-1/2	460	1RFH48	5ACC53FS	5ACC53FT	5ACC48RD

+ Use 12" curb with motorized damper.

Typical Specifications:

Hooded Rooftop Axial Belt-Drive Exhaust

Roof mount exhaust fans shall be axial downblast belt-drive type. The propeller shall be constructed of steel. Propellers shall be statically balanced. The hood and side panels shall be constructed of galvanized steel with a rigid steel support structure. The fan housing shall be constructed of steel with a rigid steel support structure and coated with a durable, baked-on polyester powder coat finish. Motors shall be readily accessible for maintenance. Steel shafts shall be turned, ground-polished and mounted in permanently sealed and lubricated ball bearings. Bearings shall be selected for a minimum life (L50) in excess of 200,000 hours at maximum cataloged operating speed. Drives shall be sized for a minimum of 150% of driven horsepower. Pulleys shall be fully machined, cast iron type, keyed and securely attached to the fan and motor shafts. Each fan shall bear a permanently affixed manufacturer's nameplate containing model number and carry a one-year warranty. Fans shall be Fantech Model Hooded Axial Belt-Drive Exhaust Rooftop Ventilators as manufactured by Systemair Mfg. Inc., Lenexa, Kansas.

Axial Ventilators

Hooded Axial Belt-Drive Exhaust Rooftop Ventilators

Model No.	HP	RPM	TS (FPM)	0.0" SP CFM	0.125" SP CFM	0.250" SP CFM	0.375" SP CFM	Dripproof Capacitor Start Motor 115/230V, 60 Hz	Totally Enclosed Capacitor Start Motor 115/230V, 60 Hz	Totally Enclosed 3-Phase Motor 208-220/440V, 60 Hz
								Total Ship Wt. (lbs.)	Total Ship Wt. (lbs.)	Total Ship Wt. (lbs.)
1RHE24	1/4	650	4084	5120	4195	2160	—	1RHE24BB*	1RHE24B2	1RHE24BY
								265	268	267
	1/3	710	4461	5595	4775	2830	1650	1RHE24CB*	1RHE24C2	1RHE24CY
								268	271	268
	1/2	835	5246	6580	5910	4970	3100	1RHE24DB	1RHE24D2	1RHE24DY
								270	274	272
	3/4	945	5937	7445	6870	6200	4800	1RHE24EB	1RHE24E2	1RHE24EY
								275	279	275
1RHE30	1/4	470	3691	6895	4950	—	—	1RHE30BB*	1RHE30B2**	1RHE30BY
								306	309	308
	1/3	500	3927	7335	5605	2320	—	1RHE30CB*	1RHE30C2**	1RHE30CY
								309	312	309
	1/2	585	4594	8585	7305	4750	—	1RHE30DB	1RHE30D2**	1RHE30DY
								311	315	313
	3/4	670	5262	9830	8805	7120	4130	1RHE30EB	1RHE30E2**	1RHE30EY
								316	320	316
	1	720	5655	10565	9615	8205	5945	1RHE30FB	1RHE30F2**	1RHE30FY
								323	329	322
1RHE36	1/3	415	3911	10160	7590	—	—	1RHE36CB*	1RHE36C2**	1RHE36CY
								379	382	379
	1/2	485	4571	11875	9915	5045	—	1RHE36DB	1RHE36D2**	1RHE36DY
								381	385	383
	3/4	540	5089	13220	11490	8565	4215	1RHE36EB	1RHE36E2**	1RHE36EY
								386	390	386
	1	605	5702	14815	13300	11415	6600	1RHE36FB	1RHE36F2**	1RHE36FY
								393	399	392
1 1/2	660	6220	16160	14805	13215	10400	1RHE36GB	1RHE36G2	1RHE36GY	
							399	403	396	
1RHE42	1/2	380	4178	14515	11040	—	—	1RHE42DB	1RHE42D2**	1RHE42DY
								462	469	464
	3/4	430	4278	16425	13670	6645	—	1RHE42EB	1RHE42E2**	1RHE42EY
								467	471	467
	1	460	5058	17570	15045	8350	4855	1RHE42FB	1RHE42F2**	1RHE42FY
								474	480	473
	1 1/2	535	5882	20435	18345	15480	8530	1RHE42GB	1RHE42G2	1RHE42GY
								480	484	477
1RHE48	1/2	315	3958	17060	10790	—	—	1RHE48DB	1RHE48D2	1RHE48DY
								568	572	570
	3/4	370	4649	20040	15900	6450	—	1RHE48EB	1RHE48E2	1RHE48EY
								573	577	573
	1	400	5026	21665	18120	8860	3465	1RHE48FB	1RHE48F2	1RHE48FY
								580	586	579
	1 1/2	450	5655	24375	21345	15700	7640	1RHE48GB	1RHE48G2	1RHE48GY
								586	590	583
	2	470	5906	25455	22575	17615	9275	1RHE48HB	1RHE48H2	1RHE48HY†
								603	616	612

* 115V, 60 Hz only. † 230/460V, 60 Hz only. # TENV, 115/230V, 60 Hz, split phase motor. ** Auto reset thermal protection

Axial Ventilators

Hooded Axial Belt-Drive Supply Rooftop Ventilators

Roof-mounted ventilators are designed for use in factories, warehouses, laundries, etc.

Features and Specifications

- Galvanized steel hood and side panels
- Steel blades (5-wing) are statically balanced (8-wing on reversible)
- Easy to assemble. Side panels bolt together. Fan mounts on heavy gauge flanges on inside of side panels. Adjustable motor mount for ease of belt tensioning. Pre-assembled top (including bird screen) hinges to side panels
- Unit is weathertight when fully assembled and latched (latches have provisions for locks)
- Air deliveries up to 21,035 CFM. Maximum inlet temperature is 120°F

- Heavy-duty, 1725 RPM, ball-bearing motors feature an easy-access motor terminal box
- Fans feature self-aligning pillow-block bearings and cast iron sheaves

Accessories (available separately)

- For more information, see Power Roof Ventilator Accessories
- Fixed and adjustable mounting curbs.
- NEMA 1, NEMA 3R and NEMA 4 disconnect switches.
- Backdraft dampers.

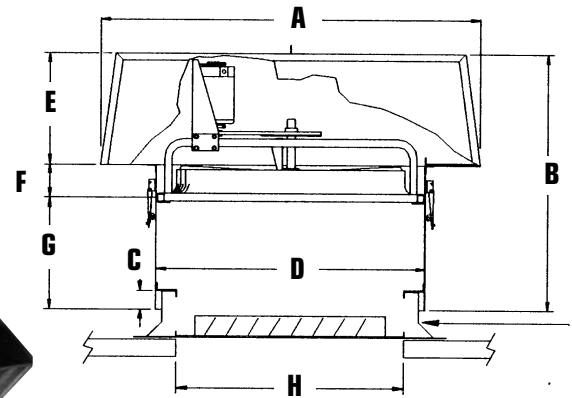
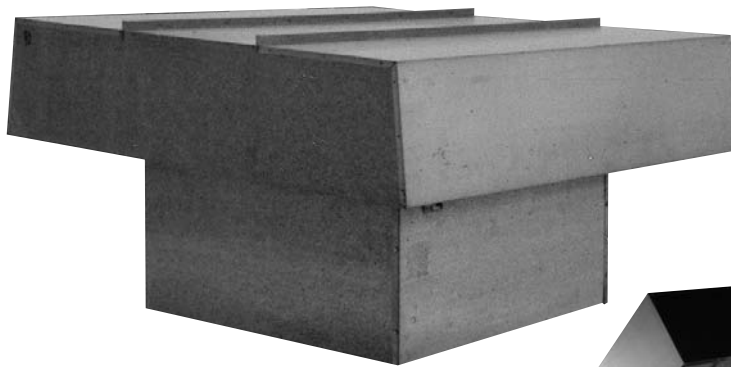

Illustrated completely assembled; hood and base assembly shipped as separate components

Model No.	Fan Dia. (In.)	Dimensions (In.)								Ship Wt. (lbs.) (less motor assembly)	Hood Only Model No.	Optional Accessories		
		A	B	C	D	E	F	G	H			8" Ht. Model No.	12" Ht. Model No.	Gravity Dampers+ Model No.
1RHS24	24	46-1/2	38	2-1/2	28-1/2	15	8-1/2	14-1/2	19-1/2	210	1RFH24	5ACC27FS	5ACC27FT	5ACC19SD
1RHS30	30	55-1/2	37	2-1/2	34-1/2	15	7-1/2	14-1/2	27-1/2	240	1RFH30	5ACC33FS	5ACC33FT	5ACC27SD
1RHS36	36	64-1/2	37	2-1/2	40-1/2	15	7-1/2	14-1/2	30-1/2	300	1RFH36	5ACC39FS	5ACC39FT	5ACC30SD
1RHS42	42	74-1/2	39-1/2	2-1/2	46-1/2	15	10	14-1/2	39-1/2	370	1RFH42	5ACC45FS	5ACC45FT	5ACC39SD
1RHS48	48	86	41-1/2	2-1/2	54-1/2	15	12	14-1/2	48-1/2	460	1RFH48	5ACC53FS	5ACC53FT	5ACC48SD

+ Use 12" curb with motorized damper.

Typical Specifications:

Hooded Rooftop Axial Belt-Drive Supply

Roof mount supply fans shall be axial downblast belt-drive type. The propeller shall be constructed of steel. Propellers shall be statically balanced. The hood and side panels shall be constructed of galvanized steel with a rigid steel support structure. The fan housing shall be constructed of steel with a rigid steel support structure and coated with a durable, baked-on polyester powder coat finish. Motors shall be readily accessible for maintenance. Steel shafts shall be turned, ground-polished and mounted in permanently sealed and lubricated ball bearings. Bearings shall be selected for a minimum life (L50) in excess of 200,000 hours at maximum cataloged operating speed. Drives shall be sized for a minimum of 150% of driven horsepower. Pulleys shall be fully machined, cast iron type, keyed and securely attached to the fan and motor shafts. Each fan shall bear a permanently affixed manufacturer's nameplate containing model number and carry a one-year warranty. Fans shall be Fantech Model Hooded Axial Belt-Drive Supply Rooftop Ventilators as manufactured by Systemair Mfg. Inc., Lenexa, Kansas.

Axial Ventilators

Hooded Axial Belt-Drive Supply Rooftop Ventilators

Model No.	HP	RPM	TS (FPM)	0.0" SP CFM	0.125" SP CFM	0.250" SP CFM	0.375" SP CFM	Dripproof Capacitor Start Motor 115/230V, 60 Hz	Totally Enclosed Capacitor Start Motor 115/230V, 60 Hz	Totally Enclosed 3-Phase Motor 208-220/440V, 60 Hz
								Total Ship Wt. (lbs.)	Total Ship Wt. (lbs.)	Total Ship Wt. (lbs.)
1RHS24	1/4	650	4084	4661	3661	2325	—	1RHS24BB*	1RHS24B2	1RHS24BY
								265	268	267
	1/3	710	4461	5091	4181	2872	2058	1RHS24CB*	1RHS24C2	1RHS24CY
								268	271	268
	1/2	835	5246	5988	5224	4386	3138	1RHS24DB#	1RHS24D2	1RHS24DY
								270	274	272
	3/4	945	5937	6777	6102	5403	4454	1RHS24EB	1RHS24E2	1RHS24EY
								275	279	275
1RHS30	1/4	470	3691	6107	3958	—	—	1RHS30BB*	1RHS30B2**	1RHS30BY
								306	309	308
	1/3	500	3927	6497	4559	2572	—	1RHS30CB*	1RHS30C2**	1RHS30CY
								309	312	309
	1/2	585	4594	7602	6168	4087	2616	1RHS30DB	1RHS30D2**	1RHS30DY
								311	315	313
	3/4	670	5262	8706	7536	5706	4206	1RHS30EB	1RHS30E2**	1RHS30EY
								316	320	316
	1	720	5655	9356	8267	6700	5065	1RHS30FB	1RHS30F2**	1RHS30FY
								323	329	322
1RHS36	1/3	415	3911	8889	5914	—	—	1RHS36CB*	1RHS36C2**	1RHS36CY
								379	382	379
	1/2	485	4571	10388	8050	4924	—	1RHS36DB	1RHS36D2**	1RHS36DY
								381	385	383
	3/4	540	5089	11566	9633	6832	4290	1RHS36EB	1RHS36E2**	1RHS36EY
								386	390	386
	1	605	5702	12959	11429	8935	6424	1RHS36FB	1RHS36F2**	1RHS36FY
								393	399	392
1 1/2	660	6220	14137	12783	10616	8322	1RHS36GB	1RHS36G2	1RHS36GY	
							399	403	396	
1RHS42	1/2	380	4178	12196	7543	—	—	1RHS42DB	1RHS42D2**	1RHS42DY
								462	469	464
	3/4	430	4728	13801	9884	5414	—	1RHS42EB	1RHS42E2**	1RHS42EY
								467	471	467
	1	460	5058	14763	11144	6727	3767	1RHS42FB	1RHS42F2**	1RHS42FY
								474	480	473
1 1/2	535	5882	17170	14069	10550	6962	1RHS42GB	1RHS42G2	1RHS42GY	
							480	484	477	
1RHS48	1/2	315	3958	14098	7381	—	—	1RHS48DB	1RHS48D2	1RHS48DY
								568	572	570
	3/4	370	4649	16560	10576	5319	—	1RHS48EB	1RHS48E2	1RHS48EY
								573	577	573
	1	400	5026	17902	12389	7574	2056	1RHS48FB	1RHS48F2	1RHS48FY
								580	586	579
	1 1/2	450	5655	20140	15274	10713	6263	1RHS48GB	1RHS48G2	1RHS48GY
								586	590	583
	2	470	5906	21035	16390	11906	7835	1RHS48HB	1RHS48H2	1RHS48HY†
								603	616	612

* 115V, 60 Hz only. † 230/460V, 60 Hz only. # TENV, 115/230V, 60 Hz, split phase motor. ** Auto reset thermal protection

Axial Ventilators

Axial Belt-Drive Upblast Exhaust Ventilators

Axial belt-drive upblast ventilators are designed for use in industrial/commercial buildings, foundries, laboratories, machine shops and warehouses.

Ventilator Construction

- High exhaust velocity opens butterfly damper
- The butterfly dampers feature a magnetic seal and rolled edges to reduce entrance of weather into facility when the ventilator is not in operation
- Housing, windband and base are galvanized steel construction
- Statically balanced steel propeller

- Permanently lubricated, maintenance-free bearings factory-installed on sizes 24" - 48"
- Regreaseable, pillow-block bearings factory-installed on sizes 54" - 60"

Accessories (available separately)

- For more information, see Power Roof Ventilator Accessories
- Fixed mounting curbs.
- NEMA 1, NEMA 3R and NEMA 4 disconnect switches.

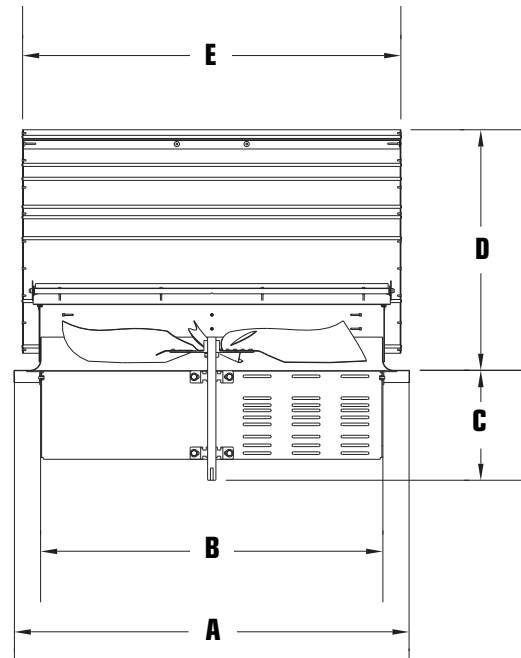

Fantech, Inc. and Systemair Mfg. Inc. certify that the Axial Belt-Drive Upblast Exhaust Ventilators shown herein are licensed to bear the AMCA Seal. The ratings shown are based on tests and procedures performed in accordance with AMCA Publication 211 and AMCA Publication 311 and comply with the requirements of the AMCA Certified Ratings Program.

Model No.	Fan Dia. (In.)	Dimensions (In.)					Max Ship Wt. (lbs.)	Optional Accessories
		A	B	C	D	E		Roof Curb 12" Ht. Model No.
5BLT24	24	36	25	11-5/8	23-5/8	30	200	5ACC34FT
5BLT30	30	38-1/2	31	15	24-1/2	36	243	5ACC37FT
5BLT36	36	44-1/2	37	15	27-1/2	42	291	5ACC43FT
5BLT42	42	50-1/2	43	16	30-1/2	48	383	5ACC49FT
5BLT48	48	56-1/2	49	16	33-1/2	54	442	5ACC55FT
5BLT54	54	66-1/2	61	19	38	60-1/4	727	5ACC65FT
5BLT60	60	72-1/2	67	19	41	66-1/4	936	5ACC71FT

Typical Specifications:

Axial Belt-Drive Upblast

Roof mount exhaust fans shall be axial upblast belt-drive type. The propeller shall be constructed of steel. Propellers shall be statically balanced. The fan housing shall be constructed of galvanized steel with a rigid steel support structure. Motors shall be readily accessible for maintenance. Steel shafts shall be turned, ground-polished and mounted in permanently sealed and lubricated ball bearings (54" and 60" units feature regreaseable pillow block bearings). Bearings shall be selected for a minimum life (L50) in excess of 200,000 hours at maximum cataloged operating speed. Drives shall be sized for a minimum of 150% of driven horsepower. Pulleys shall be fully machined, cast iron type, keyed and securely attached to the fan and motor shafts. Each fan shall bear a permanently affixed manufacturer's nameplate containing model number and carry a one-year warranty. Fans shall be Fantech Model Axial Belt-Drive Upblast Exhaust Ventilators as manufactured by Systemair Mfg. Inc., Lenexa, Kansas.

Axial Ventilators

Axial Belt-Drive Upblast Exhaust Ventilators

Model No.	HP	RPM	TS (FPM)	Max BHP†	Sones@ 0.250" SP No.	0.0" SP CFM	0.125" SP CFM	0.250" SP CFM	0.375" SP CFM	0.500" SP CFM	Totally Enclosed 1-Phase Motor 115/208-230V, 60Hz		Totally Enclosed 3-Phase Motor 208-208-460V, 60Hz	
											Model No. Wt. (Lbs.)	Model No. Wt. (Lbs.)		
5BLT24	1/3	755	4744	0.36	13.0	4680	2400	1480	570	—	5BLT24C2	5BLT24CY		
											176	176		
	1/2	866	5441	0.55	17.0	5370	3212	2190	1420	—	5BLT24D2	5BLT24DY		
											178	178		
3/4	990	6220	0.82	20	6130	4700	2940	2230	1570	—	5BLT24E2	5BLT24EY		
											186	186		
1	1090	6848	1.10	25	6740	5520	3510	2860	2220	—	5BLT24F2	5BLT24FY		
											189	189		
5BLT30	3/4	700	5498	0.76	19.2	8100	7075	4330	—	—	5BLT30E2	5BLT30EY		
											216	216		
	1	777	6102	1.04	23	8990	8120	6620	4100	—	—	5BLT30F2	5BLT30FY	
												219	219	
1 1/2	875	6872	1.48	28	10120	9350	8350	5620	4460	—	5BLT30G2	5BLT30GY		
											230	230		
2	972	7634	2.03	33	11240	10550	9750	8530	5790	—	5BLT30H2	5BLT30HY		
											243	245		
5BLT36	3/4	510	4807	0.78	17.5	10960	8960	5510	—	—	5BLT36E2	5BLT36EY		
											261	261		
	1	560	5278	1.11	20	12035	10280	6630	4860	—	—	5BLT36F2	5BLT36FY	
												264	264	
1 1/2	647	6098	1.71	25	13905	12505	10240	7260	5630	—	5BLT36G2	5BLT36GY		
											274	274		
2	700	6597	2.03	29	15040	13750	12100	8430	7200	—	5BLT36H2	5BLT36HY		
											288	290		
5BLT42	1 1/2	466	5124	1.60	19.1	16920	14790	8370	—	—	5BLT42G2	5BLT42GY		
											340	274		
	2	510	5608	2.12	24	18510	16650	14070	8080	—	—	5BLT42H2	5BLT42HY	
												353	355	
3	588	6465	3.23	32	21340	19740	17820	15250	9300	—	—	5BLT42JY		
											—	379		
5	700	7697	5.46	43	25410	24060	22660	20920	18760	—	—	5BLT42KY		
											—	400		
5BLT48	1 1/2	378	4750	1.50	18.8	19920	16360	8140	—	—	5BLT48G2	5BLT48GY		
											399	399		
	2	437	5492	2.32	24	23030	20130	11665	5520	—	—	5BLT48H2	5BLT48HY	
												413	415	
3	498	6258	3.43	30	26250	23825	20510	12060	9370	—	—	5BLT48JY		
											—	424		
5	588	7389	5.65	40	30990	28940	26580	23290	14680	—	—	5BLT48KY		
											—	439		
5BLT54	2	385	5443	2.21	23	25040	21990	12095	8880	5810	5BLT54H2	5BLT54HY		
											633	635		
	3	435	6149	3.17	27	28290	25620	19890	12030	9620	—	5BLT54J2	5BLT54JY	
												663	644	
5	515	7280	5.26	33	33500	31240	28240	20520	14665	—	5BLT54K2	5BLT54KY		
											681	659		
7 1/2	590	8341	7.58	41	38380	36410	34435	31000	21820	—	5BLT54L2	5BLT54LY		
											716	685		
5BLT60	3	372	5843	3.09	27	34200	30270	23730	13400	9420	5BLT60J2	5BLT60JY		
											868	849		
	5	440	6911	5.15	35	40460	37180	33090	21360	16480	—	5BLT60K2	5BLT60KY	
												886	864	
7 1/2	502	7885	7.77	44	46160	43285	40140	36180	23870	—	5BLT60L2	5BLT60LY		
											921	890		
10	555	8718	10.50	51	51030	48430	45835	42390	38685	—	—	5BLT60MY		
											—	905		

Performance certified is for installation type A: Free Inlet, Free Outlet. Performance ratings do not include the effects of bird screen.

† Power ratings (BHP) do not include transmission losses.

The sound ratings shown are loudness values in fan sones at 5 ft. (1.5m) in a hemispherical free field calculated per AMCA Standard 301. Values shown are for Installation Type A, Free Inlet hemispherical sone levels.

Axial Ventilators

Hooded Axial Belt-Drive Reversible Rooftop Ventilators

Roof-mounted ventilators are designed for use in factories, warehouses, laundries, etc.

Features and Specifications

- Galvanized steel hood and side panels
- Steel blades (5-wing) are statically balanced (8-wing on reversible)
- Easy to assemble. Side panels bolt together. Fan mounts on heavy gauge flanges on inside of side panels. Adjustable motor mount for ease of belt tensioning. Pre-assembled top (including bird screen) hinges to side panels
- Unit is weathertight when fully assembled and latched (latches have provisions for locks)

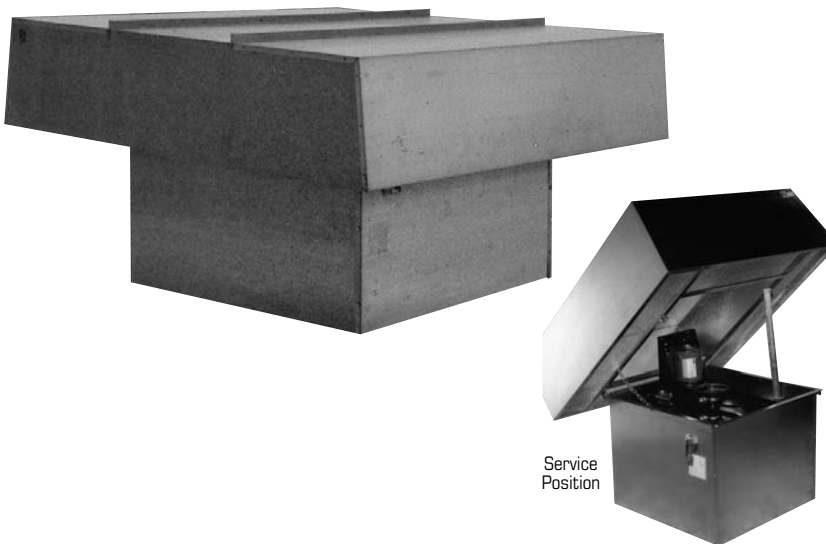

- Air deliveries up to 14,490 CFM. Maximum inlet temperature is 120°F
- Heavy-duty, 1725 RPM, ball-bearing motors feature an easy-access motor terminal box
- Fans feature self-aligning pillow-block bearings and cast iron sheaves

Accessories (available separately)

- For more information, see Power Roof Ventilator Accessories
- Fixed mounting curbs.
- NEMA 1, NEMA 3R and NEMA 4 disconnect switches.
- Backdraft dampers.

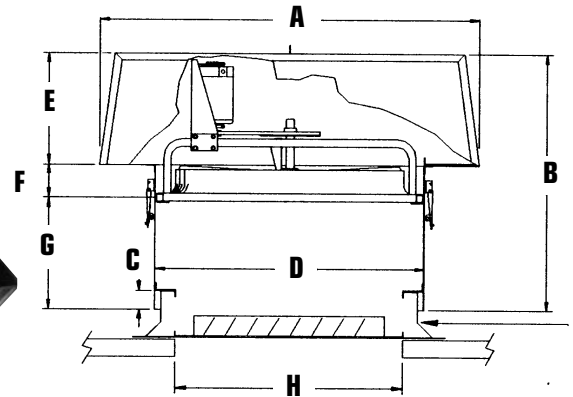

Illustrated completely assembled; hood and base assembly shipped as separate components

Model No.	Fan Dia. (In.)	Dimensions (In.)								Ship Wt. (lbs.) (less motor assembly)	Hood Only Model No.	Optional Accessories		
		A	B	C	D	E	F	G	H			8" Ht. Model No.	12" Ht. Model No.	Motorized Dampers+ Model No.
1RHR36	36	64-1/2	37	2-1/2	40-1/2	15	7-1/2	14-1/2	37	300	1RFH36	5ACC39FS	5ACC39FT	1ACC36MD

+ Use 12" curb with motorized damper:

Model No.	HP	RPM	TS (FPM)	0.0" SP CFM	0.125" SP CFM	0.250" SP CFM	0.375" SP CFM	Dripproof Capacitor Start Motor 115/230, 60 Hz		Totally Enclosed Capacitor Start Motor 115/230, 60 Hz		Totally Enclosed 3-Phase Motor 208-220/440V, 60 Hz	
								Total Ship Wt. (Lbs.)	Total Ship Wt. (Lbs.)	Total Ship Wt. (Lbs.)	Total Ship Wt. (Lbs.)		
1RHR36	1/2	490	4618	9360	7340	5720	4050	1RHR36DB 386	1RHR36D2 386	1RHR36DY 386			
	3/4	575	5419	10580	8910	7380	5940	1RHR36EB 389	1RHR36E2 389	1RHR36EY 389			
	1	650	6126	11700	10220	8690	7560	1RHR36FB 390	1RHR36F2** 390	1RHR36FY 390			
	1 1/2	765	7210	13140	11930	10490	9450	1RHR36GB 400	1RHR36G2 400	1RHR36GY 400			
	2	830	7822	14490	13410	12150	10800	1RHR36HB 406	1RHR36H2 406	1RHR36HY† 406			

† 230/460V, 60 Hz only. ** Auto reset thermal protection

Typical Specifications:

Hooded Rooftop Axial Belt-Drive Reversible: Roof mount reversible fans shall be axial downblast belt-drive type. The propeller shall be constructed of steel. Propellers shall be statically balanced. The hood and side panels shall be constructed of galvanized steel with a rigid steel support structure. The fan housing shall be constructed of steel with a rigid steel support structure and coated with a durable, baked-on polyester powder coat finish. Motors shall be readily accessible for maintenance. Steel shafts shall be turned, ground-polished and mounted in permanently sealed and lubricated ball bearings. Bearings shall be selected for a minimum life (L50) in excess of 200,000 hours at maximum cataloged operating speed. Drives shall be sized for a minimum of 150% of driven horsepower. Pulleys shall be fully machined, cast iron type, keyed and securely attached to the fan and motor shafts. Each fan shall bear a permanently affixed manufacturer's nameplate containing model number and carry a one-year warranty. Fans shall be Fantech Model Hooded Axial Belt-Drive Reversible Rooftop Ventilators as manufactured by Systemair Mfg. Inc., Lenexa, Kansas.

Power Roof Ventilator

Power Roof Ventilator Accessories

NFPA96 Fixed Ventilated Curbs

Allows for quick ventilator installation and uniformity throughout the entire job. Each curb accepts several ventilator sizes. Curbs fit ventilators listed in table below.

Features and Specifications

- Galvanized steel ventilated curb designed for use in commercial kitchen applications
- Self-flashing design incorporates flat mounting flange for fastening directly to the roof deck
- Stamped louvers on curb sides provide ventilation to hot exhaust ducts to protect building and roof members
- Sturdy 16-gauge construction
- Top flange surface is 1-1/2" W; base mounting flange is 3 -1/2" W

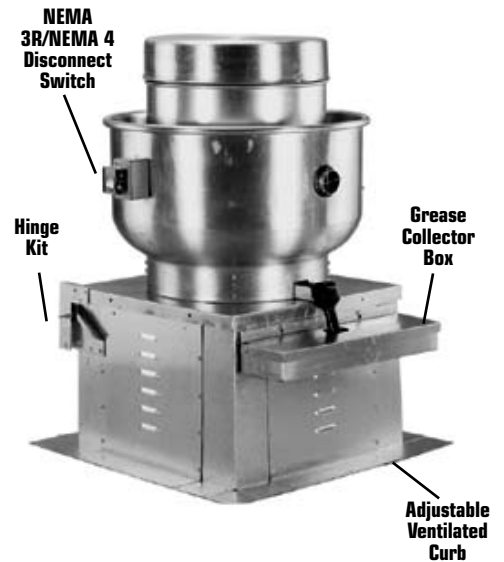

Fixed Ventilated Curbs

Model No.	Curb Height (in.)	Inside Sq. Dimensions (in.)	Outside Sq. Dimensions (in.)	Ship Wt. (Lbs.)
5ACC17VC	24	14-1/2	17-1/2	35
5ACC20VC	24	17-1/2	20-1/2	40
5ACC24VC	24	21-1/2	24-1/2	48
5ACC28VC	24	25-1/2	28-1/2	58
5ACC32VC	24	29-1/2	32-1/2	61
5ACC40VC	18	37-1/2	40-1/2	78
5ACC44VC	18	41-1/2	44-1/2	92



Fixed Curb

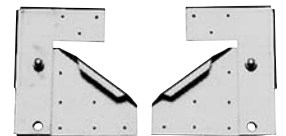

Hinge Kit

NFPA96 Grease Collector Box

The Grease Collector Box fastens to ventilator base. Easy to remove for cleaning. Diverts and traps heavy residual grease while protecting roof surface.

Grease Collector Box

Model No.	Length (in.)	Width (in.)	Height (in.) (less mounting flange)
5ACC00GC	14	5	4
5ACC01GC	24	7	5



Grease Collector Box

NFPA96 Hinge Kit

Model 5ACC00HK suitable for 10-1/2"-20" and model 5ACC01HK suitable for 24-1/2"-36." Allows entire fan to swing away for access to the wheel and ductwork.

Non-Reversing Manual Switches

Provides manual "On-Off" control of single or three phase AC motors where overload protection is not required or is provided separately.

Non-Reversing Manual Switches

Model No.	Enclosure Type	Number of Poles	Amps (Resistive)	Max. HP VAC			Dimensions (in.)			Ship Wt. (Lbs.)	
				115V	230V	460-575V	Enclosure Size	Depth (in.)	Width (in.)		Height (in.)
5ACC01MS	NEMA 1	2	30	2	2	3	Std.	2-3/4	2-7/16	4-1/4	0.8
5ACC02MS	NEMA 1	3	30	2	7.5	10	Std.	2-3/4	2-7/16	4-1/4	0.9
5ACC03MS	NEMA 3R	2	30	2	2	3	Std.	3	4-2/5	5-1/2	2
5ACC04MS	NEMA 3R	3	30	2	7.5	10	Std.	3	4-2/5	5-1/2	2
5ACC05MS	NEMA 4	2	30	2	2	3	Std.	4-1/4	3	4-1/4	2.9
5ACC06MS	NEMA 4	3	30	2	7.5	10	Std.	4-1/4	3	4-1/4	2.9

NEMA 1

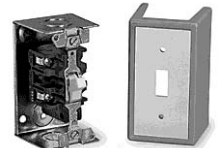

NEMA 3R



NEMA 4



Power Roof Ventilator

Power Roof Ventilator Accessories

Fixed Non-Ventilated Curbs

- Heavy gauge galvanized steel
- Corners are welded construction
- Canted surface accommodates roofing material up the side and over the top of the curb for a leak-proof installation
- Fiberglass insulation deadens sound and minimizes heat loss
- Shutter flanges included
- 1-1/2" Wood nailer included (fixed roof curbs only)

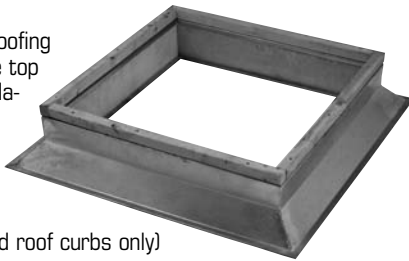

Fixed Roof Curbs					
Curb Sq. O.D. (In.)	Curb Sq. I.D. (In.)	8" Height		12" Height	
		Model No.	Shipping Weight	Model No.	Ship Wt. (Lbs.)
15	12	5ACC15FS	18	5ACC15FT	102
16-1/2	13-1/2	5ACC16FS	20	5ACC15FT	102
17-1/2	14-1/2	5ACC17FS	21	5ACC17FT	27
20-1/2	17-1/2	5ACC20FS	24	5ACC20FT	32
24-1/2	21-1/2	5ACC24FS	29	5ACC24FT	38
28-1/2	25-1/2	5ACC28FS	37	5ACC28FT	47
32-1/2	29-1/2	5ACC32FS	42	5ACC32FT	54
40-1/2	37-1/2	5ACC40FS	55	5ACC40FT	70
44-1/2	41-1/2	5ACC44FS	66	5ACC44FT	83
55-1/2	52-1/2	5ACC55FS	82	5ACC55FT	102

Curb Cap Adapters

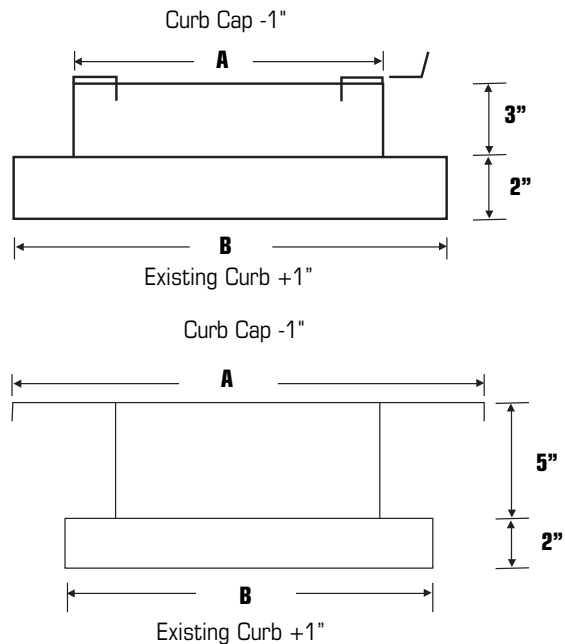
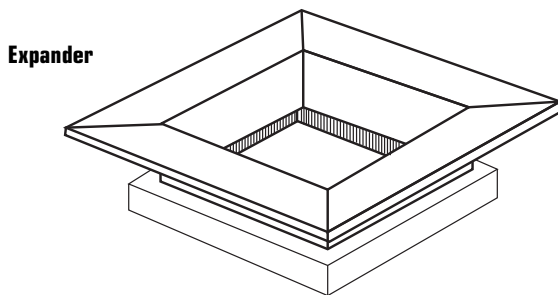
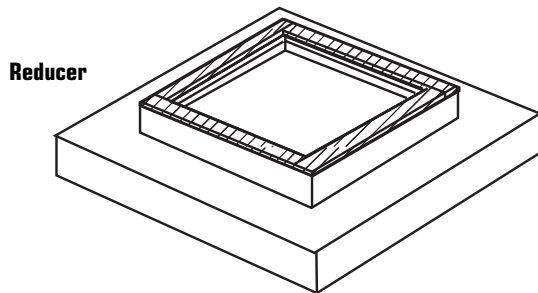

Power Roof Ventilator

Power Roof Ventilator Accessories

Variable Speed Controllers for UL 705 Applications

WARNING: Not for use with any kitchen exhaust application. Not for use in NFPA '96 applications.

- Variable speed controller permits adjustment of air movement from 100% to approximately 50%
- Rated 120V, 60 Hz
- Can be used to operate more than one fan, if the combined total amps do not exceed the control rating
- Controls are suitable and intended only for use with ventilators listed on pages 5, 27, 29, 53 and 55
- UL Listed when used in combination with ventilators listed on pages 5, 27, 29, 53 and 55



Speed Controller

Variable Speed Controllers for UL 705 Applications

Model No.	Max. AMPS	Ship Wt. (Lbs.)
5ACC03SC†	3.0	0.3
5ACC05SC†	5.0	0.3
5ACC06SC	6.0	0.3
5ACC10SC†	10.0	0.8

Used for multiple fan control with aggregate draw less than 3, 5, 6 or 10 amps, respectively.

† CSA-approved controllers.

Filters

- Specification – 60% average arrestance @ 350 FPM, 50% @ 70 FPM
- Minimum micron allowable – 10
- Rust-proof, corrosion-resistant filter media UL Class 2 filter requirement
- Meets ASHRAE 52-76 test conducted using a synthetic dust

Model No.	Filter Dimensions	No. of Filters Required by Model No.				
		5FSU10	5FSU12	5FSU15	5FSU18	5FSU20
5ACC01AF	25 x 17 x 0.88	—	1	1	—	—
5ACC02AF	25 x 20 x 0.88	—	1	1	—	—
5ACC03AF	28 x 20 x 0.88	1	—	—	—	—
5ACC04AF	30 x 20 x 0.88	—	—	—	1	—
5ACC05AF	30 x 23 x 0.88	—	—	—	1	—
5ACC06AF	35 x 25 x 0.88	—	—	—	—	2

Bird Screens

- Nickel-chrome plated for durability
- Concentric ring bird screen precisely sized to eliminate any rattling

Bird Screens		
Model No.	Dia. (In.)	Ship Wt. (Lbs.)
5ACC10BS	10-1/2	2.5 lbs.
5ACC12BS	12-1/4	2.5 lbs.
5ACC13BS	13-1/2	2.5 lbs.
5ACC15BS	15	3.0 lbs.
5ACC16BS	16-1/2	3.5 lbs.
5ACC18BS	18-1/4	3.5 lbs.
5ACC20BS	20	5.0 lbs.
5ACC24BS	24-1/4	5.0 lbs.
5ACC30BS	30	6.0 lbs.
5ACC36BS	36-1/2	13.0 lbs.

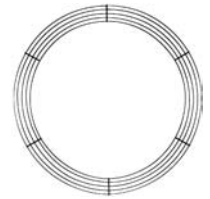

Bird Screen

Power Roof Ventilator

Power Roof Ventilator Accessories

Backdraft Dampers

For direct-drive and belt-drive centrifugal roof and wall ventilators. Blades open when ventilator comes on, close when airflow stops.

WARNING: Not for use with any kitchen exhaust application.

Wall Mount Dampers

- Extruded aluminum frame, 16-gauge
- Frame is 1- 1/2"; deep with 1- 3/8" flange
- Aluminum blades have felted edges for quiet operation
- Pre-punched mounting holes in frame
- Accessory Damper Motor—5ACCO5DM



Wall Damper

Roof Mount Dampers

- Galvanized 19-gauge steel frame
- Frame is 2" deep with 1" flange
- Aluminum blades have felted edges for quiet operation
- Pre-punched conduit hole knock-out
- Accessory Damper Motor—5ACCO4DM



Roof Damper

Wall Mount Backdraft Dampers

Wall Model No.	Damper Size (In.)	Outside Flange Dimension (In.)	Ship Wt. (Lbs.)	For Use with These Ventilator Model No. (UL 705 Only)	Recommended Wall Opening (In.)
5ACC08WD	8 x 8"	10-3/4 x 10-3/4	4	—	8-1/2 x 8-1/2
5ACC10WD	10 x 10	12-3/4 x 12-3/4	5	5DDW10	10-1/2 x 10-1/2
5ACC11WD	11 x 11	13-3/4 x 13-3/4	5	5DDW12	11-1/2 x 11-1/2
5ACC12WD	12 x 12	14-3/4 x 14-3/4	6	5DDW13	12-1/2 x 12-1/2
5ACC13WD	13 x 13	15-3/4 x 15-3/4	6	5DDW15	13-1/2 x 13-1/2
5ACC14WD	14 x 14	16-3/4 x 16-3/4	7	5DDW16	14-1/2 x 14-1/2
5ACC15WD	15 x 15	17-3/4 x 17-3/4	7	5DDW18	15-1/2 x 15-1/2

Roof Mount Backdraft Dampers

Roof Model No.	Damper Size (In.)	Outside Flange Dimension (In.)	Ship Wt. (Lbs.)	For Use with These Ventilator Model No. (UL 705 Only)	Recommended Roof Opening
5ACC12RD	12 x 12	14 x 14	4	5BDU10, 5DDU10, 5ADE10, 5BDD10, 5DDD10	12-1/2 x 12-1/2
5ACC15RD	15 x 15	17 x 17	6	5BDU12, 5DDD08, 5DDU08, 5BDU13, 5DDU12, 5DDU13, 5ADE12, 5ADE14, 5BDD12, 5BDD13, 5DDD12, 5DDD13	15-1/2 x 15-1/2
5ACC15SD	15 x 15	17 x 17	6	5ADS12, 5ADS14	15-1/2 x 15-1/2
5ACC19RD	19 x 19	21 x 21	7	5BDU15, 5BDU16, 5DDU15, 5DDU16, 5ADE16, 5ABE18, 5BDD15, 5BDD16, 5DDD15, 5DDD16, 1RHE24	19-1/2 x 19-1/2
5ACC19SD	19 x 19	21 x 21	7	5ADS16, 1RHS24	19-1/2 x 19-1/2
5ACC23RD	23 x 23	25 x 25	9	5BDU18, 5BDU20, 5DDU18, 5ADE18, 5BDD18, 5BDD20, 5DDD18	23-1/2 x 23-1/2
5ACC23SD	23 x 23	25 x 25	9	5ADS18, FSU10	23-1/2 x 23-1/2
5ACC27RD	27 x 27	29 x 29	13	5BDU24, 5ADE20, 5ADE24, 5ABE24, 5BDD24, 1RHE30	27-1/2 x 27-1/2
5ACC27SD	27 x 27	29 x 29	13	5ADS20, 5ADS24, 5FSU12, 5FSU15, 1RHS30	27-1/2 x 27-1/2
5ACC30RD	30 x 30	32 x 32	12	1RHE30	30-1/2 x 30-1/2
5ACC30SD	30 x 30	32 x 32	12	1RHS36	30-1/2 x 30-1/2
5ACC35RD	35 x 35	37 x 37	20	5BDU30, 5ABE30, 5BDD30	35-1/2 x 35-1/2
5ACC35SD	35 x 35	37 x 37	20	5FSU18	35-1/2 x 35-1/2
5ACC39RD	39 x 39	41 x 41	26	5BDU36, 5ABE36, 5BDD36	39-1/2 x 39-1/2
5ACC39SD	39 x 39	41 x 41	26	1RHS42, FSU20	39-1/2 x 39-1/2
5ACC48RD	48 x 48	50 x 50	25	1RHE48	48-1/2 x 48-1/2
5ACC49SD	48 x 48	50 x 50	25	1RHS48	48-1/2 x 48-1/2
5ACC50RD	50 x 50	52 x 52	34	5BDD49	50-1/2 x 50-1/2

Ceiling Exhaust Ventilators

Features and Benefits

Quiet, built-in automatic back-draft damper located in duct connector

Sound-absorbing acoustic insulation completely lines housing to further reduce sound levels (kitchen and dedicated inline models contain no insulation)

Quiet, low RPM motor – permanently lubricated for continuous operation

Round duct connectors on many models for easy installations

Impact-resistant, balanced centrifugal blower wheel ensures consistent performance

Heavy gauge galvanized steel housing

Eight-way adjustable mounting brackets permit installation flexibility

Specially designed resilient motor mounts help eliminate vibration

Quick, simple wiring from either inside or outside of housing.

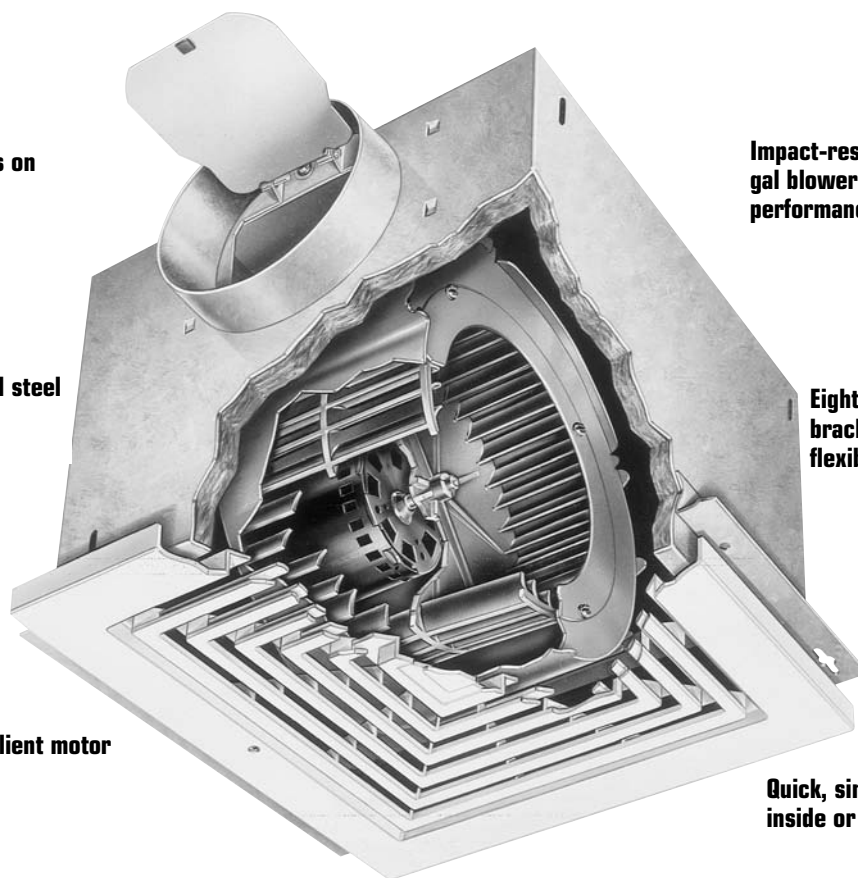

Low profile grille complements any surroundings. Impact-resistant, high strength polymer or white enameled steel (depending on model)

1RHE36

36-1/2 x 36-1/2

Ceiling Exhaust Ventilators

Ceiling/Wall Fans 50 CFM

Simple installation and dependability make this odor- and moisture-removing fan a real value.

Features and Specifications

Grille:

- White polymeric — blends well with any decor
- Torsion spring grille mounting — no tools required
- Metal grille kit available (purchase separately)

Motor:

- Plug-in, permanently lubricated
- Polymeric blower wheel
- Snap-in/out motor assembly for easy cleaning — no screws to drive or drop

Housing:

- Compact, 25 gauge galvanized steel — attaches easily to wall or ceiling joists

- Double-strength mounting flanges with keyhole slots
- Removable wiring cover — make connections away from tight corners
- No electrical knockout to remove
- Polymeric duct fitting with tapered sleeve for easy, positive duct connection
- Quiet polymeric damper prevents cold backdrafts — no metallic clatter
- UL Listed for tub or shower enclosure with GFCI branch wiring

Accessories (available separately)

- For more information, see Ceiling Exhaust Ventilation Accessories
- Model 57V (ivory)/57W (white) 3 amp electronic variable speed control
- Model 59V/59W 60-minute time control
- Model 61V/61W 15-minute time control
- Shipping weight 4.2 pounds

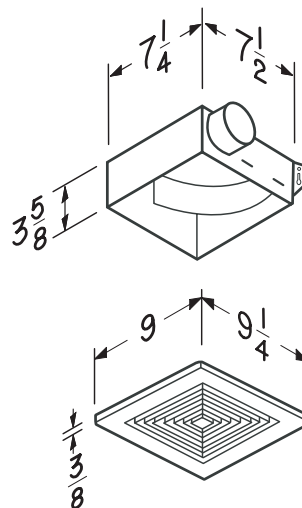

Fantech, Inc. and Systemair Mfg. Inc. certify that the Ceiling/Wall Fans 50 CFM shown herein are licensed to bear the AMCA Seal. The ratings shown are based on tests and procedures performed in accordance with AMCA Publication 211 and AMCA Publication 311 and comply with the requirements of the AMCA Certified Ratings Program.

Model No.	Duct Size (In.)	Nominal RPM	Volts	Watts	Sones@ 0.0" SP	0.0" SP CFM	0.100" SP CFM	0.125" SP CFM	0.250" SP CFM	0.375" SP CFM
6CEV005A	3" Round	1870	120	55	3.9	52	49	47	42	29

The performances shown are with inlet grille, backdraft damper and outlet duct. Speed (RPM) shown is nominal. Performance is based on actual speed of test. The sound ratings shown are loudness values in fan sones at 5' (1.5m) in a hemispherical free field calculated per AMCA Standard 301. Values shown are for Installation Type B: Free Inlet hemispherical sone levels.

Typical Specifications:

Ceiling Exhaust and Inline Ventilators

Ventilator shall have galvanized steel housing with double-strength mounting flanges. It shall be ducted vertically (horizontally) to a roof cap (wall cap). Motor assembly shall be removable and permanently lubricated. Air delivery shall be no less, and sound levels no greater, than listed. All air and sound ratings shall be certified by AMCA. Unit shall be UL Listed for use over bathtubs and showers when connected to a GFCI protected branch circuit. All fans shall bear the AMCA Certified Ratings seal for sound and air performance. Units to be UL and cUL Listed. Each fan shall bear a permanently affixed manufacturer's nameplate containing model number and carry a one-year warranty. Fans shall be Fantech Model Ceiling/Wall Fans 50 CFM as manufactured by Systemair Mfg. Inc., Lenexa, Kansas.

Ceiling Exhaust Ventilators

Ceiling/Wall Fans 80 CFM

Dependable, high-performance bathroom ventilation.

Features and Specifications

Grille:

- Attractive grille conceals interior
- Matte white polymeric – blends well with any decor
- Torsion spring grille mounting – no tools required
- White metal grille kit available (purchase separately)

Blower:

- Plug-in, permanently lubricated motor
- Centrifugal blower wheel

Housing:

- Rugged, 26 gauge galvanized steel construction

- Sturdy keyholed mounting brackets for quick, accurate installation
- Tapered, polymeric duct fitting with built-in backdraft damper for easy, positive duct connection and no metallic clatter
- UL Listed for use over tubs and showers when connected to a GFCI protected branch circuit

Accessories (available separately)

- For more information, see Ceiling Exhaust Ventilation Accessories
- Model 57V (ivory)/57W (white) 3 amp electronic variable speed control
- Model 59V/59W 60-minute time control
- Model 61V/61W 15-minute time control
- Approximate shipping weight 8 pounds

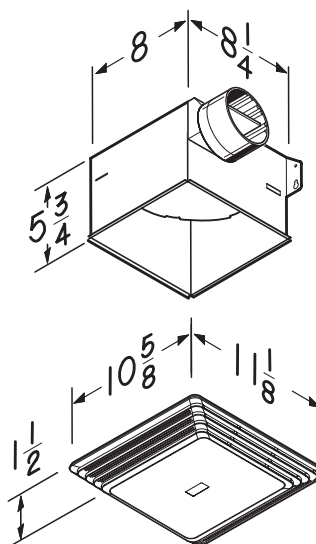

Fantech, Inc. and Systemair Mfg. Inc. certify that the Ceiling/Wall Fans 80 CFM shown herein are licensed to bear the AMCA Seal. The ratings shown are based on tests and procedures performed in accordance with AMCA Publication 211 and AMCA Publication 311 and comply with the requirements of the AMCA Certified Ratings Program.

Model No.	Duct Size (In.)	Nominal RPM	Volts	Watts	0.0" SP	0.100" SP	0.125" SP	0.250" SP	0.375" SP
					CFM Sones	CFM Sones	CFM Sones	CFM Sones	CFM Sones
6CEV008A	4" Round	1550	120	48	89	81	80	68	36
					3.9	3.8	3.8	3.8	3.9

The performance ratings include the effects of inlet grille and backdraft damper. Speed (RPM) shown is nominal. Performance is based on actual speed of test. The sound ratings shown are loudness values in fan sones at 5' (1.5m) in a hemispherical free field calculated per AMCA Standard 301. Values shown are for Installation Type B: Free Inlet hemispherical sone levels. Air Performance certified is for installation type B: Free Inlet, Ducted outlet.

Typical Specification

Ceiling Exhaust and Inline Ventilators

Ventilator shall have galvanized steel housing with dual integral mounting brackets. It shall be ducted vertically (horizontally) to a roof cap (wall cap). Motor assembly shall be removable and have a centrifugal blower wheel and permanently lubricated motor. Air delivery shall be no less, and sound levels no greater, than listed. All air and sound ratings shall be certified by AMCA. Unit shall be UL Listed for use over bathtubs and showers when connected to a GFCI protected branch circuit. All fans shall bear the AMCA Certified Ratings seal for sound and air performance. Units to be UL and cUL Listed. Each fan shall bear a permanently affixed manufacturer's nameplate containing model number and carry a one-year warranty. Fans shall be Fantech Model Ceiling/Wall Fans 50 CFM as manufactured by Systemair Mfg. Inc., Lenexa, Kansas.

Ceiling Exhaust Ventilators

Ceiling and Inline Mount Exhaust Fans 100 to 300 CFM

Incredibly reliable. Unbelievably quiet. Offering the CFM choices you need at the lowest sound levels in the industry.

Features and Specifications

Grille:

- Conceals interior
- Low profile styling blends with any decor
- White polymeric (optional metal finished with white painted enamel available)

Blower:

- Low RPM for quiet operation
- Resilient antivibration mounts
- Dynamically balanced, polymeric, centrifugal blower wheel for quiet, efficient performance
- Permanently lubricated, thermally protected motor
- Plug-in motor rated at 120 VAC
- Designed for continuous operation

Housing:

- Rugged 20 gauge galvanized steel
- 6" round duct connector (6CEV010A, 6CEV015A, 6IEV10A, 6IEV015A)
- 8" round duct connector (6CEV020A, 6CEV025A, 6CEV030A, 6IEV020A, 6IEV025A, 6IEV030A)
- 1/2" acoustic insulation inside (ceiling mount models only)

- May be installed in ceiling or wall (size permitting)
- Eight-position mounting brackets for easy installation and greater adaptability to various mounting requirements
- Automatic backdraft damper located within duct connector
- Factory-shipped in horizontal discharge position – easily converted to vertical discharge
- Ceiling mount models may be installed as an inline ventilator with addition of accessory kit model 961L or 981L (purchase separately)
- Removable panel on dedicated inline mount models allows easy access to the motor without disturbing ductwork

Accessories (available separately)

- For more information, see Ceiling Exhaust Ventilation Accessories
- Model 57V (ivory)/57W (white) 3 amp electronic variable speed control
- Model 59V/59W 60-minute time control
- Model 61V/61W 15-minute time control
- Model 72V/72W (120 VAC) 6 amp electronic variable speed controls – Model 72V/72W (120 VAC)
- Model 961L or 981L Inline adapter plate to convert ceiling mount models
- Model RD1 radiation damper
- Approximate shipping weight 24 pounds

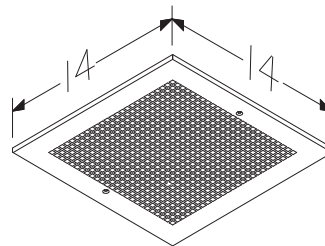
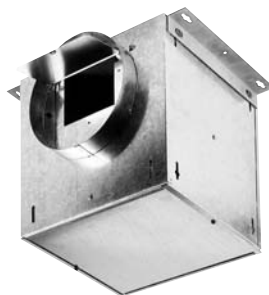

Optional Metal Grille

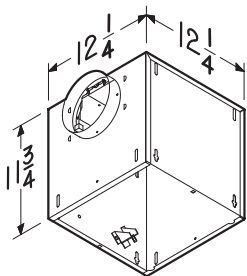

Ceiling Mount

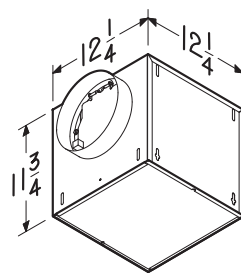

Inline Mount

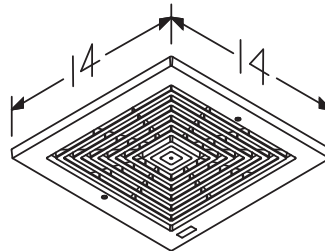

Polymeric Grille



UL Listed for use over bathtubs and showers when connected to a GFCI-protected branch circuit

Fantech, Inc. and Systemair Mfg. Inc. certify that the Ceiling and Inline Mount Exhaust Fans 100 to 300 CFM shown herein are licensed to bear the AMCA Seal. The ratings shown are based on tests and procedures performed in accordance with AMCA Publication 211 and AMCA Publication 311 and comply with the requirements of the AMCA Certified Ratings Program.

Typical Specification

Ceiling Exhaust and Inline Ventilators

Ventilator shall have galvanized steel housing insulated with at least 1/2" of acoustic insulation (Ceiling Mount models only). Housing to have adjustable mounting brackets. Automatic backdraft damper to be located within duct connector. Duct connector, blower assembly and wiring plate shall be adjustable for either horizontal or vertical installation. Blower unit shall be removable from housing and will have a polymeric, dynamically balanced centrifugal-type blower wheel. Motor to be permanently lubricated and mounted with resilient anti-vibration mounts. RPM not to exceed number listed for each model. Air delivery shall be no less, and sound levels no greater, than listed for each model. All fans shall bear the AMCA Certified Ratings seal for sound and air performance. Units to be UL and cUL Listed. Each fan shall bear a permanently affixed manufacturer's nameplate containing model number and carry a one-year warranty. Fans shall be Fantech Model Ceiling and Inline Mount Exhaust Fans 100 to 300 CFM as manufactured by Systemair Mfg. Inc., Lenexa, Kansas.

Ceiling Exhaust Ventilators

Ceiling and Inline Mount Exhaust Fans 100 to 300 CFM

Model No.	Motor RPM @ 0.125"	Max. Amps @ 60 Hz	Watts	Discharge Angle	0.0" SP CFM Sones	0.100" SP CFM Sones	0.125" SP CFM Sones	0.250" SP CFM Sones	0.375" SP CFM Sones	0.500" SP CFM Sones	0.625" SP CFM Sones	0.750" SP CFM Sones	0.875" SP CFM Sones	1.00" SP CFM Sones
6CEV010A	640	1.1	87	Horizontal	136	115	109	93	80	65	44	12	—	—
					0.5	0.8	0.9	1.3	1.8	2.3	3.0	3.2	—	—
6CEV010A With Optional Metal Grille	630	1.1	87	Horizontal	144	121	115	97	83	68	46	12	—	—
					0.5	0.8	0.9	1.2	1.8	2.4	3.0	3.3	—	—
6CEV015A	710	1.3	100	Horizontal	181	161	157	141	132	124	114	94	62	—
					1.3	1.4	1.5	2.2	2.6	3.1	3.6	4.1	4.6	—
6CEV015A With Optional Metal Grille	725	1.3	100	Vertical	179	163	160	149	142	133	122	105	73	23
					1.4	1.6	1.6	2.0	2.5	3.0	3.3	3.6	3.9	4.2
6CEV020A	740	1.8	127	Horizontal	231	214	210	196	186	177	165	144	113	51
					1.6	1.8	1.7	2.3	2.9	3.5	4.1	4.9	5.3	5.3
6CEV020A With Optional Metal Grille	730	1.8	127	Vertical	224	210	207	197	187	179	167	144	99	41
					1.5	1.8	2.0	2.3	2.7	3.4	4.0	4.5	5.1	5.2
6CEV025A	830	2.2	166	Horizontal	272	261	259	250	242	233	218	201	165	99
					2.1	2.3	2.2	2.9	3.3	3.9	4.4	4.8	5.5	5.8
6CEV025A With Optional Metal Grille	860	2.3	166	Vertical	269	261	259	253	248	239	224	203	171	101
					2.3	2.6	2.7	3.0	3.3	3.7	4.2	4.7	5.4	5.6
6CEV030A	935	2.7	212	Horizontal	312	309	308	303	296	287	273	254	219	125
					2.8	2.9	2.9	3.3	3.5	3.9	4.3	4.7	5.1	5.6
6CEV030A With Optional Metal Grille	950	2.7	212	Vertical	319	314	313	306	299	288	274	251	219	120
					2.6	2.9	3.0	3.4	3.6	3.9	4.4	4.7	5.0	5.5
6CEV030A With Optional Metal Grille	915	2.7	212	Horizontal	323	317	316	312	305	298	283	266	235	153
					3.0	2.8	3.0	3.2	3.5	3.9	4.3	4.8	5.2	5.7
6CEV030A With Optional Metal Grille	915	2.7	212	Vertical	322	315	314	308	302	292	278	259	227	119
					2.4	2.7	2.8	3.3	3.5	3.9	4.3	4.7	5.1	5.5

Performance ratings include the effects of inlet grille and backdraft damper. Speed (RPM) shown is nominal. Performance is based on actual speed of test. The sound ratings shown are loudness values in fan sones at 5' (1.5m) in a hemispherical free field calculated per AMCA St. 301. Values shown are for installation type B: free inlet hemispherical sone levels. Performance certified is for installation type B: free inlet, ducted outlet.

Model No.	Motor RPM @ 0.125"	Max. Amps @ 60 Hz	Watts	Discharge Angle	0.0" SP CFM Sones	0.100" SP CFM Sones	0.125" SP CFM Sones	0.250" SP CFM Sones	0.375" SP CFM Sones	0.500" SP CFM Sones	0.625" SP CFM Sones	0.750" SP CFM Sones	0.875" SP CFM Sones	1.00" SP CFM Sones
6IEV010A	760	1.1	87	Straight Thru	121	108	106	97	93	86	70	44	17	—
					0.5	0.7	0.7	1.1	1.4	1.8	2.1	2.4	2.6	—
6IEV015A	920	1.3	100	Straight Thru	109	98	96	88	82	78	67	48	16	—
					0.5	0.8	0.8	1.2	1.6	2.0	2.3	2.5	2.8	—
6IEV020A	865	1.8	127	Straight Thru	153	148	147	140	134	125	111	91	54	18
					0.9	1.0	1.1	1.4	1.6	1.9	2.1	2.2	2.4	2.6
6IEV025A	1005	2.1	166	Straight Thru	144	138	137	131	123	114	102	83	54	17
					1.2	1.4	1.4	1.6	1.9	2.1	2.4	2.5	2.7	2.9
6IEV030A	1090	2.6	212	Straight Thru	205	196	195	190	185	175	158	135	96	47
					1.7	1.9	1.9	2.1	2.3	2.4	3.0	3.3	3.4	3.4
6IEV030A	1285	2.6	212	Right Angle	183	177	176	170	163	152	137	121	96	51
					1.6	1.6	1.6	1.9	2.3	2.7	2.9	3.1	3.4	3.6
6IEV030A	1090	2.6	212	Horizontal	248	245	245	241	235	224	208	183	141	84
					2.0	2.3	2.3	2.6	2.8	3.2	3.4	3.6	3.9	3.8
6IEV030A	1285	2.6	212	Right Angle	229	224	222	214	204	193	177	157	132	95
					2.4	2.5	2.6	2.8	3.0	3.2	3.4	3.7	3.8	3.8
6IEV030A	1090	2.6	212	Horizontal	300	294	293	285	274	259	243	214	168	113
					2.9	3.0	3.1	3.3	3.4	3.5	3.6	3.7	4.0	3.9
6IEV030A	1285	2.6	212	Right Angle	270	261	259	248	234	220	200	174	146	104
					3.7	3.7	3.7	3.7	3.9	3.9	4.0	4.2	4.4	4.0

Performance ratings include the effects of backdraft damper. Speed (RPM) shown is nominal. Performance is based on actual speed of test. The sound ratings shown are loudness values in fan sones at 5' (1.5m) in a hemispherical free field calculated per AMCA Standard 301. Values shown are for Installation Type D: . Ratings do not include the effect of duct end correction. Performance ratings include the effects of 18 feet of round inlet duct and, if needed, a rectangular to round duct transition. Performance certified is for installation type D: Ducted Inlet, Ducted Outlet.

Ceiling Exhaust Ventilators

Ceiling and Inline Mount Exhaust Fans 400 to 700 CFM

Incredibly reliable. Unbelievably quiet. Offering the CFM choices you need at the lowest sound levels in the industry.

Features and Specifications

Grille:

- Conceals interior
- Low profile styling blends with any decor
- Metal finished with white painted enamel

Blower:

- Low RPM for quiet operation
- Resilient antivibration mounts
- Dynamically balanced, polymeric, centrifugal blower wheel for quiet, efficient performance
- Permanently lubricated, thermally protected motor
- Plug-in motor rated at 120 VAC
- Designed for continuous operation

Housing:

- Rugged 20 gauge galvanized steel
- 4-1/2" x 18-1/2" duct connector
- 1/2" acoustic insulation inside (ceiling mount models only)
- May be installed in ceiling or wall (size permitting)

- Eight-position mounting brackets for easy installation and greater adaptability to various mounting requirements
- Automatic backdraft damper located within duct connector
- Factory-shipped in horizontal discharge position – easily converted to vertical discharge
- Ceiling mount models may be installed as an inline ventilator with addition of accessory kit model 982L (purchase separately)
- Removable panel on dedicated inline mount models allows easy access to the motor without disturbing ductwork

Accessories (available separately)

- For more information, see Ceiling Exhaust Ventilation Accessories
- Model 57V (ivory)/57W (white) 3 amp electronic variable speed control
- Model 59V/59W 60-minute time control
- Model 61V/61W 15-minute time control
- Model 72V/72W (120 VAC) 6 amp electronic variable speed controls
- Model 423 Transition (4-1/2" x 18-1/2" to 10" round)
- Model RD2 radiation damper
- Approximate shipping weight 34 pounds

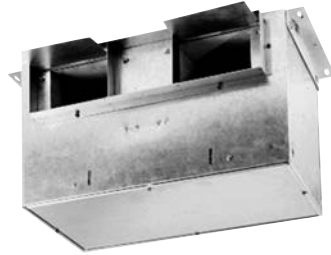
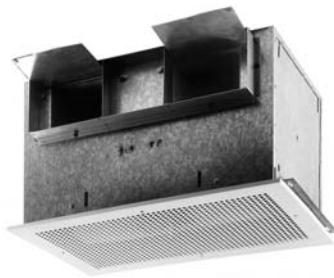

Fantech, Inc. and Systemair Mfg. Inc. certify that the Ceiling and Inline Mount Exhaust Fans 400 to 700 CFM shown herein are licensed to bear the AMCA Seal. The ratings shown are based on tests and procedures performed in accordance with AMCA Publication 211 and AMCA Publication 311 and comply with the requirements of the AMCA Certified Ratings Program.

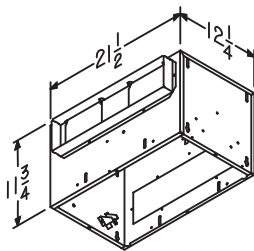

Ceiling Mount

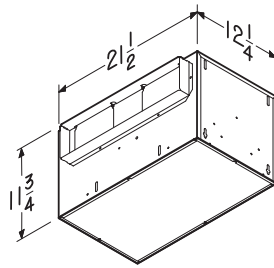

Inline Mount

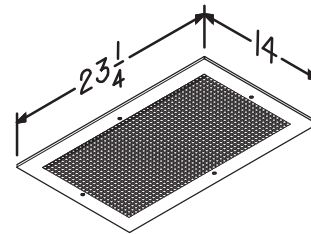

Metal Grille

Typical Specification

Ceiling Exhaust and Inline Ventilators

Ventilator shall have galvanized steel housing insulated with at least 1/2" of acoustic insulation (Ceiling Mount models only). Housing to have adjustable mounting brackets. Automatic backdraft damper to be located within duct connector. Duct connector, blower assembly and wiring plate shall be adjustable for either horizontal or vertical installation. Blower unit shall be removable from housing and will have a polymeric, dynamically balanced centrifugal-type blower wheel. Motor to be permanently lubricated and mounted with resilient anti-vibration mounts. RPM not to exceed number listed for each model. Air delivery shall be no less, and sound levels no greater, than listed for each model. All fans shall bear the AMCA Certified Ratings seal for sound and air performance. Units to be UL and cUL Listed. Each fan shall bear a permanently affixed manufacturer's nameplate containing model number and carry a one-year warranty. Fans shall be Fantech Model Ceiling and Inline Mount Exhaust Fans 400 to 700 CFM as manufactured by Systemair Mfg. Inc., Lenexa, Kansas.

Ceiling Exhaust Ventilators

Ceiling and Inline Mount Exhaust Fans 400 to 700 CFM

Model No.	Motor RPM @ 0.125"	Max. Amps @ 60 Hz	Watts	Discharge Angle	0.0"	0.100"	0.125"	0.250"	0.375"	0.500"	0.625"	0.750"	0.875"	1.00"
					SP CFM Sones	SP CFM Sones	SP CFM Sones	SP CFM Sones	SP CFM Sones	SP CFM Sones	SP CFM Sones	SP CFM Sones	SP CFM Sones	
6CEV040A	735	1.4	146	Vertical	480	442	434	388	344	299	229	182	114	33
					2.0	2.4	2.3	2.8	3.3	3.8	4.5	4.8	5.4	5.6
6CEV040A	755	1.4	146	Horizontal	467	428	416	378	335	291	237	170	85	8
					2.3	2.6	2.6	3.0	3.5	4.0	5.1	5.5	5.7	5.9
6CEV050A	810	2.2	232	Vertical	538	520	514	491	463	434	389	339	282	186
					3.0	3.1	3.3	3.6	4.0	4.4	5.0	5.7	6.2	6.7
6CEV050A	865	2.2	232	Horizontal	539	517	512	481	451	418	367	319	247	137
					2.9	3.1	3.2	3.4	3.8	4.2	4.8	5.9	6.3	6.4
6CEV070A	960	2.9	313	Vertical	722	704	701	667	640	607	571	534	453	333
					4.5	4.6	4.7	4.8	5.0	5.2	5.6	6.2	7.1	7.2
6CEV070A	985	2.9	313	Horizontal	708	691	687	658	628	597	560	515	444	312
					5.2	5.0	5.0	5.7	5.8	6.1	6.4	7.4	7.1	7.6

Performance ratings include the effects of inlet grille and backdraft damper. Speed (RPM) shown is nominal. Performance is based on actual speed of test. The sound ratings shown are loudness values in fan sones at 5' (1.5m) in a hemispherical free field calculated per AMCA Standard 301. Values shown are for Installation Type B: Free Inlet hemispherical sone levels. Performance certified is for installation type B: Free Inlet, Ducted Outlet.

Model No.	Motor RPM @ 0.125"	Max. Amps @ 60 Hz	Watts	Discharge Angle	0.0"	0.100"	0.125"	0.250"	0.375"	0.500"	0.625"	0.750"	0.875"	1.00"
					SP CFM Sones	SP CFM Sones	SP CFM Sones	SP CFM Sones	SP CFM Sones	SP CFM Sones	SP CFM Sones	SP CFM Sones	SP CFM Sones	SP CFM Sones
6IEV040A	775	1.4	146	Straight Thru	450	415	406	360	313	271	223	167	90	6
					1.4	1.6	1.6	1.9	2.2	2.6	2.9	3.4	3.6	3.9
6IEV040A	875	1.4	146	Right Angle	442	415	408	372	336	296	239	193	111	28
					1.6	1.7	1.7	2.0	2.4	2.6	3.1	3.4	3.9	4.1
6IEV050A	890	2.2	232	Straight Thru	546	526	519	496	472	447	407	364	306	232
					2.4	2.4	3.4	3.7	3.9	3.8	3.9	4.0	4.3	4.3
6IEV050A	990	2.2	232	Right Angle	528	516	513	494	470	446	415	389	334	247
					2.9	3.8	3.4	3.7	3.5	3.6	3.9	4.0	4.2	4.4
6IEV070A	1090	2.9	313	Straight Thru	704	686	681	656	631	604	575	533	480	412
					3.6	3.8	3.7	3.9	4.0	4.2	4.3	4.4	4.7	5.0
6IEV070A	1205	2.9	313	Right Angle	680	667	663	644	621	594	557	513	440	342
					5.0	5.0	5.0	5.3	5.2	5.1	5.3	5.5	5.4	5.5

Performance ratings include the effects of backdraft damper. Speed (RPM) shown is nominal. Performance is based on actual speed of test. The sound ratings shown are loudness values in fan sones at 5' (1.5m) in a hemispherical free field calculated per AMCA Standard 301. Values shown are for Installation Type D: ducted inlet hemispherical sones levels. Ratings do not include the effect of duct end correction. Performance ratings include the effects of 18 feet of round inlet duct and, if needed, a rectangular to round duct transition. Performance certified is for installation type D: Ducted Inlet, Ducted Outlet.

Ceiling Exhaust Ventilators

Ceiling and Inline Mount Exhaust Fans 900 to 1500 CFM

Incredibly reliable. Unbelievably quiet. Offering the CFM choices you need at the lowest sound levels in the industry.

Features and Specifications

Grille:

- Conceals interior
- Low profile styling blends with any decor
- Metal finished with white painted enamel

Blower:

- Low RPM for quiet operation
- Resilient antivibration mounts
- Dynamically balanced, polymeric, centrifugal blower wheel for quiet, efficient performance
- Permanently lubricated, thermally protected motor
- Plug-in motor rated at 120 VAC
- Designed for continuous operation

Housing:

- 8" x 12" duct connector
- Rugged 20 gauge galvanized steel
- 1/2" acoustic insulation inside (ceiling mount models only)

- May be installed in ceiling or wall (size permitting)
- Eight-position mounting brackets for easy installation and greater adaptability to various mounting requirements
- Automatic backdraft damper located within duct connector
- Factory-shipped in horizontal discharge position – easily converted to vertical discharge
- Ceiling mount models may be installed as an inline ventilator with addition of accessory kit model 983L (purchase separately)
- Removable panel on dedicated inline mount models allows easy access to the motor without disturbing ductwork

Accessories (available separately)

- For more information, see Ceiling Exhaust Ventilation Accessories
- Model 57V (ivory)/57W (white) 3 amp electronic variable speed control
- Model 59V/59W 60-minute time control
- Model 61V/61W 15-minute time control
- Model 72V/72W (120 VAC) 6 amp electronic variable speed controls
- Model T81212 Transition (8" x 12" to 12" round)
- Model RD3 radiation damper
- Approximate shipping weight 65 pounds

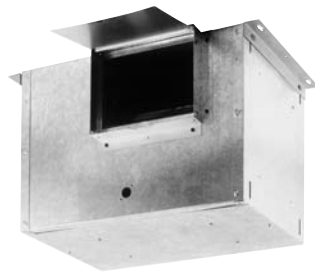
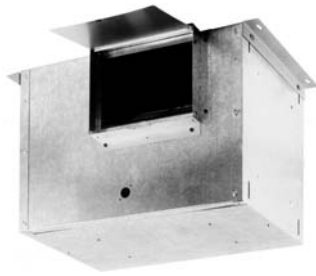

Fantech, Inc. and Systemair Mfg. Inc. certify that the Ceiling and Inline Mount Exhaust Fans 900 to 1500 CFM shown herein are licensed to bear the AMCA Seal. The ratings shown are based on tests and procedures performed in accordance with AMCA Publication 211 and AMCA Publication 311 and comply with the requirements of the AMCA Certified Ratings Program.

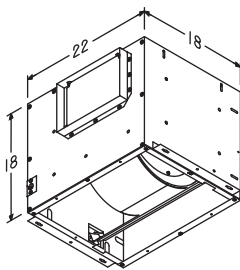

Ceiling Mount

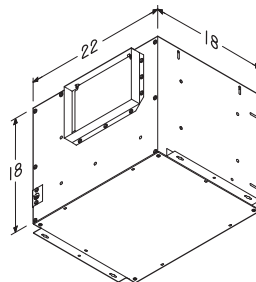

Inline Mount

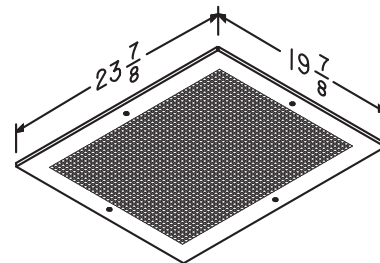

Metal Grille

Typical Specification

Ceiling Exhaust and Inline Ventilators

Ventilator shall have galvanized steel housing insulated with at least 1/2" of acoustic insulation (Ceiling Mount models only). Housing to have adjustable mounting brackets. Automatic backdraft damper to be located within duct connector. Duct connector, blower assembly and wiring plate shall be adjustable for either horizontal or vertical installation. Blower unit shall be removable from housing and will have a polymeric, dynamically balanced centrifugal-type blower wheel. Motor to be permanently lubricated and mounted with resilient anti-vibration mounts. RPM not to exceed number listed for each model. Air delivery shall be no less, and sound levels no greater, than listed for each model. All fans shall bear the AMCA Certified Ratings seal for sound and air performance. Units to be UL and cUL Listed. Each fan shall bear a permanently affixed manufacturer's nameplate containing model number and carry a one-year warranty. Fans shall be Fantech Model Ceiling and Inline Mount Exhaust Fans 900 to 1500 CFM as manufactured by Systemair Mfg. Inc., Lenexa, Kansas.

Ceiling Exhaust Ventilators

Ceiling and Inline Mount Exhaust Fans 900 to 1500 CFM

Model No.	Motor RPM @ 0.125"	Max. Amps @ 60 Hz	Watts	Discharge Angle	0.0"	0.100"	0.125"	0.250"	0.375"	0.500"	0.625"	0.750"	0.875"	1.00"
					SP CFM Sones	SP CFM Sones	SP CFM Sones	SP CFM Sones	SP CFM Sones	SP CFM Sones	SP CFM Sones	SP CFM Sones	SP CFM Sones	SP CFM Sones
6CEV090A	650	3.0	306	Straight Thru	918 3.8	905 4.0	901 4.1	877 4.0	842 4.2	793 4.3	725 4.4	636 4.9	536 4.5	390 5.3
	675	3.0	306	Right Angle	909 3.8	892 3.4	885 3.4	850 3.5	807 3.6	756 3.7	695 3.9	568 4.2	440 4.3	282 4.4
6CEV150A	955	5.0	468	Straight Thru	1578 8.6	1526 8.4	1513 8.4	1438 8.1	1371 7.5	1285 7.0	1198 6.7	1103 6.2	1000 5.8	816 5.8
	955	5.0	468	Right Angle	1590 8.5	1519 8.4	1502 8.4	1423 8.1	1340 7.9	1259 7.5	1176 7.2	1069 7.1	954 6.9	689 6.5

Performance ratings include the effects of inlet grille and backdraft damper. Speed (RPM) shown is nominal. Performance is based on actual speed of test. The sound ratings shown are loudness values in fan sones at 5' (1.5m) in a hemispherical free field calculated per AMCA Standard 301. Values shown are for Installation Type B: Free Inlet hemispherical sone levels. Performance certified is for installation type B: Free Inlet, Ducted Outlet.

Model No.	Motor RPM @ 0.125"	Max. Amps @ 60 Hz	Watts	Discharge Angle	0.0"	0.100"	0.125"	0.250"	0.375"	0.500"	0.625"	0.750"	0.875"	1.00"
					SP CFM Sones	SP CFM Sones	SP CFM Sones	SP CFM Sones	SP CFM Sones	SP CFM Sones	SP CFM Sones	SP CFM Sones	SP CFM Sones	SP CFM Sones
6IEV090A	810	3.0	306	Straight Thru	930 3.7	902 3.8	894 3.8	853 3.8	807 3.7	754 3.8	685 3.9	587 4.0	442 4.0	300 4.1
	755	3.0	306	Right Angle	795 4.3	778 4.5	772 4.4	743 4.6	709 4.4	668 4.2	613 4.1	527 4.3	432 4.2	291 4.3
6IEV150A	1055	5.0	468	Straight Thru	1275 6.8	1228 6.8	1214 6.7	1152 6.5	1092 6.3	1029 6.0	958 6.0	871 6.0	764 6.0	631 6.1
	1020	5.0	468	Right Angle	1160 7.9	1117 7.8	1106 7.9	1051 7.4	998 7.1	928 6.8	856 6.3	769 5.9	657 5.4	499 5.4

Performance ratings include the effects of backdraft damper. Speed (RPM) shown is nominal. Performance is based on actual speed of test. The sound ratings shown are loudness values in fan sones at 5' (1.5m) in a hemispherical free field calculated per AMCA Standard 301. Values shown are for Installation Type D: ducted inlet hemispherical sones levels. Ratings do not include the effect of duct end correction. Performance ratings include the effects of 18 feet of round inlet duct and, if needed, a rectangular to round duct transition. Performance certified is for installation type D: Ducted Inlet, Ducted Outlet.

Ceiling Exhaust Ventilators

Inline Mount Exhaust Fans 2000 to 3500 CFM

Incredibly reliable. Unbelievably quiet. Offering the CFM choices you need at the lowest sound levels in the industry.

Features and Specifications

Blower:

- Low RPM for quiet operation
- Resilient antivibration mounts
- Dynamically balanced, polymeric, centrifugal blower wheel for quiet, efficient performance
- Permanently lubricated, thermally protected motor
- Plug-in motor rated at 120 VAC (Model 6IEV350C – 240 VAC)
- Designed for continuous operation

Housing:

- Rugged 20 gauge galvanized steel
- May be installed in ceiling or wall (size permitting, grille kit optional)
- Eight-position mounting brackets for easy installation and greater adaptability to various mounting requirements
- Factory-shipped in horizontal discharge position – easily converted to vertical discharge
- Removable panel on dedicated inline mount models allows easy access to the motor without disturbing ductwork

Accessories (available separately)

- For more information, see Ceiling Exhaust Ventilation Accessories
- Model 59V (ivory)/59W (white) 60-minute time control
- Model 61V/61W 15-minute time control
- Model 72V/72W (120 VAC) 6 amp electronic variable speed controls
- Model 75V (240 VAC) 6 amp electronic variable speed controls

Model 6IEV200A:

- Model G102 Grille Kit for ceiling applications
- Model D100 Damper Kit with twin backdraft flaps
- Model V104 Vibration Damper Hangers, 4 per set
- Approximate shipping weight 89 pounds

Model 6IEV350C

- Model G103 Grille Kit for ceiling applications
- Model D101 Damper Kit with twin backdraft flaps
- Model V104 Vibration Damper Hangers, 4 per set
- Approximate shipping weight 144 pounds



Shown with optional metal grille

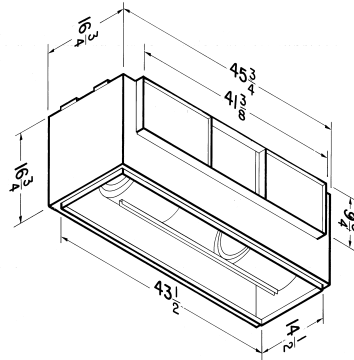

Fantech, Inc. and Systemair Mfg. Inc. certify that the Inline Mount Exhaust Fans 2000 to 3500 CFM shown herein are licensed to bear the AMCA Seal. The ratings shown are based on tests and procedures performed in accordance with AMCA Publication 211 and AMCA Publication 311 and comply with the requirements of the AMCA Certified Ratings Program.

Typical Specification

Ceiling Exhaust and Inline Ventilators: Ventilator shall have galvanized steel housing. Housing to have adjustable mounting brackets. Automatic backdraft damper to be located within duct connector. Duct connector, blower assembly and wiring plate shall be adjustable for either horizontal or vertical installation. Blower unit shall be removable from housing and will have a polymeric, dynamically balanced centrifugal-type blower wheel. Motor to be permanently lubricated and mounted with resilient anti-vibration mounts. RPM not to exceed number listed for each model. Air delivery shall be no less, and sound levels no greater, than listed for each model. All fans shall bear the AMCA Certified Ratings seal for sound and air performance. Units to be UL and cUL Listed. Each fan shall bear a permanently affixed manufacturer's nameplate containing model number and carry a one-year warranty. Fans shall be Fantech Model Inline Mount Exhaust Fans 2000 to 3500 CFM as manufactured by Systemair Mfg. Inc., Lenexa, Kansas.

Model No.	Nominal Voltage	Motor RPM @ 0.125"	Max. Amps @ 60 Hz	Watts	Discharge Angle	SP	SP	SP	SP	SP	SP	SP	SP	SP	SP
						0.0" CFM Sones	0.100" CFM Sones	0.125" CFM Sones	0.250" CFM Sones	0.375" CFM Sones	0.500" CFM Sones	0.625" CFM Sones	0.750" CFM Sones	0.875" CFM Sones	1.00" CFM Sones
6IEV200A	120 VAC	965	5.8	590	Straight Thru	1891	1803	1791	1657	1508	1347	1165	808	284	—
						10.3	9.8	9.4	9.0	8.6	9.1	8.9	7.0	6.7	—
		1020	5.8	635	Right Angle	2070	1931	1898	1769	1609	1424	1314	795	288	—
						11.1	10.3	10.1	9.7	9.4	9.2	8.5	7.0	6.7	—
6IEV350C	240 VAC	1105	5.4	1204	Straight Thru	3605	3498	3452	3278	3073	2893	2679	2429	2093	1693
						15.3	14.8	14.5	14.1	13.1	12.8	12.1	11.8	11.9	10.8
		1110	5.4	1205	Right Angle	3868	3714	3696	3537	3356	3168	2951	2671	2384	2005
						14.6	14.2	14.2	13.3	12.8	12.5	11.6	11.4	11.4	13.4

Performance ratings do not include the effects of appurtenances (accessories). Speed (RPM) shown is nominal. Performance is based on actual speed of test. The sound ratings shown are loudness values in fan sones at 5' (1.5m) in a hemispherical free field calculated per AMCA Standard 301. Values shown are for Installation Type D: ducted inlet hemispherical sones levels. Ratings do not include the effect of duct end correction. Performance certified is for installation type D: Ducted Inlet, Ducted Outlet.

Ceiling Exhaust Ventilators

Performance Charts

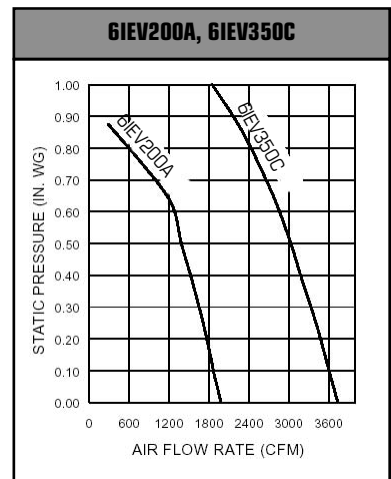
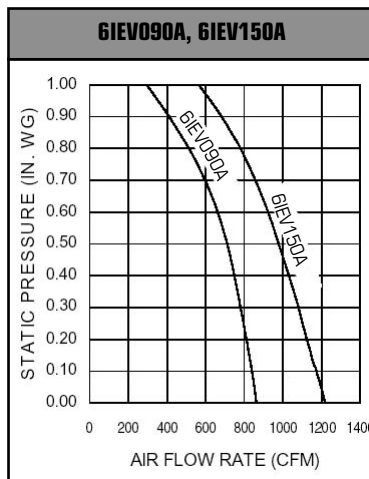
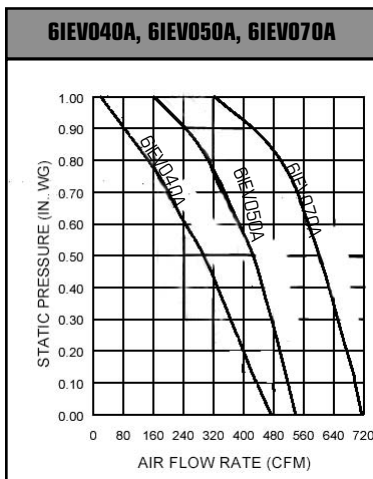
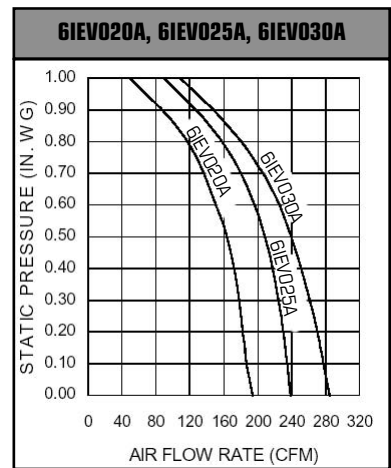
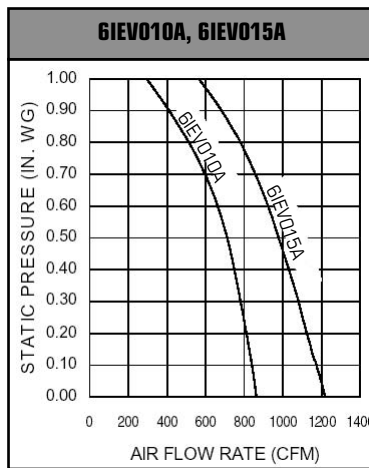
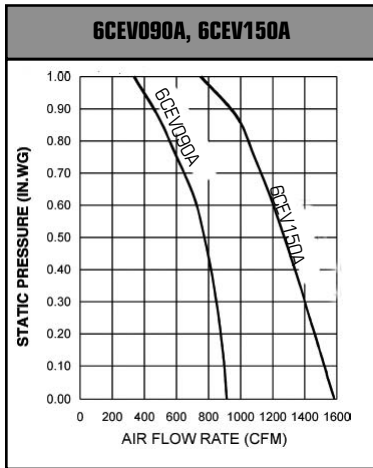
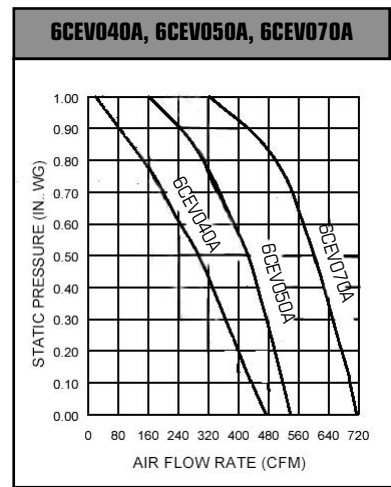
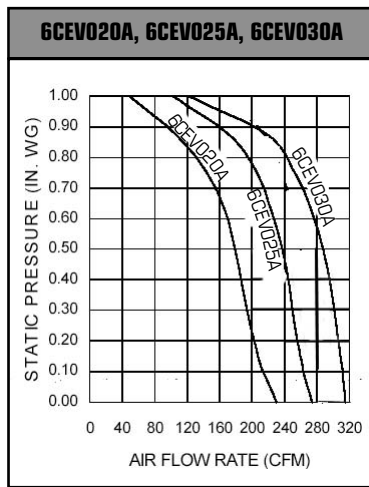
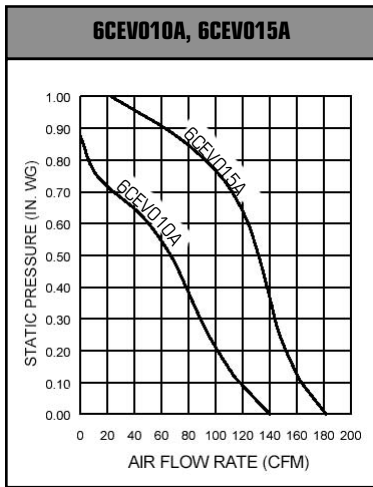

Ceiling Exhaust Ventilators

Accessories

WALL CONTROLS*

Model 57W, 57V Speed Control

- 120V, 3 amps
- Fits single-gang box
- Positive on/off action - dial for variable selection of air speeds and sound levels

Model 59W, 59V Time Control

- 120V, 20 amps; 240V 10 amps
- Operates continuously or for any set period up to 60 minutes



Model 61W, 61V Time Control

- Operates for any set period up to 15 minutes (no "continuous on" position)

Other features same as 59 W/59V

Model 64V Fan/Light Control With Off-Delay

- Fan and light operate together when control is turned on. Fan continues to operate for a user adjustable time period 5 to 60 minutes after light is turned off



- Center position bypasses timer and turns fan and light off immediately

- Fits single-gang box
- 120V, 4 amps (fan); 4 amps (light)
- Requires hot and neutral wires in the switch box

Model 72W, 72V, 75V Speed Control

- 120V, 6 amps (models 72W, 72V)
- 240V, 6 amps (model 75V)
- Other features same as 57W/57V



Model 277V Speed Control

- 277V, 6 amps
- Other features same as 72W/72V

ROOF CAPS

Model 437

- High-capacity design — up to 1200 CFM
- Built-in bird screen



- Steel housing, black electrically bonded epoxy finish

Model 611

- For flat roof installation
- Aluminum natural finish
- For up to 8" round duct



Model 611CM

- For curb mount installation
- Other features same as model 611



Model 612

- For flat roof installation
- Aluminum natural finish
- For up to 12" round duct

Model 612CM

- For curb mount installation
- Other features same as model 612

Model 634P

- For 1-3/4" x 10" or up to 8" round duct
- Built-in backdraft damper and bird screen
- Steel baked black enamel finish

Model 634M

- Same as model 634, except for 6" round duct



Model 644

- Same as model 634, except aluminum natural finish

Model 636P

- Same as model 634, except for 3" or 4" round duct

WALL CAPS

Model 441

- For 10" round duct
- Steel with aluminum louvers



Model 613

- For 12" round duct
- Built-in backdraft damper and bird screen
- Aluminum natural finish

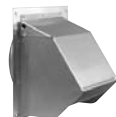

Model 641

- Same as model 613, except for 6" round duct

Model 642

- Same as model 613, except for 3" or 4" round duct

Model 643P

- Same as model 613, except for 8" round duct

INLINE ADAPTERS

Model 961L

- Galvanized steel
- 6" round duct intake



Model 981L

- Galvanized steel
- 8" round duct intake

Model 982L

- Galvanized steel
- 4-1/2" x 18-1/2" duct intake



Model 983L

- Galvanized steel
- 8" x 12" duct intake



RADIATION DAMPERS

Models RD1, RD2 and RD3

- UL rated four-hour ceiling radiation dampers
- Galvanized steel
- High temperature, non-asbestos, reinforced fiber thermal fabric
- 165°F fusible link
- Stainless steel negator-type closure spring
- RD1 (12-1/4" x 12-1/4")
- RD2 (21-1/2" x 12-1/4")
- RD3 (22" x 18")

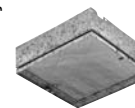

METAL GRILLE KIT

Model MG1, G102, G103

- White enamel painted steel
- Mounting screws included

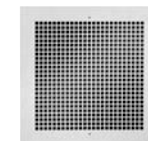

BRICK VENTS

Model BV8, BV12 and BV16

- Designed for installation in masonry walls
- Anodized aluminum construction
- Built-in aluminum mesh insect screen

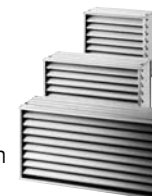

- BV8 (7-3/4" x 8-1/8" x 4")
- BV12 (7-3/4" x 12" x 4")
- BV16 (7-3/4" x 15-5/8" x 4")

DUCT TRANSITIONS

Models 423 and T81212

- Galvanized steel
- Allows for quick transition to easy-to-obtain-and-install round ducting
- 423 (4-1/2" x 18-1/2" to 10" round)
- T81212 (8" x 12" to 12" round)

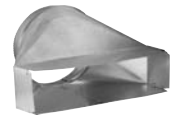

DAMPER KIT

Models D100 and D101

- Not illustrated
- Twin damper flaps and mounting hardware
- Foam cushion and magnetic catch ensures quiet, effective backdraft prevention

VIBRATION DAMPENING HANGERS

Model V104

- Not illustrated
- Heavy gauge steel construction with neoprene vibration dampening cushion
- Maximum load 75 lbs. each
- For 3/8" diameter threaded rod (available separately)
- Set of four required for each ventilator

*W = White V = Ivory

Ceiling Exhaust Ventilators

Accessories Application Chart

Model No.	Ceiling Mount Series							Insert Series						
	6CEV005A 6CEV008A	6CEV010A 6CEV015A	6CEV020A 6CEV025A 6CEV030A	6CEV040A 6CEV050A	6CEV070A	6CEV090A	6CEV150A	6IEV010A 6IEV015A	6IEV020A 6IEV025A 6IEV030A	6IEV040A 6IEV050A 6IEV070A	6IEV090A	6IEV150A	6IEV200A	6IEV350C
Wall-Mounted Controls														
59VW (120/240)	X	X												
61VW (120/240)	X	X	X	X	X	X	X	X	X	X	X	X	X	
64V (120)	X	X	X	X	X	X	X	X	X	X	X	X	X	
72VW (120)	X	X	X	X	X	X	X	X	X	X	X	X	X	
75VW (240)	X	X	X	X	X	X	X	X	X	X	X	X	X	X
Roof Caps														
437				X	X					X				
611, 611CM		X	X					X	X					
612, 612CM		X	X	X	X	X	X	X	X	X	X	X		
634M		X						X						
634P, 644		X	X					X	X					
636P	X													
Wall Caps														
441				X	X					X				
613						X	X				X	X		
641		X						X						
642	X													
643			X						X					
Inline Adapters														
961L		X												
981L			X											
982L				X	X									
983L						X	X							
Radiation Dampers														
RD1		X	X											
RD2				X	X									
RD3						X	X							
Metal Grille Kit														
97011308	X												X	
G102														X
G103														
MG1		X	X											
Grease Filters														
LAF1	X	X	X											
LAF2				X	X									
Brick Vents														
BV8	X	X	X											
BV12	X	X	X	X										
BV16	X	X	X	X	X	X								
Duct Transitions														
423														
TB1212				X	X					X		X	X	
Damper Kit														
D100													X	
D101														X
Vibrating Damper Hangers														
V104 (Set of 4 required)													X	X

Direct Drive Propeller Fans

7" to 36" Shutter Mounted Exhaust Fans

Shutter mounted exhaust fans are widely used for ventilating stores, offices, factories, shops and farm buildings.

Features and Specifications

- Mounting holes in shutter frame allow for easier installation
- Guards comply with OSHA regulations
- 7" to 24" diameter fans have aluminum propellers; 30" and 36" fans have galvanized steel propellers

- Two-speed unit requires No. 2ACCO2SW two-speed switch (sold separately)
- Easy to install, efficient exhaust fans have automatic shutters
- Heavy duty guards have gray polyester coating to resist corrosion
- Totally enclosed, sleeve or ball bearing, 115V, 60 Hz motors
- Shipped completely assembled

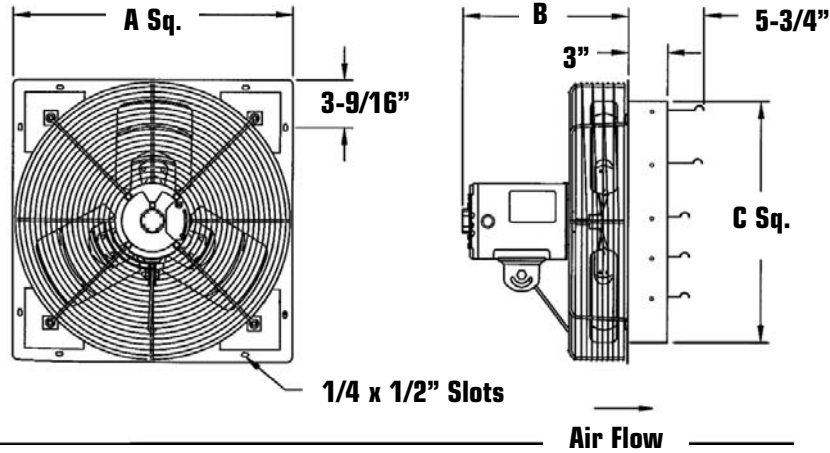
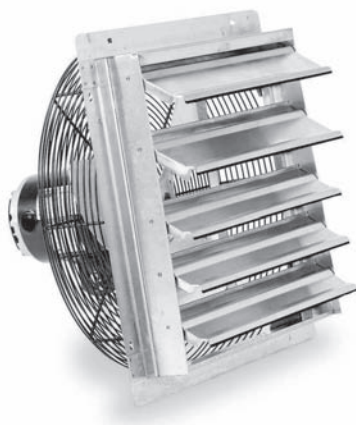

Fantech, Inc. and Systemair Mfg. Inc. certify that the 7" to 36" Shutter Mounted Exhaust Fans shown herein are licensed to bear the AMCA Seal. The ratings shown are based on tests and procedures performed in accordance with AMCA Publication 211 and AMCA Publication 311 and comply with the requirements of the AMCA Certified Ratings Program.

Model No.	Prop. Dia. (In.)	A Square Panel Size (In.)	B	C Square Opening Required (In.)	HP	Nominal RPM	Bearing Type	Full Load Amps	Sones @ 5 Ft. 0.0" SP	CFM Air Delivery			Ship Wt. (lbs.)	Speed Controller Model No.
										0.0" SP	0.125" SP	0.250" SP		
SPEED CONTROLLABLE														
2SHE0721	7	11 1/8	4 15/16	8 1/2	1/30	1725	Sleeve	1.4	4.8	140	—	—	9	5ACCO3SC
2SHE1021	10	13 1/8	5 3/7	10 1/2	1/30	1585	Sleeve	1.4	6.6	585	285	—	10	5ACCO3SC
2SHE1221	12	15 1/8	6	13	1/30	1570	Sleeve	1.4	7.6	800	470	—	12	5ACCO3SC
2SHE1621	16	19 1/8	6 13/16	17	1/20	1550	Sleeve	1.5	8.0	1095	720	—	20	5ACCO3SC
2SHE1871	18	21 1/8	8 1/2	18 1/2	1/15	1075	Sleeve	1.2	8.4	1860	850	—	23	5ACCO3SC
2SHE20B1W	20	23 1/8	10 3/4	21	1/4	1150	Sleeve	4.6	11.3	2830	2255	1235	37	5ACCO6SC
2SHE24B1W	24	27 1/8	9 3/4	25	1/4	1150	Ball	3.7	11.7	3240	2485	1110	38	5ACCO6SC
SINGLE SPEED														
2SHE18B1	18	21 1/8	12	19	1/4	1750	Sleeve	4.4	14.3	2590	2190	1705	31	—
2SHE20B1X	20	23 1/8	11 5/8	21	1/4	1735	Sleeve	4.3	14.4	2955	2450	1960	33	—
2SHE20C1	20	23 1/8	11 5/8	21	1/3	1710	Sleeve	4.9	16.9	3635	3115	2760	36	—
2SHE24B1X	24	27 1/8	10	25	1/4	1150	Sleeve	3.2	10.7	3270	2515	1205	39	—
2SHE24C1G	24	27 1/8	10 1/2	25	1/3	1120	Sleeve	3.6	12.1	3970	3240	1900	47	—
2SHE20B1Y	20	23 1/8	11 1/6	21	1/4	1750	Ball	4.3	14.3	2985	2445	1965	33	—
2SHE30C1	30	33 1/8	13 1/3	31	1/3	850	Ball	4.4	13.5	6075	4195	2150	66	—
2SHE36D1	36	39 1/8	13 1/8	37	1/2	850	Ball	5.6	14.7	8225	6480	2935	77	—
TWO SPEED														
2SHE24C1H	24	27 1/8	10 1/2	25	1/3	1140/1075	Sleeve	3.7	11.8/11.3	3985/3760	3255/2995	1950/1563	42	5ACCO2SC

(*) Performance certified is for installation type A, Free Inlet, Free Outlet. Speed (RPM) shown is nominal. Performance is based on actual speed of test. Performance ratings include the effects of guard and shutter.

(**) The sound ratings shown are loudness values in fan sones at 5 ft. (1.5mm) in a hemispherical free field calculated per AMCA Standard 301. Values shown are for Installation Type A, Free Inlet hemispherical sone levels.

Two-Speed Fan Switch (2ACCO2SW)

Designed for two-speed fans, this switch mounts easily on a standard 4 x 2" handy box.

- 115V 60 Hz
- DPDT (off center)
- 3/4 HP rating
- For use with Model No. 2SHE24C1H



Direct Drive Propeller Fans

Corrosion-Resistant Shutter Fans

Corrosion-resistant shutter fans are designed for use in corrosive atmospheres such as chemical plants, manufacturing facilities, poultry operations and swine confinement operations. They can be used for applications containing non-hazardous concentrations of ammonia, carbon tetrachloride, detergent, dimethyl formamide, methylene chloride, mineral oil, sodium chloride, sodium hydroxide, acetic acid, hydrochloric acid, nitric acid, phosphoric acid and sulfuric acid. They are not designed for laboratory hood exhausts.

Features and Specifications

- Fiberglass shutter and fiberglass reinforced polypropylene fan blades resist fumes from hydrogen sulfide and ammonia
- Corrosion-resistant stainless steel pivots and hardware
- Epoxy coated wire guards comply with OSHA regulations
- Air deliveries are based on AMCA test codes
- Totally enclosed, epoxy coated, 115V motors are not speed controllable
- Shipped completely assembled

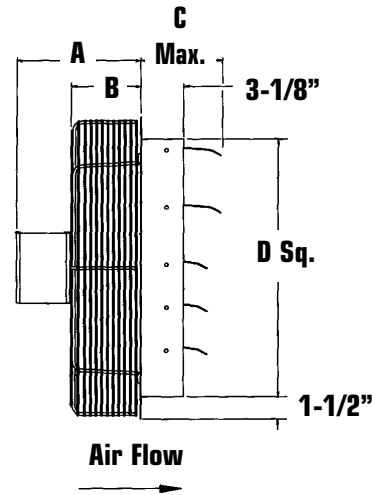
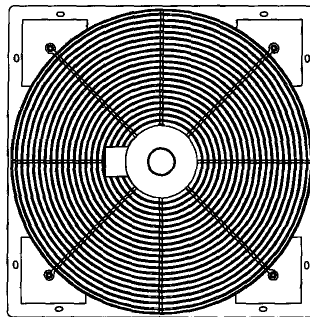

Fantech, Inc. and Systemair Mfg. Inc. certify that the Corrosion-Resistant Shutter Fans shown herein are licensed to bear the AMCA Seal. The ratings shown are based on tests and procedures performed in accordance with AMCA Publication 211 and AMCA Publication 311 and comply with the requirements of the AMCA Certified Ratings Program.

Model No.	Prop. Dia. (In.)	Square Opening Required (In.)	Dimensions (In.)			
			A	B	C	D
2SCR1061	10	10-1/2	8	3-1/4	5-1/4	10
2SCR1231	12	13	8-3/4	3-1/4	6-1/2	12
2SCR16A1	16	17	8-3/4	3-1/4	6-1/2	16
2SCR18B1	18	19	12	4-1/2	6-1/2	18
2SCR20C1	20	21	11-1/2	4	6-1/2	20
2SCR24D1	24	25	11-3/4	4	6-1/2	24

Model No.	Prop. Dia. (In.)	HP	Nominal RPM	Full Load Amps	Sones @ 5 Ft 0.0" SP	CFM Air Delivery				Ship Wt. (Lbs.)
						0.0" SP	0.125" SP	0.250" SP	0.375" SP	
2SCR1061	10	1/20	1625	1.9	12.3	524	379	199	—	19
2SCR1231	12	1/8	1645	1.9	13.4	1100	799	636	451	20
2SCR16A1	16	1/6	1535	2.1	15.7	2005	1678	1069	764	24
2SCR18B1	18	1/4	1120	4.1	12.5	2790	1961	1427	604	31
2SCR20C1	20	1/3	1110	4.9	13.7	3642	2838	2121	2120	36
2SCR24D1	24	1/2	1115	6.7	17.4	4876	4197	2562	2168	45

(*) Performance certified is for installation type A: Free Inlet, Free Outlet. Speed (RPM) shown is nominal. Performance is based on actual speed of test. Performance ratings include the effects of shutter and guard.

(**) The sound ratings shown are loudness values in fan sones at 5 ft. (1.5m) in a hemispherical free field calculated per AMCA Standard 301. Values shown are for Installation Type A, hemispherical sone levels.

Direct Drive Propeller Fans

7" to 24" Guard Mounted Exhaust Fans

Guard mounted exhaust fans are widely used for ventilating.

Features and Specifications

- Designed for low pressure applications of up to 0.125" SP
- Steel wire intake guard has four mounting loops to make installation easy, and baked-on gray polyester finish to help resist corrosion
- Guard complies with OSHA regulations

- Automatic shutter is optional
- Mounts vertically or horizontally
- Deep pitch aluminum propeller
- Totally enclosed, 115V, 60 Hz motor
- Mounting screws included

NOTE: Not for use with speed control.

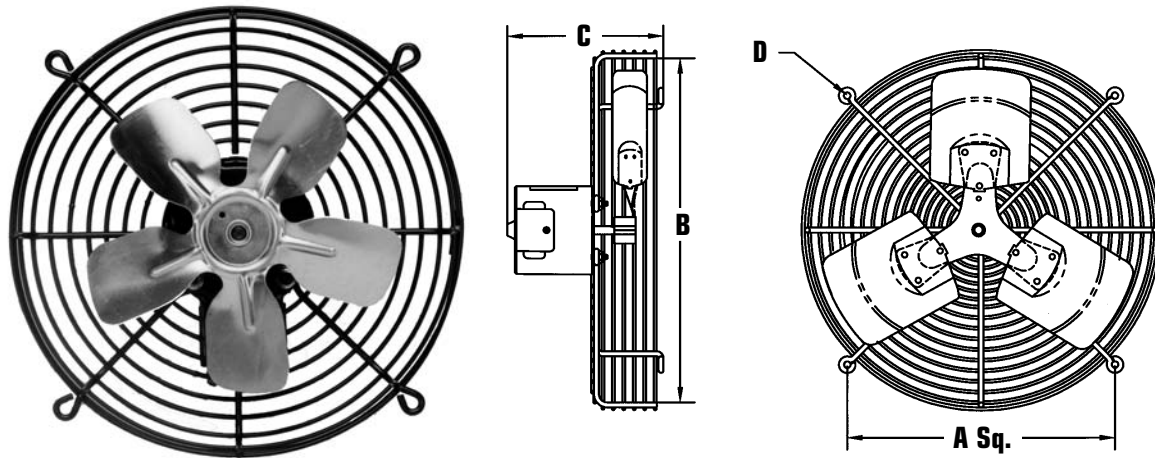

Model No.	Prop. Dia. (In.)	Dimensions (In.)				CFM Air Delivery		Sones @ 5 Ft.			Operating Amps	Ship Wt. (Lbs.)
		A	B	C	D	0.0" SP	0.125" SP	0.0" SP	HP	RPM		
2GMS0721	7	7-3/8	9-1/4	4-15/16	1/4	230	—	3.5	1/30	1550	1.4	6
2GMS1021	10	8-3/4	11	5-9/16	1/4	595	405	5.5	1/30	1550	1.4	6
2GMS1221	12	10-3/16	13	5-15/16	1/4	820	535	6.2	1/30	1550	1.4	8
2GMS1661	16	12-15/16	17-3/8	6-1/2	1/4	1060	585	8.0	1/20	1550	1.7	13
2GMS1881	18	15-3/8	20-1/8	12-1/2	5/16	2515	1780	12.1	1/4	1725	4.4	23
2GMS20B1	20	16-3/4	22-1/8	11-15/16	5/16	2600	1685	11.4	1/4	1725	4.0	25
2GMS24C1	24	19-5/8	26-1/8	10-3/16	5/16	3840	2690	10.8	1/3	1075	3.6	31

Direct Drive Propeller Fans

12" to 24" Medium and Heavy Duty Exhaust Fans

Medium and heavy duty exhaust fans are designed for general ventilation in dusty, dirty and grease- or moisture-laden environments.

Features and Specifications

- Wire guards and venturi panels have baked-on gray polyester finish to help resist corrosion
- Automatic shutter is optional

- Totally enclosed, sleeve bearing, 115V 60 Hz motor

Accessories (available separately)

- For more information, see Wall Fan Accessories



Air Flow

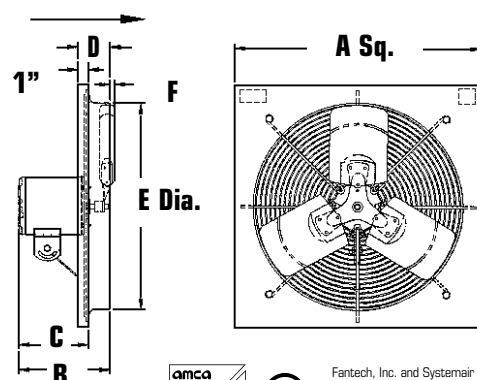

Fantech, Inc. and Systemair Mfg. Inc. certify that the 12" to 24" Medium and Heavy Duty Exhaust Fans shown herein are licensed to bear the AMCA Seal. The ratings shown are based on tests and procedures performed in accordance with AMCA Publication 211 and AMCA Publication 311 and comply with the requirements of the AMCA Certified Ratings Program.

Medium Duty Exhaust Fans

Model No.	Prop. Dia. (In.)	Panel Size (In.)	A Sq.	Dimensions (In.)				Nominal HP	Oper. RPM	Oper. Amps	Sones @ 5 Ft. 0.125" SP	CFM at SP Shown				Ship Wt. (lbs.)	Speed Controller Model No.	
				B	C	D	E					0.0" SP	0.125" SP	0.250" SP	0.375" SP			
SPEED CONTROLLABLE																		
2VLD1221	12	16x16	16	5 3/16	3 11/16	2 1/2	12 3/8	3/4	1/30	1550	1.4	7.8	845	665	315	—	11	5ACC03SC
2VLD1661	16	20x20	20	6 3/16	4 7/16	2 3/4	16 7/16	9/16	1/20	1520	1.6	13.6	1170	885	560	—	17	5ACC03SC
2VLD18B1	18	22x22	22	8	6 1/16	2 15/16	18 7/16	1 1/2	1/4	1150	3.9	10.4	2500	2130	1590	1025	28	5ACC06SC
2VLD20B1	20	24x24	24	9 5/8	7 1/2	3 3/16	20 1/2	1 1/16	1/4	1165	4.9	12.5	3440	2995	2310	1450	32	5ACC06SC
2VLD24B1	24	28x28	28	8 1/2	6	3 5/8	24 3/8	1/2	1/4	1150	4.1	12.8	3455	2985	2410	1580	35	5ACC06SC
SINGLE SPEED																		
2VLD18B1G	18	22x22	22	8 1/2	6	2 15/16	18 7/16	1	1/4	1150	4.5	16.0	3075	2850	2605	2320	28	—
2VLD20B1G	20	24x24	24	10 1/2	8 1/4	3 3/16	20 1/2	1 1/4	1/4	1730	4.5	16.3	3155	2840	2480	1990	30	—
2VLD24C1G	24	28x28	28	9	6 1/2	3 5/8	24 3/8	7/8	1/3	1120	5.3	13.7	4435	3945	3400	2505	37	—

Heavy Duty Exhaust Fans

Model No.	Prop. Dia. (In.)	Panel Size (In.)	A Sq.	Dimensions (In.)				Nominal HP	Oper. RPM	Oper. Amps	Watts	Sones @ 5 Ft. 0.125" SP	CFM at SP Shown				Ship Wt. (lbs.)
				B	C	D	HP						0.0" SP	0.125" SP	0.250" SP	0.375" SP	
2VHD12B1	12	16 x 16	16	10 1/8	2 1/2	12 3/8	1/4	1775	3.4	206	10.1	1190	1055	870	685	505	23
2VHD16B1	16	20 x 20	20	10 1/4	2 3/4	16 7/16	1/4	1735	4.4	354	16.5	2640	2370	2020	1460	1190	26
2VHD18B1	18	22 x 22	22	10 1/8	2 15/16	18 7/16	1/4	1740	4.3	321	17.4	2840	2490	2085	1622	1295	29
2VHD20B1W	20	24 x 24	24	10 3/8	3 3/16	20 1/2	1/4	1745	4.3	367	22	2970	2565	2110	1690	1335	31
2VHD20B1Y	20	24 x 24	24	10 3/8	3 3/16	20 1/2	1/3	1725	4.5	418	24	3510	3030	2535	2120	1735	34
2VHD20D1	20	24 x 24	24	10 3/4	3 3/16	20 1/2	1/2	1705	5.9	520	22	4245	3665	3085	2635	2135	40
2VHD24C1	24	28 x 28	28	10 3/4	3 5/8	24 3/8	1/3	1745	4.3	366	29	3849	3286	2746	2180	1630	41
2VHD24D1	24	28 x 28	28	11 1/4	3 5/8	24 3/8	1/2	1690	6.6	675	32	5545	4895	4219	3583	2827	45

(*) Performance certified is for installation type A: Free Inlet, Free Outlet. Speed (RPM) shown is nominal. Performance is based on actual speed of test. Performance ratings include the effects of shutter and guard.

(**) The sound ratings shown are loudness values in fan sones at 5 ft. (1.5m) in a hemispherical free field calculated per AMCA Standard 301. Values shown are for Installation Type A, hemispherical sone levels.

Direct Drive Propeller Fans

Stamped Aluminum Blade Venturi Exhaust Fans

Aluminum blade venturi exhaust fans are designed to achieve efficient, economical ventilation in industrial/commercial applications.

Features and Specifications

- Fans feature heavy duty venturi panel with a fixed-position motor base and rigid tubular supports
- Totally enclosed motor

- Shipped assembled and have stamped aluminum fan blades

NOTE: OSHA-compliant guards are required when fan is installed within 8.2 ft. (2.5M) of the floor, at working level, or within reach of personnel. Please review OSHA codes.

Accessories (available separately)

- For more information, see Wall Fan Accessories

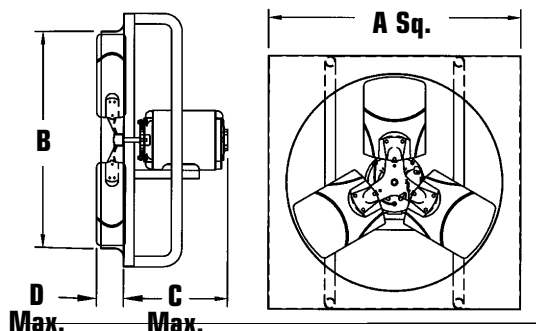
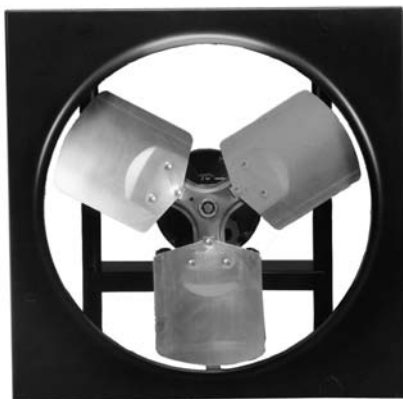

Fantech, Inc. and Systemair Mfg. Inc. certify that the Stamped Aluminum Blade Venturi Exhaust Fans shown herein are licensed to bear the AMCA Seal. The ratings shown are based on tests and procedures performed in accordance with AMCA Publication 211 and AMCA Publication 311 and comply with the requirements of the AMCA Certified Ratings Program.

Model No.	Prop. Dia. (In.)	A Sq.	Dimensions (In.)			Venturi Clearance Dia. (In.)	Intake Guards Model No.
			B	C	D		
115/230V, 60 HZ, SINGLE PHASE							
2STV12B2	12	16	12 3/8	10 5/8	2 3/4	14	1ACC12SG
2STV16B2	16	20	16 1/2	10	2 1/4	18	1ACC16SG
2STV18B2	18	22	18 1/2	10 5/8	2 3/16	20	1ACC18SG
2STV18C2	18	22	18 1/2	10 5/8	2 3/16	20	1ACC18SG
2STV20C2	20	24	20 1/2	9 15/16	2 3/16	22	1ACC20SG
2STV20D2	20	24	20 1/2	9 15/16	2 3/16	22	1ACC20SG
2STV24C2	24	28	24 3/8	9 5/8	3 1/8	26	1ACC24SG
2STV24D2	24	28	24 3/8	9 5/8	3 1/8	26	1ACC24SG
2STV30E2	30	34	30 1/2	10 1/4	3 11/16	32	1ACC30SG
208-220/440V, 60 HZ, 3-PHASE							
2STV20DY	20	24	20 1/2	9 15/16	2 3/16	22	1ACC20SG
2STV24DY	24	28	24 3/8	9 5/8	3 1/8	26	1ACC24SG
2STV30EY	30	34	30 1/2	10 1/4	3 11/16	32	1ACC30SG

Model No.	Prop. Dia. (In.)	HP	Nominal RPM	Full Load		No. of Blades	Sones@5 Ft.		CFM Air Delivery			Ship Wt. (lbs.)
				Amps	Watts		0.125" SP	0.0" SP	0.125" SP	0.250" SP	0.375" SP	
115/230V, 60 HZ, SINGLE PHASE												
2STV12B2	12	1/4	1750	5.1	290	3	12.8	1477	1329	1094	767	33
2STV16B2	16	1/4	1715	5.5	400	3	21	2512	2365	2172	1915	37
2STV18B2	18	1/4	1722	5.6	390	3	19.0	2958	2752	2521	2217	40
2STV18C2	18	1/3	1735	7.2	475	3	21	3348	3125	2876	2570	34
2STV20C2	20	1/3	1740	7.3	495	3	17.8	3664	3364	3071	2757	38
2STV18D2	20	1/2	1730	9.7	638	3	19.8	4386	4139	3880	3564	44
2STV24C2	24	1/3	1175	6.2	335	2	13.3	3931	3315	2513	1174	54
2STV24D2	24	1/2	1755	9.2	490	2	21	4348	3894	3406	2843	46
2STV30E2	30	3/4	1145	7.9	781	3	23	8615	7965	7263	6470	60
208-220/440V, 60 HZ, 3-PHASE												
2STV20DY	20	1/2	1715	2.2	513	3	19.5	4403	4158	3897	3565	43
2STV24DY	24	1/2	1725	2.2	672	3	30	5230	4891	4550	4200	40
2STV30EY	30	3/4	1160	3.0	783	3	23	8722	8104	7440	6724	55

(*) Performance certified is for installation type A: Free Inlet, Free Outlet. Speed (RPM) shown is nominal. Performance is based on actual speed of test. Performance ratings include the effects of shutter and guard.

(**) The sound ratings shown are loudness values in fan sones at 5 ft. (1.5m) in a hemispherical free field calculated per AMCA Standard 301. Values shown are for Installation Type A, hemispherical sone levels.

Direct Drive Propeller Fans

Cast Aluminum Blade Venturi Exhaust Fans

Cast aluminum blade venturi exhaust fans are designed to achieve efficient, economical ventilation in industrial/commercial applications.

Features and Specifications

- Fans feature heavy duty venturi panel with a fixed-position motor base and rigid tubular supports
- Totally enclosed motor

- Shipped completely assembled

NOTE: OSHA-compliant guards are required when fan is installed within 8.2 ft. (2.5M) of the floor, at working level, or within reach of personnel. Please review OSHA codes.

Accessories (available separately)

- For more information, see Wall Fan Accessories

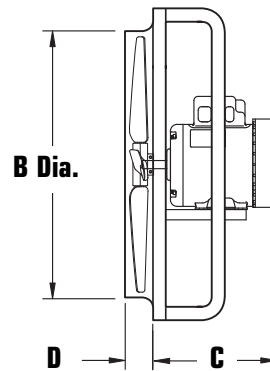
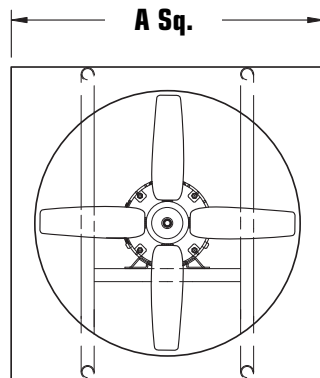

Fantech, Inc. and Systemair Mtg. Inc. certify that the Cast Aluminum Blade Venturi Exhaust Fans shown herein are licensed to bear the AMCA Seal. The ratings shown are based on tests and procedures performed in accordance with AMCA Publication 211 and AMCA Publication 311 and comply with the requirements of the AMCA Certified Ratings Program.

Model No.	Prop. Dia. (In.)	A Sq.	Dimensions (In.)				Venturi Clearance Dia. (In.)	Intake Guards Stock No.
			B	C	D			
115/230V, 60 HZ, SINGLE PHASE								
2CAV12B2	12	16	12-3/8	10-1/8	1-13/16	14	1ACC12SG	
2CAV16B2	16	20	16-1/2	10	2-5/16	18	1ACC16SG	
2CAV18C2	18	22	18-1/2	10-3/8	2-5/8	20	1ACC18SG	
2CAV20D2	20	24	20-1/2	9-15/16	2-15/16	22	1ACC20SG	
2CAV24D2	24	28	24-3/8	9-7/16	3-1/4	26	1ACC24SG	
2CAV24E2	24	28	24-3/8	9-7/16	3-1/4	26	1ACC24SG	
2CAV30E2	30	34	30-1/2	9-1/4	3-3/16	32	1ACC30SG	
208-220/440V, 60 HZ, 3-PHASE								
2CAV16BY	16	20	16-1/2	10	2-5/16	18	1ACC16SG	
2CAV18BY	18	22	18-1/2	10-3/8	2-5/8	20	1ACC18SG	
2CAV20DY	20	24	20-1/2	9-15/16	2-15/16	22	1ACC20SG	
2CAV24EY	24	28	24-3/8	9-7/16	3-1/4	26	1ACC24SG	
2CAV30EY	30	34	30-1/2	9-1/4	3-3/16	32	1ACC30SG	

Model No.	Prop. Dia. (In.)	HP	Nominal RPM	Full Load Amps	Watts	Sones @ 5 Ft. 0.0" SP	0.0" SP	CFM Air Delivery				Ship Wt. (lbs.)
								0.125" SP	0.250" SP	0.375" SP	0.500" SP	
115/230V, 60 HZ, SINGLE PHASE												
2CAV12B2	12	1/4	1762	5.0	250	11.4	1239	1110	937	757	—	27
2CAV16B2	16	1/4	1725	5.2	375	17.2	2561	2168	1692	1361	1140	40
2CAV18C2	18	1/3	1732	6.6	460	22	3257	2826	2370	1954	1595	40
2CAV20D2	20	1/2	1718	8.7	633	25	4400	3917	3320	2758	2310	46
2CAV24D2	24	1/2	1706	8.7	708	37	5918	5332	4712	4049	3295	49
2CAV24E2	24	3/4	1740	9.9	726	36	6621	5585	4937	4288	3600	56
2CAV30E2	30	3/4	1130	7.2	762	20	9902	8222	5756	—	—	65
208-220/440V, 60 HZ, 3-PHASE												
2CAV16BY	16	1/4	1737	1.4	325	17.2	2571	2164	1963	1352	1085	43
2CAV18BY	18	1/3	1736	1.4	360	22	3316	2875	2413	1990	1620	42
2CAV20DY	20	1/2	1756	1.8	501	25	4487	3974	3371	2828	2385	48
2CAV24EY	24	3/4	1725	2.6	640	39	6312	5711	5079	4433	3780	53
2CAV30EY	30	3/4	1150	2.9	745	21	9927	8257	5844	—	—	63

(*) Performance certified is for installation type A: Free Inlet, Free Outlet. Speed (RPM) shown is nominal. Performance is based on actual speed of test. Performance ratings include the effects of shutter and guard.

(**) The sound ratings shown are loudness values in fan sones at 5 ft. (1.5m) in a hemispherical free field calculated per AMCA Standard 301. Values shown are for Installation Type A, hemispherical sone levels.

Direct Drive Propeller Fans

12" to 24" Hazardous Location Exhaust Fans

Hazardous location cast exhaust fans are designed for heavy-duty ventilation in atmospheres containing flammable or explosive vapors, gases or dusts (per NEC 500).

Features and Specifications

- UL Listed (E206025) fans are for use in hazardous locations
- Motors are hazardous location for Class I, Group D; and Class II, Groups E, F and G applications
- Motorized shutters are not recommended.

NOTE: OSHA-compliant guards are required when fan is installed within 8.2 ft. (2.5M) of the floor, at working level, or within reach of personnel. Please review OSHA codes.

NOTE: Units are not recommended where motor or blades will accumulate paint. Consult local ventilation or fire inspector for code requirements.

Accessories (available separately)

- For more information, see Wall Fan Accessories

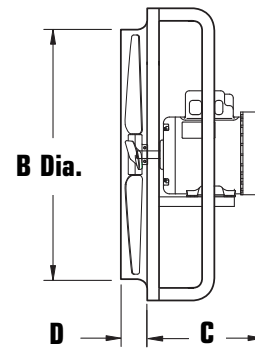
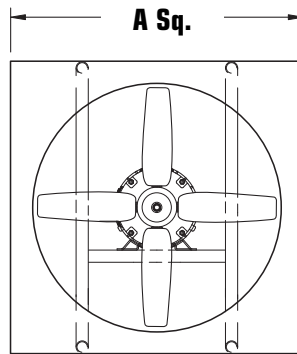

Fantech, Inc. and Systemair Mfg. Inc. certify that the 12" to 24" Hazardous Location Exhaust Fans shown herein are licensed to bear the AMCA Seal. The ratings shown are based on tests and procedures performed in accordance with AMCA Publication 211 and AMCA Publication 311 and comply with the requirements of the AMCA Certified Ratings Program.

Model No.	Prop. Dia. (In.)	A Sq.	Dimensions (In.)			Venturi Clearance Dia. (In.)	Intake Guards Model No.
			B	C	D		
115V, 60 HZ, SINGLE PHASE							
2CAV12BK	12	16	12-3/8	11-1/4	1-13/16	14	1ACC12SG
2CAV16BK	16	20	16-1/2	11-1/16	2-3/8	18	1ACC16SG
2CAV18CK	18	22	18-1/2	11-3/4	2-5/8	20	1ACC18SG
115/230V, 60 HZ, SINGLE PHASE							
2CAV20DK	20	24	20-1/2	12 3/8	2-15/16	22	1ACC20SG
2CAV24DK	24	28	24-3/8	12-1/16	3-3/8	26	1ACC24SG
2CAV24EK	24	28	24-3/8	12-1/16	3-3/8	26	1ACC24SG

Model No.	Prop. Dia. (In.)	HP	Nominal RPM	Full Load Amps	Watts	Sones @ 5 Ft. 0.0" SP	CFM Air Delivery					Ship Wt. (lbs.)
							0.0" SP	0.125" SP	0.250" SP	0.375" SP	0.500" SP	
115V, 60 HZ, SINGLE PHASE												
2CAV12BK	12	1/4	1774	3.4	200	12.1	1217	1104	925	626	513	42
2CAV16BK	16	1/4	1742	3.9	345	16.9	2547	2151	1681	1339	1064	44
2CAV18CK	18	1/3	1736	6.0	420	22	3247	2807	2368	1930	1575	41
115/230V, 60 HZ, SINGLE PHASE												
2CAV20DK	20	1/2	1731	8.8	614	25	4438	3937	3302	2775	2329	49
2CAV24DK	24	1/2	1720	8.8	687	38	5969	5364	4745	4079	3387	51
2CAV24EK	24	3/4	1747	10.6	766	37	6267	5640	4991	4359	3675	57

Direct Drive Propeller Fans

Hazardous Location Ring Fans and Flanged Ring Fans

12" to 30" Hazardous Location Cast Aluminum Ring Fans

Hazardous location cast aluminum ring fans are designed for heavy-duty ventilation in atmospheres containing flammable or explosive vapors, gases or dusts (per NEC 500).

Features and Specifications

- Heavy steel circular frame with ample mounting holes and a fixed-position motor base attached to rigid tubular supports
- Spark-resistant cast aluminum fan blades
- UL Listed (E206025) fans are for use in hazardous locations
- Motors are hazardous location for Class I, Group D; and Class II, Groups E, F and G applications

- Motorized shutters are not recommended.

NOTE: OSHA-compliant guards are required when fan is installed within 8.2 ft. (2.5M) of the floor, at working level, or within reach of personnel. Please review OSHA codes.

NOTE: Consult local ventilation or fire inspector for code requirements. Units are not for use where motor or blades will accumulate paint residue. Electrically ground all components in hazardous location system.

Accessories (available separately)

- For more information, see Wall Fan Accessories

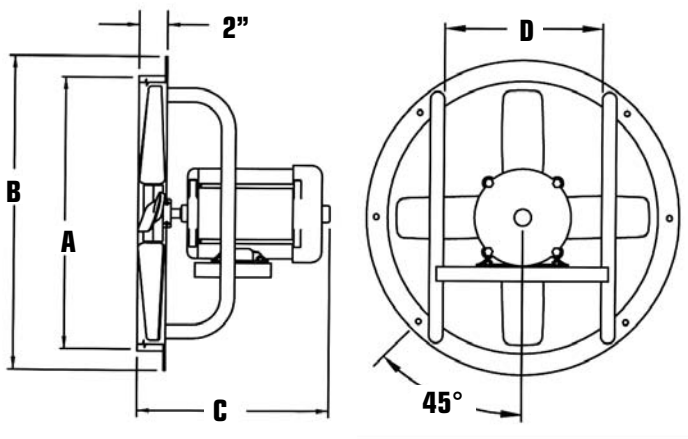

Fantech, Inc. and Systemair Mfg. Inc. certify that the Hazardous Location Ring Fans and Flanged Ring Fans shown herein are licensed to bear the AMCA Seal. The ratings shown are based on tests and procedures performed in accordance with AMCA Publication 211 and AMCA Publication 311 and comply with the requirements of the AMCA Certified Ratings Program.

Model No.	Prop. Dia. (In.)	Outside Dim. (In.)	Venturi Clearance Dia. (In.)	A	B	C	D	No. of Blades
115/230V, 60 HZ, SINGLE PHASE								
2HLE12BK	12	16-1/4	13-1/2	13-1/4	16-1/4	12-5/8	7	6
2HLE16BK	16	20-1/4	17-1/2	17-1/4	20-1/4	13-7/8	11-1/4	4
2HLE18BK	18	22-1/4	19-1/2	19-1/4	22-1/4	13-5/8	11-1/4	4
2HLE20BK	20	24-1/2	21-1/2	21-1/4	24-1/4	13-1/2	11-1/4	4
2HLE24BK	24	28-1/4	25 1/2	25-1/4	28-1/4	13-3/4	11-1/4	4
115/230V, 60 HZ, SINGLE PHASE								
2HLE24DL	24	28-1/4	25-1/2	25-1/4	28-1/4	13-7/8	11-1/4	4
2HLE30EL	30	33-1/2	30-1/2	30-1/2	33-1/2	15-1/8	11-1/4	6

Model No.	Prop. Dia. (In.)	HP	Nominal RPM	Full Load Amps	Watts	Sones@ 5 Ft. 0.0" SP	CFM Air Delivery					Ship Wt. (lbs.)
							0.0" SP	0.125" SP	0.250" SP	0.375" SP	0.500" SP	
115/230V, 60 HZ, SINGLE PHASE												
2HLE12BK	12	1/4	1772	4.5	193	14.2	900	699	585	312	—	45
2HLE16BK	16	1/4	1740	4.5	320	22	1979	1571	1301	1093	668	45
2HLE18BK	18	1/4	1745	4.5	313	23	2376	1937	1519	1335	868	43
2HLE20BK	20	1/4	1750	4.5	290	23	2560	2014	1502	1166	553	45
2HLE24CK	24	1/3	1747	6.4	383	29	3344	2697	2077	1519	868	54
115/230V, 60 HZ, SINGLE PHASE												
2HLE24DL	24	1/2	1725	9.0/4.5	667	35	4695	4082	3397	2738	2214	50
2HLE30EL	30	3/4	1157	9.6/4.8	653	28	7122	6093	5002	3799	2707	78

(*) Performance certified is for installation type A: Free Inlet, Free Outlet. Speed (RPM) shown is nominal. Performance is based on actual speed of test. Performance ratings include the effects of shutter and guard.

(**) The sound ratings shown are loudness values in fan sones at 5 ft. (1.5m) in a hemispherical free field calculated per AMCA Standard 301. Values shown are for Installation Type A, hemispherical sone levels.

Direct Drive Propeller Fans

Ring Fans and Flanged Ring Fans

6", 9" and 12" Diameter Ring Fans

Ring fans are designed for exhausting and cooling operations.

Features and Specifications

- Totally enclosed, shaded pole, 115V 60 Hz motor
- Units have heavy gauge steel angle frame with baked-on gray polyester finish. Galvanized steel ring on model numbers 2FRF0641, 2FRF0931 and 2FRF1221

Accessories (available separately)

- For more information, see Wall Fan Accessories

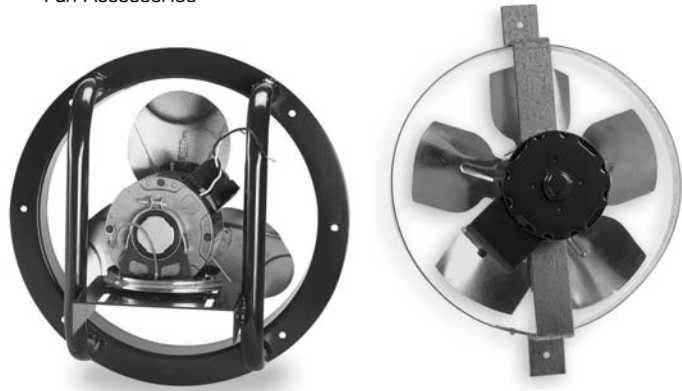

Model No.	Prop. Dia. (In.)	CFM @ 0.0" SP	HP	Full Load Amps	Motor Enclosure	Junction Box	Leads	Mounting Holes OC (In.)	Ship Wt. (lbs.)
2FRF0641	6	150	1/100	0.72	TE	YES	12	11 3/8	3.3
2FRF0931	9	290	1/70	0.74	TE	YES	12	11 1/4	5.6
2FRF1221	12	665	1/30	1.40	TE	YES	6	13 7/8	6.6
2FRF1261	12	1075	1/20	1.50	TE	YES	6	14 5/8	19.0

Reversible 12" to 24" Direct-Drive Exhaust & Supply Fans

Reversible direct-drive exhaust and supply fans are designed for exhaust or intake ventilating applications.

Features and Specifications

- Fans have 115V 60 Hz totally enclosed, thermally protected, ball bearing motors on resilient mounts
- Wall mounted rigid steel frames have deep venturi and 1" wide flanges
- Frames have charcoal gray polyester finish

- Reversing switch for remote mounting included
- Stamped aluminum propeller

NOTE: OSHA-compliant guards are strongly recommended when fan is installed within 8.2 ft. (2.5M) of the floor, at working level, or within reach of personnel. Review OSHA codes.

Accessories (available separately)

- For more information, see Wall Fan Accessories

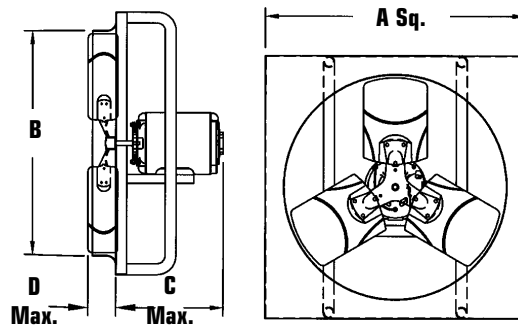

Model No.	Prop. Dia. (In.)	Dimensions (In.)				Dia. Opening Required (In.)	HP	RPM	Oper. Amps	0.0" SP	CFM Air Delivery (Exhaust/Supply)			Ship Wt. (lbs.)	Optional Intake Guard Model No.
		A	B	C	D						0.125" SP	0.250" SP	0.375" SP		
2DRV12B1	12	16	12 3/8	8 3/4	2	14	1/4	1725	3.9	1570/1260	1385/1195	1135/1095	755/770	31.0	1ACC12SG
2DRV16B1	16	20	16 1/2	8 3/8	1 3/4	18	1/4	1725	3.9	1885/1605	1640/1435	1370/1325	1020/1150	30.0	1ACC16SG
2DRV16C1	16	20	16 1/2	8 3/8	2 3/8	18	1/3	1725	4.4	2630/2200	2430/2010	2215/1880	1725/1730	39.0	1ACC18SG
2DRV18C1	18	22	18 1/2	8 3/4	1 7/8	20	1/3	1725	4.5	3255/2930	2990/2690	2705/2545	2375/2370	36.0	1ACC20SG
2DRV20C1	20	24	20 1/2	8 3/8	2 1/8	22	1/3	1725	5.0	3960/3440	3680/3170	3305/2970	2880/2645	41.0	1ACC24SG
2DRV24D1	24	28	24 3/8	8 1/2	2 5/8	26	1/2	1725	5.6	4495/4290	4130/3925	3720/3570	3285/3180	49.0	1ACC30SG

Belt Drive Propeller Fans

36" Reversible Belt-Drive Exhaust & Supply Fan

Belt-drive exhaust/supply fans are designed for use in factories, foundries, laundries and farm buildings.

Features and Specifications

- Specially designed fan blade delivers high volume of air for intake or exhaust applications
- Up to 10,080 CFM at 0.500" SP intake or exhaust with motor reversing switch
- Self-aligning, heavy-duty, pre-lubricated ball-bearing pillow blocks permit mounting in wall, air duct, ceiling or roof
- Satisfactory operation in duct systems up to 1/2" SP
- 36" diameter, 8-blade, statically balanced steel propeller has split taper bushing
- Four blades pull in outside air when operated in intake direction. Four blades expel inside air when operated in the exhaust direction



- 7/8" diameter fan blade shaft
- Heavy-duty, 18-gauge venturi panel
- Motors are heavy-duty, ball-bearing, single or three phase
- Motor reversing switch included when fan is ordered complete with motor and drive

Accessories (available separately)

- For more information, see Wall Fan Accessories
- **WARNING: OSHA-compliant guards are required when fan is installed within 8.2 ft. (2.5M) of floor, working level or within reach of personnel. Review OSHA codes.**
- Intake guard.
- Wall collar.
- Weatherhood.
- Disconnect Switches.

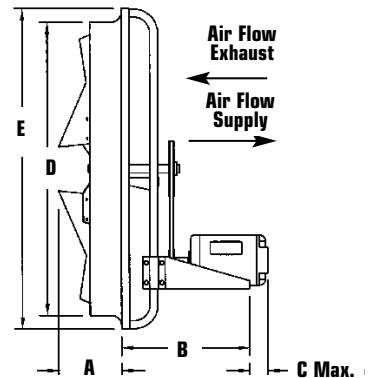

Model No.	Prop. Dia. (In.)	Dimensions (In.)					Max Ship Wt. (lbs.)	Optional Accessories			
		A	B	C	D	E		Intake Guard Model No.	Wall Collar Model No.	Motorized Damper Model No.	Weatherhood Model No.
1SDR36	36	4	16	4-3/4	36-1/2	40	158	1ACC36SG	1ACC36WC	1ACC36MD	1ACC36WH

Model No.	CFM Air Delivery								Dripproof Capacitor Motor 115/230V, 60 Hz	Totally Enclosed Capacitor Motor 115/230V, 60 Hz	Totally Enclosed 3-Phase Motor 208-220/440V, 60 Hz
	HP	RPM	TS (FPM)	0.0" SP	0.125" SP	0.250" SP	0.375" SP	0.500" SP			
1SDR36	1/2	490	4618	9360	7340	5720	4050	—	1SDR36DB	1SDR36D2	1SDR36DY
	3/4	575	5419	10580	8910	7380	5940	3600	1SDR36EB	1SDR36E2	1SDR36EY
	1	650	6126	11700	10220	8690	7560	5940	1SDR36FB	1SDR36F2	1SDR36FY
	1 1/2	765	7210	13140	11930	10490	9450	8460	1SDR36GB	1SDR36G2	1SDR36GY
	2	830	7822	14490	13410	12150	10800	10080	1SDR36HB	1SDR36H2	1SDR36HY*

* 230/460V, 60 Hz motor

Typical Specifications:

Reversible Axial Belt-Drive Exhaust and Supply Fans

Reversible fans shall be axial belt-drive type. The propeller shall be constructed of steel. Propellers shall be statically balanced. The fan housing shall be constructed of steel with a rigid steel support structure and coated with a durable, baked-on polyester powder coat finish. Motors shall be readily accessible for maintenance. Steel shafts shall be turned, ground-polished and mounted in permanently sealed and lubricated ball bearings. Bearings shall be selected for a minimum life (L50) in excess of 200,000 hours at maximum cataloged operating speed. Drives shall be sized for a minimum of 150% of driven horsepower. Pulleys shall be fully machined cast iron type, keyed and securely attached to the fan and motor shafts. Each fan shall bear a permanently affixed manufacturer's nameplate containing model number and carry a one-year warranty. Fans shall be Fantech Model 36" Reversible Belt-Drive Exhaust & Supply Fan as manufactured by Systemair Mfg. Inc., Lenexa, Kansas.

Belt Drive Propeller Fans

Standard Duty Belt-Drive Exhaust Fans

Standard duty belt-drive exhaust fans are designed for use with light to medium duty applications such as factories, warehouses, foundries and laundries.

Agency Listing

- All ventilators are UL Standard 705 listed
- Ventilators are CSA listed according to Standard C22.2 No. 113-M1984 (Fans & Ventilators)

Features and Specifications

- Vertical mount air exhaust, but can be used for horizontal mount air supply
- Computer-designed, 5-blade steel propeller
- Deep drawn steel venturi frame for maximum performance
- Fan shaft has 1" ball bearings and is self-aligning and pre-lubricated

- 1" shaft is stepped down to 7/8" to match fan blade and sheaves
- Tubular steel supports designed for rigid construction
- Adjustable motor mounts permit easy belt adjustment

Accessories (available separately)

- For more information, see Wall Fan Accessories
- Intake guard.
WARNING: OSHA-compliant guards are required when fan is installed within 8.2 ft. (2.5M) of floor, working level or within reach of personnel. Review OSHA codes.
- Wall collar.
- Weatherhood.
- Dampers.
- Disconnect Switches.

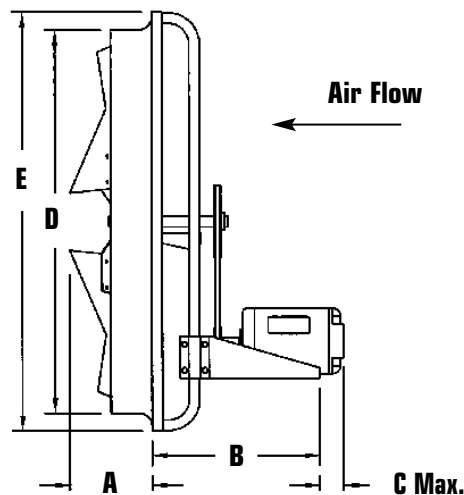

Fantech, Inc. and Systemair Mfg. Inc. certify that the Standard Duty Belt-Drive Exhaust Fans shown herein are licensed to bear the AMCA Seal. The ratings shown are based on tests and procedures performed in accordance with AMCA Publication 211 and AMCA Publication 311 and comply with the requirements of the AMCA Certified Ratings Program.

Model No.	Prop. Dia. (In.)	Dimensions (In.)					Max Ship Wt. (Lbs.)	Optional Accessories			
		A	B	C	D	E		Wall Mount Intake Guard Model No.	Wall Collar Model No.	Damper Model No.	Weatherhood Model No.
1SDE24	24	5	16	2-1/4	24-3/8	28	100	1ACC24SG	1ACC24WC	1ACC24WD	1ACC24WH
1SDE30	30	6	16	2-1/4	30-1/2	34	140	1ACC30SG	1ACC30WC	1ACC30WD	1ACC30WH
1SDE36	36	8	16	2-1/4	36-1/2	40	155	1ACC36SG	1ACC36WC	1ACC36WD	1ACC36WH
1SDE42	42	8-1/2	16	4-3/4	42-3/4	46	185	1ACC42SG	1ACC42WC	1ACC42WD	1ACC42WH
1SDE48	48	10	16	6-1/8	48-3/4	54	200	1ACC48SG	1ACC48WC	1ACC48WD	1ACC48WH

Typical Specifications:

Standard Duty Belt-Drive Exhaust Fans

Standard duty belt-drive exhaust fans shall be axial belt-drive type. The propeller shall be constructed of steel. Propellers shall be statically balanced. The fan housing shall be constructed of steel with a rigid steel support structure and coated with a durable, baked-on polyester powder coat finish. Motors shall be readily accessible for maintenance. Steel shafts shall be turned, ground-polished and mounted in permanently sealed and lubricated ball bearings. Bearings shall be selected for a minimum life (L50) in excess of 200,000 hours at maximum cataloged operating speed. Drives shall be sized for a minimum of 150% of driven horsepower. Pulleys shall be fully machined cast iron type, keyed and securely attached to the fan and motor shafts. All fans shall bear the AMCA Certified Ratings Seal for sound and air performance. Each fan shall bear a permanently affixed manufacturer's nameplate containing model number and carry a one-year warranty. Fans shall be Fantech Model Standard Duty Belt-Drive Exhaust Fans as manufactured by Systemair Mfg. Inc., Lenexa, Kansas.

Belt Drive Propeller Fans

Standard Duty Belt-Drive Exhaust Fans

Model No.	HP	RPM	TS (FPM)	Max. BHP#	0.0" SP	0.125" SP	0.250" SP	0.375" SP	Dripproof 1-Phase Motor 115/230V, 60 Hz	Totally Enclosed 1-Phase Motor 115/230V, 60 Hz	Totally Enclosed 3-Phase Motor 208-220/440V, 60 Hz	
					CFM	CFM	CFM	CFM				Sonest†
1SDE 24	1/4	650	4084	0.32	5120	4195	2160	—	1SDE24BB*	1SDE24B2	1SDE24BY	
					—	12.7	—	—				
	1/3	710	4461	0.44	5595	4775	2830	1650	1SDE24CB*	1SDE24C2	1SDE24CY	
					—	13.6	—	—				
	1/2	835	5246	0.66	6580	5910	4970	3100	1SDE24DB	1SDE24D2	1SDE24DY	
					—	16.7	—	—				
	3/4	945	5937	0.93	7445	6870	6200	4800	1SDE24EB	1SDE24E2	1SDE24EY	
					—	19.2	—	—				
1SDE30	1/4	470	3691	0.27	6895	4950	—	—	1SDE30BB*	1SDE30B2	1SDE30BY	
					—	14.1	—	—				
	1/3	500	3927	0.35	7335	5605	2320	—	1SDE30CB*	1SDE30C2	1SDE30CY	
					—	14.3	—	—				
	1/2	585	4594	0.52	8585	7305	4750	—	1SDE30DB	1SDE30D2	1SDE30DY	
					—	16.1	—	—				
	3/4	670	5262	0.80	9830	8805	7120	4130	1SDE30EB	1SDE30E2	1SDE30EY	
					—	17.7	—	—				
	1	720	5655	0.96	10565	9615	8205	5945	1SDE30FB	1SDE30F2	1SDE30FY	
					—	19.5	—	—				
	1SDE36	1/3	415	3911	0.38	10160	7590	—	—	1SDE36CB*	1SDE36C2	1SDE36CY
						—	14.1	—	—			
1/2		485	4571	0.62	11875	9915	5045	—	1SDE36DB	1SDE36D2	1SDE36DY	
					—	18.1	—	—				
3/4		540	5089	0.88	13220	11490	8565	4215	1SDE36EB	1SDE36E2	1SDE36EY	
					—	22	—	—				
1		605	5702	1.20	14815	13300	11415	6600	1SDE36FB	1SDE36F2	1SDE36FY	
					—	26	—	—				
1 1/2		660	6220	1.53	16160	14805	13215	10400	1SDE36GB	1SDE36G2	1SDE36GY	
					—	30	—	—				
1SDE42	1/2	380	4178	0.57	14515	11040	—	—	1SDE42DB	1SDE42D2	1SDE42DY	
					—	15.4	—	—				
	3/4	430	4278	0.79	16425	13670	6645	—	1SDE42EB	1SDE42E2	1SDE42EY	
					—	18.9	—	—				
	1	460	5058	1.04	17570	15045	8350	4855	1SDE42FB	1SDE42F2	1SDE42FY	
					—	21	—	—				
	1 1/2	535	5882	1.51	20435	18345	15480	8530	1SDE42GB	1SDE42G2	1SDE42GY	
					—	27	—	—				
1SDE48	1/2	315	3958	0.49	17060	10790	—	—	1SDE48DB	1SDE48D2	1SDE48DY	
					—	15.3	—	—				
	3/4	370	4649	0.83	20040	15900	6450	—	1SDE48EB	1SDE48E2	1SDE48EY	
					—	21	—	—				
	1	400	5026	1.16	21665	18120	8860	3465	1SDE48FB	1SDE48F2	1SDE48FY	
					—	23	—	—				
	1 1/2	450	5655	1.50	24375	21345	15700	7640	1SDE48GB	1SDE48G2	1SDE48GY	
					—	28	—	—				
	2	470	5906	1.67	25455	22575	17615	9275	1SDE48HB	1SDE48H2	1SDE48HY	
					—	30	—	—				
	3	500	6283	3.59	29559	27362	24916	21812	—	—	1SDE48JY	
					—	25	—	—				

Performance certified is for installation type A: Free Inlet, Free Outlet. # Power rating (BHP) does not include transmission losses. Performance ratings do not include the effects of appurtenances (accessories). † The sound ratings are loudness in fan sones at 5 ft. (1.5m) in a hemispherical free field calculated per AMCA Standard 301. Values shown are for installation type A: free inlet hemispherical sone levels. * 115V, 60 Hz motor.

Belt Drive Propeller Fans

Standard Duty Belt-Drive Supply Fans

Standard duty belt-drive supply fans are designed for use with light to medium duty applications such as factories, warehouses, foundries and laundries.

Agency Listing

- All ventilators are UL Standard 705 listed
- Ventilators are CSA listed according to Standard C22.2 No. 113-M1984 (Fans & Ventilators)

Features and Specifications

- Vertical mount air supply, but can be used for horizontal mount air exhaust
- Computer-designed, 5-blade steel propeller
- Deep drawn steel venturi frame for maximum performance
- Fan shaft has 1" ball bearings and is self-aligning and pre-lubricated
- 1" shaft is stepped down to 7/8" to match fan blade and sheaves
- Tubular steel supports designed for rigid construction

- Recommended shutters designed to inhibit backflow when fan is off
- Adjustable motor mounts permit easy assembly with a variety of motor types

Accessories (available separately)

- For more information, see Wall Fan Accessories
- Intake guard.
WARNING: OSHA-compliant guards are required when fan is installed within 8.2 ft. (2.5M) of floor, working level or within reach of personnel. Review OSHA codes.
- Wall collar.
- Weatherhood.
- Dampers.
- Disconnect Switches.



Air Flow →

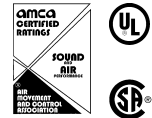
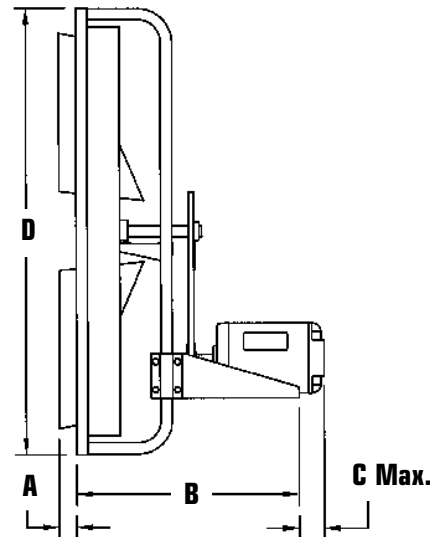

Fantech, Inc. and Systemair Mfg. Inc. certify that the Standard Duty Belt-Drive Supply Fans shown herein are licensed to bear the AMCA Seal. The ratings shown are based on tests and procedures performed in accordance with AMCA Publication 211 and AMCA Publication 311 and comply with the requirements of the AMCA Certified Ratings Program.

Model No.	Prop. Dia. (In.)	Dimensions (In.)				Max Ship Wt. (Lbs.)	Optional Accessories			
		A	B	C	D		Intake Guard Model No.	Wall Collar Model No.	Wall Mount Motorized Damper Model No.	Weatherhood Model No.
1SDS24	24	1-3/4	19-1/4	2-1/4	28	37	1ACC24SG	1ACC24WC	1ACC24MD	1ACC24WH
1SDS30	30	1-3/4	18-13/16	2-1/4	34	48	1ACC30SG	1ACC30WC	1ACC30MD	1ACC30WH
1SDS36	36	2-1/2	9-15/16	2-1/4	40	58	1ACC36SG	1ACC36WC	1ACC36MD	1ACC36WH
1SDS42	42	1-1/4	19-5/8	4-3/4	46	69	1ACC42SG	1ACC42WC	1ACC42MD	1ACC42WH
1SDS48	48	1-1/4	20-7/8	6-1/8	54	90	1ACC48SG	1ACC48WC	1ACC48MD	1ACC48WH

Typical Specifications:

Standard Duty Belt-Drive Supply Fans

Standard duty belt-drive supply fans shall be axial belt-drive type. The propeller shall be constructed of steel. Propellers shall be statically balanced. The fan housing shall be constructed of steel with a rigid steel support structure and coated with a durable, baked-on polyester powder coat finish. Motors shall be readily accessible for maintenance. Steel shafts shall be turned, ground-polished and mounted in permanently sealed and lubricated ball bearings. Bearings shall be selected for a minimum life (L50) in excess of 200,000 hours at maximum cataloged operating speed. Drives shall be sized for a minimum of 150% of driven horsepower. Pulleys shall be fully machined cast iron type, keyed and securely attached to the fan and motor shafts. All fans shall bear the AMCA Certified Ratings Seal for sound and air performance. Each fan shall bear a permanently affixed manufacturer's nameplate containing model number and carry a one-year warranty. Fans shall be Fantech Model Standard Duty Belt-Drive Supply Fans as manufactured by Systemair Mfg. Inc., Lenexa, Kansas.

Belt Drive Propeller Fans

Standard Duty Belt-Drive Supply Fans

Model No.	HP	RPM	TS (FPM)	Max. BHP#	0.0" SP	0.125" SP	0.250" SP	0.375" SP	Dripproof 1-Phase Motor 115/230V, 60 Hz	Totally Enclosed 1-Phase Motor 115/230V, 60 Hz	Totally Enclosed 3-Phase Motor 208-220/440V, 60 Hz
					CFM	CFM	CFM	CFM			
1SDS24	1/4	650	4084	0.32	5170	4005	2400	—	1SDS24BB*	1SDS24B2	1SDS24BY
					—	16.9	—	—			
	1/3	710	4461	0.44	5650	4570	3255	2120	1SDS24CB*	1SDS24C2	1SDS24CY
					—	17.5	—	—			
1/2	835	5246	0.66	6645	5715	4845	3345	1SDS24DB	1SDS24D2	1SDS24DY	
				—	18.5	—	—				
3/4	945	5937	0.98	7520	6725	5905	5070	1SDS24EB	1SDS24E2	1SDS24EY	
				—	20	—	—				
1SDS30	1/4	470	3691	0.27	6935	4730	—	—	1SDS30BB*	1SDS30B2	1SDS30BY
					—	12.8	—	—			
	1/3	500	3927	0.35	7380	5375	2650	—	1SDS30CB*	1SDS30C2	1SDS30CY
					—	12.7	—	—			
	1/2	585	4594	0.59	8630	6985	4335	2700	1SDS30DB	1SDS30D2	1SDS30DY
					—	14.6	—	—			
	3/4	670	5262	0.78	9885	8395	6810	4545	1SDS0EB	1SDS30E2	1SDS30EY
					—	16.4	—	—			
1	720	5655	0.93	10625	9215	7875	5420	1SDS30FB	1SDS0F2	1SDS30FY	
				—	18.5	—	—				
1SDS36	1/3	415	3911	0.38	9935	7245	—	—	1SDS36CB*	1SDS36C2	1SDS36CY
					—	12.7	—	—			
	1/2	485	4571	0.58	11610	9440	5255	—	1SDS36DB	1SDS36D2	1SDS6DY
					—	13.8	—	—			
	3/4	540	5089	0.88	12930	11000	7790	4705	1SDS36EB	1SDS36E2	1SDS36EY
					—	15.3	—	—			
	1	605	5702	1.11	14485	12790	11010	6880	1SDS36FB	1SDS36F2	1SDS36FY
					—	18.3	—	—			
1 1/2	660	6220	1.44	15800	14245	12610	9465	1SDS36GB	1SDS36G2	1SDS36GY	
				—	21	—	—				
1SDS42	1/2	380	4178	0.51	13775	9035	—	—	1SDS42DB	1SDS42D2	1SDS42DY
					—	15.8	—	—			
	3/4	430	4278	0.78	15585	12465	5790	—	1SDS42EB	1SDS42E2	1SDS42EY
					—	17.1	—	—			
	1	460	5058	1.05	16675	13835	7060	3925	1SDS42FB	1SDS42F2	1SDS42FY
					—	19.3	—	—			
	1 1/2	535	5882	1.49	19390	17115	12560	7395	1SDS42GB	1SDS42G2	1SDS42GY
					—	24	—	—			
1SDS48	1/2	315	3958	0.45	16370	7485	—	—	1SDS48DB	1SDS48D2	1SDS48DY
					—	15.9	—	—			
	3/4	370	4649	0.85	19230	14400	5800	—	1SDS48EB	1SDS48E2	1SDS48EY
					—	18.2	—	—			
	1	400	5026	1.17	20785	16385	8345	2280	1SDS48FB	1SDS48F2	1SDS48FY
					—	19.2	—	—			
	1 1/2	450	5655	1.53	23385	19575	10805	6825	1SDS48GB	1SDS48G2	1SDS48GY
					—	21	—	—			
2	470	5906	1.69	24425	20820	13425	8555	1SDS48HB	1SDS48H2	1SDS48HY	
				—	22	—	—				
3	500	6283	3.61	29624	27407	24721	21598	—	—	1SDS48JY	
				—	24	—	—				

Performance certified is for installation type A: Free Inlet, Free Outlet. # Power rating (BHP) does not include transmission losses. Performance ratings do not include the effects of appurtenances (accessories). † The sound ratings are loudness in fan sones at 5 ft. (1.5m) in a hemispherical free field calculated per AMCA Standard 301. Values shown are for installation type A: free outlet hemispherical sone levels. * 115V, 60 Hz motor.

Belt Drive Propeller Fans

Wall Mount Cabinet Belt-Drive Exhaust Fans

Wall Mount Cabinet Exhaust fans are designed for use with light to medium duty applications such as factories, warehouses, foundries and laundries. Each unit is shipped fully assembled with wall collar, guard and damper for easy installation.

Agency Listing

- All ventilators are UL Standard 705 listed
- Ventilators are CSA listed according to Standard C22.2 No. 113-M1984 (Fans & Ventilators)

Features and Specifications

- Shipped completely assembled with wall shutter and guard, and ready to install
- Wall-mounting brackets included
- All galvanized steel construction with baked-on powder-coated propellers

- Low RPM for quiet operation
- 60 Hz, single or three phase, TEAO ball-bearing type motors
- Variable pitch sheaves allow reduction of fan speed and air performance up to 25%
- Maximum inlet temperature is 120°F
- High-efficiency propellers and press-fit pillow block bearings
- Guards comply with OSHA Standard 1910.212, 1/2" max. opening requirement

Accessories (available separately)

- For more information, see Wall Fan Accessories
- Weatherhood.
- Disconnect Switches.



Fentech, Inc. and Systemair Mfg. Inc. certify that the Wall Mount Cabinet Belt-Drive Exhaust Fans shown herein are licensed to bear the AMCA Seal. The ratings shown are based on tests and procedures performed in accordance with AMCA Publication 211 and AMCA Publication 311 and comply with the requirements of the AMCA Certified Ratings Program.

Model No.	Prop. Dia. (In.)	Dimensions (In.)			Optional Accessories Weatherhood Model No.
		A	B	C	
1WMC24	24	28-1/4	28-1/4	24-1/4	1ACC24WH
1WMC30	30	34-1/4	34-1/4	25-1/4	1ACC30WH
1WMC36	36	40-1/4	40-1/4	26-1/4	1ACC36WH
1WMC42	42	46-1/4	46-1/4	28-1/4	1ACC42WH
1WMC48	48	54-1/4	54-1/4	28-1/4	1ACC48WH
1WMC54	54	60-1/4	60-1/4	47-3/4	1ACC54WH

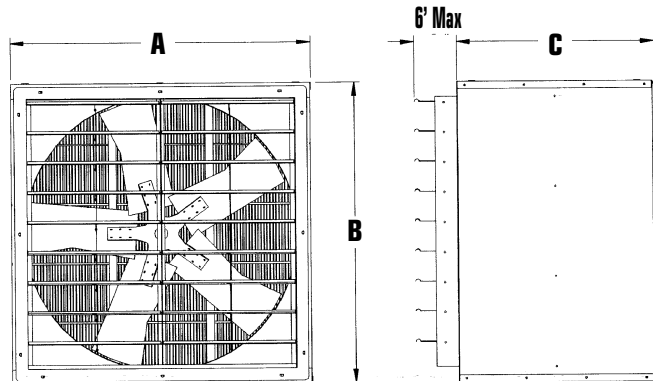

Belt Drive Propeller Fans

Wall Mount Cabinet Belt-Drive Exhaust Fans

Model No.	HP	RPM	TS (FPM)	Max. BHP#	0.0" SP	0.125" SP	0.250" SP	Totally Enclosed Capacitor Motor 115/230V, 60 Hz	Totally Enclosed 3-Phase Motor 208-220/440V, 60 Hz
					Sonest†	Sonest†	Sonest†	Total Ship Wt. (lbs.)	Total Ship Wt. (lbs.)
1WMC24	1/2	800	5026	0.56	5230	4410	3530	1WMC24D2	—
					—	16.1	—	123	—
1WMC24	3/4	920	5780	0.82	6015	5335	4545	—	1WMC24EY
					—	19	—	—	123
1WMC30	1/2	680	5341	0.81	8645	7430	5835	1WMC30E2	—
					—	16.7	—	176	—
1WMC30	1	750	5890	1.09	9535	8455	7130	—	1WMC30FY
					—	22	—	—	176
1WMC36	1	585	5513	0.99	12395	10640	8125	1WMC36F2	—
					—	20	—	196	—
1WMC36	1 1/2	677	6380	1.53	14345	12880	11160	—	1WMC36GY
					—	26	—	—	196
1WMC42	1	445	4893	0.88	14725	11115	6820	1WMC42F2	—
					—	18.4	—	242	—
1WMC42	1 1/2	530	5827	1.42	17540	14745	10800	—	1WMC42GY
					—	22	—	—	242
1WMC48	1	378	4750	0.88	18345	13910	6025	1WMC48F2	—
					—	23	—	288	—
1WMC48	2	480	6032	1.82	23295	20310	14720	—	1WMC48HY
					—	25	—	—	288
1WMC54	5	693	9797	5.74	38420	36168	33686	—	1WMC54KY
					—	46	—	—	635

Performance certified is for installation type A: Free Inlet, Free Outlet. # Power rating (BHP) does not include transmission losses. Performance ratings include the effects of shutter and guard. † The sound ratings are loudness in fan sones at 5 ft. (1.5m) in a hemispherical free field calculated per AMCA Standard 301. Values shown are for installation type A: free inlet hemispherical sone levels.

Typical Specifications:

Wall Mount Cabinet Exhaust Fans

Wall Mount Cabinet Exhaust fans shall be axial belt-drive type. The propeller shall be constructed of steel. Propellers shall be statically balanced. The fan housing shall be constructed of galvanized steel with a rigid steel support structure. Motors shall be readily accessible for maintenance. Steel shafts shall be turned, ground-polished and mounted in permanently sealed and lubricated ball bearings. Bearings shall be selected for a minimum life (L50) in excess of 200,000 hours at maximum cataloged operating speed. Drives shall be sized for a minimum of 150% of driven horsepower. Pulleys shall be fully machined cast iron type, keyed and securely attached to the fan and motor shafts. All fans shall bear the AMCA Certified Ratings Seal for sound and air performance. Each fan shall bear a permanently affixed manufacturer's nameplate containing model number and carry a one-year warranty. Fans shall be Fantech Model Wall Mount Cabinet Belt-Drive Exhaust Fans as manufactured by Systemair Mfg. Inc., Lenexa, Kansas.

Belt Drive Propeller Fans

Wall Mount Cabinet Belt-Drive Supply Fans

Wall Mount Cabinet Supply fans are designed for use with light to medium duty applications such as factories, warehouses, foundries and laundries. Each unit is shipped fully assembled with wall collar, guard and damper for easy installation.

Agency Listing

- All ventilators are UL Standard 705 listed
- Ventilators are CSA listed according to Standard C22.2 No. 113-M1984 (Fans & Ventilators)

Features and Benefits

- Shipped completely assembled with wall shutter and guard, and ready to install
- Wall-mounting brackets included
- All galvanized steel construction with baked-on powder-coated propellers

- Low RPM for quiet operation
- 60 Hz, single or three phase, TEAO ball-bearing type motors
- Variable pitch sheaves allow reduction of fan speed and air performance up to 25%
- Maximum inlet temperature is 120°F
- High-efficiency propellers and press-fit pillow block bearings
- Guards comply with OSHA Standard 1910.212, 1/2" max. opening requirement

Accessories (available separately)

- For more information, see Wall Fan Accessories
- Weatherhood.
- Disconnect Switches.

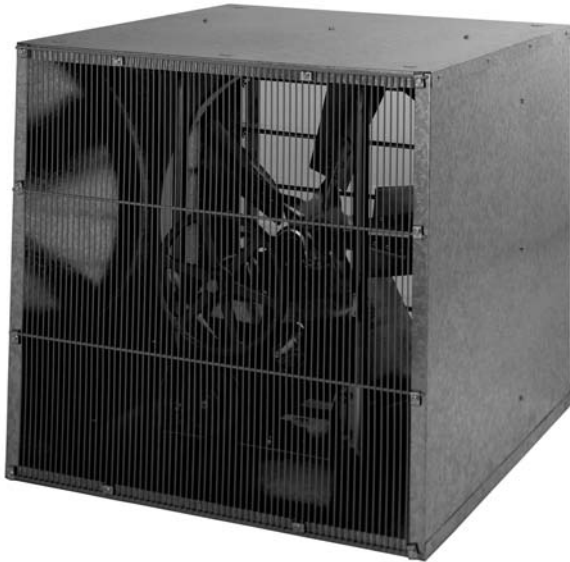

Fan shown mounted in wall



Fantech, Inc. and Systemair Mfg. Inc. certify that the Wall Mount Cabinet Belt-Drive Supply Fans shown herein are licensed to bear the AMCA Seal. The ratings shown are based on tests and procedures performed in accordance with AMCA Publication 211 and AMCA Publication 311 and comply with the requirements of the AMCA Certified Ratings Program.

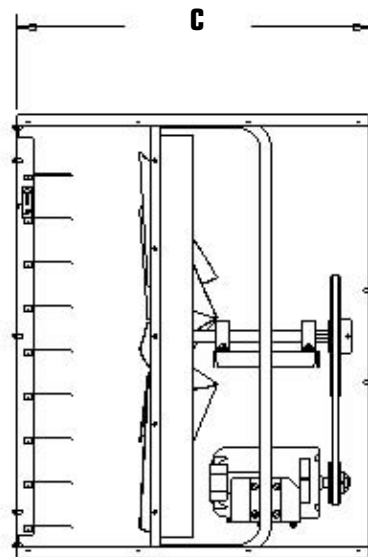
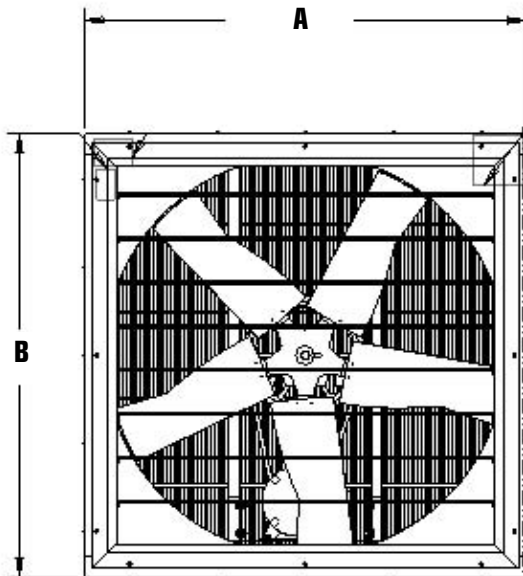

Belt Drive Propeller Fans

Wall Mount Cabinet Belt-Drive Supply Fans

Model No.	Prop. Dia. (In.)	Dimensions (In.)			Optional Accessories
		A	B	C	Weatherhood Model No.
1WMS24	24	28-1/4	28-1/4	30	1ACC24WH
1WMS36	36	40-1/4	40-1/4	32-1/4	1ACC36WH
1WMS48	48	54-1/4	54-1/4	33-3/4	1ACC48WH

Model No.	HP	RPM	TS (FPM)	Max. BHP#	0.0" SP	0.125" SP	0.250" SP	Totally Enclosed Capacitor Motor	Totally Enclosed 3-Phase Motor
					CFM	CFM	CFM	115/230V, 60 Hz	208-220/440V, 60 Hz
					Sonest†	Sonest†	Sonest†	Total Ship Wt. (lbs.)	Total Ship Wt. (lbs.)
1WMS24	1/2	800	5026	0.58	5554	4953	4153	1WMS24D2	—
					—	15.1	—	143	—
1WMS36	1	585	5513	1.09	13108	11265	9315	1WMS36F2	—
					—	19.0	—	208	—
	1 1/2	654	6164	1.50	14654	13005	11359	—	1WMS36GY
					—	23	—	—	212
1WMS48	2	480	6032	1.77	23578	20338	16229	—	1WMS48HY
					—	23	—	—	311

Performance certified is for installation type A: Free Inlet, Free Outlet. # Power rating (BHP) does not include transmission losses. Performance ratings include the effects of shutter and guard. † The sound ratings are loudness in fan sonets at 5 ft. (1.5m) in a hemispherical free field calculated per AMCA Standard 301. Values shown are for Installation Type A: Free Outlet hemispherical sone levels.

Typical Specifications:

Wall Mount Cabinet Supply Fans

Wall Mount Cabinet Supply fans shall be axial belt-drive type. The propeller shall be constructed of steel. Propellers shall be statically balanced. The fan housing shall be constructed of galvanized steel with a rigid steel support structure. Motors shall be readily accessible for maintenance. Steel shafts shall be turned, ground-polished and mounted in permanently sealed and lubricated ball bearings. Bearings shall be selected for a minimum life (L50) in excess of 200,000 hours at maximum cataloged operating speed. Drives shall be sized for a minimum of 150% of driven horsepower. Pulleys shall be fully machined cast iron type, keyed and securely attached to the fan and motor shafts. All fans shall bear the AMCA Certified Ratings Seal for sound and air performance. Each fan shall bear a permanently affixed manufacturer's nameplate containing model number and carry a one-year warranty. Fans shall be Fantech Model Wall Mount Cabinet Belt-Drive Supply Fans as manufactured by Systemair Mfg. Inc., Lenexa, Kansas.

Belt Drive Propeller Fans

Medium Duty Belt-Drive Exhaust Fans

Medium duty exhaust fans are designed for use in industrial exhaust ventilating systems in factories, warehouses, foundries, laundries and cooling towers.

Agency Listing

- All ventilators are UL Standard 705 listed

Ventilator Construction

- Available with a variety of motors up to 10 horsepower
- Efficient in duct installations with up to 1/2" static pressure
- Horizontal or vertical mounting
- Self-aligning, pre-lubricated, regreaseable ball-bearing pillow blocks
- Heavy-duty, statically balanced, fabricated steel propellers are safety locked to shaft

- Predrilled motor base accommodates standard NEMA motor frames of horsepower ratings specified

Accessories (available separately)

- For more information, see Wall Fan Accessories

- Intake guard.

WARNING: OSHA-compliant guards are required when fan is installed within 8.2 ft. (2.5M) of floor, working level or within reach of personnel. Review OSHA codes.

- Wall collar.
- Weatherhood.
- Dampers.
- Disconnect Switches.

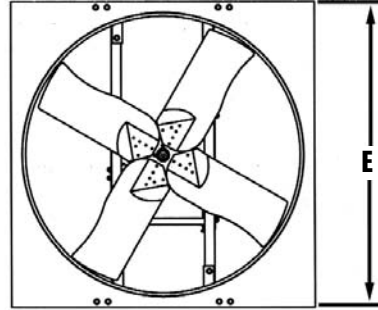
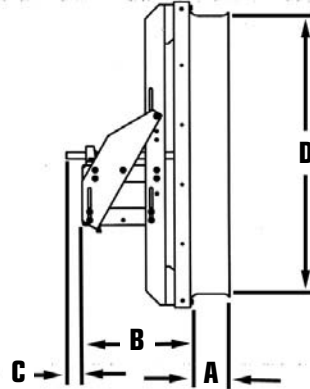

Fentech, Inc. and Systemair Mfg. Inc. certify that the Medium Duty Belt-Drive Exhaust Fans shown herein are licensed to bear the AMCA Seal. The ratings shown are based on tests and procedures performed in accordance with AMCA Publication 211 and AMCA Publication 311 and comply with the requirements of the AMCA Certified Ratings Program.

Model No.	Prop Dia. (In.)	Dimensions (In.)					Shaft Dia. (In.)	Max Ship Wt. (Lbs.)	Optional Accessories			
		A	B	C	D	E			Intake Guard Model No.	Wall Collar Model No.	Wall Mount Damper Model No.	Weatherhood Model No.
1MDE24	24	5	17	2-3/4	24-7/8	28	1	174	1ACC24SG	1ACC24WC	1ACC24WD	1ACC24WH
1MDE30	30	5-3/4	17	2-3/4	30-7/8	34	1	197	1ACC30SG	1ACC30WC	1ACC30WD	1ACC30WH
1MDE36	36	6-1/2	17	3	36-7/8	40	1-3/16	251	1ACC36SG	1ACC36WC	1ACC36WD	1ACC36WH
1MDE42	42	7	19-3/4	2-7/8	42-7/8	46	1-3/16	326	1ACC42SG	1ACC42WC	1ACC42WD	1ACC42WH
1MDE48	48	7	19-3/4	2-7/8	48-7/8	54	1-3/16	370	1ACC48SG	1ACC48HC	1ACC48WD	1ACC48WH
1MDE54	54	7	23-3/4	3-5/8	55	60	1-7/16	433	1ACC54SG	1ACC54HC	1ACC54WD	1ACC54WH
1MDE60	60	7	23-3/4	3-5/8	61	66	1-7/16	524	1ACC60SG	1ACC60HC	1ACC60WD	1ACC60WH

MOTOR SELECTION GUIDE

Dia. (In.)	HP	Open Dripproof		Totally Enclosed	
		Single Phase	Three Phase	Single Phase	Three Phase
24	1/3	CB	—	C2	CY
24-36	1/2	DB	—	D2	DY
24-42	3/4	EB	—	E2	EY
24-48	1	FB	FX	F2	FY
24-54	1-1/2	GB	GX	G2	GY

Dia. (In.)	HP	Open Dripproof		Totally Enclosed	
		Single Phase	Three Phase	Single Phase	Three Phase
30-60	2	HB	HX	H2	HY
36-60	3	—	JX	J2	JY
42-60	5	—	KX	—	KY
54-60	7-1/2	—	LX	—	LY
60	10	—	MX	—	MY

B = 115/230/60/1 Open Dripproof
 X = 208-220/440/60/3 Open Dripproof
 2 = 115/230/60/1 Totally Enclosed
 Y = 208-220/440/60/3 Totally Enclosed
 For fan with motor and drive package, add the two-digit motor HP, phase and enclosure code. Example: 1MDE24CB

Belt Drive Propeller Fans

Medium Duty Belt-Drive Exhaust Fans

Model No.	HP	RPM	TS (FPM)	Max. BHP#	0.0" SP CFM	0.125" SP CFM	0.250" SP CFM	0.375" SP CFM	0.500" SP CFM	Sones@ 0.250" SP†	Total Ship Wt. (lbs.)
1MDE24	1/3	833	5234	0.38	5687	5014	4083	—	—	13.9	145
	1/2	948	5956	0.57	6473	5901	5157	4229	—	17.2	146
	3/4	1000	6283	0.68	6828	6291	5617	4796	2140	18.8	150
	1	1204	7565	1.15	8220	7783	7296	6697	6027	27	151
	1 1/2	1395	8765	1.72	9525	9149	8753	8302	7774	31	162
1MDE30	1/2	728	5718	0.57	9013	7862	6235	—	—	17.2	162
	3/4	830	6519	0.87	10276	9270	8165	6244	—	19.2	167
	1	880	6911	1.02	10895	9947	8952	7381	—	21	168
	1 1/2	1052	8262	1.72	13024	12232	11434	10567	9300	30	179
	2	1170	9189	2.30	14485	13774	13058	12326	11485	33	199
1MDE36	1/2	515	4854	0.56	11756	9556	4467	—	—	19.1	213
	3/4	589	5551	0.91	13446	11660	9212	4334	—	21	217
	1	648	6107	1.14	14793	13090	11566	9761	8281	24	218
	1 1/2	680	6409	1.40	15523	14047	12065	9738	5003	26	229
	2	823	7756	2.33	18787	17600	16216	14480	12688	32	249
	3	942	8878	3.45	21504	20476	19363	18009	16468	37	274
1MDE42	3/4	437	4805	0.93	16350	13580	8753	3351	—	18.3	266
	1	450	4948	0.99	16837	14190	10130	3918	—	18.6	267
	1 1/2	550	6047	1.72	20578	18574	15817	12318	5889	22	278
	2	605	6652	2.28	22636	20854	18583	15648	9597	24	298
	3	692	7609	3.42	25891	24366	22581	20324	17699	32	323
	5	830	9126	5.77	31054	29801	28441	26878	25028	48	315
1MDE48	1	390	4901	1.15	20315	16318	10000	—	—	18	307
	1 1/2	453	5692	1.72	23597	20319	15577	—	—	21	318
	2	492	6182	2.30	25628	22659	18887	13298	—	23	338
	3	573	7200	3.45	29847	27344	24491	20760	—	30	363
	5	670	8419	5.50	34900	32779	30510	27899	24617	38	355
1MDE54	1 1/2	458	6475	1.65	25956	22363	16773	—	—	25	368
	2	505	7139	2.23	28620	25378	21561	13245	—	29	388
	3	578	8171	3.35	32757	29934	26974	22589	14835	36	413
	5	693	9797	5.70	39274	36925	34541	32007	28635	48	405
	7 1/2	780	11027	8.06	44205	42119	40017	37865	35526	55	433
1MDE60	2	422	6629	2.36	34374	29163	22869	13568	—	27	437
	3	483	7587	3.39	39343	34977	29683	23016	—	31	462
	5	572	8984	5.70	46592	43015	38783	34290	28932	40	454
	7 1/2	655	10288	8.60	53353	50266	46836	42897	39006	54	482
	10	710	11152	10.96	57833	54995	51947	48441	44780	64	500

Performance certified is for installation type A: Free Inlet, Free Outlet. # Power rating (BHP) does not include transmission losses. Performance ratings do not include the effects of appurtenances (accessories). † The sound ratings are loudness in fan sones at 5 ft. (1.5m) in a hemispherical free field calculated per AMCA Standard 301. Values shown are for Installation Type A, Free Inlet hemispherical sone levels.

Typical Specifications:

Medium Duty Belt-Drive Exhaust Fans

Medium duty belt-drive exhaust fans shall be axial belt-drive type. The propeller shall be constructed of steel. Propellers shall be statically balanced. The fan housing shall be constructed of steel with a rigid steel support structure and coated with a durable, baked-on polyester powder coat finish. Motors shall be readily accessible for maintenance. Steel shafts shall be turned, ground-polished and mounted in regreaseable, pillow block ball bearings. Bearings shall be selected for a minimum life (L50) in excess of 200,000 hours at maximum cataloged operating speed. Drives shall be sized for a minimum of 150% of driven horsepower. Pulleys shall be fully machined cast iron type, keyed and securely attached to the fan and motor shafts. All fans shall bear the AMCA Certified Ratings Seal for sound and air performance. Each fan shall bear a permanently affixed manufacturer's nameplate containing model number and carry a one-year warranty. Fans shall be Fantech Model Medium Duty Belt-Drive Exhaust Fans as manufactured by Systemair Mfg. Inc., Lenexa, Kansas.

Belt Drive Propeller Fans

Heavy Duty Belt-Drive Exhaust Fans

Heavy duty exhaust fans are designed for use in industrial exhaust ventilating systems in factories, warehouses, foundries, laundries and cooling towers.

Agency Listing

- All ventilators are UL Standard 705 listed

Ventilator Construction

- Available with a variety of motors up to 20 horsepower
- Efficient in duct installations with up to 1-1/2" static pressure
- Horizontal or vertical mounting
- Self-aligning, pre-lubricated, regreaseable ball-bearing pillow blocks
- Heavy-duty, statically balanced, fabricated steel propellers are safety locked to shaft

- Predrilled motor base accommodates standard NEMA motor frames of horsepower ratings specified

Accessories (available separately)

- For more information, see Wall Fan Accessories

- Intake guard.

WARNING: OSHA-compliant guards are required when fan is installed within 8.2 ft. (2.5M) of floor, working level or within reach of personnel. Review OSHA codes.

- Wall collar.
- Weatherhood.
- Dampers.
- Disconnect Switches.

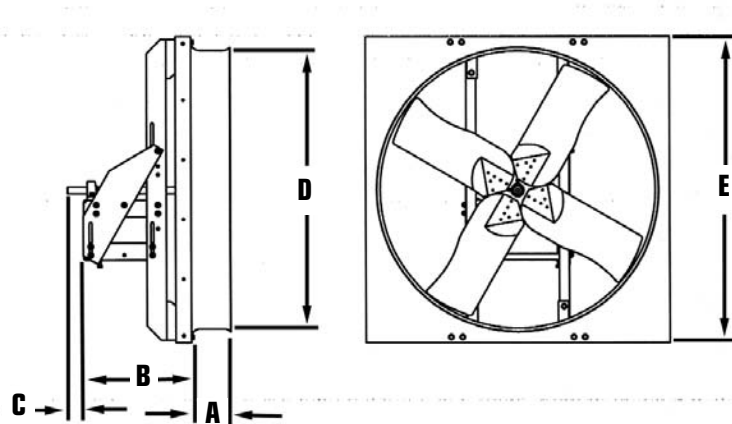

Fantech, Inc. and Systemair Mfg. Inc. certify that the Heavy Duty Belt-Drive Exhaust Fans shown herein are licensed to bear the AMCA Seal. The ratings shown are based on tests and procedures performed in accordance with AMCA Publication 211 and AMCA Publication 311 and comply with the requirements of the AMCA Certified Ratings Program.

Model No.	Prop. Dia. (In.)	Dimensions (In.)					Shaft Dia. (In.)	Max Ship Wt. (lbs.)	Optional Accessories			
		A	B	C	D	E			Intake Guard Model No.	Wall Collar Model No.	Wall Mount Damper Model No.*	Weatherhood Model No.
1HDE24	24	5	17	2-3/4	24-7/8	28	1	175	1ACC24SG	1ACC24WC	1ACC24MD	1ACC24WH
1HDE30	30	5-3/4	17	2-3/4	30-7/8	34	1	224	1ACC30SG	1ACC30WC	1ACC30MD	1ACC30WH
1HDE36	36	6-1/2	17	3	36-7/8	40	1-3/16	271	1ACC36SG	1ACC36WC	1ACC36MD	1ACC36WH
1HDE42	42	7	19-3/4	3	42-7/8	46	1-3/16	337	1ACC42SG	1ACC42WC	1ACC42MD	1ACC42WH
1HDE48	48	7	19-3/4	2-7/8	48-7/8	54	1-7/16	400	1ACC48SG	1ACC48HC	1ACC48MD	1ACC48WH
1HDE54	54	7	23-3/4	3-1/2	55	60	1-11/16	641	1ACC54SG	1ACC54HC	1ACC54MD	1ACC54WH
1HDE60	60	7	23-3/4	3-1/2	61	66	1-11/16	717	1ACC60SG	1ACC60HC	1ACC60MD	1ACC60WH

* Only use recommended motorized dampers

MOTOR SELECTION GUIDE

Dia. (In.)	HP	Open Dripproof		Totally Enclosed	
		Single Phase	Three Phase	Single Phase	Three Phase
24	1/2	DB	—	D2	DY
24-30	3/4	EB	—	E2	EY
24-36	1	FB	FX	F2	FY
24-42	1-1/2	GB	GX	G2	GY
30-48	2	HB	HX	H2	HY
30-54	3	—	JX	J2	JY

Dia. (In.)	HP	Open Dripproof		Totally Enclosed	
		Single Phase	Three Phase	Single Phase	Three Phase
36-60	5	—	KX	—	KY
42-60	7-1/2	—	LX	—	LY
48-60	10	—	MX	—	MY
54-60	15	—	NX	—	NY
60	20	—	PX	—	PY

B = 115/230/60/1 Open Dripproof
 X = 208-220/440/60/3 Open Dripproof
 2 = 115/230/60/1 Totally Enclosed
 Y = 208-220/440/60/3 Totally Enclosed
 For fan with motor and drive package, add the two-digit motor HP, phase and enclosure code. Example: 1HDE24DB

Belt Drive Propeller Fans

Heavy Duty Belt-Drive Exhaust Fans

Model No.	HP	RPM	TS (FPM)	Max. BHP [#]	0.0" SP CFM	0.125" SP CFM	0.250" SP CFM	0.375" SP CFM	0.500" SP CFM	0.625" SP CFM	0.750" SP CFM	1.00" SP CFM	Sones @ 0.250" SP [†]	Total Ship Wt. (lbs.)
1HDE24	1/2	1325	8325	0.58	6159	5720	5248	4651	3757	2064	—	—	21	146
	3/4	1517	9531	0.86	7051	6669	6272	5835	5281	4523	2907	—	26	154
	1	1670	10493	1.15	7762	7416	7061	6684	6259	5720	5025	—	31	157
	1 1/2	1910	12001	1.73	8878	8575	8269	7953	7619	7251	6819	5643	39	167
1HDE30	3/4	980	7697	0.79	8769	7667	6443	4892	2891	—	—	—	29	171
	1	1155	9071	1.22	10335	9402	8449	7319	6077	3855	—	—	33	174
	1 1/2	1260	9896	1.60	11275	10419	9557	8617	7500	6183	4165	—	36	184
	2	1460	11466	2.29	13066	12326	11586	10834	10009	9048	8099	—	47	197
1HDE36	3	1666	13084	3.45	14908	14261	13613	12963	12298	11582	10767	9078	60	224
	1	777	7323	1.15	14595	12967	10984	6258	—	—	—	—	28	224
	1 1/2	890	8388	1.72	16718	15313	13761	11720	6927	—	—	—	32	234
	2	979	9227	2.30	18389	17118	15762	14168	12010	7144	—	—	36	247
	3	1070	10084	3.45	21057	19950	18805	17565	16118	14273	11017	—	44	274
1HDE42	5	1329	12525	5.75	24964	24033	23087	22105	21060	19912	18576	14976	58	265
	1 1/2	818	8994	1.72	20331	18103	15752	12745	6447	—	—	—	35	283
	2	900	9896	2.34	22370	20341	18290	15816	12727	6488	—	—	39	296
	3	1030	11325	3.44	25601	23826	22063	20189	17929	15369	9523	—	51	323
	5	1222	13436	5.75	30373	28875	27386	25898	24327	22531	20509	13637	64	314
1HDE48	7 1/2	1400	15393	8.63	34797	33489	32185	30890	29587	28228	26732	23270	82	337
	2	546	6861	2.23	25491	22893	19643	15016	7438	—	—	—	25	336
	3	654	8218	3.44	30533	28484	25851	23184	19758	10062	—	—	34	363
	5	776	9751	5.74	36229	34547	32578	30230	28002	25587	21690	—	46	354
	7 1/2	888	11159	8.62	41458	40004	38408	36530	34445	32495	30532	24084	55	377
1HDE54	10	978	12290	11.51	45660	44346	42949	41361	39557	37662	35903	32115	65	430
	3	543	7676	3.06	34004	30831	27100	21949	11218	—	—	—	35	413
	5	625	8835	4.57	39139	36422	33416	29868	25113	14175	10703	—	43	404
	7 1/2	772	10914	8.61	48344	46165	43888	41409	38656	35493	31517	—	62	427
	10	850	12016	11.50	53229	51253	49219	47060	44723	42157	39269	30729	74	480
1HDE60	15	973	13755	17.25	60931	59209	57458	55645	53723	51705	49532	44574	94	643
	5	550	8639	5.05	44408	40673	36244	30033	18243	13335	—	—	43	451
	7 1/2	681	10697	8.54	54985	52011	48831	45147	40633	34185	23302	—	65	474
	10	750	11781	11.54	60556	57865	55054	51942	48354	44045	38152	22558	85	527
1HDE60	15	859	13493	17.78	69537	67016	64615	62079	59306	56207	52608	42818	98	690
	20	945	14844	23.00	76300	74177	72013	69776	67395	64816	61991	55259	110	715

Performance certified is for installation type A: Free Inlet, Free Outlet. # Power rating (BHP) does not include transmission losses. Performance ratings do not include the effects of appurtenances (accessories). † The sound ratings are loudness in fan sones at 5 ft. (1.5m) in a hemispherical free field calculated per AMCA Standard 301. Values shown are for Installation Type A, Free Inlet, hemispherical sone levels.

Typical Specifications:

Heavy Duty Belt-Drive Exhaust Fans

Heavy duty belt-drive exhaust fans shall be axial belt-drive type. The propeller shall be constructed of steel. Propellers shall be statically balanced. The fan housing shall be constructed of steel with a rigid steel support structure and coated with a durable, baked-on polyester powder coat finish. Motors shall be readily accessible for maintenance. Steel shafts shall be turned, ground-polished and mounted in regreaseable, pillow block ball bearings. Bearings shall be selected for a minimum life (L50) in excess of 200,000 hours at maximum cataloged operating speed. Drives shall be sized for a minimum of 150% of driven horsepower. Pulleys shall be fully machined cast iron type, keyed and securely attached to the fan and motor shafts. All fans shall bear the AMCA Certified Ratings Seal for sound and air performance. Each fan shall bear a permanently affixed manufacturer's nameplate containing model number and carry a one-year warranty. Fans shall be Fantech Model Heavy Duty Belt-Drive Exhaust Fans as manufactured by Systemair Mfg. Inc., Lenexa, Kansas.

Wall Fan Accessories

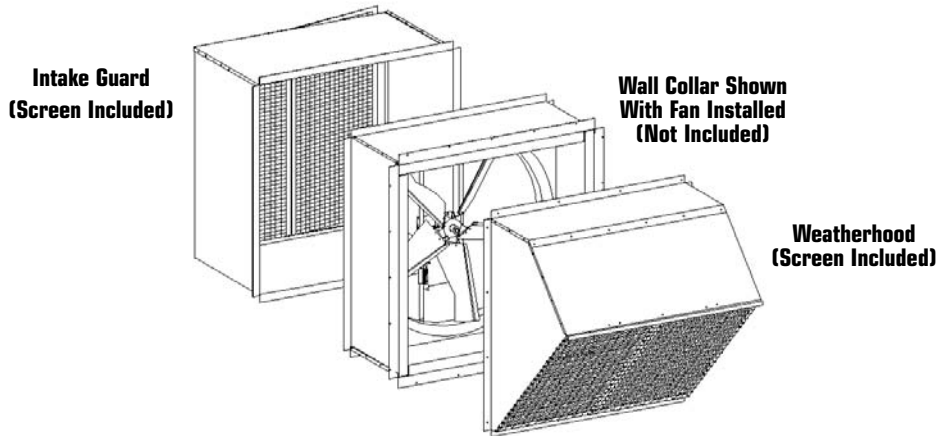

Intake Guards

- Intake guards comply with OSHA regulations
- Screens are hinged and removable for easy access
- 20-gauge galvanized steel construction

- For direct- and belt-drive propeller fans
- Shipped knocked down with assembly hardware included

WARNING: OSHA-compliant guards are required when fan is installed within 8.2 ft. (2.5M) of floor, working level or within reach of personnel. Review OSHA codes.

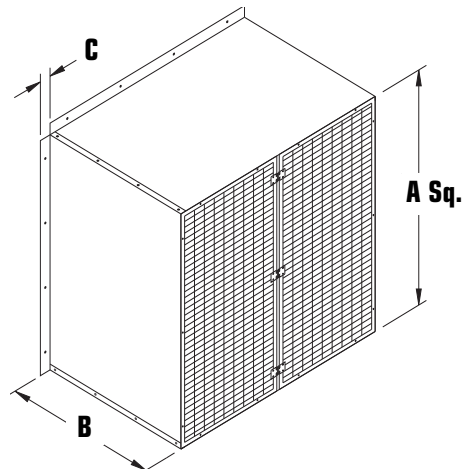

Model No.	Prop. Dia. (In.)	Dimensions (In.)			Grid Guard Sections	Side Panel Gauge	Ship Wt. (lbs.) (less motor pulleys & belts)
		A	B	C			
1ACC12SG	12	16-1/8	13	1-1/4	1	20	13
1ACC16SG	16	21-1/8	13	1-1/4	1	20	15
1ACC18SG	18	22-1/8	13	1-1/4	1	20	17
1ACC20SG	20	24-1/8	14	1-1/4	1	20	19
1ACC24SG	24	28-1/8	20	1-1/4	1	20	35
1ACC30SG	30	34-1/8	20	1-1/4	1	20	39
1ACC36SG	36	40-1/8	27	2	2	20	61
1ACC42SG	42	46-1/8	30	2	2	20	61
1ACC48SG	48	54-1/4	32	2	2	18	120
1ACC54SG	54	60-1/4	34	2	2	18	155
1ACC60SG	60	66-1/4	37	2	2	18	167

Wall Fan Accessories

Wall Collar

An easy way to install vertically mounted supply and exhaust fans. An internal flange is provided for shutter mounting. The external flange provides a flashing for the wall opening.

For direct- and belt-drive propeller fans. Galvanized steel construction. The wall collar is shipped unassembled with assembly hardware included.

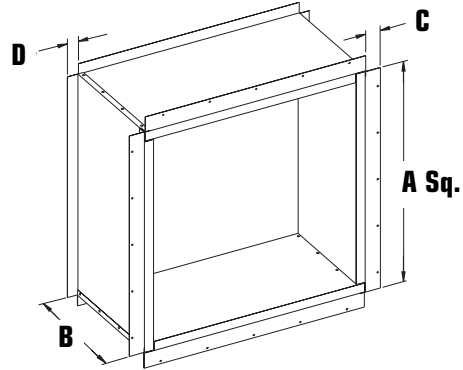

Weatherhood

Shield fan and damper openings in walls from rain and snow. For direct- and belt-drive propeller fans. Sized to easily mount to wall collar.

Galvanized steel construction. A bird screen is included. Weatherhoods are shipped unassembled with assembly hardware included.

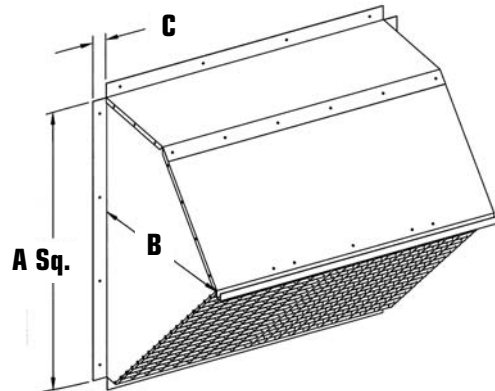
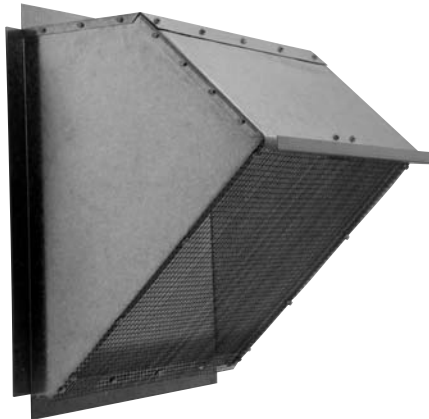

Model No.	Prop. Dia. (In.)	A	Dimensions (In.)			Gauge	Ship Wt. (lbs.)
			B	C	D		
WALL COLLARS							
1ACC24WC	24	28-1/8	18-1/2	2-3/4	2	16	53
1ACC30WC	36	34-1/8	19-1/2	2-3/4	2	16	77
1ACC36WC	36	40-1/8	21-1/2	2-3/4	2	16	88
1ACC42WC	42	46-1/8	21-1/2	2-3/4	2	16	97
1ACC48WC	48	54-1/8	23-1/2	2-3/4	2	16	123
HEAVY-DUTY WALL COLLARS							
1ACC48HC	48	54-1/8	23-1/2	2-3/4	2	14	165
1ACC54HC	54	60-3/8	23-1/2	2-3/4	2	14	185
1ACC60HC	60	66-3/8	23-1/2	2-3/4	2	14	200
WEATHERHOODS							
1ACC24WH	24	28-1/2	21	2	—	18	33
1ACC30WH	30	34-1/8	25	2	—	18	44
1ACC36WH	36	40-1/4	29	2	—	18	62
1ACC42WH	42	40-1/4	33	2	—	18	78
1ACC48WH	48	54-1/4	38	2	—	18	103
1ACC54WH	54	60-1/4	44-1/2	2	—	18	180
1ACC60WH	60	66-1/4	48-3/8	2	—	18	205

Wall Fan Accessories

Wall Dampers

For direct-drive and belt-drive prop axial wall ventilators. Blades open when ventilator comes on, close when airflow stops.



- Galvanized 19-gauge steel frame
- Aluminum blades have felt edges for quiet operation
- Frame is 3" deep with 1-5/8" flange
- Pre-punched conduit hole knock-out
- Optional damper motors available

Model No.	Damper Size (In.)	Outside Flange Dimension (In.)	For Use With These Ventilators (UL 705 Only)	Recommended Wall Opening (In.)	Optional Damper Motor
1ACC12WD	12-1/2 x 12-1/2	15 x 15	2VLD12, 2VHD12, 2DRV12, 2STV12, 2CAV12	13 X 13	1ACC01DM
1ACC16WD	16-1/2 x 16-1/2	19 x 19	2VLD16, 2VHD16, 2DRV16, 2STV16, 2CAV16	17 X 17	1ACC01DM
1ACC18WD	18-1/2 x 18-1/2	21 x 21	2VLD18, 2VHD18, 2DRV18, 2STV18, 2CAV18	19 X 19	1ACC01DM
1ACC20WD	20-1/2 x 20-1/2	23 x 23	2VLD20, 2VHD20, 2DRV20, 2STV20, 2CAV20	21 X 21	1ACC01DM
1ACC24WD	24-1/2 x 24-1/2	27 x 27	1SDE24, 1MDE24, 1HDE24, 2VLD24, 2VHD24, 2DRV24, 2STV24, 2CAV24	25 x 25	1ACC01DM
1ACC30WD	30-1/2 x 30-1/2	33 x 33	1SDE30, 1MDE30, 1HDE30, 2STV30	31 x 31	1ACC01DM
1ACC36WD	36-1/2 x 36-1/2	39 x 39	1SDE36, 1MDE36, 1HDE36	37 x 37	1ACC01DM
1ACC42WD	42-1/2 x 42-1/2	45 x 45	1SDE42, 1MDE42, 1HDE42	43 x 43	1ACC02DM
1ACC48WD	48-1/2 x 48-1/2	51 x 51	1SDE48, 1MDE48, 1HDE48	49 x 49	1ACC02DM
1ACC54WD	54-1/2 x 54-1/2	57 x 57	1MDE54, 1HDE54	55 x 55	1ACC03DM
1ACC60WD	60-1/2 x 60-1/2	63 x 63	1MDE60, 1HDE60	61 x 61	1ACC03DM

Motorized Dampers

- Galvanized 14-gauge steel frame, 16-gauge steel blades
- Frame is 2" deep with 1-1/2" flange
- Power on to open, spring return to close
- 120/240V, 0.19/0.11 amps, 60 Hz (54" and 60" models 240V only)
- 3500 FPM max.



Model No.	Damper Size (In.)	Outside Flange Dimension (In.)	Ship Wt. (lbs.)	For Use With These Ventilators (UL 705 Only)	Recommended Wall Opening (In.)
1ACC24MD	24 x 24	27 x 27	32	1SDE24, 1SDS24, 1MDE24, 1HDE24	25 x 25
1ACC30MD	30 x 30	33 x 33	42	1SDE30, 1SDS30, 1MDE30, 1HDE30	31 x 31
1ACC36MD	36 x 36	39 x 39	70	1SDR36, 1SDE36, 1SDS36, 1MDE36, 1HDE36	37 x 37
1ACC42MD	42 x 42	45 x 45	74	1SDE42, 1SDS42, 1MDE42, 1HDE42	43 x 43
1ACC48MD	48 x 48	51 x 51	91	1SDE48, 1SDS48, 1MDE48, 1HDE48	49 x 49
1ACC54MD	54 x 54	57 x 57	115	1MDE54, 1HDE54	55 x 55
1ACC60MD	60 x 60	63 x 63	170	1MDE60, 1HDE60	61 x 61

Intake Louvers – Models FLV and MLV

Model FLV – Fixed Blade Louver

(shown with optional flange)

Extruded Aluminum Stationary

Non-Drainable Louvers

Model FLV louvers are designed to combine outstanding performance with improved aesthetic appearance.

- Blade Angle: 45 Degrees
 - Frame Depth: 4 inches
 - Frame Type: Channel
 - Frame Thickness: 0.081 inches
- Contact Factory for Optional Features
Add 10% for Angle (flanged) frames.

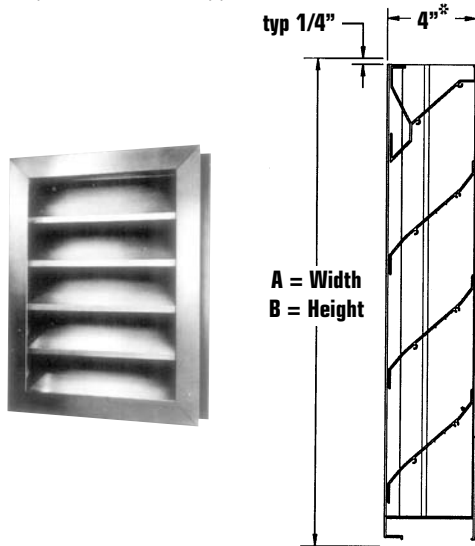

Section View

Standard Specifications

- Frame: 4" deep channel, .081" thick 6063-T5 Extruded Aluminum Alloy
 - Blades: .081" thick 6063-T5 extruded aluminum alloy
 - Finish: Mill
 - Screen: 1/2" removable expanded aluminum bird screen, located on interior
 - Maximum Panel Size: 96" x 96"
 - Minimum Panel Size: 12" x 12"
 - Dimensions: "A" (width) "B" (height) are opening sizes. Louvers are made 1/2" undersize
- * Panels over 60" wide will be 5-1/2" deep due to a vertical interior blade support angle.

Model MLV – Adjustable Blade

(shown with optional motor & flange)

Extruded Aluminum Adjustable

Non-Drainable Louvers

Model MLV louvers are available with motorized operators. Multiple panels are joined by a substantial jackshaft assembly which is driven by one or more actuators. Contact factory for details.

- Blade Angle: Adjustable
 - Frame Depth: 4 inches
 - Frame Type: Channel
 - Frame Thickness: 0.081 inches
- Contact Factory for Optional Features
Add 10% for Angle (flanged) frames.

Actuators		
Model	Control	Stock No
MA405	120V	45401

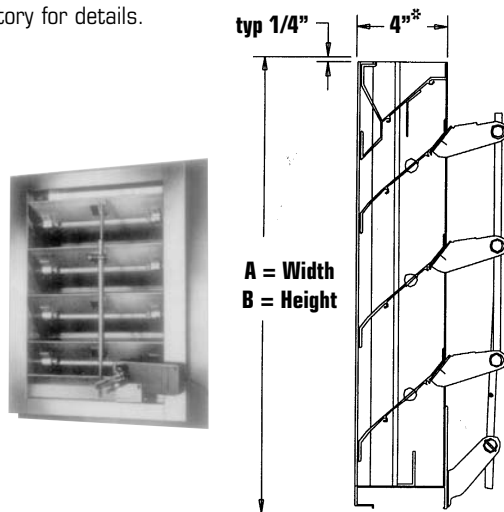

Section View

Standard Specifications

- Frame: 4" deep channel, .081" thick 6063-T5 Extruded Aluminum Alloy
- Blades: .081" thick 6063-T5 extruded aluminum alloy
- Finish: Mill
- Screen: 1/2" removable expanded aluminum bird screen, located on exterior
- Axles: 1/2" diameter aluminum
- Bearings: Polymer plastic split
- Linkage: Plated steel brackets, brass barrels, 5/16" dia. Plated steel linkage rod
- Actuator: Individual panel wing nut. See actuator bulletin for other selections.
- Maximum Panel Size: 60" x 96" w/o seals or w/blade seals only
48" x 72" with blade and jamb seals
- Minimum Panel Size: 12" x 12"
- Dimensions: "A" (width) "B" (height) are opening sizes. Louvers are made 1/2" undersize

Louver models available from stock are listed below. Contact factory regarding delivery for all other models.	
FLV3636	36" x 36" Fixed Louver
FLV4860	48" x 60" Fixed Louver
MLV3636	36" x 36" Motorized Louver
MLV4860	48" x 60" Motorized Louver

Intake Louvers – Models FLV and MLV

Water Penetration: 0.01 oz. at 677 fpm recommended free area velocity

Pressure Drop: 0.10 in. WG at 677 fpm and 5518 SCFM

Free Area: 8.15 square feet = 51% for 48" x 48" test size

Both maximum recommended free area velocity and the beginning of water penetration are 677 fpm at standard air - 0.075lbs. per ft³. The above water penetration data is based on mill finish, 48" x 48" test size per AMCA Standard 511, effective November, 1990.

Model FLV - Free Area, ft ²									
		WIDTH							
		12"	24"	36"	48"	60"	72"	84"	96"
HEIGHT	12"	0.26	0.61	0.96	1.31	1.62	1.97	2.32	2.67
	24"	0.73	1.72	2.72	3.71	4.58	5.58	6.58	7.57
	36"	1.12	2.66	4.21	5.75	7.09	8.64	10.18	11.72
	48"	1.59	3.78	5.96	8.15	10.06	12.25	14.43	16.62
	60"	2.01	4.78	7.54	10.30	12.72	15.48	18.24	21.01
	72"	2.46	5.84	9.22	12.60	15.56	18.94	22.32	25.70
	84"	2.93	6.96	10.98	15.01	18.53	22.56	26.58	30.61
	96"	3.33	7.90	12.47	17.04	21.04	25.61	30.18	34.75

Model MLV - Free Area, ft ²						
		WIDTH				
		12"	24"	36"	48"	60"
HEIGHT	12"	0.18	0.42	0.67	1.91	1.15
	24"	0.56	1.32	2.09	2.85	2.62
	36"	0.91	2.17	3.42	4.68	5.93
	48"	1.40	3.31	5.23	7.15	9.06
	60"	1.83	4.33	6.84	9.34	11.85
	72"	2.19	5.20	8.20	11.21	14.21
	84"	2.62	6.20	9.79	13.38	16.97
	96"	3.09	7.32	11.56	15.79	20.02

To determine the proper size FLV or MLV louver, follow the procedure given below.

1. Divide the required cfm by the maximum recommended free area velocity of 677 fpm.
2. Reference the appropriate free area table shown above and select the size louver that meets the minimum free area requirement.

Example:

Step #1.

$$\text{Minimum Free Area} = \frac{\text{Design CFM}}{\text{Max. Recommended Velocity}}$$

$$= \frac{5,000}{677} = 7.39 \text{ ft}^2$$

Step #2.

From the free area tables, the appropriate selections are:

- FLV3660 36" x 60" Fixed Louver
- MLV4848 48" x 48" Motorized Louver

Openings that require multiple louver panels in both width and height will require internal structural supports. It is recommended that large openings be divided with structural members so that the louvers will span either width or height with a single panel. Unusually high wind loading may require structural supports on non-multiple wide and multiple high assemblies.

Structural supports and mounting accessories are not supplied as standard by Fantech.

Gravity-Relief/Intake Ventilators

MODEL TIV/TEV

Low Silhouette Design

Birdscreen Standard

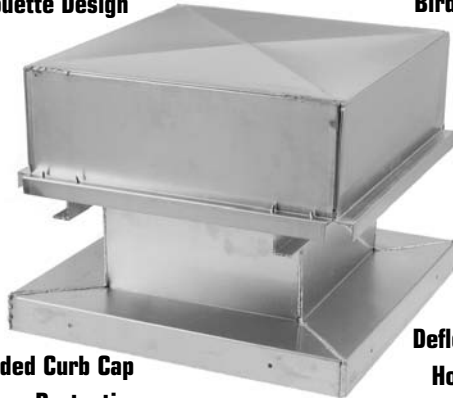

Fully Welded Curb Cap For Weather Protection

Deflector Flange On Hood For Added Weather Protection

Description

Model TIV/TEV Hooded Gravity Intake & Relief ventilators offer a low silhouette that blends with modern roof lines and other equipment. With a full 360 degree perimeter hood opening for a more reliable air flow. Exhaust models have a 1:1 ratio of hood perimeter to throat area and Intake models have a 2:1 ratio for low resistance and more efficient air flow.

Options/Accessories

Hinged Hood: Offers easy access to back draft dampers, and for servicing filters and screens.

Aluminum Bird Screen: .050" thick x .5" x 1" diamond shaped expanded aluminum attached to the full perimeter of hood opening by spot welds or stainless steel fasteners.

Insect Screen: 18 mesh aluminum screen attached to full perimeter of hood opening. Add .10" to static pressure for TEV and .05" to static pressure for TIV.

Insulated Hood: Reduces condensate drip. Rubberized anti-condensate, or 1" fiberglass insulation.

Filters: 1" or 2" thick permanent aluminum mesh mounted for easy cleaning. Add .13" to static pressure in the listed tables when using filters with TIV.

Protective Coatings:

- **Epoxy:** A tough gray coating that is one of the best heavy-duty multi purpose finishes, resistant to most chemicals and corrosives.
- **Eisenheiss:** A synthetic resin that forms a tough coating offering better protection against most acids and corrosive agents.
- **Heresite:** A black phenolic coating that has good resistance to heat, solvents and concentrates of most acids except strong oxidizing agents. Resistant to weak alkalis but not recommended for hydrofluoric acid or hypochlorite salts.

Decorative Coatings: A variety of industrial grade enamels. (Paint chip required).

Galvanized Steel Construction:

100 MPH Construction: Extra heavy internal reinforcement and bracing.

Special Sizes & Options: Consult the factory for sizes and options not listed

Construction Features

- **Base:** Constructed of .080" Aluminum.
- **Hood:** Constructed of .050" Aluminum. Reinforced and braced for extra rigidity and resistance to wind damage. Hoods have a special deflector flange on the edge of the perimeter for added protection against rain and snow.
- **Bird Screen:** 1/2" x 1/2" galvanized wire mesh, (omitted when filters fitted). Screens are attached to full perimeter opening with stainless or zinc plated fasteners.
- **Curb Base:** Constructed of .050" Aluminum. All corners miter cut. All seams are continuously welded for strength and water tightness.
- **Perimeter:** Hood opening full 360 degrees for more reliable air flow.

Optional Features

- Hood only of 080 Aluminum (Add 20% for weight)
- Hood only of 063 Aluminum (Add 10% for weight)
- Galvanized Steel - hoods equal to or smaller than 36x36 throat
- Galvanized Steel - hoods larger than 36x36 throat
- Hinged Hood
- Additional Throat Height*- each additional 1" (Add 5% for weight)
- 100 MPH rating
- Change Base Dimensions
- Splitters for individual ducts
- Damper shelf in throat. (requires hinged hood also)
- 1/2" Foam Rubber Gasket on underside of base
- Aluminum Insect Screen
- Aluminum Bird Screen
- Snow Screen (Bird Screen over Insect Screen)
- 1" Aluminum Filters (Add 5% for weight)
- 2" Aluminium Filters (Add 10% for weight)
- Filter Rack only 1" Filters
- Filter Rack only 2" Filters
- Mastic Anticondensate - Top of hood only
- 1" Fiberglass insulation (Top of hood only-add for weight)
- Paint setup charge per order, per color
- Decorative Enamel on exterior only
- Primer coating on exterior only
- Epoxy coating (Gray) inside & Outside
- Eisenheiss or Heresite Finish
- Epoxy Coating on Bird Screen Only 1

*Standard Throat Height is 5". Maximum Throat Height is 36"

TIV Performance Data - Intake Supply

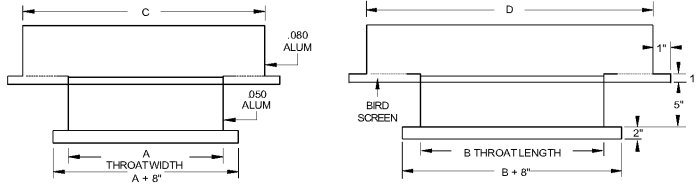

Throat Size A X B	Width C	Length D	Height E	CFM@Static Pressure		
				0.05	0.1	0.2
12						
12 x 12	21	21	7	685	969	1307
12 x 14	22	24	7	801	1133	1602
12 x 16	22	26	7	912	1289	1824
12 x 18	23	29	7	1058	1496	2115
12 x 20	24	32	7	1177	1664	2354
12 x 22	24	34	7	1254	1774	2509
12 x 24	25	37	7	1402	1983	2804
12 x 28	26	42	7	1634	2311	3268
12 x 30	26	44	7	1790	2531	3579
12 x 36	27	51	7	2124	3004	4248
12 x 40	28	56	7	2282	3227	4564
12 x 42	29	59	7	2435	3444	4870
12 x 48	28	64	7	2783	3935	5566
12 x 54	28	70	7	3120	4413	6240
12 x 60	29	77	7	3468	4904	6936
12 x 66	29	83	7	3811	5389	7621
12 x 72	30	90	7	4158	5881	8317
12 x 80	30	98	7	4601	6507	9202
12 x 84	31	103	7	4844	6850	9687
12 x 96	31	115	7	5523	7811	11047
12 x 108	31	127	8	6399	9050	12799
12 x 120	32	140	8	6931	9801	13861
14						
14 x 14	25	25	8	933	1319	1866
14 x 16	25	27	8	1095	1549	2191
14 x 18	26	30	8	1196	1692	2393
14 x 20	27	33	8	1333	1886	2667
14 x 22	28	36	8	1508	2132	3015
14 x 25	28	38	8	1550	2192	3100
14 x 28	29	43	8	1897	2683	3795
14 x 30	29	45	8	1998	2825	3995
14 x 36	30	52	8	2129	3011	4259
14 x 40	30	56	8	2667	3772	5334
14 x 42	30	59	8	2830	4003	5660
14 x 48	31	66	8	3330	4709	6660
14 x 54	32	72	8	3637	5143	7273
14 x 60	33	79	8	4032	5702	8064
14 x 66	33	85	8	4427	6261	8854
14 x 72	34	92	8	4849	6857	9698
14 x 80	34	100	8	5227	7393	10455
14 x 84	35	105	8	5597	7916	11194
14 x 96	35	117	8	6393	9041	12786
14 x 108	36	130	9	7221	10211	14441
14 x 120	36	142	9	8249	11666	16498
16						
16 x 16	28	28	9	1217	1722	2435
16 x 18	28	30	9	1370	1938	2741
16 x 20	29	33	9	1567	2217	3135
16 x 22	30	36	9	1725	2439	3449
16 x 24	31	39	9	1790	2531	3580
16 x 28	32	44	9	2070	2927	4140
16 x 30	32	46	9	2287	3235	4575
16 x 36	33	53	9	2814	3980	5629
16 x 40	33	57	9	3046	4308	6093
16 x 42	33	60	9	3236	4576	6472
16 x 48	35	67	9	3684	5210	7368
16 x 54	36	74	9	3945	5579	7890
16 x 60	36	80	9	4390	6208	8780
16 x 66	37	87	9	5065	7163	10130
16 x 72	38	94	9	5545	7841	11089
16 x 80	38	102	9	5976	8452	11953
16 x 84	39	107	9	6393	9041	12786
16 x 96	39	119	9	7336	10375	14673
16 x 108	40	132	10	8054	11390	16108
16 x 120	40	144	10	9171	12969	18341

Throat Size A X B	Width C	Length D	Height E	CFM@Static Pressure		
				0.05	0.1	0.2
18						
18 x 18	32	32	10	1539	2176	3078
18 x 20	33	35	10	1763	2493	3525
18 x 22	33	37	10	1882	2661	3763
18 x 24	34	40	10	2000	2828	4000
18 x 28	35	45	10	2330	3295	4660
18 x 30	36	48	10	2567	3630	5133
18 x 36	37	55	10	3104	4390	6209
18 x 40	38	60	10	3426	4845	6852
18 x 42	38	62	10	3637	5143	7273
18 x 48	39	69	10	3950	5586	7900
18 x 54	40	76	10	4440	6279	8880
18 x 60	40	82	10	4811	6804	9622
18 x 66	41	89	10	5718	8087	11437
18 x 72	41	95	10	6074	8590	12148
18 x 80	42	104	10	6720	9504	13440
18 x 84	43	109	10	7084	10019	14169
18 x 96	43	121	10	8003	11317	16005
18 x 108	44	134	11	9250	13081	18499
18 x 120	45	147	11	10277	14534	20555
20						
20 x 20	35	35	11	1942	2761	3905
20 x 22	36	38	11	2092	2959	4185
20 x 24	37	41	11	2220	3140	4440
20 x 28	37	45	11	2730	3861	5460
20 x 30	38	48	11	2857	4040	5713
20 x 36	40	56	11	3484	4927	6968
20 x 40	40	60	11	3704	5238	7408
20 x 42	41	63	11	3835	5424	7670
20 x 48	42	70	11	4260	6024	8520
20 x 54	43	77	11	4930	6972	9860
20 x 60	44	84	11	5348	7563	10696
20 x 66	45	91	11	6025	8521	12050
20 x 72	45	97	11	6720	9504	13440
20 x 80	46	106	11	7669	10845	15337
20 x 84	46	110	11	7838	11085	15677
20 x 96	47	123	11	9171	12969	18341
20 x 108	48	136	11	10034	14190	20068
20 x 120	49	149	11	11463	16211	22927
22						
22 x 22	39	39	11	2303	3257	4606
22 x 24	40	42	11	2440	3451	4880
22 x 28	40	46	11	2978	4211	5956
22 x 30	42	50	11	3141	4442	6282
22 x 36	43	57	11	3640	5148	7280
22 x 40	44	62	11	4078	5768	8157
22 x 42	45	65	11	4220	5968	8440
22 x 48	46	72	11	4805	6795	9610
22 x 54	46	78	11	5275	7460	10549
22 x 60	47	85	11	6025	8521	12050
22 x 66	48	92	11	6446	9116	12892
22 x 72	49	99	11	7200	10182	14400
22 x 80	50	108	11	8000	11314	16000
22 x 84	50	112	11	8623	12195	17247
22 x 96	51	125	11	10067	14236	20133
22 x 108	52	138	11	11004	15561	22007
22 x 120	53	151	11	12607	17829	25214
24						
24 x 24	42	42	11	2650	3748	5300
24 x 28	43	47	11	3262	4614	6525
24 x 30	44	50	11	3457	4890	6915
24 x 36	46	58	11	3945	5579	7890
24 x 40	47	63	11	4335	6131	8670
24 x 42	48	66	11	4600	6505	9200
24 x 48	49	73	11	5275	7460	10550
24 x 54	50	80	11	5915	8365	11830
24 x 60	52	88	11	6580	9306	13160
24 x 66	52	94	11	7205	10189	14410
24 x 72	52	100	11	7855	11109	15710
24 x 80	53	109	11	8700	12304	17400
24 x 84	54	114	11	8949	12656	17898
24 x 96	55	127	11	10400	14708	20800
24 x 108	56	140	11	11750	16617	23500
24 x 120	57	154	11	13440	19007	26881

TIV Performance Data - Intake Supply

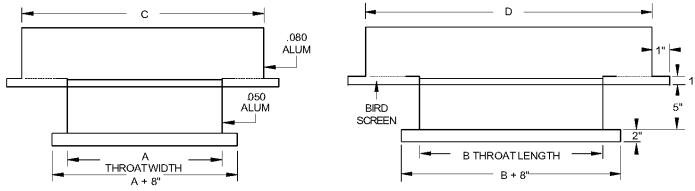

Throat Size A X B	Width C	Length D	Height E	CFM@Static Pressure		
				0.05	0.1	0.2
28						
28 x 28	51	51	13	3789	5359	7579
28 x 30	51	53	13	4058	5739	8117
28 x 36	52	60	13	4600	6505	9200
28 x 40	53	65	13	5055	7149	10110
28 x 42	53	67	13	5370	7594	10740
28 x 48	54	74	13	6065	8577	12130
28 x 54	56	82	13	6900	9758	13800
28 x 60	57	89	13	7650	10819	15300
28 x 66	58	96	13	8189	11593	16395
28 x 72	59	103	13	9135	12919	18270
28 x 80	60	112	13	9630	13619	19260
28 x 84	61	117	13	10655	15068	21310
28 x 96	63	131	13	12150	17183	24300
28 x 108	64	144	13	13650	19304	27300
28 x 120	65	157	13	16049	22696	32097
30						
30 x 30	53	53	13	4207	5949	8413
30 x 36	55	61	13	4792	6776	9583
30 x 40	55	65	13	5455	7715	10910
30 x 42	57	69	13	5616	7943	11233
30 x 48	57	76	13	6343	8971	12687
30 x 54	60	84	13	7350	10394	14700
30 x 60	61	91	13	8175	11561	16350
30 x 66	62	98	13	8788	12428	17576
30 x 72	63	105	13	9840	13916	19680
30 x 80	64	114	13	10613	15009	21226
30 x 84	65	119	13	11420	16150	22840
30 x 96	66	132	13	13050	18455	26100
30 x 108	67	145	13	14550	20577	29100
30 x 120	69	159	13	16570	23433	33139
36						
36 x 36	63	63	15	5425	7672	10850
36 x 40	64	68	15	6392	9040	12784
36 x 42	66	72	15	6900	9758	13800
36 x 48	67	79	15	7437	10518	14874
36 x 54	69	87	15	8750	12374	17500
36 x 60	70	94	15	9875	13965	19750
36 x 66	71	101	15	10805	15281	21610
36 x 72	72	108	15	11750	16617	23500
36 x 80	74	117	15	12443	17597	24885
36 x 84	75	123	15	12775	18067	25551
36 x 96	77	137	15	14874	21035	29748
36 x 108	78	150	15	16690	23604	33381
36 x 120	79	165	15	19400	27436	38800
40						
40 x 40	70	70	17	7051	9971	14102
40 x 42	71	73	17	7640	10805	15280
40 x 48	73	81	17	8267	11691	16533
40 x 54	74	88	17	9588	13560	19176
40 x 60	76	96	17	10407	14718	20814
40 x 66	77	103	17	11451	16194	22902
40 x 72	79	111	17	12687	17942	25373
40 x 80	81	121	17	13773	19478	27546
40 x 84	83	127	17	14459	20448	28919
40 x 96	83	139	17	16524	23368	33047
40 x 108	85	153	17	18593	26294	37185
40 x 120	87	167	17	21585	30526	43170

Throat Size A X B	Width C	Length D	Height E	CFM@Static Pressure		
				0.05	0.1	0.2
42						
42 x 42	74	74	18	7832	11076	15663
42 x 48	76	82	18	8229	11637	16457
42 x 54	78	90	18	9835	13909	19670
42 x 60	80	98	18	10965	15507	21930
42 x 66	82	106	18	12023	17003	24046
42 x 72	83	113	18	13209	18680	26418
42 x 80	84	122	18	13844	19578	27687
42 x 84	84	126	18	14537	20559	29075
42 x 96	87	141	18	16972	24001	33943
42 x 108	89	155	18	19451	27507	38901
42 x 120	91	169	18	21605	30555	43211
48						
48 x 48	84	84	20	9347	13218	18694
48 x 54	87	93	20	10545	14913	21091
48 x 60	88	100	20	11717	16570	23434
48 x 66	89	107	20	13386	18931	26772
48 x 72	92	116	20	13908	19669	27817
48 x 80	94	126	20	15505	21927	31010
48 x 84	95	131	20	16614	23496	33229
48 x 96	96	144	20	19321	27325	38643
48 x 108	95	165	20	21279	30093	42558
48 x 120	97	178	20	23735	33566	47469
54						
54 x 54	95	95	23	11865	16779	23729
54 x 60	97	103	23	13197	18664	26395
54 x 66	98	110	23	14391	20352	28783
54 x 72	98	121	23	15697	22199	31394
54 x 80	98	133	23	17397	24603	34793
54 x 84	98	140	23	18833	26633	37665
54 x 96	98	160	23	21737	30740	43473
54 x 108	98	179	23	23456	33172	46913
54 x 120	111	177	23	25858	36569	51716
60						
60 x 60	95	115	25	14534	20555	29069
60 x 66	96	124	25	16001	22629	32003
60 x 72	109	121	25	17397	24603	34793
60 x 80	111	131	25	19306	27303	38612
60 x 84	113	137	25	20268	28663	40535
60 x 96	115	151	25	23166	32761	46331
60 x 108	118	166	25	25961	36714	51921
60 x 120	118	184	25	28175	39846	56351
66						
66 x 66	98	134	25	17468	24704	34936
66 x 72	117	123	25	18681	26419	37363
66 x 80	117	135	25	21234	30029	42467
66 x 84	117	142	25	22298	31534	44596
66 x 96	117	162	25	25482	36037	50964
66 x 108	127	169	25	27890	39443	55781
66 x 120	130	184	25	30872	43660	61745
72						
72 x 72	117	137	25	20370	28807	40739
72 x 80	128	135	28	22716	32125	45432
72 x 84	130	142	29	24324	34399	48648
72 x 96	133	157	29	27259	38550	54518
72 x 108	136	172	29	30311	42866	60622
72 x 120	139	187	29	33679	47629	67358

TEV Performance Data - Exhaust Relief

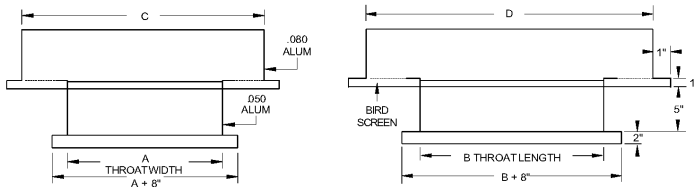

Throat Size A X B	Width C	Length D	Height E	CFM@Static Pressure		
				0.05	0.1	0.2
12						
12 x 12	18	18	7	667	1054	1490
12 x 14	18	20	7	772	1220	1726
12 x 16	18	22	7	881	1394	1971
12 x 18	19	25	7	993	1570	2221
12 x 20	19	27	7	1059	1675	2368
12 x 22	19	29	7	1185	1874	2650
12 x 24	20	32	7	1252	1980	2800
12 x 28	20	36	7	1462	2312	3270
12 x 30	20	38	7	1565	2475	3500
12 x 36	21	45	7	1775	2807	3970
12 x 40	21	48	7	1954	3090	4370
12 x 42	22	52	7	2048	3239	4580
12 x 48	21	57	7	2392	3782	5348
12 x 54	22	64	7	2567	4059	5741
12 x 60	22	70	7	2798	4423	6255
12 x 66	22	76	7	2998	4740	6704
12 x 72	22	82	7	3204	5066	7165
12 x 80	22	90	7	3437	5434	7685
12 x 84	22	94	7	3719	5879	8315
12 x 96	22	106	7	4119	6513	9210
12 x 108	22	120	7	4448	7033	9946
12 x 120	22	132	7	4896	7741	10947
14						
14 x 14	20	20	7	919	1453	2055
14 x 16	20	22	7	1051	1662	2350
14 x 18	22	26	7	1181	1867	2640
14 x 20	22	28	7	1237	1955	2765
14 x 22	22	30	7	1386	2192	3100
14 x 24	22	32	7	1425	2253	3187
14 x 28	22	36	7	1671	2642	3736
14 x 30	23	39	7	1825	2885	4080
14 x 36	23	45	7	2075	3281	4640
14 x 40	23	49	7	2323	3673	5195
14 x 42	24	52	7	2393	3783	5350
14 x 48	24	58	7	2789	4410	6236
14 x 54	24	64	7	3059	4836	6839
14 x 60	24	70	7	3264	5160	7298
14 x 66	24	77	7	3502	5536	7830
14 x 72	24	84	7	3738	5911	8359
14 x 80	25	92	7	4012	6344	8971
14 x 84	25	95	7	4243	6709	9487
14 x 96	26	108	7	4805	7598	10745
14 x 108	26	120	7	5189	8205	11604
14 x 120	26	132	7	5712	9031	12772
16						
16 x 16	23	23	7	1199	1895	2680
16 x 18	24	26	7	1342	2121	3000
16 x 20	24	28	7	1470	2324	3286
16 x 22	24	30	7	1616	2555	3613
16 x 24	25	33	7	1668	2638	3730
16 x 28	26	38	7	1950	3083	4360
16 x 30	26	40	7	2088	3302	4670
16 x 36	26	46	7	2370	3748	5300
16 x 40	26	50	7	2656	4200	5940
16 x 42	26	52	7	2789	4410	6236
16 x 48	27	59	7	3190	5045	7134
16 x 54	27	65	7	3354	5303	7500
16 x 60	27	71	7	3578	5657	8000
16 x 66	28	78	7	3763	5949	8413
16 x 72	28	84	7	4105	6490	9178
16 x 80	28	92	7	4387	6937	9810
16 x 84	28	96	7	4655	7361	10410
16 x 96	28	108	7	5152	8146	11520
16 x 108	29	121	7	5578	8820	12473
16 x 120	29	133	7	6261	9899	14000

Throat Size A X B	Width C	Length D	Height E	CFM@Static Pressure		
				0.05	0.1	0.2
18						
18 x 18	26	26	8	1543	2439	3450
18 x 20	27	29	8	1690	2672	3779
18 x 22	27	31	8	1856	2934	4149
18 x 24	27	33	8	1917	3031	4287
18 x 28	28	38	8	2191	3465	4900
18 x 30	28	40	8	2348	3712	5250
18 x 36	29	47	8	2614	4133	5844
18 x 40	29	51	8	2929	4632	6550
18 x 42	29	53	8	3077	4865	6880
18 x 48	30	60	8	3515	5558	7860
18 x 54	30	66	8	3852	6091	8614
18 x 60	30	72	8	4025	6364	9000
18 x 66	31	79	8	4232	6691	9463
18 x 72	31	85	8	4618	7301	10326
18 x 80	31	92	8	4955	7835	11081
18 x 84	31	97	8	5135	8119	11483
18 x 96	32	110	8	5577	8818	12471
18 x 108	32	122	8	6400	10119	14310
18 x 120	33	135	8	6907	10921	15444
20						
20 x 20	29	29	9	1802	2850	4030
20 x 22	29	31	9	1981	3132	4430
20 x 24	30	34	9	2177	3443	4869
20 x 28	31	39	9	2536	4010	5672
20 x 30	31	41	9	2661	4207	5950
20 x 36	31	47	9	2961	4681	6620
20 x 40	32	52	9	3256	5148	7280
20 x 42	32	54	9	3417	5402	7640
20 x 48	33	61	9	3985	6300	8910
20 x 54	33	67	9	4277	6762	9563
20 x 60	33	73	9	4472	7071	10000
20 x 66	34	80	9	4893	7736	10941
20 x 72	34	86	9	5340	8444	11941
20 x 80	34	94	9	5728	9057	12809
20 x 84	35	98	9	5818	9199	13010
20 x 96	35	111	9	6440	10182	14400
20 x 108	35	123	9	7413	11722	16577
20 x 120	36	136	9	8343	13191	18655
22						
22 x 22	32	32	9	2223	3515	4970
22 x 24	32	34	9	2342	3702	5236
22 x 28	33	39	9	2679	4236	5990
22 x 30	33	41	9	2871	4540	6420
22 x 36	34	48	9	3260	5155	7290
22 x 40	34	52	9	3508	5547	7845
22 x 42	36	56	9	3757	5940	8400
22 x 48	35	61	9	4214	6663	9423
22 x 54	36	68	9	4521	7149	10110
22 x 60	37	75	9	4919	7778	11000
22 x 66	37	81	9	5277	8344	11800
22 x 72	37	87	9	5756	9100	12870
22 x 80	38	96	9	6176	9765	13810
22 x 84	38	100	9	6532	10327	14605
22 x 96	38	112	9	7084	11201	15840
22 x 108	39	125	9	8155	12894	18235
22 x 120	39	137	9	8975	14191	20070

TEV Performance Data - Exhaust Relief

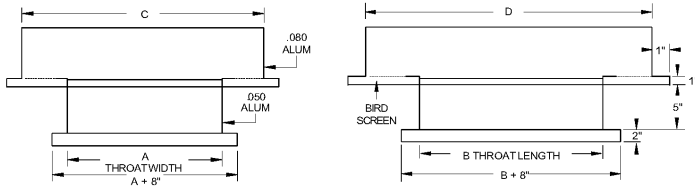

Throat Size A X B	Width C	Length D	Height E	CFM@Static Pressure		
				0.05	0.1	0.2
24						
24 x 24	34	34	11	2456	3883	5491
24 x 28	35	39	11	2864	4528	6403
24 x 30	36	42	11	3070	4854	6864
24 x 36	37	49	11	3486	5512	7796
24 x 40	38	54	11	3904	6173	8730
24 x 42	38	56	11	4101	6484	9170
24 x 48	38	62	11	4687	7410	10480
24 x 54	39	69	11	5031	7955	11250
24 x 60	39	75	11	5367	8485	12000
24 x 66	40	82	11	5756	9100	12870
24 x 72	40	88	11	6279	9928	14040
24 x 80	40	96	11	6878	10876	15381
24 x 84	40	100	11	6891	11038	15610
24 x 96	41	113	11	7887	12471	17636
24 x 108	42	126	11	8709	13770	19473
24 x 120	42	138	11	9197	15481	21894
28						
28 x 28	40	40	13	3478	5499	7777
28 x 30	41	43	13	3654	5777	8170
28 x 36	41	49	13	4146	6555	9270
28 x 40	43	55	13	4651	7354	10400
28 x 42	43	59	13	4785	7566	10700
28 x 48	43	63	13	5469	8648	12230
28 x 54	45	70	13	5867	9277	13120
28 x 60	44	76	13	6139	9707	13728
28 x 66	45	83	13	6582	10408	14719
28 x 72	45	89	13	7476	11821	16718
28 x 80	46	98	13	7862	12431	17580
28 x 84	46	102	13	8490	13425	18985
28 x 96	47	115	13	9202	14549	20576
28 x 108	48	128	13	10160	16065	22719
28 x 120	48	140	13	11423	18062	25543
30						
30 x 30	43	43	13	3893	6156	8706
30 x 36	44	50	13	4537	7174	10145
30 x 40	45	55	13	4884	7722	10920
30 x 42	45	57	13	5125	8103	11460
30 x 48	46	64	13	5745	9083	12846
30 x 54	47	71	13	6166	9749	13787
30 x 60	48	78	13	6708	10607	15000
30 x 66	48	84	13	7196	11377	16090
30 x 72	49	91	13	7696	12169	17209
30 x 80	49	99	13	8258	13056	18464
30 x 84	50	104	13	8725	13796	19510
30 x 96	50	116	13	9859	15588	22045
30 x 108	51	129	13	10886	17212	24342
30 x 120	52	142	13	12239	19352	27368
36						
36 x 36	52	52	15	5558	8788	12427
36 x 40	53	57	15	5979	9454	13370
36 x 42	53	59	15	6276	9923	14034
36 x 48	54	66	15	7175	11345	16044
36 x 54	55	73	15	7549	11936	16880
36 x 60	56	80	15	8050	12728	18000
36 x 66	56	86	15	8809	13929	19698
36 x 72	57	93	15	9613	15199	21494
36 x 80	58	102	15	10107	15981	22600
36 x 84	58	106	15	10469	16553	23410
36 x 96	59	119	15	11367	17972	25417
36 x 108	60	132	15	13063	20655	29210
36 x 120	60	144	15	14378	22733	32150

Throat Size A X B	Width C	Length D	Height E	CFM@Static Pressure		
				0.05	0.1	0.2
40						
40 x 40	57	57	15	6641	10501	14850
40 x 42	57	59	15	6974	11027	15595
40 x 48	59	67	15	7813	12353	17470
40 x 54	59	73	15	8385	13258	18750
40 x 60	60	80	15	8944	14142	20000
40 x 66	61	87	15	9593	15167	21450
40 x 72	62	94	15	10465	16546	23400
40 x 80	63	103	15	11230	17755	25110
40 x 84	64	108	15	11411	18042	25515
40 x 96	64	120	15	12880	20365	28800
40 x 108	65	133	15	14515	22950	32456
40 x 120	66	146	15	16319	25802	36490
42						
42 x 42	59	59	15	7178	11349	16050
42 x 48	61	67	15	8202	12968	18340
42 x 54	62	74	15	8806	13923	19690
42 x 60	64	82	15	9585	15155	21433
42 x 66	65	89	15	10071	15924	22520
42 x 72	65	95	15	10988	17374	24570
42 x 80	66	104	15	11793	18646	26370
42 x 84	66	108	15	12470	19717	27883
42 x 96	67	121	15	13803	21824	30864
42 x 108	68	134	15	14932	23610	33390
42 x 120	69	147	15	16435	25986	36750
48						
48 x 48	68	68	17	9192	14533	20553
48 x 54	70	76	17	10062	15910	22500
48 x 60	71	83	17	10733	16971	24000
48 x 66	72	90	17	11511	18201	25740
48 x 72	73	97	17	12558	19856	28080
48 x 80	74	106	17	13475	21305	30130
48 x 84	75	111	17	13962	22076	31220
48 x 96	75	123	17	15456	24438	34560
48 x 108	77	137	17	17418	27540	38947
48 x 120	78	150	17	19170	30311	42866
54						
54 x 54	77	77	19	11319	17897	25310
54 x 60	79	85	19	12075	19092	27000
54 x 66	79	91	19	12951	20478	28960
54 x 72	80	98	19	13853	21904	30977
54 x 80	81	107	19	14866	23505	33242
54 x 84	82	112	19	15706	24834	35120
54 x 96	83	125	19	17388	27492	38880
54 x 108	85	139	19	19154	30285	42830
54 x 120	86	152	19	21131	33411	47250
60						
60 x 60	86	86	21	13156	20801	29417
60 x 66	87	93	21	14387	22748	32170
60 x 72	88	100	21	15392	24337	34418
60 x 80	89	109	21	16847	26637	37670
60 x 84	90	114	21	17450	27591	39020
60 x 96	91	127	21	19320	30547	43200
60 x 108	93	141	21	20918	33074	46774
60 x 120	94	154	21	23023	36402	51480
66						
66 x 66	94	94	21	15831	25032	35400
66 x 72	94	102	21	17267	27301	38610
66 x 80	94	113	21	18168	28727	40625
66 x 84	97	115	21	19199	30356	42930
66 x 96	97	131	21	21252	33602	47520
66 x 108	97	147	21	23465	37102	52470
66 x 120	96	165	21	26359	41677	58941
72						
72 x 72	96	110	21	19731	31198	44120
72 x 80	96	120	21	20631	32620	46132
72 x 84	96	126	21	20943	33114	46830
72 x 96	96	143	21	22733	35945	50833
72 x 108	96	163	21	25599	40475	57240
72 x 120	96	180	21	28174	44548	63000

Air Circulators

Air Circulator Selection Guide

STEP 1: DETERMINE REQUIRED CIRCULATOR TYPE USING THE SELECTION CRITERIA BELOW

	Industrial Circulator	Washdown	Hazardous Location	Automotive Circulator
Environment	Dirty/Humid	Food Processing	Chemicals	Dirty/Humid
Motor	Totally Enclosed	Totally Enclosed	Totally Enclosed	Totally Enclosed
Bearing	Ball/Sleeve	Ball	Ball	Ball
Switch	Pull Chain	—	—	Rocker
Color	Industrial Gray	White/Zinc	Zinc/Gray	Safety Yellow
Certifications	UL/CSA/AMCA Air	UL/CSA/AMCA Air	AMCA Air	UL/CSA/AMCA Air
Hinged Guard	No	No	No	Yes
Oscillating Available	Yes	No	No	No

STEP 2: DETERMINE THE AIR VELOCITY REQUIRED FOR YOUR APPLICATION

Light Activity

- ▶ Assembly, table work, customer service, etc.
- ▶ 200-400 FPM (Feet Per Minute)

Heavy Activity

- ▶ Manufacturing, warehouse, millwork, etc.
- ▶ 500-700 FPM (Feet Per Minute)

STEP 3: DETERMINE THE DISTANCE BETWEEN THE FAN AND TARGET OF THE AIRFLOW

STEP 4: SELECT THE CIRCULATOR USING THE CHART BELOW

Blade Dia. (In.)	HP	Distance From Fan (Ft.)			Velocity Profile	Stock No.
		20	40	60		
Industrial Circulator						
20	1/4	417/265	201/120	—/—	A	3IND20B1Q
20	1/4	417/265	201/120	—/—	A	3IND20B1R
20	1/4	417/265	201/120	—/—	A	3IND20B1E
24	1/4	517/313	187/167	132/49	B	3IND24B1Q
24	1/4	517/313	187/167	132/49	B	3IND24B1R
24	1/4	517/313	187/167	132/49	B	3IND24B1E
30	1/2	769/667	341/319	233/161	C	3IND30D1Q
30	1/2	769/667	341/319	233/161	C	3IND30D1R
30	1/2	769/667	341/319	233/161	C	3IND30D1E
Industrial Oscillating Circulator						
20	1/4	400/350	190/180	90/85	D	3IND20B1A
24	1/4	410/325	185/145	80/60	E	3IND24B1A
30	1/2	710/650	340/310	175/160	F	3IND30D1A
3-Phase						
24	1/4	585	275	155	H	3IND24B7G
30	1/2	750	310	180	J	3IND30D7G
208 Volt						
24	1/4	445	290	95	G	3SPC24B4G
30	1/2	750	310	180	I	3SPC30D4G
277 Volt						
24	1/4	445	290	95	G	3SPC24B5G
30	1/2	750	310	180	I	3SPC30D5G
Washdown						
20	1/4	580	240	155	U	3SPC20B2G
24	1/3	735	245	170	V	3SPC24C2G
30	1/2	750	310	180	J	3SPC30D2G
Hazardous						
24	1/4	520	280	200	W	3SPC24BLG
30	3/4	835	385	295	X	3SPC30ELG
Premium Yellow Circulator						
24	1/4	520/365	265/185	120/85	Y	3YLW24B1H
30	1/4	615/330	320	140	Z	3YLW30B1H

Air Circulators

Industrial Air Circulators — Oscillating and Non-Oscillating

Well-suited for air circulation and cooling of factories, foundries, warehouses, manufacturing facilities, garages, schools, auditoriums, hospitals, large offices and similar applications.

Features and specifications

- All models two speed
- Pedestal Mounted Circulators (3IND20B1Q, 3IND24B1Q and 3IND30D1Q) and Wall/Ceiling Mounted Circulators (3IND20B1R, 3IND24B1R and 3IND30D1R) shipped with mounting accessories included in the box
- Circulator heads are shipped pre-wired and assembled for quick and easy installation
- 115V, 60 Hz, two speed totally enclosed air over (TEAO), ball bearing motors with automatic reset thermal protection
- Stamped aluminum propeller

- Polyester powder coated wire guards comply with OSHA Standard 1910.212, 1/2" max. opening requirement
- Factory wired 10 ft., 3-conductor cord with grounding type molded plug
- Optional mounting accessories: open pedestal base (3CAS02PB), adjustable floor pedestal (3CAS01PB), wall/ceiling bracket (3CAS02WB), suspension bracket (3CAS03SS), I-beam (3CAS01BM)
- Locking tilt adjustment to direct airflow
- Circulator is UL Listed and CSA Certified when used in conjunction with the recommended Air Circulator mounting accessories

Accessories (available separately)

- For more information, see Air Circulator Accessories.
- Open and closed floor pedestal stand.
- Wall/ceiling bracket.
- Suspension bracket.
- I-Beam mount.

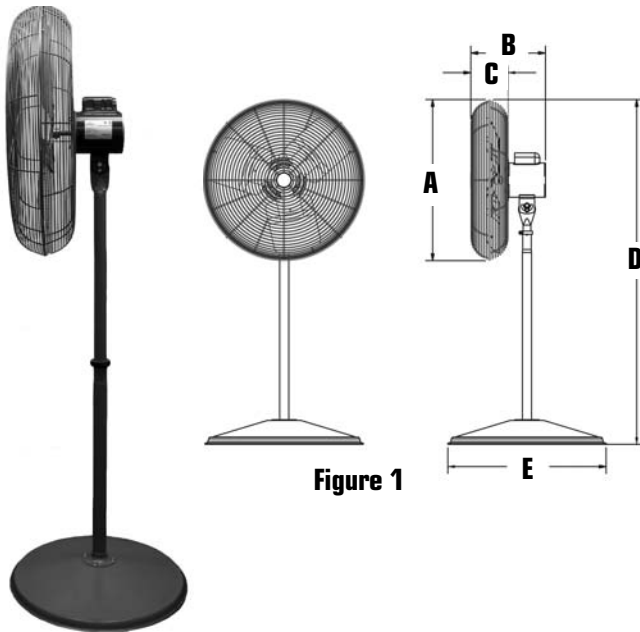

Figure 1

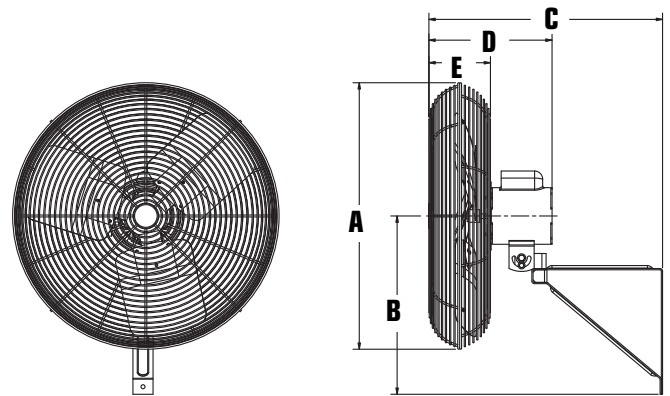

Figure 2



Fantech, Inc. and Systemair Mfg. Inc. certify that the Industrial Air Circulators — Oscillating and Non-Oscillating shown herein are licensed to bear the AMCA Seal. The ratings shown are based on tests and procedures performed in accordance with AMCA Publication 211 and comply with the requirements of the AMCA Certified Ratings Program.

Model No.	Prop. Dia. (In.)	Dimensions (In.)					Oper. Amps	Watts	Volts/Hz	Ship Wt. (lbs.)	Vel. Chart	Thrust	lb/watt
		A	B	C	D	E	CFM	HP	RPM				
PEDESTAL MOUNTED INDUSTRIAL CIRCULATORS (dimensions refer to Figure 1)													
3IND20B1Q	20	22-1/2	12-1/4	6-1/8	56-5/8 min 83-7/8 max	26	3899/3325	1/4	1130/986	1.4/1.3	183/147	115/60	83
3IND24B1Q	24	26-1/2	12-1/4	6-1/8	56-5/8 min 83-7/8 max	26	5494/3101	1/4	1060/633	1.9/1.6	218/156	115/60	87
3IND30D1Q	30	33	14-1/4	8-1/8	56-5/8 min 83-7/8 max	26	9820/7626	1/2	1131/870	4.2/4.0	488/385	115/60	96
WALL/CEILING MOUNTED INDUSTRIAL CIRCULATORS (dimensions refer to Figure 2)													
3IND20B1R	20	22-1/2	17-3/4	23-1/4	12-1/4	6-1/8	3899/3325	1/4	1130/986	1.4/1.3	183/147	115/60	24
3IND24B1R	24	26-1/2	17-3/4	23-1/4	12-1/4	6-1/8	5494/3101	1/4	1060/633	1.9/1.6	218/156	115/60	44
3IND30D1R	30	33	17-3/4	25-1/4	14-1/4	8-1/8	9820/7626	1/2	1131/870	4.2/4.0	488/385	115/60	53
INDUSTRIAL CIRCULATOR HEADS (dimensions refer to Figure 2)													
3IND20B1E	20	22-1/2	—	—	12-1/4	6-1/8	3899/3325	1/4	1130/986	1.4/1.3	183/147	115/60	24
3IND24B1E	24	26-1/2	—	—	12-1/4	6-1/8	5494/3101	1/4	1060/633	1.9/1.6	218/156	115/60	44
3IND30D1E	30	33	—	—	14-1/4	8-1/8	9820/7626	1/2	1131/870	4.2/4.0	488/385	115/60	37
3IND20B1A*	20	22-1/2	—	—	15-9/16	6-1/8	3615/3305	1/4	1161/1081	3.4/1.3	224/125	115/60	32
3IND24B1A*	24	26-1/2	—	—	16-5/8	6-1/8	5530/4460	1/4	1131/893	3.4/1.7	300/207	115/60	35
3IND30D1A*	30	33	—	—	19	8-1/8	9560/8870	1/2	1139/1047	4.5/3.4	474/385	115/60	57

(*) Oscillating models not UL.

Note: AMCA Certified Rating Seal applies to airflow rate at free delivery only. Speed (RPM) is nominal. Performance is based on actual speed of test. Performance ratings do not include the effects of appurtenances (accessories).

Air Circulators

Industrial Air Circulators — Three Phase and 208 & 277 Volt

Three Phase and 208 & 277 Volt Air Circulators

Designed to provide both spot and general cooling for a wide variety of applications including warehouses, factories, manufacturing facilities, garages, machine shops or offices where special voltages are required. The specially designed fan with a choice of either 208 or 277 volt motor is especially convenient for wiring in conjunction with lighting systems and offers reduced amp draw. 277 volt engineered for quick and economical installation in any facility with 480V, 3 phase, 4-wire WYE connected electrical service.

Features and Specifications

- Circulator heads are shipped assembled for quick and easy installation
- Three phase units feature 208-230/460V, 60 Hz, totally enclosed single speed motor wired for 460V from the factory
- 208 & 277 volt units feature 60 Hz, Permanent Split Capacitor (PSC), totally enclosed air over (TEAO) single speed motor with automatic reset thermal protection
- Polyester powder coated wire guards comply with OSHA Standard 1910.212, 1/2" max. opening requirement

- Stamped aluminum propeller resists corrosion
- Circulator heads feature locking tilt adjustment for directional airflow
- Three-phase circulators are UL Listed when used in conjunction with the recommended Air Circulator mounting accessories. Optional mounting accessories include: wall/ceiling bracket (3CASO2WB), suspension bracket (3CASO3SS) and I-beam (3CASO1BM)
- 208 & 277 volt circulators are UL Listed and CSA Certified when used with the recommended Air Circulator mounting accessories; mountings comply with UL 507 requirements for static load. Supplied with wall/ceiling mounting bracket (3CASO2WB). Fan can be mounted to wall, post or ceiling; secondary support cable included

Accessories (available separately)

- For more information, see Air Circulator Accessories.
- Wall/ceiling bracket.
- Suspension bracket.
- I-Beam mount.



Fantech, Inc. and Systemair Mfg. Inc. certify that the Industrial Air Circulators — 208 & 277 Volt shown herein are licensed to bear the AMCA Seal. The ratings shown are based on tests and procedures performed in accordance with AMCA Publication 211 and comply with the requirements of the AMCA Certified Ratings Program.

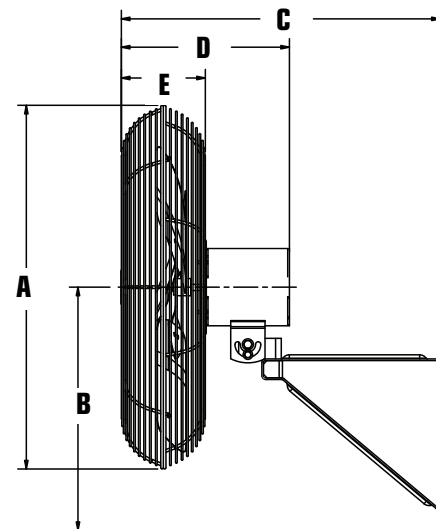
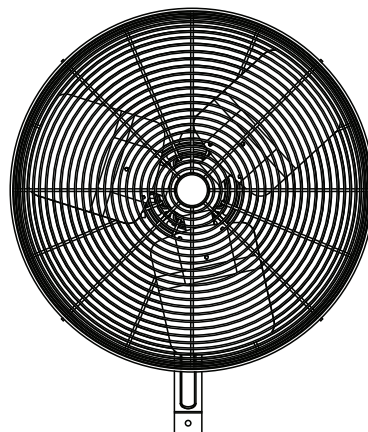
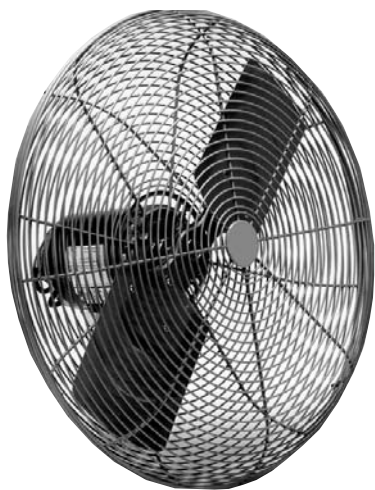

Model No.	Prop. Dia. (In.)	A	Dimensions (In.)					CFM	HP	RPM	Amps	Oper. Watts	Volts/Hz	Ship Wt. (lbs.)	Vel Chart	Thrust lbf/watt	
THREE PHASE CIRCULATOR HEADS																	
3IND24B7G*	24	26-1/2	17-3/4	23	12-1/4	6-1/8	4987	1/4	1751	0.47	238	208-230/460	60	32	H	2.56	0.011
3IND30D7G*	30	33	18-1/16	25-9/16	14-1/4	8-1/8	9326	1/2	1136	0.86	446	208-230/460	60	50	I	5.91	0.013
208 AND 277 VOLT AIR CIRCULATORS																	
3SPC24B4G	24	26-1/2	17-3/4	23	12-1/4	6-1/8	5200	1/4	1739	2.3	337	208/60		36	G	2.77	0.008
3SPC24B5G	24	26-1/4	17-3/4	23	12-1/4	6-1/8	5310	1/4	1735	1.9	334	277/60		38	G	2.77	0.008
3SPC30D4G	30	33	18-1/16	25-9/16	14-1/4	8-1/8	9360	1/2	1114	3.5	561	208/60		61	I	6.39	0.011
3SPC30D5G	30	33	18-1/16	25-9/16	14-1/4	8-1/8	9340	1/2	1116	2.4	563	277/60		62	I	6.54	0.012

(*) Not UL or CSA.

NOTE: AMCA Certified Rating Seal applies to airflow rate at free delivery only. Speed (RPM) is nominal. Performance is based on actual speed of test.

Air Circulators

Industrial Mobile Circulators

Direct-Drive Mobile Circulators

Choose mobile circulators for portable cooling and ventilation. These mobile fans are ideal for spot cooling and ventilating factories, warehouses, laundries, garages, loading docks and similar buildings.

Features and Specifications

- 115V, 60 Hz Heavy Duty, 2-speed motors
- Steel propeller, steel housing and powder coated guards stand up to harsh environments
- Fan includes tilting kit that allows for directional air flow

- Direct-drive eliminates maintenance required with belt and pulley driven models
- Rolls on 7" diameter wheels for easy mobility
- Polyester powder coated wire guards comply with OSHA Standard 1910.212, 1/2" max. opening requirement
- UL Listed and CSA Certified
- Shipped completely assembled and ready to use



Model No.	Propeller Dia.	Height (in.)	Width (in.)	Max Depth (in.)	CFM		RPM	HP	Amps	Ship Wt. (lbs.)
					High	Low				
3DDM24CAH	25	30-1/2	34	19	5800	3600	825/600	1/3	4.2/3.4	80
3DDM30CAH	30	34-1/4	39	19	6890	4687	825/600	1/3	4.5/3.6	85
3DDM36D1H	36	43	45	19	12241	8327	825/600	1/2	6.4/5.2	90
3DDM42D1H	42	49	45	19	15000	9000	825/600	1/2	6.4/5.2	144

Belt-Drive Mobile Circulators

Choose mobile circulators for portable cooling and ventilation. Available with single and two speed operation, these mobile fans are ideal for spot cooling and ventilating factories, warehouses, laundries, garages, loading docks and similar buildings.

Features and Specifications

- 115V, 60 Hz open-type ball bearing motors with automatic thermal protection
- Fan includes tilting kit that allows for directional air flow
- Two speeds for better air velocity control and quiet operation

- Polyester powder coated wire guards comply with OSHA Standard 1910.212, 1/2" max. opening requirement
- UL Listed and CSA Certified
- Prelubricated self-aligning ball bearing pillow blocks
- Balanced propeller, cast-iron drive sheaves and heavy gauge steel housing
- Shipped completely assembled and ready for operation 1910.212, 1/2" max. opening requirement
- UL Listed and CSA Certified
- Shipped completely assembled (except for wheels) and ready to use

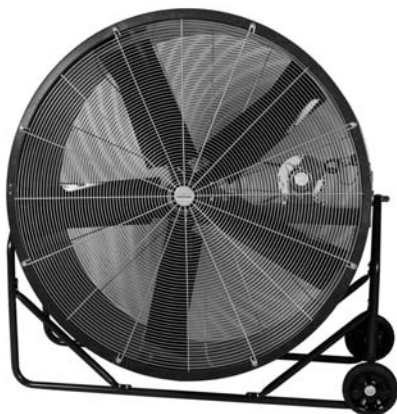

Model No.	Propeller Dia.	Height (in.)	Width (in.)	Max Depth (in.)	CFM		RPM	HP	Amps	Ship Wt. (lbs.)
					High	Low				
3BDM36DAH	36	43	45	20	14,100	9,000	1725/1140	1/2	8.7/5.5	166
3BDM42DAH	42	49	51	21-1/2	18,000	10,000	1725/1140	1/2	8.7/5.5	199
3BDM48EAH	48	55	57	21-1/2	21,200	13,900	1725/1140	3/4	10.3/7.4	239

Air Circulators

High Volume, High Velocity Industrial Air Cannons

Heavy-duty construction is ideal for dependable service in severe operating conditions such as foundries, steel mills, and factories. The ceiling mount design is available in all sizes. The unit rotates and pivots for position adjustment from a steel column or ceiling beam.

Features and specifications

- Designed for dependable service in severe operating conditions such as factories, steel mills and foundries
- Front and rear guards comply with OSHA Standard 1910.212, 1/2" max. opening requirement
- Two position non-tipping stand provides a low and medium fan height
- Welded steel housing has gray polyester finish and can be adjusted to control air direction
- Cast aluminum propellers are spark resistant

- Totally enclosed ball bearing motors rated for continuous duty
- Factory wired 2 ft. long pigtail (SJOW) is provided for hard wiring of the fan
- Optional Accessories: Optional stand with casters offers additional height and mobility for floor units (3HV201PB). Optional wall/column mounting bracket used when installing a ceiling mount high-volume industrial fan to a wall or vertical column (3HV201WB)

Accessories (available separately)

- For more information, see Air Circulator Accessories.
- Open and closed floor pedestal stand.
- Wall/ceiling bracket.
- Suspension bracket.
- I-Beam mount.



Floor Mount

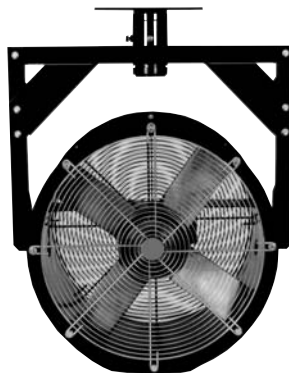

Ceiling Mount

Model No.	Size (In.)	Dimensions (In.)		
		A	B	C
3HV201PB	18	32-7/8	34	14-13/16
	24	32-7/8	34	14-13/16
	30	42-1/16	34	14-13/16
	36	48-1/8	34	14-13/16



Booster Stand

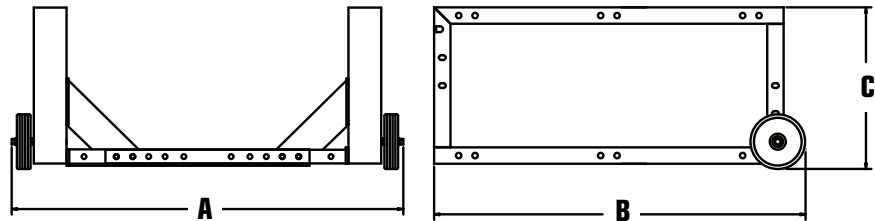

Wall/Column Bracket

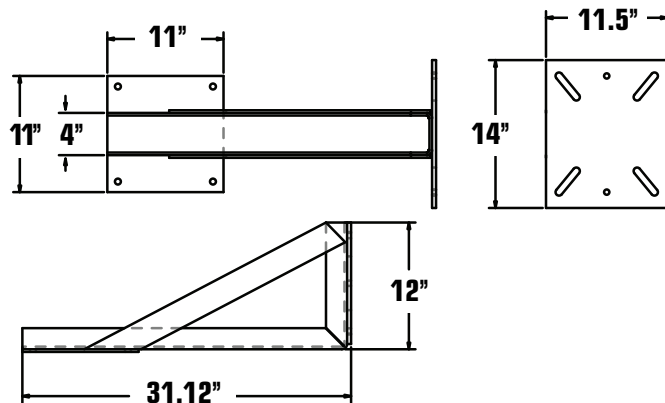

Air Circulators

High Volume, High Velocity Industrial Air Cannons

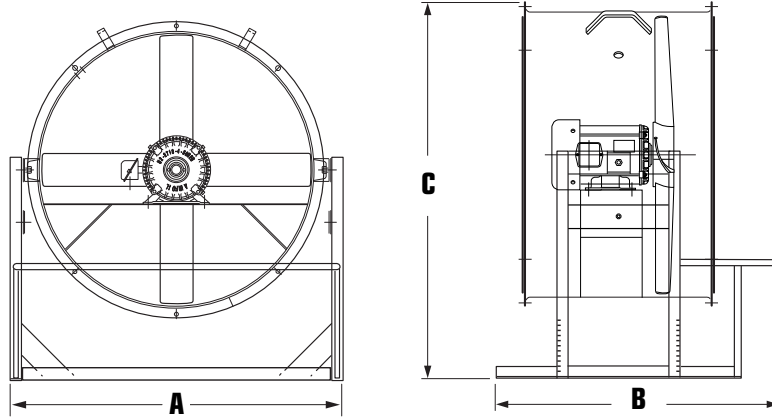

Floor Mount

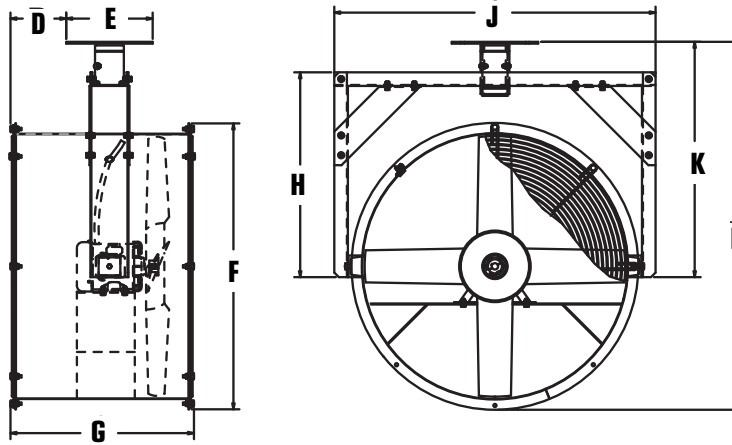

Ceiling Mount

Model No.	Prop. Dia. (In.)	Floor Mount Dimensions (In.)			Ceiling Mount Dimensions (In.)							
		A	B	C	D	E	F	G	H	J	K	L
3HV218	18	26-1/4	36-7/8	31-3/4	4-11/16	12	21-1/2	21-3/8	22-7/8	26-1/4	27-1/16	36-1/4
3HV224	24	32-3/16	36-7/8	34-3/4	5-11/16	12	27-3/8	23-3/8	22-7/8	32-1/4	27-1/16	39-1/4
3HV230	30	37-7/16	36-7/8	37-13/16	5-11/16	12	33-5/8	23-3/8	28-1/2	38-1/2	32-5/8	47-7/8
3HV236	36	44-7/16	36-7/8	40-7/8	6-3/4	12	39-1/2	25-3/8	28-7/16	44-1/2	32-5/8	50-7/8

Floor Mount Model No.	Ceiling Mount Model No.	Prop. Dia. (In.)	CFM	HP	RPM	DB@ 10'	Volts	Phase	Oper. Amps	Ship Wt. (lbs.)	Vel. Chart
3HV218B2F*	3HV218B2C*	18	2773	1/4	1750	65	115/230	1	4.2/2.1	156	O
3HV218BYF	3HV218BYC	18	2792	1/4	1750	65	208-220/440	3	1.0/0.6	156	O
3HV224C2F*	3HV224C2C*	24	4684	1/3	1140	67	115/230	1	6.4/3.2	198	P
3HV224F2F*	3HV224F2C*	24	6995	1	1725	75	115/230	1	13.0/6.5	204	Q
3HV224FYF	3HV224FYC	24	6949	1	1725	75	208-220/440	3	3.3/1.6	200	Q
3HV230H2F*	3HV230H2C*	30	10362	2	1725	82	115/230	1	14.5/7.2	290	R
3HV230HYF	3HV230HYC	30	10029	2	1740	82	208-220/440	3	5.0/2.4	272	R
3HV236F2F*	3HV236F2C*	36	11391	1	1140	79	115/230	1	10.7/5.5	318	S
3HV236FYF	3HV236FYC	36	11418	1	1140	79	208-230/440	3	3.9/1.9	328	S
3HV236HYF	3HV236HYC	36	15053	2	1150	79	208-230/440	3	6.4/3.2	328	T

* Automatic reset thermal protection.

Air Circulators

Special Purpose Circulators

Washdown Air Circulator Heads With Wall/Ceiling Mounting Bracket

Designed to provide both spot and general cooling in food or beverage processing plants, this specialty fan is appropriate for use in washdown or other humid environments.

Features and specifications

- Motor complies with BISSC and NEMA Definition MG1-1.26.5 Standard for waterproof motors
- 115/230V, 60 Hz, permanent split capacitor (PSC), totally enclosed air over (TEAO) single speed motor with automatic reset thermal protection and double-sealed ball bearings
- Stamped aluminum propeller resists corrosion
- Zinc plated guards comply with OSHA Standard 1910.212, 1/2" max. opening requirement
- Circulator heads feature locking tilt adjustment for directional airflow
- Circulator passes UL 507 spray test
- Mountings comply with UL 507 requirements for static load
- Supplied with Wall/ceiling mounting bracket (3CAS02WB). Bracket has adjustable pivot, extends 13," and has (3) 13/32" mounting holes. Fan can be mounted to wall, post or ceiling; secondary support cable included
- Motor painting process uses both durable USDA-approved white epoxy primer and paint

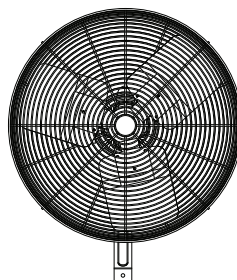

Fantech, Inc. and Systemair Mfg. Inc. certify that the Special Purpose Circulators shown herein are licensed to bear the AMCA Seal. The ratings shown are based on tests and procedures performed in accordance with AMCA Publication 230 and comply with the requirements of the AMCA Certified Ratings Program.

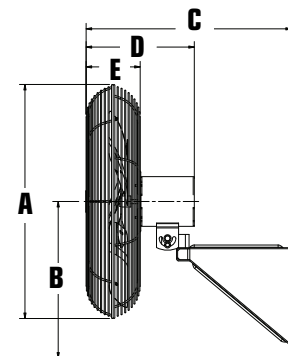

Model No.	Prop. Dia. (In.)	Dimensions (In.)					CFM	HP	RPM	Watts	Amps	Ship Wt. (lbs.)	Vel. Chart	Thrust	lbf/watt	Volts/Hz
		A	B	C	D	E										
3SPC20B2G	20	22-1/2	17-3/4	23	13-11/16	6-1/8	4036	1/4	1744	208	2.6	38	U	2.40	0.012	115/230/60
3SPC24C2G	24	26-1/2	17-3/4	23	13-11/16	6-1/8	6849	1/3	1714	389	4.0	38	V	4.73	0.012	115/230/60
3SPC30D2G	30	33	18-1/16	25-9/16	17-3/16	8-1/8	10001	1/2	1158	495	4.7	58	J	6.38	0.013	115/230/60

NOTE: AMCA certified rating seal applies to airflow rate at free delivery only. Speed (RPM) shown is nominal. Performance is based on actual speed of test.

Hazardous Location Air Circulator Heads With Wall Mounting Bracket

Designed to give maximum performance in hazardous environments. The motor on this specialty circulator is appropriate for uses in atmospheres containing flammable or explosive vapors or gases as defined under Article 500 of the National Electrical Code (NEC).

Features and Specifications

- 115/230V, 60 Hz, totally enclosed fan cooled (TEFC), single speed hazardous location, capacitor start ball bearing motor with automatic reset thermal protection. UL Listed conduit box supplied with motor
- Motors only are UL Listed and CSA Certified for Class I, Div. 1, Group D; and Class II, Div. 1, Groups E, F, and G hazardous locations
- Zinc plated steel guards comply with OSHA Standard 1910.212, 1/2" max. opening requirement
- Spark-resistant cast aluminum propeller
- Supplied with galvanized steel wall bracket for mounting to wall or post
- Mounting brackets allow adjustment for multi-directional airflow
- Secondary support cable included for overhead mounting
- Fan not appropriate for use where paint residue can accumulate on motor

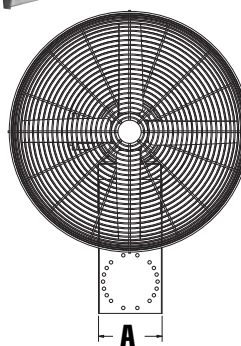
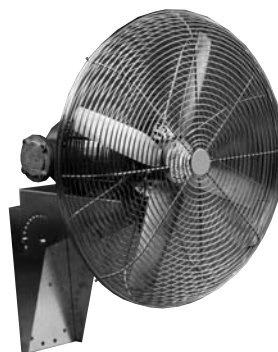

Fantech, Inc. and Systemair Mfg. Inc. certify that the Special Purpose Circulators shown herein are licensed to bear the AMCA Seal. The ratings shown are based on tests and procedures performed in accordance with AMCA Publication 211 and comply with the requirements of the AMCA Certified Ratings Program.

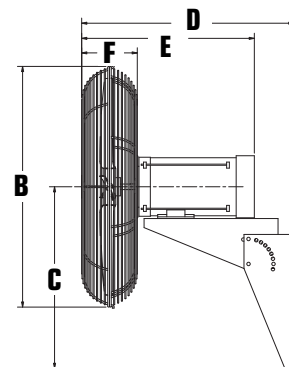

Model No.	Prop. Dia. (In.)	Dimensions (In.)						CFM	HP	RPM	Oper. Watts	Ship Wt. (lbs.)	No. of Blades	Vel. Chart	Thrust	lbf/watt	Volts/Hz	
		A	B	C	D	E	F											
3SPC24BLG	24	7	26-1/2	20	23-3/8	19	6-1/8	5486	1/4	1174	343	6.0/2.9	56	4	W	3.08	0.009	115/230/60
3SPC30ELG	30	7	33	20	25-1/8	21-3/4	7-8/9	10937	3/4	1149	701	7.0/3.5	68	6	X	7.56	0.011	115/230/60

NOTE: AMCA certified rating seal applies to airflow rate at free delivery only. Speed (RPM) shown is nominal. Performance is based on actual speed of test.

Air Circulators

Special Purpose Circulators

Yellow Air Circulator™ Heads

Designed for energy efficient operations in a variety of industrial applications including automotive, industrial and general manufacturing operations. This fan was specifically designed using state-of-the-art computational fluid dynamics and finite element analysis to optimize the CFM/watt, energy efficiency measurement.

Features and specifications

- Circulator heads are shipped pre-wired and assembled for quick and easy installation
- 1/4 HP, totally enclosed air over (TEAO), two speed automatic thermal reset protection, 60 Hz, 115V motor comes with 6 ft., 3-conductor grounded power cord
- Stamped aluminum propeller designed for maximum operating efficiency with the motor (24" size: three-blade propeller; 30" size: two-blade propeller)
- Polyester powder coated wire guards comply with OSHA Standard 1910.212, 1/2" max. opening requirement
- 3 Position drop cord switch ships standard (High/Off/Low)
- Optional 15 ft. extension cord for switch to mount fan on wall or ceiling (3CAS01EC)
- Circulator is UL Listed and CSA Certified when used in conjunction with the recommended Air Circulator mounting accessories
- U.S. pat No. 5,795,133

Accessories (available separately)

- For more information, see Air Circulator Accessories.
- Floor pedestal.
- Wall/ceiling bracket.
- I-Beam mount.

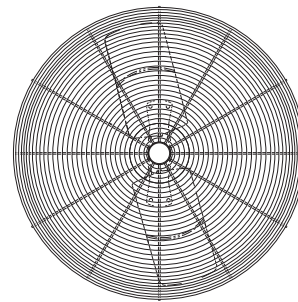
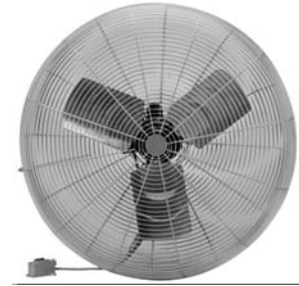
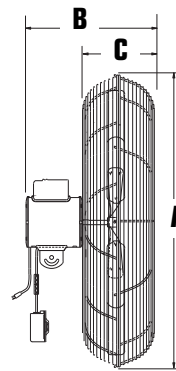

Fantech, Inc. and Systemair Mfg. Inc. certify that the Special Purpose Circulators shown herein are licensed to bear the AMCA Seal. The ratings shown are based on tests and procedures performed in accordance with AMCA Publication 211 and comply with the requirements of the AMCA Certified Ratings Program.

Model No.	Prop. Dia. (In.)	Dimensions (In.)			Guard Dia. (In.)	CFM	HP	RPM	Watts	Oper. Amps	Ship Wt. (lbs.)	Vel Chart	Thrust	lbf/watt	Volts/Hz
		A	B	C											
3YLW24B1H	24	33	14-1/4	8-1/8	33	5635/4435	1/4	1140/886	226/163	2.0/1.5	48	Y	3.20/1.98	0.014/0.012	115/60
3YLW30B1H	30	33	14-1/4	8-1/8	33	7477/4470	1/4	1109/630	269/163	1.9/1.4	48	Z	3.59/1.28	0.013/0.008	115/60

NOTE: AMCA certified rating seal applies to airflow rate at free delivery only. Speed (RPM) shown is nominal. Performance is based on actual speed of test.

Air Circulators

Air Circulator Mounting Accessories

Floor Pedestal Stand

- Model No. 3CAS01PB (gray) or 3CAS03PB (yellow)
- UL Listed and CSA Certified with all circulators except washdown, hazardous location, 3 phase, and 208/277V
- Adjustable column has large diameter tubing (2-1/4" at bottom, 1-3/4" at top) with locking height adjustment collar to securely hold circulator in place
- Polyester coating resists chipping or scratching



Pedestal Stand

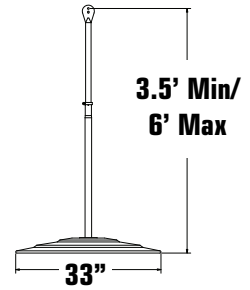

Open Pedestal Stand

- Model No. 3CAS02PB
- Forklift resistant due to heavy duty construction
- UL Listed and CSA Certified with all circulators except washdown, hazardous location, 3 phase, and 208/277V
- Large diameter column adjusts from 3-1/2 ft. to 6 ft. circulator heights



Pedestal Stand

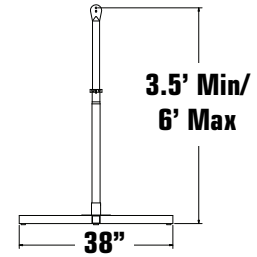

Wall/Ceiling Bracket

- Model No. 3CAS02WB
- UL Listed and CSA Certified with all circulators except hazardous location and oscillating models
- Adjustable pivot bracket allows omnidirectional air circulation
- Includes secondary support cable for additional safety when circulator is mounted overhead



Wall/Ceiling Bracket

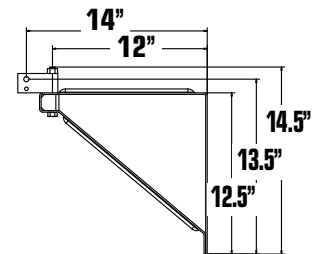

Suspension Bracket

- Model No. 3CAS03SS
- UL Listed and CSA Certified with all non-oscillating circulators except hazardous location
- Allows non-oscillating circulators to be mounted from ceiling beams or rafters
- Includes secondary support cable for additional safety when circulator is mounted overhead



Suspension Bracket

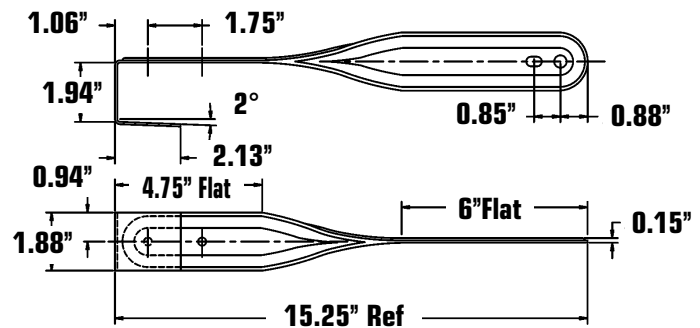

I-Beam Bracket

- Model No. 3CAS01BM
- UL Listed and CSA Certified with all circulators except hazardous location
- Adjustable bracket allows omnidirectional air circulation
- Length can be increased by adding a piece of standard 1-1/2" threaded pipe between the I-beam mount flange and the yoke adapter



I-Beam Mount

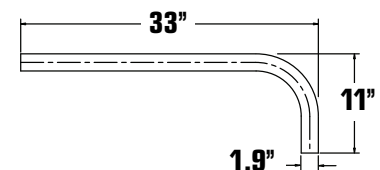
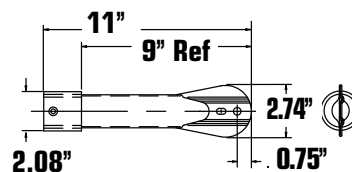

Air Circulators

Air Velocity/Axial Throw Profiles

The air velocity profiles shown below are graphical illustrations of how far a circulator will move the air and the speed of the airflow expressed in feet per minute (FPM).

Industrial Air Circulators

Chart A

Model No.	Prop. Dia. (In.)	Fan Speed	Air Penetration (FPM)			
			20	Distance from Fan (Ft.)		
			40	60	80	
3IND20B1E	20"	High/Low	417/265	201/120	—/—	—/—
3IND20B1Q	20"	High/Low	417/265	201/120	—/—	—/—
3IND20B1R	20"	High/Low	417/265	201/120	—/—	—/—

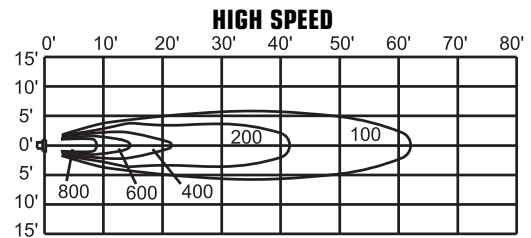

Chart B

Model No.	Prop. Dia. (In.)	Fan Speed	Air Penetration (FPM)			
			20	Distance from Fan (Ft.)		
			40	60	80	
3IND24B1E	24"	High/Low	517/313	187/167	132/49	—/—
3IND24B1Q	24"	High/Low	517/313	187/167	132/49	—/—
3IND24B1R	24"	High/Low	517/313	187/167	132/49	—/—

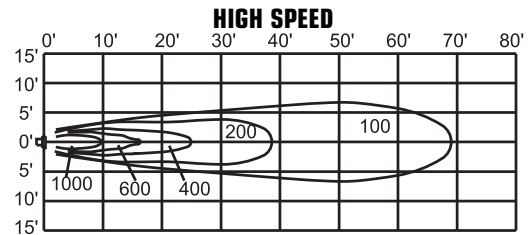

Chart C

Model No.	Prop. Dia. (In.)	Fan Speed	Air Penetration (FPM)			
			20	Distance from Fan (Ft.)		
			40	60	80	
3IND30D1E	30"	High/Low	769/667	341/319	233/161	—/—
3IND30D1Q	30"	High/Low	769/667	341/319	233/161	—/—
3IND24D1R	30"	High/Low	769/667	341/319	233/161	—/—

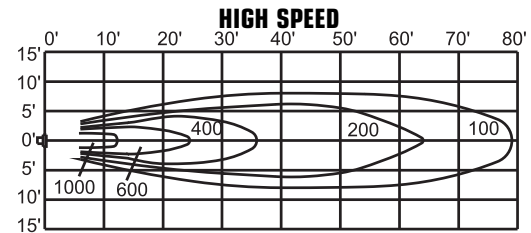

Chart D

Model No.	Prop. Dia. (In.)	Fan Speed	Air Penetration (FPM)			
			20	Distance from Fan (Ft.)		
			40	60	80	
3IND20B1A	20"	High/Low	400/350	190/180	90/85	—/—

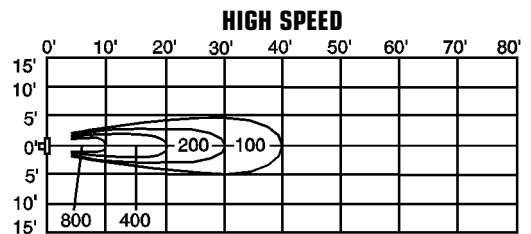
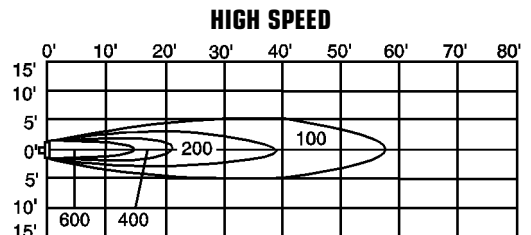

Chart E

Model No.	Prop. Dia. (In.)	Fan Speed	Air Penetration (FPM)			
			20	Distance from Fan (Ft.)		
			40	60	80	
3IND24B1A	24"	High/Low	410/325	185/145	80/60	—/—



Air Circulators

Air Velocity/Axial Throw Profiles

The air velocity profiles shown below are graphical illustrations of how far a circulator will move the air and the speed of the airflow expressed in feet per minute (FPM).

Industrial Air Circulators (Continued)

Chart F

Model No.	Prop. Dia. (In.)	Fan Speed	Air Penetration (FPM)			
			20	40	60	80
3IND30D1A	30"	High/Low	710/650	340/310	175/160	—/—

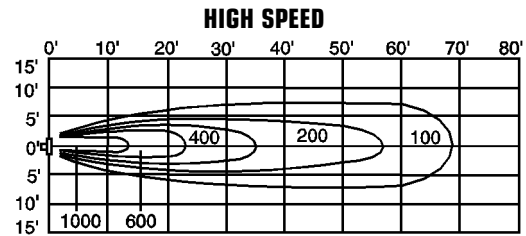

Chart G

Model No.	Prop. Dia. (In.)	Fan Speed	Air Penetration (FPM)			
			20	40	60	80
3SPC24B4G	24"	1725	445	290	95	—
3SPC24B5G	24"	1725	445	290	95	—

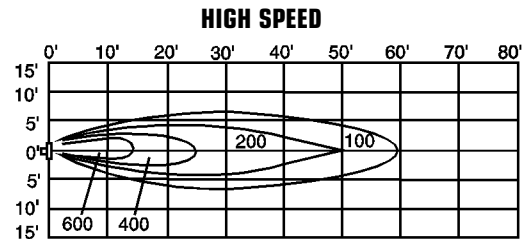

Chart H

Model No.	Prop. Dia. (In.)	Fan Speed	Air Penetration (FPM)			
			20	40	60	80
3IND24B7G	24"	1725	585	275	155	—

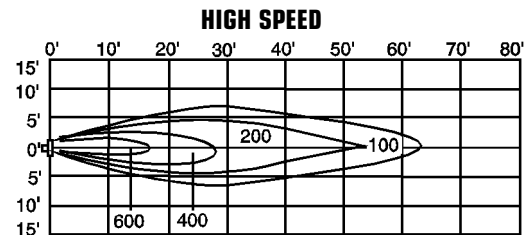

Chart I

Model No.	Prop. Dia. (In.)	Fan Speed	Air Penetration (FPM)			
			20	40	60	80
3SPC30D4G	30"	1075	750	310	180	—
3SPC30D5G	30"	1075	750	310	180	—

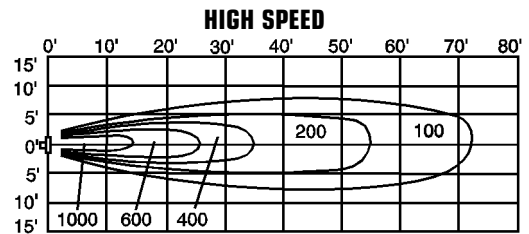
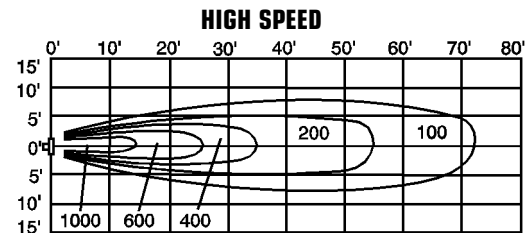

Chart J

Model No.	Prop. Dia. (In.)	Fan Speed	Air Penetration (FPM)			
			20	40	60	80
3IND30D7G	30"	1075	750	310	180	—
3SPC30D2G	30"	1075	750	310	180	—



Air Circulators

Air Velocity/Axial Throw Profiles

The air velocity profiles shown below are graphical illustrations of how far a circulator will move the air and the speed of the airflow expressed in feet per minute (FPM).

High Volume, High Velocity Air Cannons (Continued)

Chart P

Model No.	Prop. Dia. (In.)	Fan Speed	Air Penetration (FPM)			
			20	40	60	80
3HV224C2F	24"	1140	530	350	240	140
3HV224C2C	24"	1140	530	350	240	140

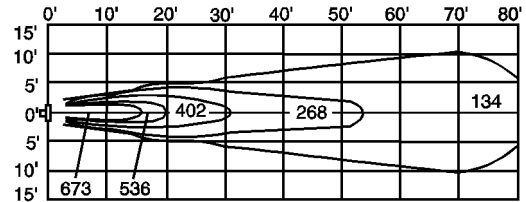

Chart Q

Model No.	Prop. Dia. (In.)	Fan Speed	Air Penetration (FPM)			
			20	40	60	80
3HV224F2F	24"	1725	790	520	360	220
3HV224FYF	24"	1725	790	520	360	220
3HV224F2C	24"	1725	790	520	360	220
3HV224FYC	24"	1725	790	520	360	220

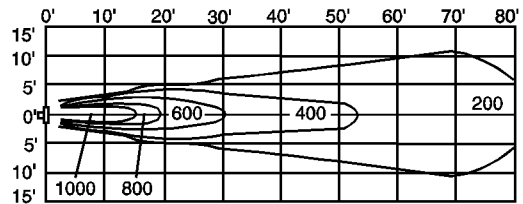

Chart R

Model No.	Prop. Dia. (In.)	Fan Speed	Air Penetration (FPM)			
			20	40	60	80
3HV230H2F	30"	1725	1160	760	520	320
3HV230HYF	30"	1740	1160	760	520	320
3HV230H2C	30"	1725	1160	760	520	320
3HV230HYC	30"	1740	1160	760	520	320

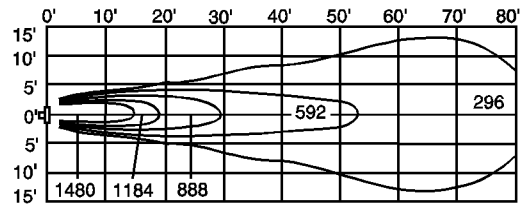

Chart S

Model No.	Prop. Dia. (In.)	Fan Speed	Air Penetration (FPM)			
			20	40	60	80
3HV236F2F	36"	1140	1280	840	580	350
3HV236FYF	36"	1155	1280	840	580	350
3HV236FYC	36"	1155	1280	840	580	350
3HV236F2C	36"	1140	1280	840	580	350

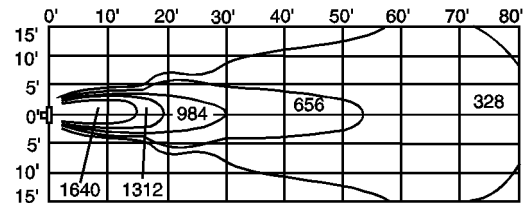
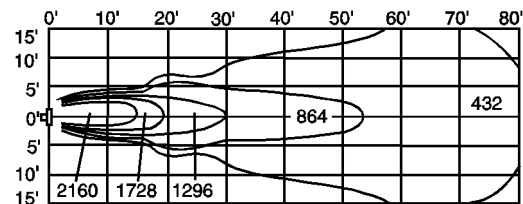

Chart T

Model No.	Prop. Dia. (In.)	Fan Speed	Air Penetration (FPM)			
			20	40	60	80
3HV236HYF	36"	1150	1690	1110	760	460
3HV236HYC	36"	1150	1690	1110	760	460



Air Circulators

Air Velocity/Axial Throw Profiles

The air velocity profiles shown below are graphical illustrations of how far a circulator will move the air and the speed of the airflow expressed in feet per minute (FPM).

Special Purpose Circulators

Chart U

Model No.	Prop. Dia. (In.)	Fan Speed	Air Penetration (FPM)			
			20	40	60	80
3SPC20B2G	20"	1138	580	240	155	75

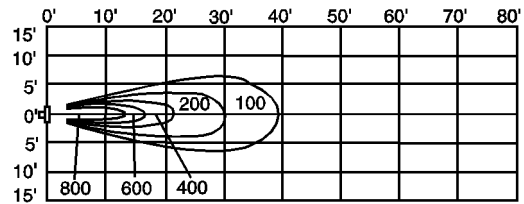

Chart V

Model No.	Prop. Dia. (In.)	Fan Speed	Air Penetration (FPM)			
			20	40	60	80
3SPC24C2G	24"	1718	735	245	170	135

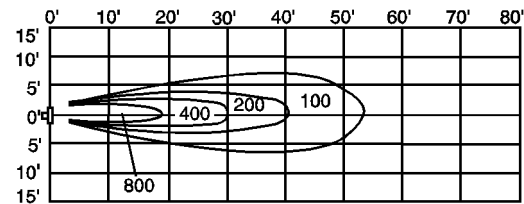

Chart W

Model No.	Prop. Dia. (In.)	Fan Speed	Air Penetration (FPM)			
			20	40	60	80
3SPC24BLG	24"	1176	520	280	200	125

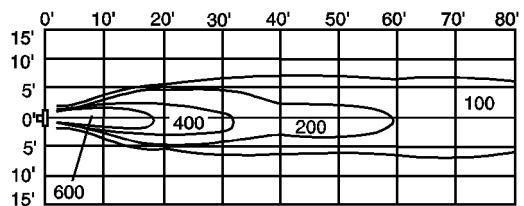

Chart X

Model No.	Prop. Dia. (In.)	Fan Speed	Air Penetration (FPM)			
			20	40	60	80
3SPC30ELG	30"	1150	835	385	295	260

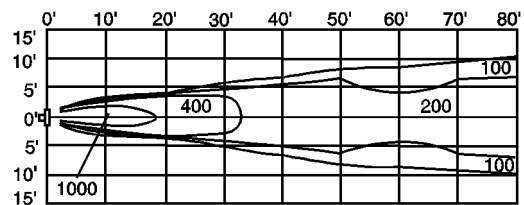
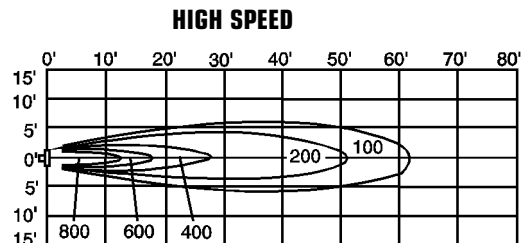

Chart Y

Model No.	Prop. Dia. (In.)	Fan Speed	Air Penetration (FPM)			
			10	20	40	60
3YLW24B1H	24"	High/Low	940/660	520/365	265/185	120/85



Air Circulators

Air Velocity/Axial Throw Profiles

The air velocity profiles shown below are graphical illustrations of how far a circulator will move the air and the speed of the airflow expressed in feet per minute (FPM).

Special Purpose Circulators (Continued)

Chart Z

Model No.	Prop. Dia. (In.)	Fan Speed	Air Penetration (FPM)			
			10	20	40	60
3YLW30B1H	30"	High/Low	865/465	615/330	320/—	140/—

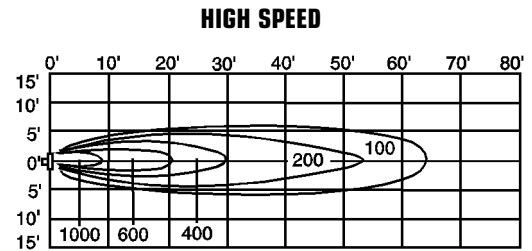

High Volume, High Velocity Air Cannons

Chart O

Model No.	Prop. Dia. (In.)	Fan Speed	Air Penetration (FPM)			
			20	40	60	80
3HV218B2F	18"	1725	440	240	100	—
3HV218BYF	18"	1725	440	240	100	—
3HV218B2C	18"	1725	440	240	100	—
3HV218BYC	18"	1725	440	240	100	—

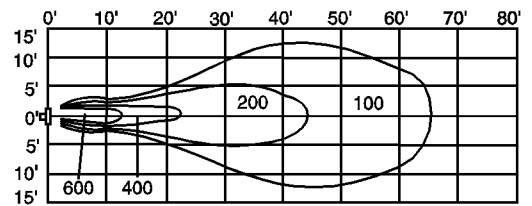

Blowers

Carpet Blower

Highly visible yellow housing is designed to prevent hazards such as falling or tripping over the fan while carpets or floors are drying. Other uses: exhausting foul air, ventilating, and spot cooling.

Features and specifications

- Totally enclosed, two-speed motor for indoor or outdoor use
- Housing has built-in power cord wrap for easy storage
- High density polyethylene housing
- 20-ft., 18/3, SJTW-A water-resistant power cord; cord-connected ground fault interrupter helps prevent hazardous shock
- Blower guards comply with OSHA standards



Model No.	Wheel Dia. (In.)	H	Dimensions (In.)			CFM	Outlet Velocity		Volts	Amps	Ship Wt. (lbs.)
			W	D			FPM	HP			
6BLR11D1H	10-5/8	18-1/16	18-1/16	23-1/2	1474/1107	3500/2870	1/2	115	9.0	44.0	

Blowers

Replacement Furnace Blower

Designed as original equipment and replacement applications for heating, air conditioning and ventilating systems.

Features and specifications

- Assembled motor and blower ready for installation
- Direct drive blowers that are interchangeable with most similar blowers with the same HP ratings
- Vibration reducing welded motor mounting ring

- Sleeve bearings on all motors except 6BLR12FAP and 6BLR12FCP which have ball bearings
- Reinforced blower wheel
- Steel housing with gray enamel finish
- Permanent split-capacitor motor

NOTE: Motors may overload if the blower is operated at static pressures below the performances shown.

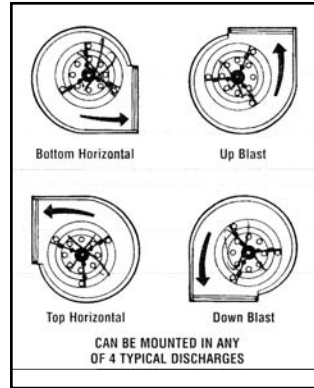

Model No.	Outlet Dimensions (In.)			Overall Dimensions (In.)			Full Load Amps	Capacitor Rating (MFD)
	H	W	D	H	W	D		
6BLR09AAG	7-3/4	9-13/16	12-13/16	10-3/8	12-1/2	2.8	4	
6BLR09BAG	10-1/4	11-3/4	15-1/2	13-7/16	15	4.0	7.5	
6BLR09CAN	10-1/4	11-3/4	15-1/2	14	15	5.1	7.5	
6BLR10DAN	11-3/8	10-1/2	17-3/8	12-5/8	16-9/16	8.8	7.5	
6BLR10EAN	11-3/8	13-1/8	17-3/8	15-3/4	16-9/16	11.2	15	
6BLR12FAP	13-7/16	12-1/4	20-3/8	13-7/8	19-3/8	14.0	30	
6BLR12FCP	13-7/16	12-1/4	20-3/8	13-7/8	19-3/8	7.5	30	

Model No.	Wheel Dia. (In.)			CFM Air Delivery@ RPM Shown								No. Speeds	RPM	HP	Volts 60 Hz.	Amps	Ship Wt. (Lbs)
	Over Rim	Over Blades	W	0.3 SP	0.4 SP	0.5 SP	0.6 SP	0.7 SP	0.8 SP	0.9 SP							
6BLR09AAG	9-15/16	9-1/2	7-1/8	992	961	915	864	726	513	—	1	1075	1/6	115	2.8	23.0	
6BLR09BAG	9-15/16	9-1/2	9-1/2	1529	1517	1483	1416	1326	926	397	1	1075	1/4	115	4.0	29.0	
6BLR09CAN	9-15/16	9-1/2	9-1/2	1938	1798	1739	1656	1543	1407	1084	4	1033	1/3	115	5.1	31.0	
				1495	1492	1461	1406	1342	1122	803							
				1325	1325	1319	1284	1212	990	722							
				—	1165	1164	1142	1033	836	510							

Model No.	Wheel Dia. (In.)			CFM Air Delivery@ RPM Shown								No. Speeds	RPM	HP	Volts 60 Hz.	Amps	Ship Wt. (Lbs)
	Over Rim	Over Blades	W	0.8 SP	0.9 SP	1.0 SP	1.1 SP	1.2 SP	1.25 SP	1.3 SP							
6BLR10DAN	11-1/8	10-5/8	8	—	—	1824	1704	1456	932	—	4	1024	1/2	115	8.8	32.0	
				1653	1616	1550	1470	1010	568	—							
				1430	1392	1341	1255	871	479	—							
				1266	1219	1159	1050	631	405	—							
6BLR10EAN	11-1/8	10-5/8	10-5/8	—	2374	2218	2021	1793	1643	1294	4	1078	3/4	115	11.2	40.0	
				—	2093	1991	1828	1499	1029	558							
				—	1819	1740	1587	981	678	526							
				—	1547	1467	1129	663	558	474							

Model No.	Wheel Dia. (In.)			CFM Air Delivery@ RPM Shown								No. Speeds	RPM	HP	Volts 60 Hz.	Amps	Ship Wt. (Lbs)
	Over Rim	Over Blades	W	1.2 SP	1.3 SP	1.4 SP	1.5 SP	1.6 SP	1.7 SP	1.8 SP							
6BLR12FAP	13-3/16	12-5/8	9-1/2	2780	2775	2740	2660	2530	2170	1850	3	951	1	115	14.0	52.0	
6BLR12FCP	13-3/16	12-5/8	9-1/2	2370	2360	2310	2200	2020	1815	1555							
				1940	1910	1855	1805	1750	1650	—							

Specialty

30" and 36" Assembled Belt-Drive Whole House Fans

Designed to remove stale humid air from living areas and draw in cooler fresh air from outside.

Features and specifications

- 18-gauge steel venturi panel features welded tubular steel supports with gray enamel finish
- 5 blade steel propeller with enamel finish
- Unit comes with 1" x6" wooden plenum and 3/4" x 7/16" adhesive-backed sponge rubber mounting strip for quiet operation
- 115V, 60 Hz, 1725/1140 RPM, split phase, resilient mount motor
- 2-speed permanently lubricated ball bearing motor

- Fully assembled unit that includes a 2-speed switch, 12-hour timer and wood plenum (shutter not included)
- Pre-lubricated ball-bearing pillow blocks are self-aligning
- Air deliveries based on AMCA test standard #210
- Installs horizontally in attic

NOTE: When selecting shutter, be sure that its overall dimensions will fit into the available space.

Accessories (available separately)

- For more information, see Wall Fan Accessories
- Exhaust Shutter.

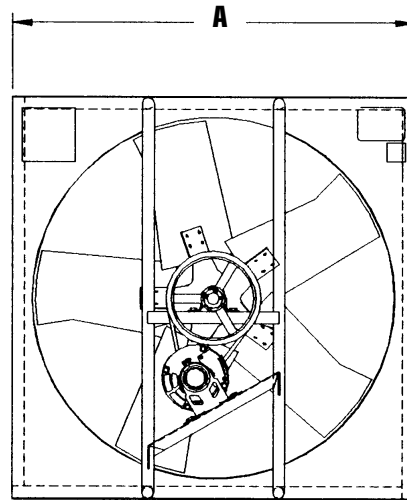

Shutter	Dimensions		Opening Requires (In.)	Free Area (Sq. Ft.)
	L (In.)	W (In.)		
Truss Mount				
1ACC30TS	32	32	30 x 30	4.652
1ACC36TS	36	32	34 x 30	5.981
Ceiling Mount				
1ACC30CS	32	32	30 x 30	4.652
1ACC36CS	38	38	36 x 36	7.293

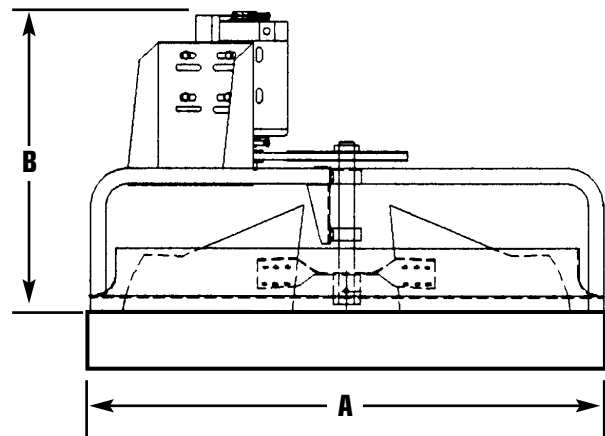

Model No.	Prop. Dia. (In.)	Dimensions (In.)		Speeds	HP	RPM	Amps	Watts	0.0" SP	0.100" SP	Ship Wt. (lbs.)	Optional Shutters	
		A	B									Truss Mount	Ceiling Mount
1WHS30CA	30	34	21-1/8	2	1/3	510/335	6.9/3.8	520/250	7725/5075	6400/2260	79	1ACC30TS	1ACC36CS
1WHS36DA	36	40	20-1/4	2	1/2	450/310	8.7/5.5	660/320	10860/7480	9225/3865	78	1ACC36TS	1ACC36CS

Specialty

Transformer Cooling Fan

Designed to reduce temperatures to oil-filled transformer radiators by forcing cooler air across the heat transfer plates.

Features and specifications

- Weather-resistant guards and weatherproof motor for outdoor use
- 115/230V, 60 Hz, single phase, totally enclosed air over (TEAO), permanently lubricated sealed ball bearing, permanent split capacitor motor has automatic overload protection
- 1/2" shaft with rust inhibitor treatment and shaft-end bearing slinger to protect against dirt and moisture
- Motor drain hold to eliminate condensation buildup
- Fans include mounting brackets, 19-1/2" threaded galvanized rods and hardware
- Weatherproof 8-ft. power cord, pre-wired from factory for 230V operation (UL recognized)
- Class B insulation with Class A temperature rise for extended life

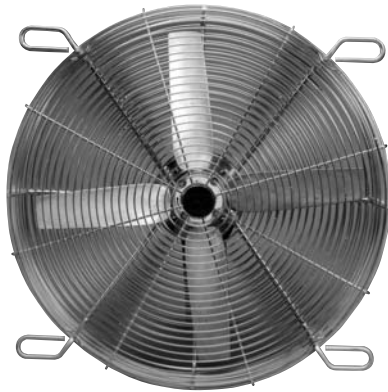

Guard Mount

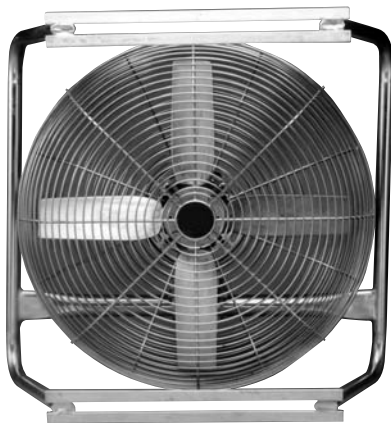
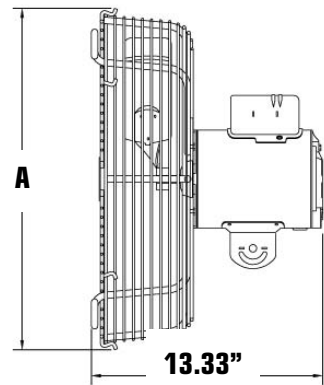
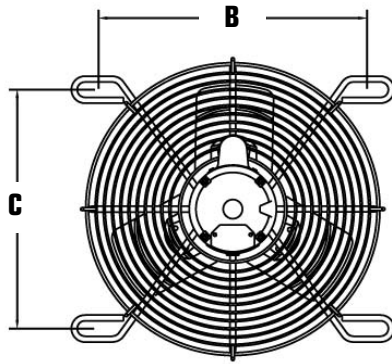

Tubular Mount

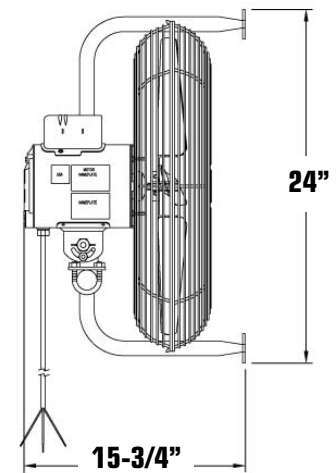
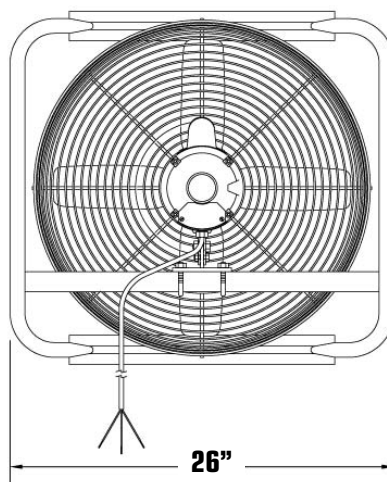

Model No.	Prop. Dia. (In.)	Prop. Construction	CFM	RPM	HP	Volts@ 60 Hz	AMPS	A	Min. B	Max. B	Min. C	Max. C	Ship Wt. (Lbs)
GUARD MOUNT													
3TCF16B2J	16	Stamped	4960	1700	1/4	115/230	3.4/1.7	19	11-3/4	15-11/16	15-11/16	19-1/16	30.0
3TCF16B2K	16	Cast	4560	1700	1/4	115/230	3.4/1.7	19	11-3/4	15-11/16	15-11/16	19-1/16	30.0
3TCF20D2J	20	Stamped	6840	1700	1/2	115/230	5.0/2.5	23	17-3/4	21-1/4	18-1/2	18-1/2	48.4
3TCF20D2K	20	Cast	6600	1700	1/2	115/230	5.0/2.5	23	17-3/4	21-1/4	18-1/2	18-1/2	40.0
3TCF24D2J	24	Stamped	8640	1700	1/2	115/230	5.0/2.5	27	19-7/8	23-3/8	21-1/2	21-1/2	58.2
3TCF24D2K	24	Cast	7900	1700	1/2	115/230	5.0/2.5	27	19-7/8	23-3/8	21-1/2	21-1/2	45.0
TUBULAR MOUNT													
3TCF20D2L	20	Cast	6599	1700	1/2	115/230	5.0/2.5	—	—	—	—	—	58.1

3CAS01MK Flush Mounting Kit (not shown)

Agricultural Exhaust Fans

Direct Drive Exhaust Fans

24" to 48" Direct Drive Agricultural Exhaust Fans – Strand Board Housing

Wood crate fans offer all the benefits of direct-drive in a housing that is economical and ready to install.

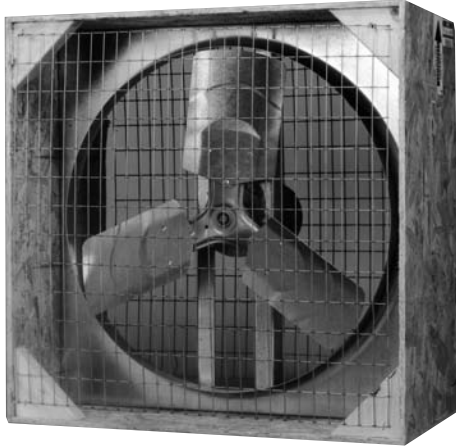

Features and Specifications

- No pulleys or belt to adjust or replace
- G-90 galvanized steel venturi panel 2-blade or 3-blade propeller
- Shipped completely assembled in OSB crate mounting frame
- 1" x 2" wire mesh grid intake and discharge screens;
- Motor has wire leads for easier installation
- TENV(AO), sealed ball bearing, permanent split capacitor motor (except 4DDA48F9V – three phase)
- Automatic reset thermal protection
- Anti-rust shaft protection
- Cup-shaped slinger to protect shaft-end bearing against direct and moisture



Fantech, Inc. and Systemair Mfg. Inc. certify that the Direct Drive Exhaust Fans models 4DDA24D3V and 4DDA48F3V shown herein are licensed to bear the AMCA Seal. The ratings shown are based on tests and procedures performed in accordance with AMCA Publication 211 and comply with the requirements of the AMCA Certified Ratings Program.

Model	Propeller Dia.	CFM Air Delivery at RPM Shown					RPM	HP	Volts 60 Hz.	Max. BHP*
		Free Air	0.05" SP	0.10" SP	0.15" SP					
4DDA24D3V**	24"	5,870	5,650	5,410	5,150	1075	1/2	230	0.57	
4DDA36D2V	36"	10,910	10,360	9,810	9,210	850	1/2	115/230	0.56	
4DDA48F3V**	48"	20,336	18,992	17,495	15,961	850	1	230	1.01	
4DDA48F9V	48"	20,336	18,992	17,495	15,961	850	1	440/460	1.01	

** AMCA Certified

Performance Data for fan mounted in OSB crate without intake or discharge screens or ducts.

*BHP (Brake Horse Power) is maximum horsepower required at delivery shown.

Performance certified is for installation type A-free inlet, free outlet. Performance ratings do not include the effects of appurtenances (accessories).

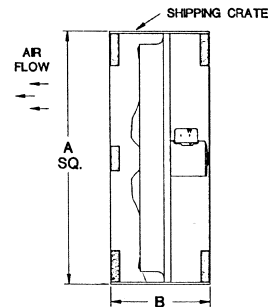

Stock No.	Propeller Dia.	A SQ.	B	Shipping Weight
4DDA36D2V	36"	41"	16"	83

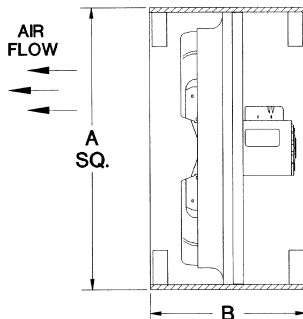

Stock No.	Propeller Dia.	A SQ.	B	Shipping Weight
4DDA24D3V	24"	29"	16"	58

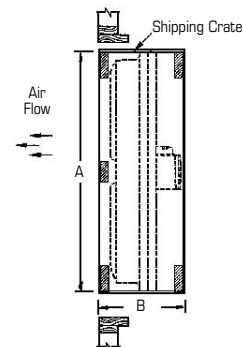

Stock No.	Propeller Dia.	A SQ.	B	Shipping Weight
4DDA48F3V	48"	55"	17"	139
4DDA48F9V	48"	55"	17"	139

Agricultural Exhaust Fans

Direct Drive Exhaust Fans and Belt-Drive Cone Fans

48" Direct Drive Agricultural Fan – Galvanized Housing

Galvanized direct drive box fans are sturdy and corrosion resistant to give you long life, especially in environments with high humidity or excessive moisture.

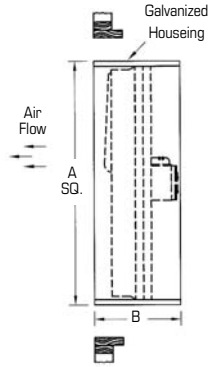
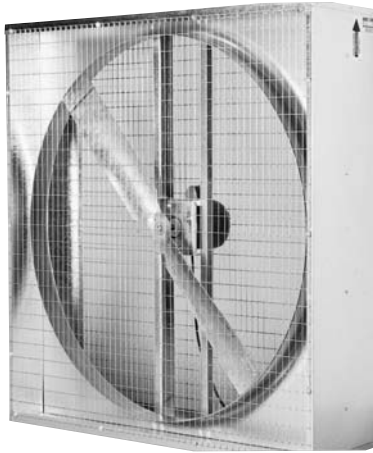

Features and Specifications

- Prepunched holes in sides for easy hanging
- Superior corrosion resistant G-90 galvanized housing
- No pulleys or belt to adjust or replace
- G-90 galvanized steel venturi panel and 2-blade or 3-blade propeller
- Shipped completely assembled in OSB crate mounting frame
- 1" x 2" wire mesh grid intake and discharge screens;
- Motor has wire leads for easier installation
- TENV(AO), sealed ball bearing, permanent split capacitor motor
- Automatic reset thermal protection
- Anti-rust shaft protection
- Cup-shaped slinger to protect shaft-end bearing against direct and moisture

Stock No.	Propeller Dia.	A SQ.	B	Shipping Weight
4DDA48F3U	48"	54-1/4"	16-1/2"	148

Model	Propeller Dia.	CFM Air Delivery at RPM Shown				RPM	HP	Volts 60 Hz.	Max. BHP*
		Free Air	0.05" SP	0.10" SP	0.15" SP				
4DDA48F3U	48"	20,336	18,922	17,495	15,961	850	1	230	1.01

*BHP (Brake Horse Power) is maximum horsepower required at delivery shown. Performance certified is for installation type A-free inlet, free outlet. Speed (RPM) shown is nominal. Performance is based on actual speed of test. Performance ratings do not include the effects of appurtenances (accessories).

36" and 48" Belt-Drive Cone Fan

Special purpose fans designed for easy hanging, low maintenance, easy installation and long life. Ideal for exhausting caustic air from greenhouses, live stock and poultry houses.

Designed with a discharge cone to increase fan performance and efficiency. Ideal for use in livestock and poultry houses.

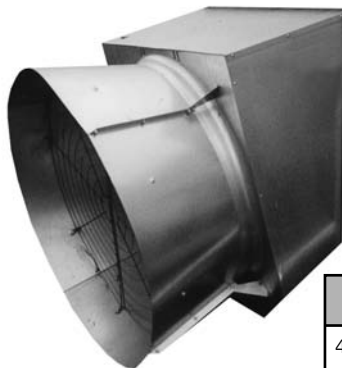

Fantech, Inc. and Systemair Mfg. Inc. certify that the Belt-Drive Cone Fans shown herein are licensed to bear the AMCA Seal. The ratings shown are based on tests and procedures performed in accordance with AMCA Publication 211 and comply with the requirements of the AMCA Certified Ratings Program.

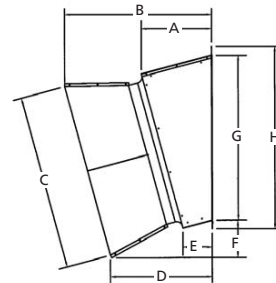

Features and Specifications

- Oversized shutter improves air flow
- Corrosion-resistant fan shaft has permanently lubricated ball bearings
- 4-blade galvanized steel propeller and deep drawn venturi panel
- Includes motor, intake shutter, discharge cone, outlet screen and belt tensioner

Stock No.	Propeller Dia.	A	B	C	D	E	F	G	H	Shipping Wt.
4BDA36D21	36"	22-1/2"	42-1/2"	44-5/8"	31"	12"	11-1/4"	41-1/4"	46-1/2"	200
4BDA48F21	48"	23-1/2"	49-1/4"	59-1/4"	34"	10"	12-3/4"	56"	61-3/4"	200

Model	Propeller Dia.	CFM Air Delivery at RPM Shown				RPM	BHP*	Motor	
		0.0" SP	0.05" SP	0.10" SP	0.15" SP			HP	RPM
4BDA36D21	36"	12,820/16	12,425/15	11,718/13	10,989/12	594	.86	1/2	1725
4BDA48F21	48"	25,028/23	24,005/21	23,111/18	22,110/16	564	1.60	1	1725

*BHP (Brake Horse Power) is maximum horsepower required at .15 static pressure. Does not include drive losses. Performance certified is for installation type A: free inlet, free outlet. Performance ratings include the effects of inlet shutter, discharge guard and belt tensioner. Power rating (BHP) does not include transmission losses.

Agricultural & Horticultural Exhaust Fans

Slantwall Fans

36" and 48" Direct-Drive Slantwall Fans

Slantwall fans give you easy access to the motor and fan from outside, plus the housing slope permits use in high snowfall areas.

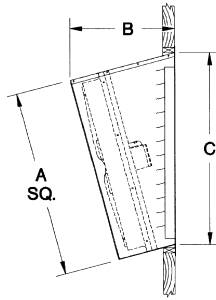
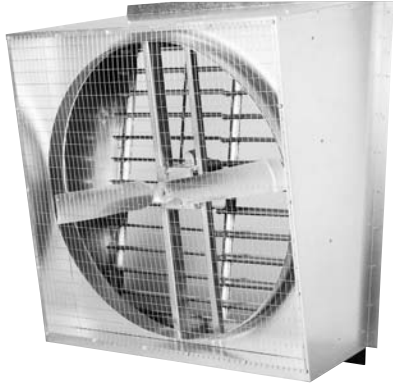

Features and Specifications

- G-90 galvanized steel housing and fan with corrosion resistant shutter
- Shipped completely assembled including fan housing, intake shutter and 1" x 2" mesh discharge screen
- No pulleys or belt to adjust or replace
- Mounts flush to inside of building
- TENV (AO) sealed ball bearing permanent split capacitor motor (switchless)
- Automatic reset thermal protection
- Anti-rust shaft
- Cup-shaped slinger to protect shaft end bearing against dirt and moisture

Stock No.	Propeller			Opening Required		Shipping Weight
	Dia.	A	B	W	H	
4DDA36D2Z	36"	40"	26-3/4"	41-1/2"	41"	200
4DDA48F3Z	48"	54-1/8"	30-1/2"	55-7/8"	55"	360

Model	Propeller Dia.	No. Fan Blades	CFM Air Delivery at RPM Shown				RPM	HP	Volts
			Free Air	0.05" SP	0.10" SP	0.15" SP			
4DDA36D2Z	36"	2	9,725	9,030	8,205	7,290	860	1/2	115/230
			20.1 CFM/Watt	18.0 CFM/Watt	15.7 CFM/Watt	13.4 CFM/Watt			
4DDA48F3Z	48"	2	18,955	17,435	16,050	14,600	850	1	230
			18.7 CFM/Watt	16.9 CFM/Watt	15.3 CFM/Watt	13.8 CFM/Watt			

Performance certified is for installation type A-free inlet, free outlet. Speed (RPM) shown is nominal. Performance is based on actual speed of test. Performance ratings include the effects of metal housing and shutter.

48" Belt-Drive Slantwall Fan

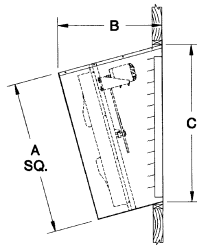
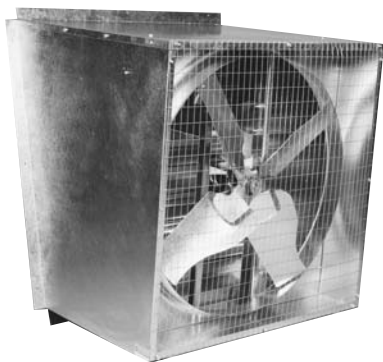

Features and Specifications

- Galvanized steel venturi panel and housing with corrosion resistant shutter
- Galvanized 1" x 2" wire mesh grid discharge screens
- Cast iron drive sheaves and belt shipped with fan
- Includes housing, fan, shutter and motor

Stock No.	Dia.	A	B	C	Opening Required		Shipping Weight
					W	H	
4BDA48F2Z	48"	54-1/8"	38-3/8"	55-7/8"	55"	58-1/2"	293

Model	Propeller Dia.	No. Fan Blades	CFM Air Delivery at RPM Shown				RPM	Volts	HP
			Free Air	0.05" SP	0.10" SP	0.15" SP			
4BDA48F2Z	48"	4	19,300	18,300	17,400	16,100	500	115/230	1

*Performance Data tested at University of Illinois, B.E.S.S. Laboratory.



United States

10048 Industrial Blvd.
Lenexa, KS 66215
800-747-1762; 913-752-6000
Fax: 800-487-9915; 941-752-6466
www.fantech.net; info@fantech.net

Canada

50 Kanalfakt Way
Bouctouche, NB E4S 3M5
800-565-3548; 506-743-9500
Fax: 877-747-8116; 506-743-9600
www.fantech.net; info@fantech.net