

**Model RS-5800**  
**5" (127.0 mm) Storm Resistant Fixed Vertical Louvre**

**Material:**

Material:	6063-T6 Alloy
Nominal Thickness (heads, sills, jambs, & mullions):	0.080" (2.03 mm)
Nominal Blade Thickness:	0.060" (1.52 mm)
Furnished With:	Birdscreen: ½" intercrimp aluminum mesh, 0.063" diameter wire removeable aluminum bird screen in an aluminum frame
Additional Options (at additional cost):	Insect screen (in lieu of bird screen), Continuous clip angles for attachment Sheet blank off, Insulated blank off Sill pans, Flange frames Integrated glazing frames

**Test Summary:**  
**For a 4 Foot by 4 Foot Unit.**

*Tested with mill finish and no screen*

- Free area = 8.67 ft<sup>2</sup> (0.810 m<sup>2</sup>)
- Percent free area = 54.0%
- Free area velocity at the point of beginning water penetration (@ 0.01oz. / ft<sup>2</sup> of free area based on a 15 minute interval test) = 1,250 FPM (6.35 m/s)
- To maintain a CLASS A (99%) effectiveness rating\* with:
  - a 29.1 mph wind speed and rainfall rate of 3 in/hr
    - Max. intake core velocity 5.0 m/s (984 FPM)
    - Max. intake free area velocity 8.0 m/s (1,574 FPM)
- To maintain a CLASS A (99%) effectiveness rating\* with:
  - a 50 mph wind speed and rainfall rate of 8 in/hr
    - Max. intake core velocity 5.0 m/s (984 FPM)
    - Max. intake free area velocity 8.0 m/s (1,574 FPM)

*Tested with 1m<sup>2</sup> core area, mill inish and no screen\**

**Construction Specialties Australia Pty Ltd certifies that the louver model RS-5800 shown herein is licensed to bear the AMCA Seal.** The ratings shown are based on tests and procedures performed in accordance with AMCA Publication 511 and comply with the requirements of the AMCA Certified ratings Program. The AMCA Certified Ratings Seal applies to Wind Driven Rain ratings, Water Penetration Ratings and Air Performance ratings.

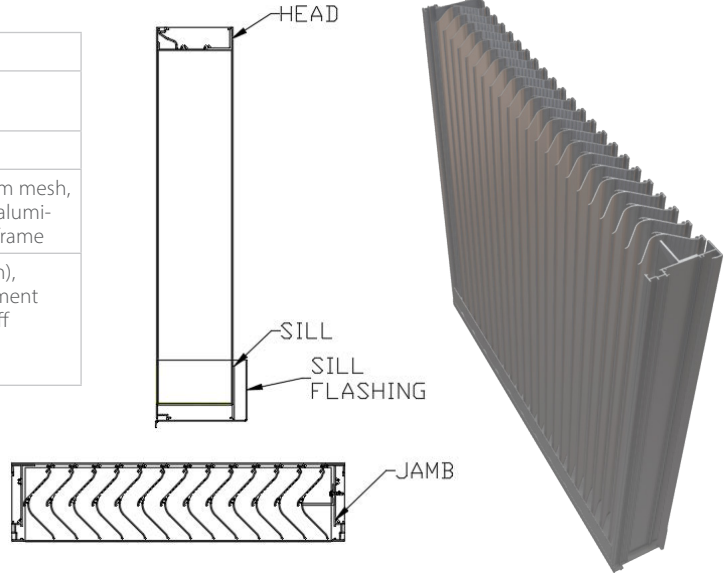

**Discharge Coefficient**  
 Intake Cd = 0.36 (Class 2)  
 AMCA certifies the coefficient class only

**Application and Design**

RS-5800 is tested in accordance with AMCA 500-L Air Performance, Water Penetration and Wind Driven Rain. RS-5800 is tested in accordance with AMCA 550 Test Method for High Velocity Wind Driven Rain Resistant Louvres. RS-5800 is tested in accordance with AMCA 540 Test Method for Louvers Impacted by Wind Borne Debris (Basic Protection, Missile Level D and Enhanced Protection, Missile Level E). Minimum louver section size to be 12"x12".

**Construction Specialties Pty Ltd certifies that the louver model RS-5800 shown herein is approved to bear the AMCA Listing Label.** The ratings shown are based on tests and procedures performed in accordance with AMCA Publications and comply with the requirements of the AMCA Listing Label Program. The AMCA Listing Label applies to High Velocity Wind Driven Rain Resistant Louvres in the fully open position that permits airflow through the louver. The AMCA Listing Label applies to pressure cycle tested Wind Borne Debris Impact Resistant Louvres rated for Enhanced Protection and +/- 160 PSF.

**Model RS-5800**  
**5" (127.0 mm) Storm Resistant Fixed Vertical Louvre**

**Wind Driven Rain Performance:** *Tested with 1m<sup>2</sup> core area, mill finish and no screen*

29.1 mph (13 m/s) & 3" (75 mm) rain per hour

Core Velocity Through Cal. Plate (m/s):	0.0	0.5	1.0	1.5	2.0	2.5	3.0	3.5	4.0	4.5	5.0
Core Velocity Through Louvre (ft/min):	0	132	197	287	380	472	587	680	767	868	984
Free Area Velocity (ft/min):	0	211	315	459	608	755	939	1088	1227	1388	1574
Rating Effectiveness:	A	A	A	A	A	A	A	A	A	A	A
Effectiveness Ratio (%):											100

50 mph (22.3 m/s) & 8" (203 mm) rain per hour

Core Velocity Through Cal. Plate (m/s):	0.0	0.5	1.0	1.5	2.0	2.5	3.0	3.5	4.0	4.5	5.0
Core Velocity Through Louvre (ft/min):	0	96	194	284	400	496	571	679	792	888	984
Free Area Velocity (ft/min):	0	154	310	454	640	793	913	1086	1267	1420	1574
Rating Effectiveness:	A	A	A	A	A	A	A	A	A	A	A
Effectiveness Ratio (%):									99.6	99.6	99.5
Effectiveness Rating:	A = 1 to 0.99			B = 0.989 to 0.95			C = 0.949 to 0.80			D = Below 0.80	

**Water Penetration Statement**

AMCA defines the point of beginning water penetration as the free area velocity at which the AMCA water test has yielded 0.01 or less ounces of water per square foot of louvre free area during a 15-minute test period.

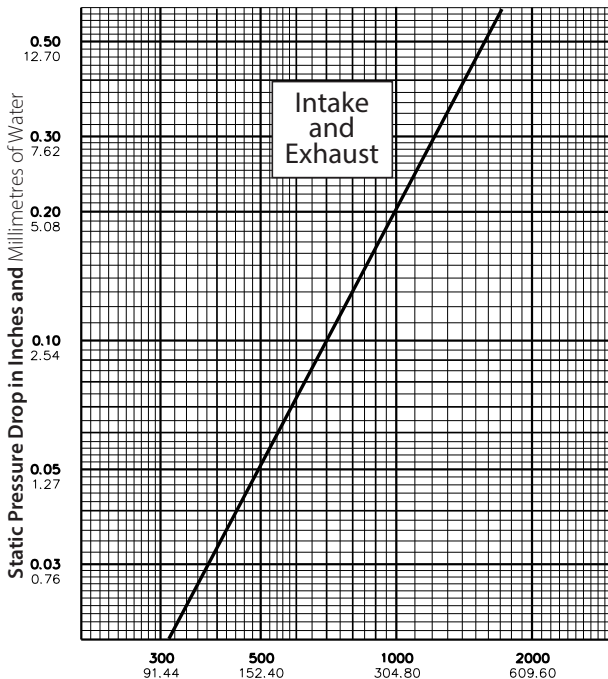

**Air Velocity in Feet and Meters per Minute Through Free Area**

Data corrected to standard air density.  
 48" x 48" louvre tested to figure 5.5.

**Free Area Table** (Free area in sq. feet and sq. metres)

For additional sizes, please visit:

<https://www.c-sgroup.com/architectural-louvers/louvers-airflow-tool>

		Width in Inches and Metres									
		18	24	30	36	42	48	54	60	66	72
Height in Inches and Metres	18	0.46	0.61	0.76	0.91	1.07	1.22	1.37	1.52	1.68	1.83
	0.46	0.08	0.11	0.14	0.18	0.21	0.24	0.28	0.31	0.34	0.38
24	1.19	1.72	2.25	2.77	3.30	3.83	4.36	4.89	5.42	5.94	
	0.61	0.11	0.16	0.21	0.26	0.31	0.36	0.40	0.45	0.50	0.55
30	1.56	2.26	2.95	3.65	4.34	5.04	5.73	6.43	7.13	7.82	
	0.76	0.15	0.21	0.27	0.34	0.40	0.47	0.53	0.60	0.66	0.73
36	1.94	2.80	3.66	4.53	5.39	6.25	7.11	7.97	8.84	9.70	
	0.91	0.18	0.26	0.34	0.42	0.50	0.58	0.66	0.74	0.82	0.90
42	2.31	3.34	4.37	5.40	6.43	7.46	8.49	9.52	10.55	11.57	
	1.07	0.22	0.31	0.41	0.50	0.60	0.69	0.79	0.88	0.98	1.08
48	2.69	3.89	5.08	6.28	7.47	8.67	9.86	11.06	12.26	13.45	
	1.22	0.25	0.36	0.47	0.58	0.69	0.81	0.92	1.03	1.14	1.25
54	3.07	4.43	5.79	7.15	8.52	9.88	11.24	12.60	13.97	15.33	
	1.37	0.28	0.41	0.54	0.66	0.79	0.92	1.04	1.17	1.30	1.42
60	3.44	4.97	6.50	8.03	9.56	11.09	12.62	14.15	15.68	17.20	
	1.52	0.32	0.46	0.60	0.75	0.89	1.03	1.17	1.31	1.46	1.60
66	3.82	5.51	7.21	8.90	10.60	12.30	13.99	15.69	17.39	19.08	
	1.68	0.35	0.51	0.67	0.83	0.98	1.14	1.30	1.46	1.62	1.77
72	4.19	6.05	7.92	9.78	11.64	13.51	15.37	17.23	19.10	20.96	
	1.83	0.39	0.56	0.74	0.91	1.08	1.25	1.43	1.60	1.77	1.95
78	4.57	6.60	8.63	10.66	12.69	14.72	16.75	18.78	20.81	22.84	
	1.98	0.42	0.61	0.80	0.99	1.18	1.37	1.56	1.74	1.93	2.12
84	4.94	7.14	9.34	11.53	13.73	15.93	18.12	20.32	22.52	24.71	
	2.13	0.46	0.66	0.87	1.07	1.28	1.48	1.68	1.89	2.09	2.30
90	5.32	7.68	10.04	12.41	14.77	17.14	19.50	21.86	24.23	26.59	
	2.29	0.49	0.71	0.93	1.15	1.37	1.59	1.81	2.03	2.25	2.47
96	5.69	8.22	10.75	13.28	15.81	18.34	20.88	23.41	25.94	28.47	
	2.44	0.53	0.76	1.00	1.23	1.47	1.70	1.94	2.17	2.41	2.64
102	6.07	8.77	11.46	14.16	16.86	19.55	22.25	24.95	27.65	30.34	
	2.59	0.56	0.81	1.06	1.32	1.57	1.82	2.07	2.32	2.57	2.82
108	6.44	9.31	12.17	15.04	17.90	20.76	23.63	26.49	29.36	32.22	
	2.74	0.60	0.86	1.13	1.40	1.66	1.93	2.20	2.46	2.73	2.99
114	6.82	9.85	12.88	15.91	18.94	21.97	25.00	28.03	31.07	34.10	
	2.90	0.63	0.92	1.20	1.48	1.76	2.04	2.32	2.60	2.89	3.17
120	7.19	10.39	13.59	16.79	19.99	23.18	26.38	29.58	32.78	35.97	
	3.05	0.67	0.97	1.26	1.56	1.86	2.15	2.45	2.75	3.04	3.34

Upper Numerals English Units/Lower Numerals Metric Units