

**INLINE FAN**

# VENTILATION PRODUCTS *for* Car Parking Lot

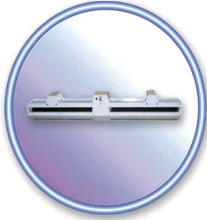

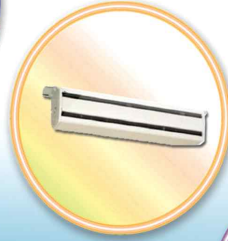

# FD SLIM FAN



## 인 사 말

믿음과 신뢰를 추구하는 기업

고객 만족을 최우선으로 하는 시스템벤트가 되겠습니다.

당사는 'Total Soution the Housing and Parking lot Ventionation System'을 추구하는 회사로 1999년도에 창업하여 현재에 이르고 있습니다.

시스템벤트(주)는 “투명경영과 상호신뢰”의 기업이념을 바탕으로  
전 임직원 모두가 최고의 품질과 최상의 서비스로  
고객만족을 위해서 꾸준히 노력하고 있습니다.

시스템벤트(주) 임직원 일동



시스템벤트(주)가 획득한 DUCT INLINE FAN 의  
AMCA SEAL에 대한 내용입니다.

등급표시는 **AMCA 211** 과 **AMCA 311**에  
의거 Test 및 절차에 따른 것이며, AMCA 보증프로그램의  
요구사항과 일치합니다.

Systemvent Co.,Ltd certifies that the  
DUCT INLINE FAN Model D800  
shown herein are licensed to bear the AMCA SEAL.  
The ratings shown are based on tests and procedures  
performed in accordance with **AMCA Publication 211**  
and **AMCA Publication 311** and comply with the  
requirements of the AMCA Certified Ratings Program.

# INLINE FAN (덕트 연결형)



## 특징

### ● MIXED FLOW IMPELLER 적용

- MIXED FLOW IMPELLER을 사용함으로써 다른 IMPELLER에 비해 효율이 높으며, Fan 기동 시 운전 소음이 낮다.
- ALUMINUM IMPELLER 구조
- IE3 (Premium) Motor 적용
- 소음이 일반 혼합기류형 INLINE FAN 보다 작으며, 저진동으로 설계됨



## IN-LINE FAN

Systemvent

Mixed Flow Type

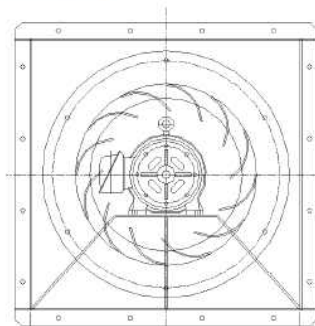

Section View

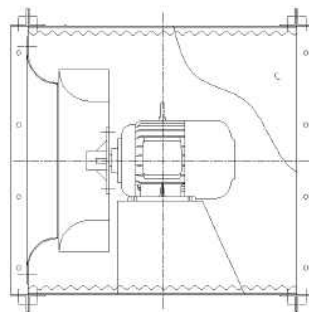

Plan View



# IN-LINE FAN



Systemvent

Model	Det	N	Ps	Q	Input Power	L <sub>wA</sub>
		[r/min]	[Pa]	[m <sup>3</sup> /s]	[kW]	[dB(A)]
<b>D800</b>	1	1170	14	4.902	2.282	95
	2	1170	149	4.408	2.537	91
	3	1170	243	3.968	2.676	91
	4	1170	297	3.682	2.741	90
	5	1170	343	3.381	2.749	89
	6	1170	374	3.111	2.708	87
	7	1170	400	2.864	2.642	86
	8	1170	425	2.588	2.540	86
	9	1170	451	2.225	2.370	86

■ **Hyun-Dai Motor : 3Ph x 380V x 60Hz , 3.7kW/6P, 1170 r/min, 9.0A, Class F, IP55 (S/N 20V020-C09-121-CAM)**

■ Performance Certified is for installation Type B - Free Inlet , Ducted Outlet.

■ Values shown are for Inlet L<sub>wA</sub> sound power levels for installation type B:

free inlet, ducted outlet.

The A-weighted sound ratings shown have been calculated per AMCA International Standard 301

■ Performance ratings do not include the effects of appurtenances (accessories).

■ Hyun-Dai Motor : 3Ph x 380V x 60Hz , 3.7kW/6P, 1170 r/min , 9.0A , F Class ,

IP55 (S/N 20V020-C09-121-CAM)



# IN-LINE FAN



Systemvent

## DIMENSION

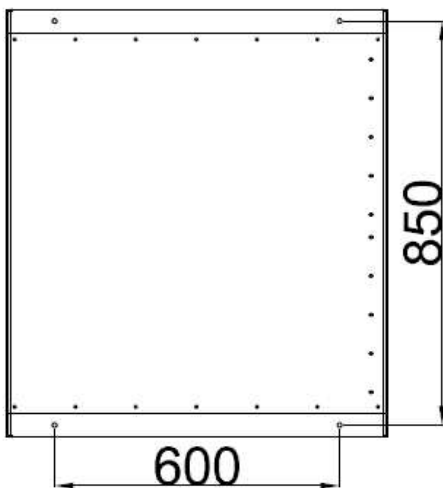
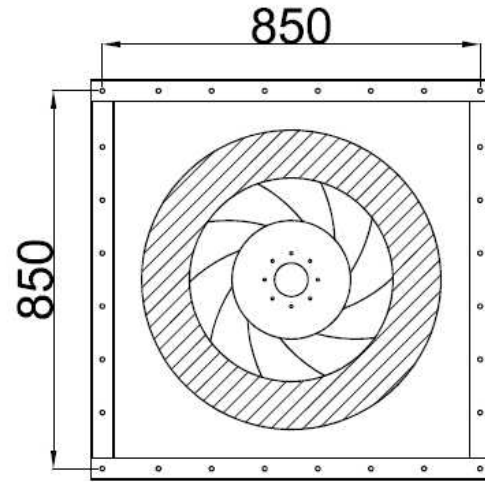
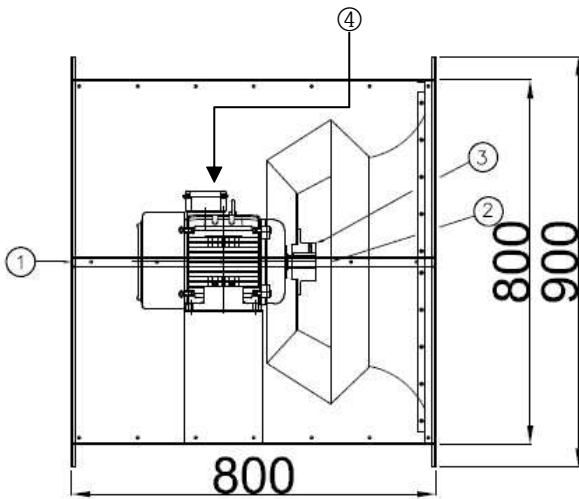

## PART LIST

NO	Description	Material
1	Casing	Galvanized Steel
2	Impeller	Aluminum
3	Boss	GC200
4	Motor	Ass'y



*Your Best Choice for*  
**VENTILATION PRODUCTS**



■ 본사및공장 : 경기도 양주시 광적면 부흥로 925번길, 185-10      Tel : (031) 837-4501 Fax : (031) 837-4509  
 ■ 서울영업소 : 서울시 노원구 하계동 노원로 15길, 10 하계테크노타운 A동 801호      Tel : (02) 949-6011 Fax : (02) 949-6088  
 ■ systemvent@chol.com      ■ www.systemvent.com

We reserved the copyright © for this catalog  
 발행일 : 2018.02.12