

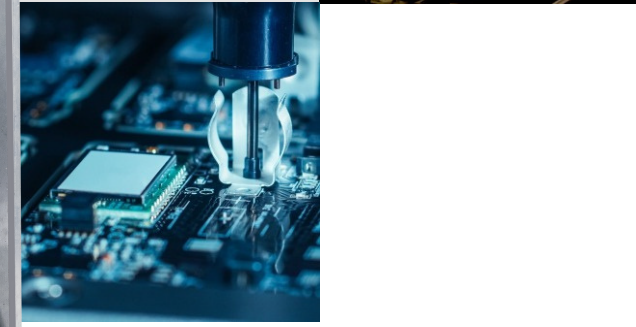

# eBNC Ecowatt EC Plenum Fan Series

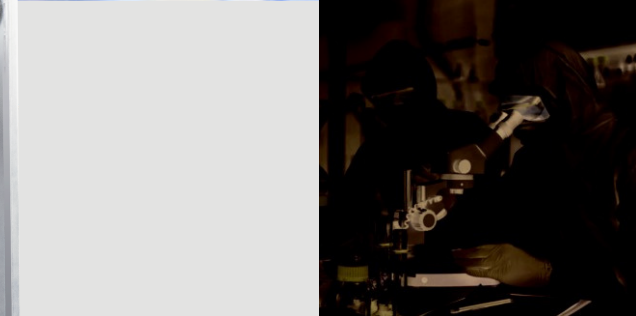

Energy (W) Efficient

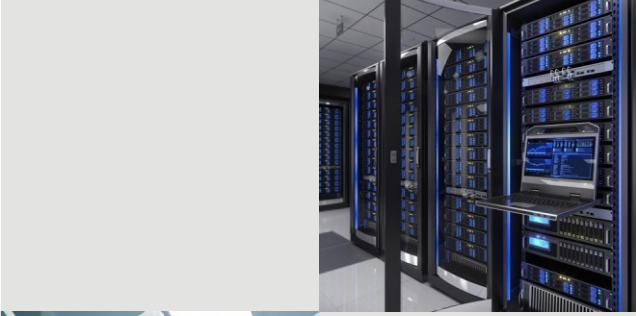

Powerful



Low Noise

# Why KRUGER?

KRUGER has been a leading innovator and manufacturer of residential, commercial and industrial fan application solutions across Asia since 1985. Today with a direct presence in over 18 regions throughout Asia, world class R&D and manufacturing facilities, KRUGER are able to offer their customers unparalleled service and support at a local level. Our customers placed their trust in KRUGER.

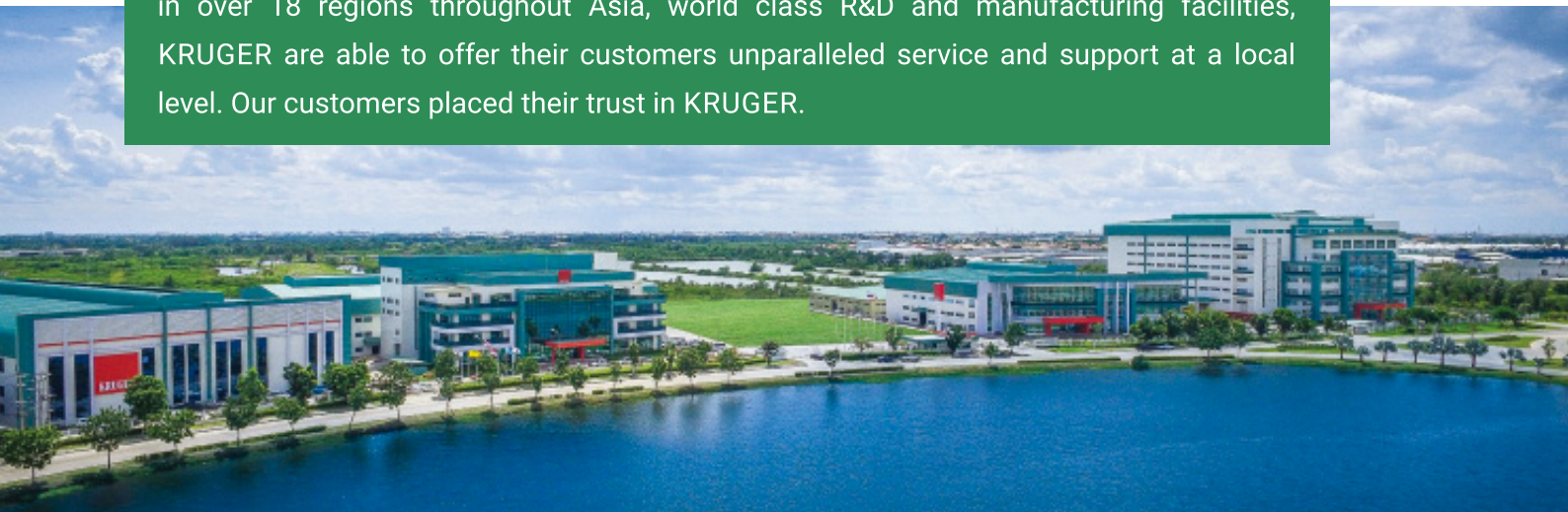

## What is KRUGER eBNC Ecowatt EC Plenum Fan?

The eBNC Ecowatt plenum fan series is a newly developed, compact and highly efficient EC fan solution for air handling units.



### Aluminium Impeller

3<sup>rd</sup> generation aerodynamically optimized plenum fan impeller made of aluminium material for its light weight and excellent matched up with an EC motor integrated with an electronically controlled internal driver motor (ECM) that was carefully selected and rigorously tested that provides an optimized system efficiency.



+

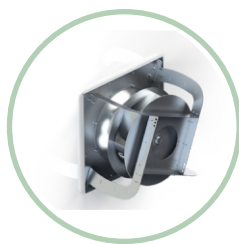

=



### Efficient EC PM Motor

Integrated with a 3-phase controller vector EC motor that is significantly more efficient than conventional fan with AC motors. The permanent magnet increases the electrical efficiency of the motor while eliminates rotor copper and rotor slip losses and the electronic commutation eliminates mechanical wear of the carbon brushes. The end outcome is a far efficient motor.

### Compact & Versatile

With the flow optimized "Boomerang" motor support aerodynamic design and integrated fan and drive assembly, it is a key advantage over conventional fans as it saves 40-50% in fan section length compared to equivalent plenum fan with AC motor. It is lightweight and lesser components makes it a versatile installation for AHU.

Reduce overall length by 40 ~ 50%

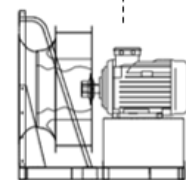
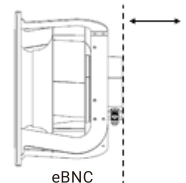

## Speed Control

There are 3 simple wiring methods to control motor speed as shown below:

- Manual speed control 0-10V via Potentiometer.
- Automatic control signal 0-10Vdc or 4-20mA from Demand Controlled Ventilation (DCV) or Building Management System (BMS).
- Automatic control by Modbus RTU program that is connected via RS485 interface.

Full control wiring schematic is available in wiring section.



REB-ECOWATT



Pressure/Airflow Control

## Why Use a KRUGER eBNC Ecowatt EC Plenum Fan?



- ➔ The efficient vector motor allows energy saving over the full and part load operating spectrum while keeping system efficiency at optimum level.
- ➔ Reliable and optimized fan system where the entire fan, EC motor and control system is installed and tested as a complete system.
- ➔ Boomerang brackets allow for optimized aerodynamic airflow across the fan outlet.
- ➔ Low sound level due to good EC motor efficiency plus a light aluminium impeller ensures a low power consumption that leads to reduction in sound levels.
- ➔ Simple, easy to handle, light and compact.



It is a.....  
**SOLUTION**  
for **TOTAL**  
**FAN SYSTEM**  
**EFFICIENCY**  
in AHU at  
**OPTIMUM**  
**POINT** of well  
above **60%**

## Applications

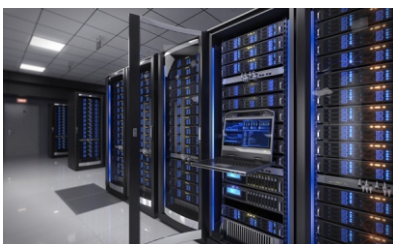

Data Centre

Ideally suited for both new AHU equipment, retrofit applications and VAV systems. Highly efficient, versatile, clean and compact, it is recommended for applications and installation in data centres, clean rooms and other commercial buildings and general industrial applications where a low energy input is required.

The eBNC Ecowatt EC plenum fan is available in a ready-to-install design with aerodynamic "boomerang" spider bracket and a square mounting plate for mounting to AHU support panel or a fan wall.

It is designed for air handling application where the fan wheel operates without a housing but inside a plenum. The fan wheel pressurizes the entire plenum in which the fan is installed. This allows for air ducts to be directly connected from any direction within the plenum. Spider mounting brackets are used for mounting to the AHU.

## Fan Wall Installation

The eBNC Ecowatt EC plenum fan system is also suited for fan wall technology design approach whereby multiple small fans are mounted together in a fan wall. It can be used as a replacement for single large AC fan or even multiples of AC fans. It derives extensive benefits such as footprint savings, lower energy cost over the full and part load spectrum, lower noise, increased reliability and redundancy and lower maintenance cost.



# Summary of Key Specifications

## A Nominal fan diameter ranges from 315mm to 630mm with data at optimum efficiency point below.

Data at Optimum Efficiency Point							
eBNC Ecowatt Model	Airflow (cms)	Ps (Pa)	Motor Inlet Power	SFP w/m <sup>2</sup> /s	Amp (A)	Speed (RPM)	LwO dB(A)
315 LP S5	0.71	768	0.91	1426	1.45	2595	86
315 HP S2	1.06	1764	3.18	2997	4.69	3920	94
355 LP S5	1.03	994	1.73	1669	2.48	2610	86
355 HP S2	1.19	1318	2.66	2230	3.87	3007	93
400 LP S2	1.22	982	2.02	1652	2.98	2230	87
450 LP W3	1.53	758	1.81	1179	2.96	1802	81
500 LP W3	2.13	962	3.18	1494	3.30	1800	88
560 LP W5	2.40	827	3.03	1262	5.19	1500	85
630 LP W5	3.20	636	3.10	968	5.32	1227	83

Nominal Voltage: 380-480VAC, Frequency 50/60 Hz. Performance certified is for installation type A-Free Inlet, Free Outlet. Performance ratings do not include the effects of apertures (accessories). The A-weighted sound ratings shown have been calculated per AMCA International Standard 301. Values shown are for outlet Lwo A sound power levels for installation type A-Free Inlet, Free Outlet.

## B EC Motor Technical Specifications The EC motor information and technical details

EC Motor Information	General	Specific				
Motor Technology	EC/PM	Motor Model	EC112D-L1HL01	EC112D-L1HL03	EM13210A412A4	EM13210A412B2
Efficiency	IE4	eBNC Model	315/355	315/355/400	450/500	560/630
Insulation Class	Class F	Max Motor RPM	2650	4000	1800	1500
Frequency	50/60 Hz	Max Input Power (kW)	1.85	3.25	3.30	3.30
Electrical Characteristic	3 phase AC/380-480V	Max Output Power (kW)	1.51	2.55	3.00	3.00
		Max Input Amp (A)	2.85	6.0	6.05	5.50
Speed Control	PWM Speed Regulation	Max Out Amp (A)	2.7	5.3	-	-
	0-10V Speed Regulation	Motor Designation	S5	S2	W3	W5
	4-20mA Speed Regulation	Enclosure Class	IP54	IP54	IP 55	IP55
	Via MODBUS over RS485 Serial Connection	Nominal Efficiency at Max Speed	89%	84%	91%	91%
Perm Amb Temp °C	-25 to 40	Electronic Enclosure	Aluminium Diecast			
Motor Rotation	CW (viewed towards the rotor)	Weight (kg)	11.2	11.2	30.0	30.0
Bearing	Maintenance Free Ball Bearing	Rotor	External	External	Internal	Internal
		Min Air Speed over Mtr (m/s)	NA	NA	9	9

## C Impeller Design & Specification

Fan Information		
No.	Component	Material
1	Inlet Cone	Galvanized Steel
2	Inlet Cone Frame	Galvanized Steel
3	Wheel	Aluminium
4	Motor	EC Type Motor
5	Motor Support	Galvanized Steel
6	Spider Bracket	Galvanized Steel
7	Hub	Aluminium
8	Bracket	Galvanized Steel
9	Number of Blades	7
10	Fan Weight (casing+ wheel+motor)	eBNC 315 = 23.2 kg eBNC 355 = 25.8 kg eBNC 400 = 28.2 kg eBNC 450 = 58.0 kg eBNC 500 = 63.0 kg eBNC 560 = 63.7 kg eBNC 630 = 71.5 kg

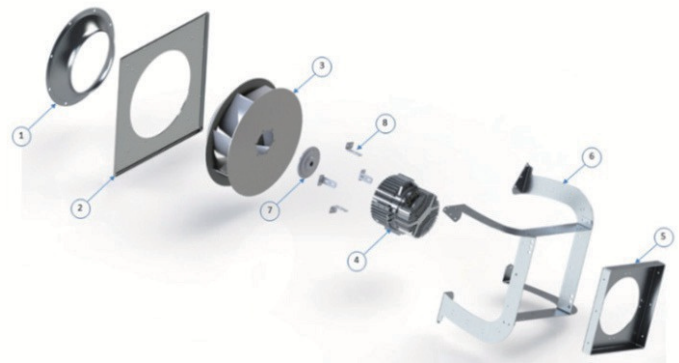

To optimize it for EC motor operations, the wheel of the eBNC Ecowatt is specially made from lightweight aluminium material and with its 7 backwards curved continuously welded and profile blade, it delivers strong static pressure with good efficiency and economical operation.

## D Certification

Kruvent Industries (M) Sdn. Bhd. certifies that the eBNC Ecowatt series shown herein is licensed to bear the AMCA seal. The ratings shown are based on tests and procedures performed in accordance with AMCA Publication 211 and AMCA Publication 311 and comply with the requirements of the AMCA Certified Ratings Program.



## E High Balancing Quality

Motor impeller is statically and dynamically balanced to ISO 14694:2003 and AMCA 204 - G2.5 Standard. G1.0 Standard is available upon request.



# Flow Measurement (Option)

Fan volume flow rate could be estimated through the measurement of differential pressure at the fan inlet. The differential pressure compares the static pressure at the fan inlet cone (narrowest ID) and the static pressure of suction chamber/duct (right before the fan inlet). This measurement is based on the Bernoulli Principle and Continuity Equation, where volume flow rate through a converging cone could be calculated by the static pressure drop across the cone. There are 4 pressure taps installed on the fan inlet cone and these pressure taps are connected to the differential pressure transmitter by pressure tubes as Figure 1.

The volume flow rate of BNC fan can be calculated using the following formula:

$$Q = \frac{Kx \sqrt{\frac{\rho_1}{\rho_2} x \Delta P}}{3600}$$

Where :

Q = Volume flow rate (CMS)

K = K-factor

ΔP = Measured static pressure difference ( Pa ) between the fan inlet and the suction chamber

ρ<sub>1</sub> = Standard air density 1.2 kg/m<sup>3</sup>

ρ<sub>2</sub> = Actual air density ( kg/m<sup>3</sup> )

K-factor of BNC Series

Models	K-Factor
eBNC 315	125
eBNC 355	135
eBNC 400	157
eBNC 450	205
eBNC 500	256
eBNC 560	325
eBNC 630	403

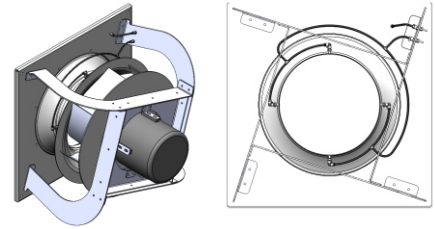
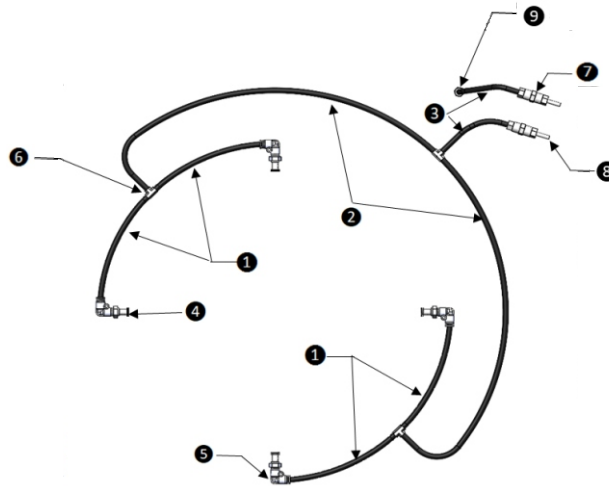

Figure 1

Note: Volume flow rate calculated through the measurement of differential pressure at fan inlet are not licensed by AMCA

## Flow Measurement Items Description



No.	Part	Descriptions	Quantity	No.	Part	Descriptions	Quantity
1		Polyurethane (PU) Tube Black Color Size: O.D. 6 mm. I.D 4 mm. (4x6 mm.). Remark: length must be the same	4	6		Fitting, barbed Size: 5.80 x 5.80 x 5.80 mm.	3
2		Polyurethane (PU) Tube Black Color Size: O.D. 6 mm. I.D 4 mm. (4x6 mm.). Remark: length must be the same	2	7		Coupling Size : FEMALE Thread O.D. 11.53 mm., I.D. 8 mm.	2
3		Polyurethane (PU) Tube Black Color Size: O.D. 6 mm. I.D 4 mm. (4x6 mm.). Remark: length must be the same	2	8		Hose Barb Fitting - Straight Size: Female Thread 9.36 mm., Hose Barb 4.30 mm.	4
4		Nutsert Size: M5	5	9		One-Touch Couplings - Male Thread Fittings Size: One-Touch Couplings O.D 6 mm., I.D 4 mm., Male Thread 4.85 mm.	1
5		One-Touch Couplings - Male Elbows Size: One-Touch Couplings O.D 6 mm., I.D 4 mm., Male Elbows 4.85 mm.	4				

# Dimension of Installation Pressure Taps

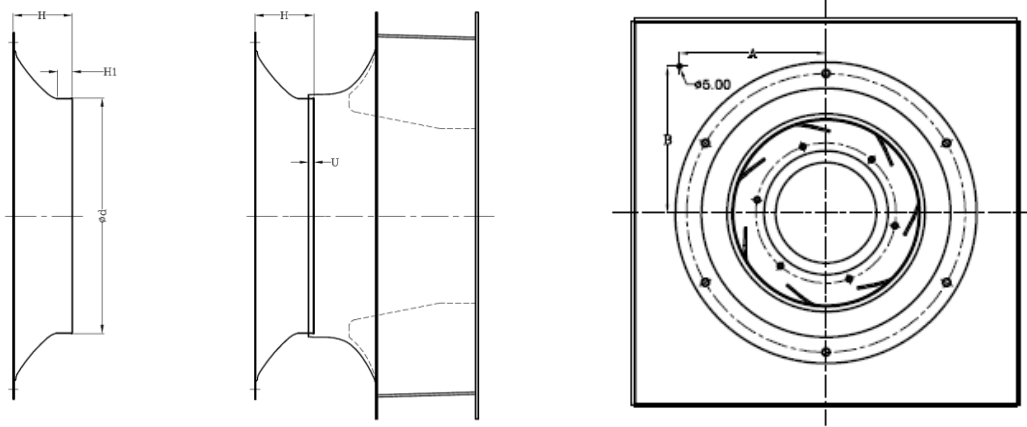

Model	Size	H		H1		d(OD)		U		A	B
	(D)	mm.	ratio(H/D)	mm.	ratio(H1/D)	mm.	ratio(d/D)	mm.	ratio(U/D)	mm.	mm.
eBNC	315	49.5	0.16	13.0	0.04	221.0	0.7	4.0	0.013	150	190
	355	55.5	0.16	13.0	0.04	234.0	0.66	5.0	0.014	175	215
	400	69.4	0.17	13.0	0.03	266.0	0.67	5.0	0.013	190	240
	450	81.0	0.18	15.0	0.03	300.0	0.67	5.0	0.011	200	250
	500	82.1	0.16	15.0	0.03	331.0	0.66	5.0	0.011	220	270
	560	89.5	0.16	15.0	0.03	376.0	0.67	6.0	0.011	250	310
	630	103.1	0.16	22.0	0.03	420.0	0.67	5.0	0.008	290	350

## Nomenclature

1	2	3	4	5	6	7	8	9	10	11	12	13	14	15	16
E	X	X	X	X	X	X	X	X	X	-	X	X	-	X	X
Digit1	Product Category		Digit 10		Motor Frame Size										
'E'	Plenum Fan		'A'		3.25kW/400/3/50-60(EC112D-LHL03)-S2										
Digit 2,3	Fan Series		'B'		1.85kW/400/3/50-60(EC112D-LHL01)-S5										
'NC'	BNC		'C'		3.30kW/380/3/50-60(EM13210A412A4)-W3										
Digit 4	Fan Drive Type		'D'		3.30kW/380/3/50-60(EM13210A412B2)-W5										
'D'	Motor Drive Type		'E'		NA										
Digit 5,6	Pressure Range		'F'		NA										
'P1'	Type P(L)		'G'		NA										
'P2'	Type P(M)		'H'		NA										
'P3'	Type P(H)		Digit 11		None										
'R1'	Type R(L)		Digit 12/13		Revision										
'R2'	Type R(M)		Digit 14		None										
'R3'	Type R(H)		Digit 15,16		Configuration/Others										
'Q1'	Type Q(L)		Digit 00		None										
'Q2'	Type Q(M)														
'Q3'	Type Q(H)														
Digit 7,8,9	Fan Model														
'031'	315	Example													
'035'	355	ENCD P1031B-00-00 - Plenum Fan eBNC 315 LP S5													
'040'	400	ENCD P3031A-00-00 - Plenum Fan eBNC 315 HP S2													
'045'	450	ENCD P1050C-00-00 - Plenum Fan eBNC 500 LP W3													
'050'	500	ENCD P1056D-00-00 - Plenum Fan eBNC 560 LP W5													
'056'	560														
'063'	630														

## Drawings & Dimensions (eBNC 315-630)

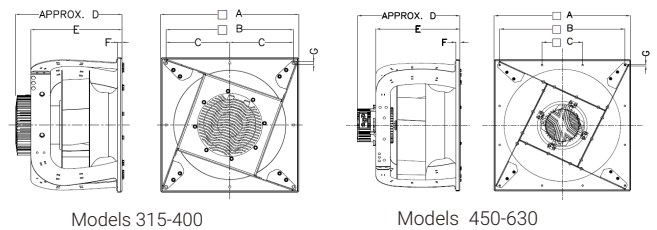

Models	A	B	C	D	E	F	G
315	450	411	205.5	360	305	15	9
355	500	461	230.5	385	330	15	9
400	550	512	256	415	367	15	9
450	600	562	250	520	416	15	9
500	670	622	250	555	453	25	11
560	730	662	250	590	485	25	11
630	840	772	250	630	516	25	11

# Ecowatt eBNC Fan Performance Curves

The graph below shows an overview of the maximum air performance for all the models measured in a chamber test rig. The motor power input ranges from 0.5 kW to 3.3 kW. High performance high-pressure motor is available for models eBNC 315/355.

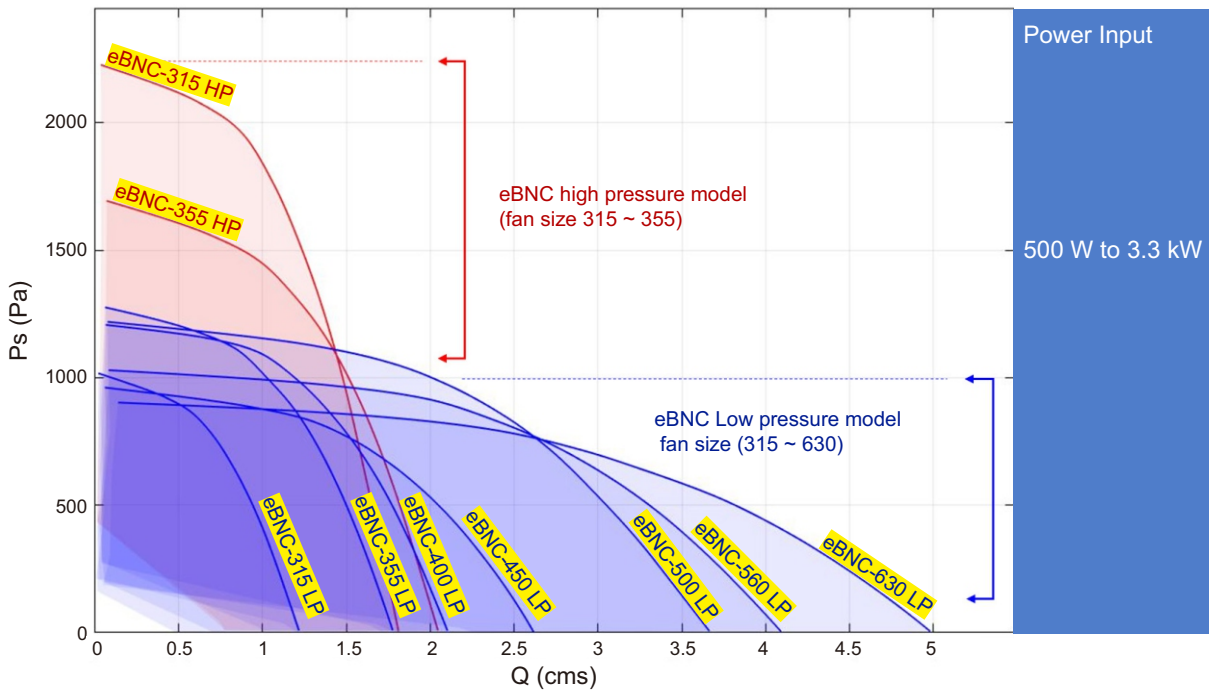

## Effect of Installation Space

Installation in a square box may cause a reduction in air performance.

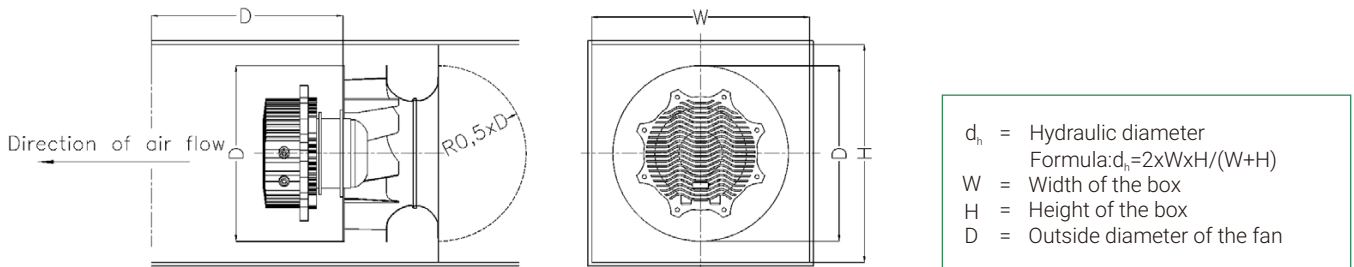

For square cross sections that are greater than 1.9x the impeller diameter, no deduction has to be applied to the catalogue curves. Refer to curve below for appropriate correction factor when  $d_h/D$  is lower than 1.9. Below is an example of square cross sections and respective impeller diameter. Where  $1.9D$  is equal or smaller than cross sectional area of  $W \times H$  divided by  $(W + H)$ , no correction factor is required. Apply the appropriate correction factor as defined in the graph if  $d_h/D$  is smaller than 1.9.

D	w(m)	H(m)	dh/D	dh=2(WxH)/(W+H)	1.9*D ≤ dh
315	1	1	3.17	1.00	0.60
355	1	1	2.82	1.00	0.67
400	1	1	2.50	1.00	0.76
450	1	1	2.22	1.00	0.86
500	1	1	2.00	1.00	0.95
560	1	1	1.79	1.00	1.06
630	1	1	1.59	1.00	1.20

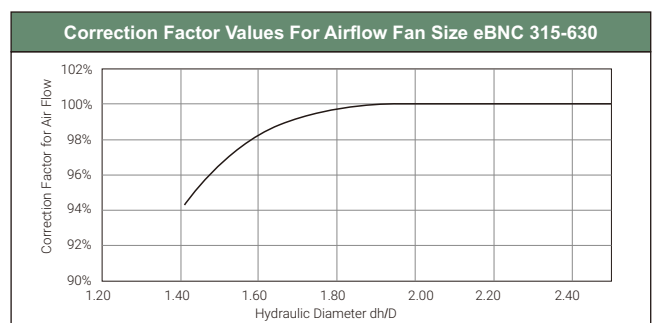

Note: The Correction Factor for Airflow due to Effect of Installation Space are not licensed by AMCA.

# Characteristic Curve

Fan curves at the maximum speed and 3 different partial speeds with FEI curves are available with corresponding curves for power input and fan system static efficiency.

**Characteristic Curve (eBNC 315-LP S5)**

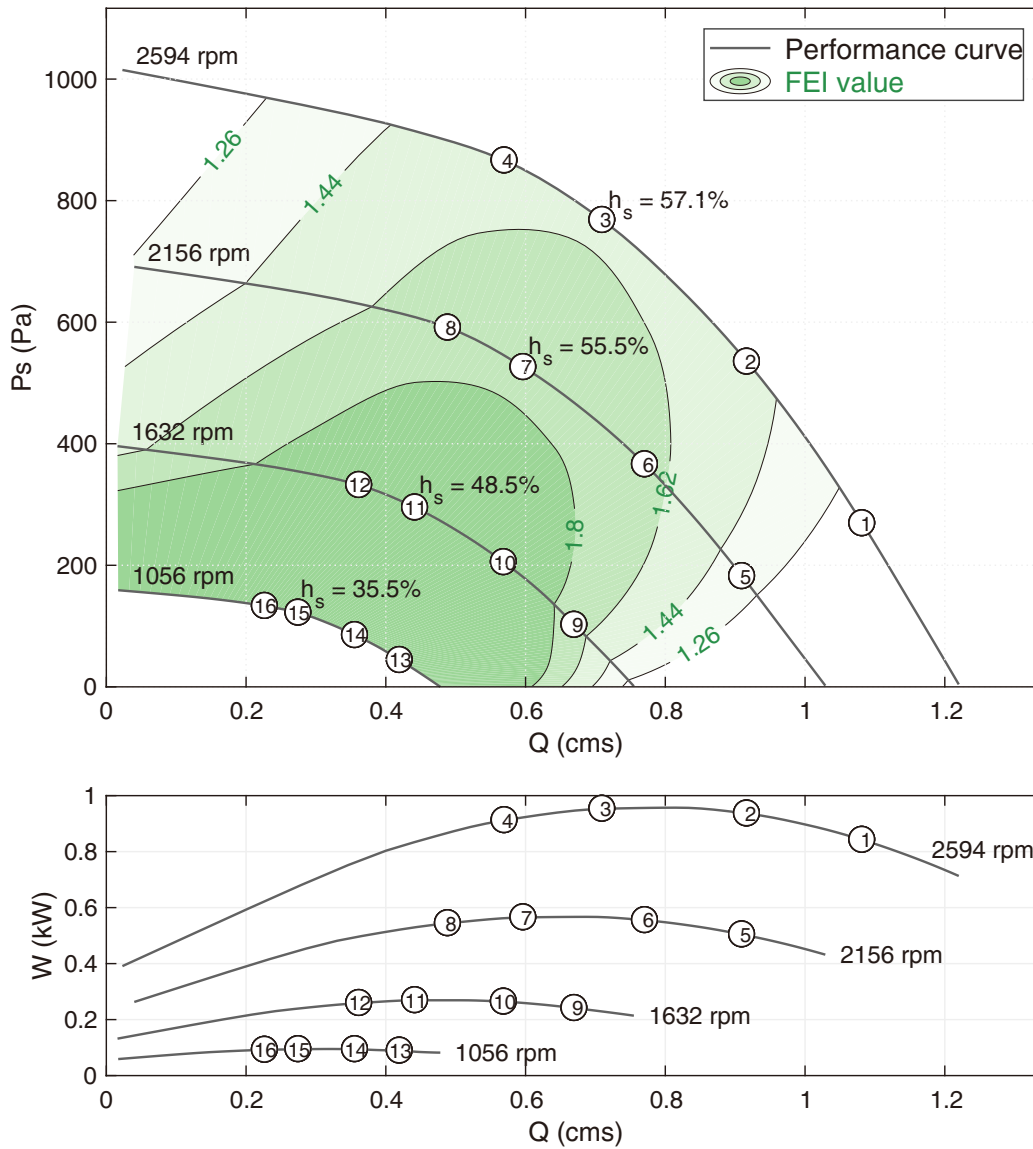

Point	Voltage(V)	Freq (Hz)	Nominal Speed(rpm)	Ps(Pa)	Q(cms)	W(kW)	Hs(%)	I(A)	LwA
1	400	50	2595	269	1.082	0.84	34.5	1.30	88
2	400	50	2595	535	0.917	0.93	52.3	1.42	87
3	400	50	2594	768	0.710	0.95	57.1	1.45	86
4	400	50	2595	866	0.570	0.91	54.0	1.39	87
5	400	50	2156	182	0.910	0.50	32.9	0.84	85
6	400	50	2157	366	0.770	0.55	50.8	0.91	83
7	400	50	2156	526	0.597	0.57	55.5	0.92	82
8	400	50	2156	591	0.489	0.54	53.1	0.88	83
9	400	50	1632	102	0.670	0.24	28.5	0.47	80
10	400	50	1632	205	0.569	0.26	44.1	0.51	78
11	400	50	1632	295	0.442	0.27	48.5	0.53	77
12	400	50	1632	332	0.362	0.26	46.5	0.51	76
13	400	50	1056	44	0.420	0.09	20.6	0.28	74
14	400	50	1056	85	0.356	0.09	32.4	0.29	71
15	400	50	1056	122	0.275	0.09	35.5	0.29	69
16	400	50	1056	133	0.227	0.09	32.9	0.28	69

Speed (RPM) shown is nominal.  
 Performance is based on actual speed of test.  
 Ps is static pressure, Q is airflow, W is power input measured, Hs is fan static efficiency, A is input current, LwO(A) is A-weighted sound power.  
 Performance certified is for installation type A-Free Inlet, Free Outlet.  
 Performance ratings do not include the effects of appurtenances (accessories).  
 FEIs values are calculated in accordance with ANSI/AMCA Standard 208 and are based on wire-to-air measurement, AMCA 211 ratings.  
 FEIs values for fans with specific motors will vary slightly from those shown.  
 The A-weighted sound ratings shown have been calculated per AMCA International Standard 301.  
 Values shown are for outlet Lwo A sound power levels for installation type A-Free Inlet, Free Outlet.  
 EC Motor Model Number EC112D-L1HL01.



# Characteristic Curve (eBNC 315-HP S2)

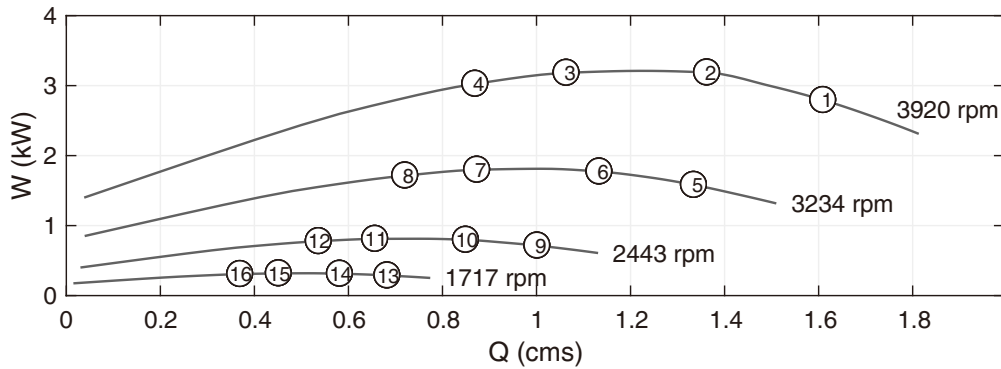
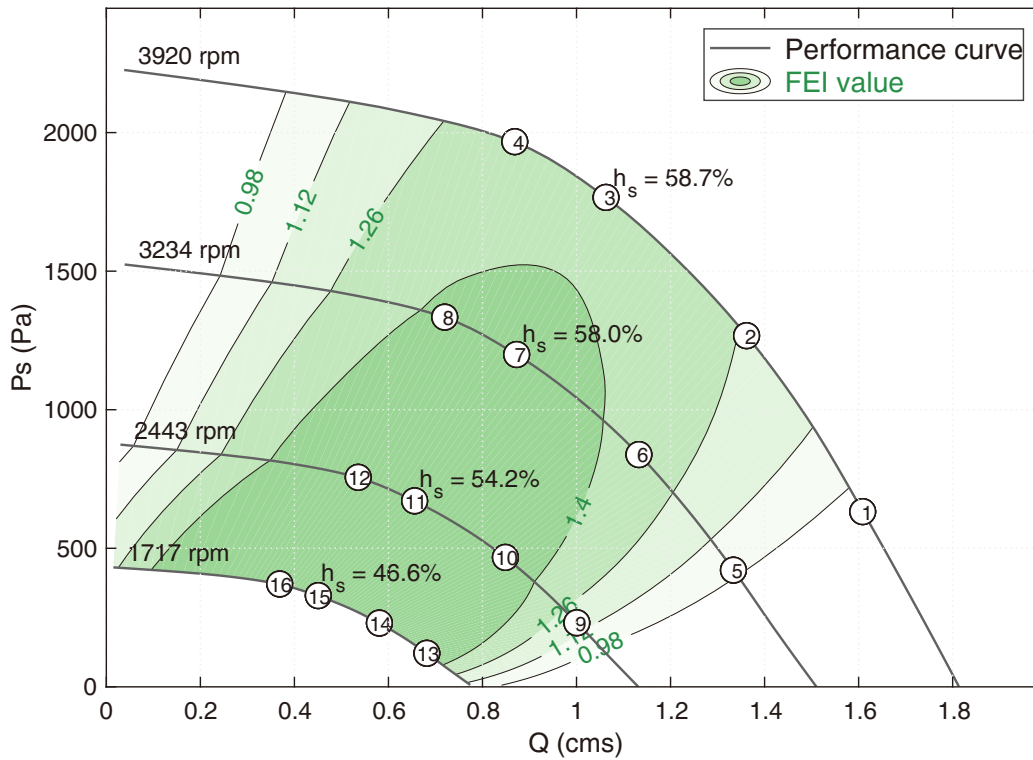

Point	Voltage(V)	Freq (Hz)	Nominal Speed(rpm)	Ps(Pa)	Q(cms)	W(kW)	Hs(%)	I(A)	LwA
1	400	50	3920	630	1.610	2.79	36.3	4.15	99
2	400	50	3920	1265	1.363	3.19	53.9	4.71	96
3	400	50	3920	1764	1.064	3.18	58.7	4.69	95
4	400	50	3920	1965	0.870	3.02	56.2	4.47	96
5	400	50	3234	419	1.335	1.58	35.4	2.44	94
6	400	50	3234	836	1.134	1.77	53.3	2.72	91
7	400	50	3234	1197	0.874	1.80	58.0	2.71	91
8	400	50	3234	1332	0.721	1.71	55.8	2.60	91
9	400	50	2444	229	1.002	0.71	32.1	1.26	88
10	400	50	2444	465	0.850	0.80	49.5	1.39	86
11	400	50	2443	669	0.657	0.81	54.2	1.40	85
12	400	50	2444	754	0.537	0.78	52.0	1.35	86
13	400	50	1717	119	0.683	0.29	28.3	0.67	80
14	400	50	1717	228	0.582	0.31	42.5	0.70	79
15	400	50	1717	327	0.452	0.32	46.6	0.74	78
16	400	50	1717	369	0.370	0.31	44.5	0.78	79

Speed (RPM) shown is nominal.  
 Performance is based on actual speed of test.  
 Ps is static pressure, Q is airflow, W is power input measured, Hs is fan static efficiency, A is input current, LwO(A) is A-weighted sound power.  
 Performance certified is for installation type A-Free Inlet, Free Outlet.  
 Performance ratings do not include the effects of appurtenances (accessories).  
 FEIs values are calculated in accordance with ANSI/AMCA Standard 208 and are based on wire-to-air measurement, AMCA 211 ratings.  
 FEIs values for fans with specific motors will vary slightly from those shown.  
 The A-weighted sound ratings shown have been calculated per AMCA International Standard 301.  
 Values shown are for outlet Lwo A sound power levels for installation type A-Free Inlet, Free Outlet.  
 EC Motor Model Number EC112D-L1HL03.

# Characteristic Curve (eBNC 355-LP S5)

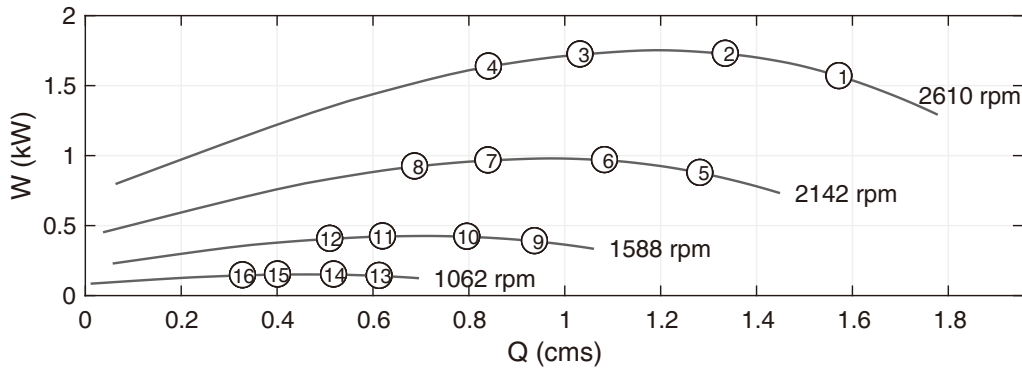
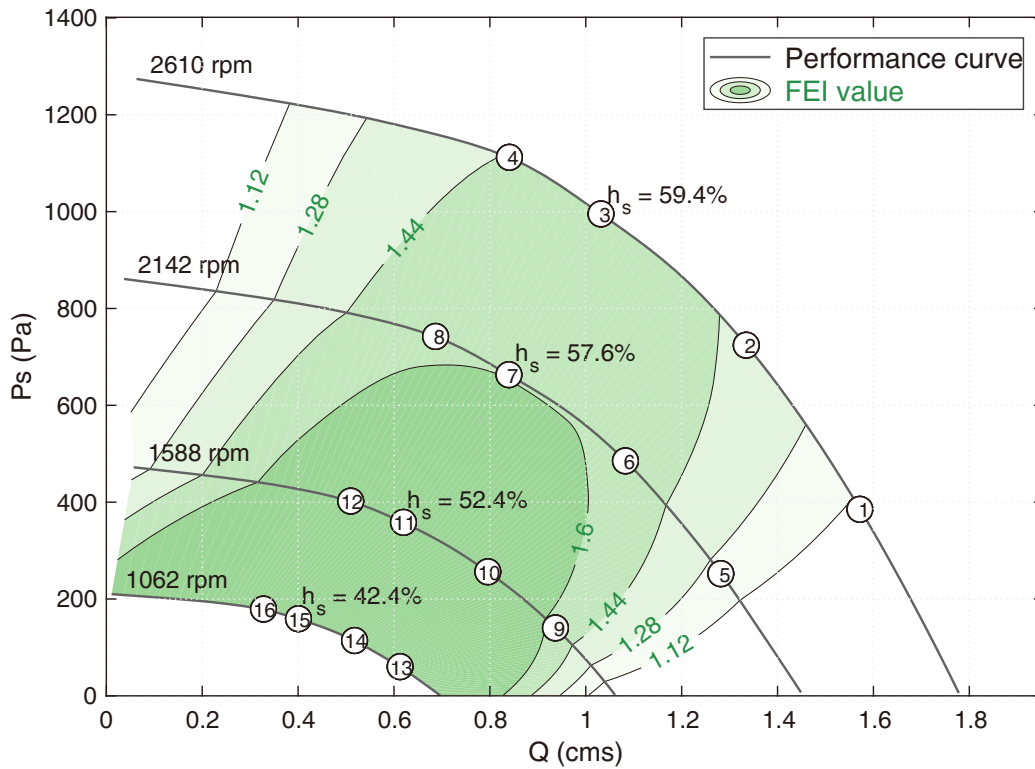

Point	Voltage(V)	Freq (Hz)	Nominal Speed(rpm)	Ps(Pa)	Q(cms)	W(kW)	Hs(%)	I(A)	LwA
1	400	50	2610	384	1.573	1.57	38.5	2.26	91
2	400	50	2611	723	1.336	1.73	55.8	2.48	88
3	400	50	2610	994	1.033	1.72	59.4	2.48	88
4	400	50	2610	1111	0.842	1.64	57.0	2.36	93
5	400	50	2142	251	1.283	0.87	36.7	1.29	86
6	400	50	2142	484	1.084	0.97	54.1	1.42	84
7	400	50	2141	662	0.841	0.97	57.6	1.41	83
8	400	50	2141	741	0.688	0.92	55.2	1.35	84
9	400	50	1588	139	0.938	0.39	33.5	0.66	80
10	400	50	1587	255	0.797	0.42	48.5	0.71	77
11	400	50	1589	357	0.621	0.42	52.4	0.72	76
12	400	50	1587	401	0.511	0.41	50.7	0.69	76
13	400	50	1062	59	0.614	0.14	25.9	0.34	70
14	400	50	1062	113	0.519	0.15	39.2	0.35	67
15	400	50	1062	158	0.402	0.15	42.4	0.35	68
16	400	50	1062	178	0.329	0.14	40.6	0.33	68

Speed (RPM) shown is nominal.  
 Performance is based on actual speed of test.  
 Ps is static pressure, Q is airflow, W is power input measured, Hs is fan static efficiency, A is input current, LwO(A) is A-weighted sound power.  
 Performance certified is for installation type A-Free Inlet, Free Outlet.  
 Performance ratings do not include the effects of appurtenances (accessories).  
 FEIs values are calculated in accordance with ANSI/AMCA Standard 208 and are based on wire-to-air measurement, AMCA 211 ratings.  
 FEIs values for fans with specific motors will vary slightly from those shown.  
 The A-weighted sound ratings shown have been calculated per AMCA International Standard 301.  
 Values shown are for outlet Lwo A sound power levels for installation type A-Free Inlet, Free Outlet.  
 EC Motor Model Number EC112D-L1HL01.

# Characteristic Curve (eBNC 355-HP S2)

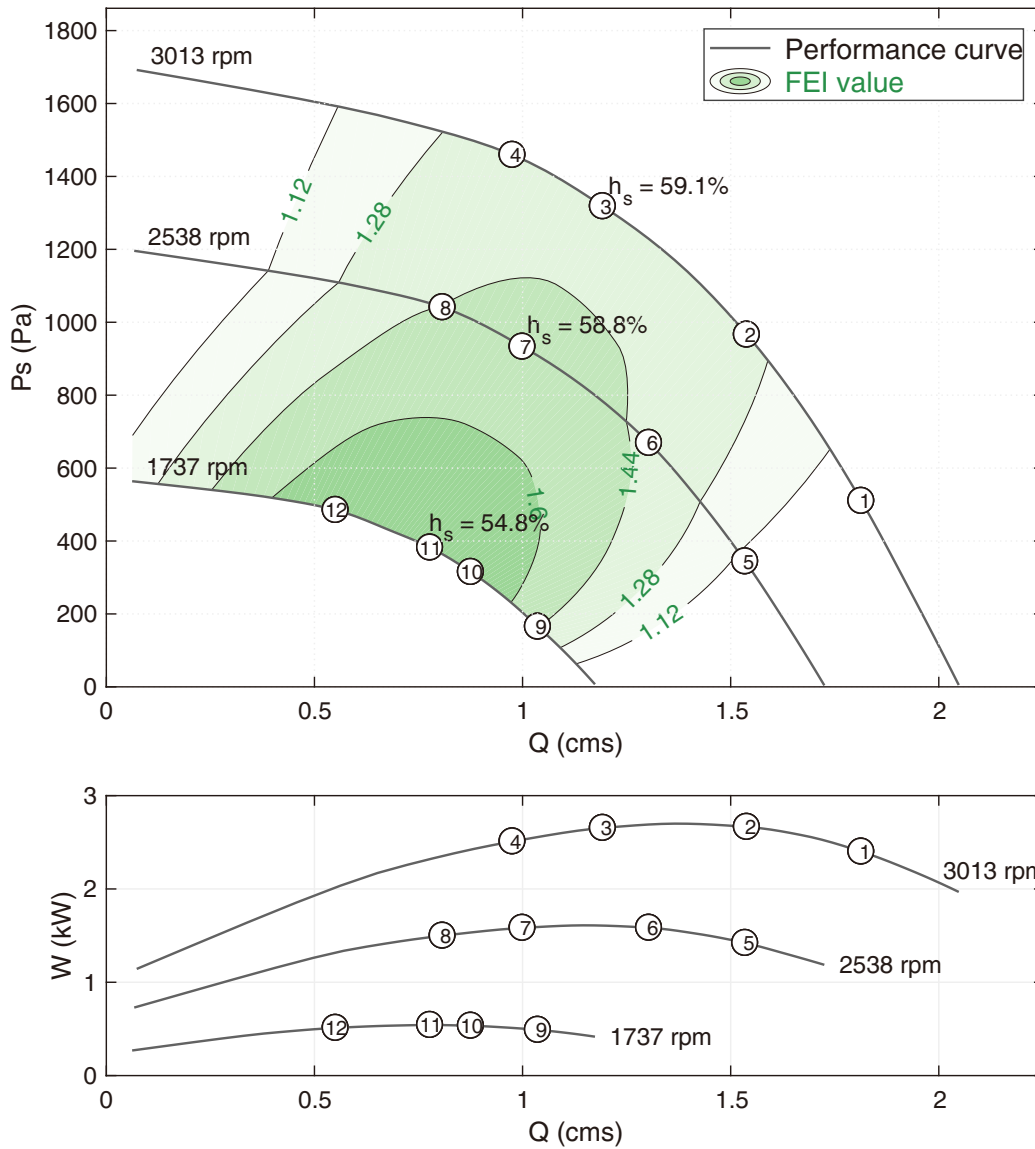

Point	Voltage(V)	Freq (Hz)	Nominal Speed(rpm)	Ps(Pa)	Q(cms)	W(kW)	Hs(%)	I(A)	LwA
1	400	50	3013	510	1.814	2.40	38.5	3.54	95
2	400	50	3013	966	1.539	2.67	55.6	3.91	92
3	400	50	3013	1318	1.193	2.65	59.1	3.87	91
4	400	50	3013	1459	0.976	2.51	56.6	3.66	96
5	400	50	2539	344	1.535	1.42	37.1	2.17	91
6	400	50	2539	669	1.304	1.58	55.0	2.38	88
7	400	50	2538	933	1.000	1.58	58.8	2.37	87
8	400	50	2537	1099	0.603	1.37	48.4	2.06	88
9	400	50	1737	165	1.037	0.49	34.8	0.95	82
10	400	50	1737	315	0.876	0.53	51.6	1.02	79
11	400	50	1740	382	0.778	0.54	54.8	1.04	79
12	400	50	1738	518	0.401	0.46	45.1	0.93	80

Speed (RPM) shown is nominal.  
 Performance is based on actual speed of test.  
 Ps is static pressure, Q is airflow, W is power input measured, Hs is fan static efficiency, A is input current, LwO(A) is A-weighted sound power.  
 Performance certified is for installation type A-Free Inlet, Free Outlet.  
 Performance ratings do not include the effects of appurtenances (accessories).  
 FEIs values are calculated in accordance with ANSI/AMCA Standard 208 and are based on wire-to-air measurement, AMCA 211 ratings.  
 FEIs values for fans with specific motors will vary slightly from those shown.  
 The A-weighted sound ratings shown have been calculated per AMCA International Standard 301.  
 Values shown are for outlet Lwo A sound power levels for installation type A-Free Inlet, Free Outlet.  
 EC Motor Model Number EC112D-L1HL03.

# Characteristic Curve (eBNC 400-LP S2)

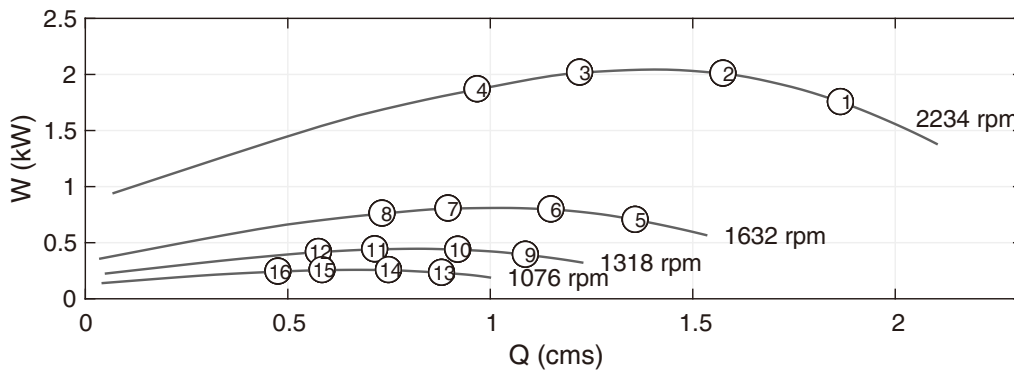
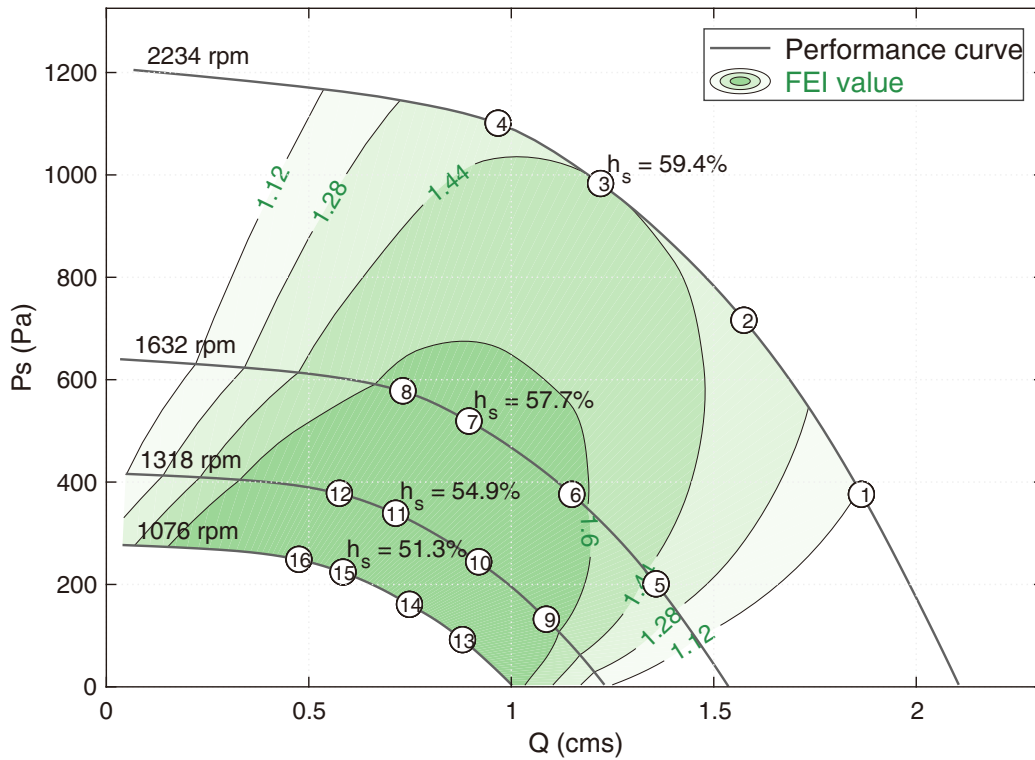

Point	Voltage(V)	Freq (Hz)	Nominal Speed(rpm)	Ps(Pa)	Q(cms)	W(kW)	Hs(%)	I(A)	LwA
1	400	50	2233	375	1.866	1.75	39.9	2.63	89
2	400	50	2234	715	1.576	2.01	56.0	2.98	86
3	400	50	2234	982	1.222	2.02	59.4	2.98	87
4	400	50	2232	1100	0.969	1.87	56.9	2.77	92
5	400	50	1631	200	1.359	0.70	38.7	1.29	81
6	400	50	1632	375	1.151	0.80	54.1	1.38	78
7	400	50	1632	518	0.897	0.80	57.7	1.38	78
8	400	50	1633	577	0.734	0.76	55.7	1.33	80
9	400	50	1318	131	1.088	0.39	36.4	0.88	77
10	400	50	1318	243	0.921	0.44	51.3	0.95	74
11	400	50	1318	338	0.716	0.44	54.9	0.97	73
12	400	50	1318	377	0.577	0.41	52.2	0.94	74
13	400	50	1077	91	0.881	0.23	34.5	0.65	71
14	400	50	1076	160	0.750	0.26	47.2	0.70	68
15	400	50	1076	223	0.586	0.26	51.3	0.70	67
16	400	50	1076	248	0.477	0.24	48.9	0.67	68

Speed (RPM) shown is nominal.  
 Performance is based on actual speed of test.  
 Ps is static pressure, Q is airflow, W is power input measured, Hs is fan static efficiency, A is input current, LwO(A) is A-weighted sound power.  
 Performance certified is for installation type A-Free Inlet, Free Outlet.  
 Performance ratings do not include the effects of appurtenances (accessories).  
 FEIs values are calculated in accordance with ANSI/AMCA Standard 208 and are based on wire-to-air measurement, AMCA 211 ratings.  
 FEIs values for fans with specific motors will vary slightly from those shown.  
 The A-weighted sound ratings shown have been calculated per AMCA International Standard 301.  
 Values shown are for outlet Lwo A sound power levels for installation type A-Free Inlet, Free Outlet.  
 EC Motor Model Number EC112D-L1HL03.

# Characteristic Curve (eBNC 450-LP W3)

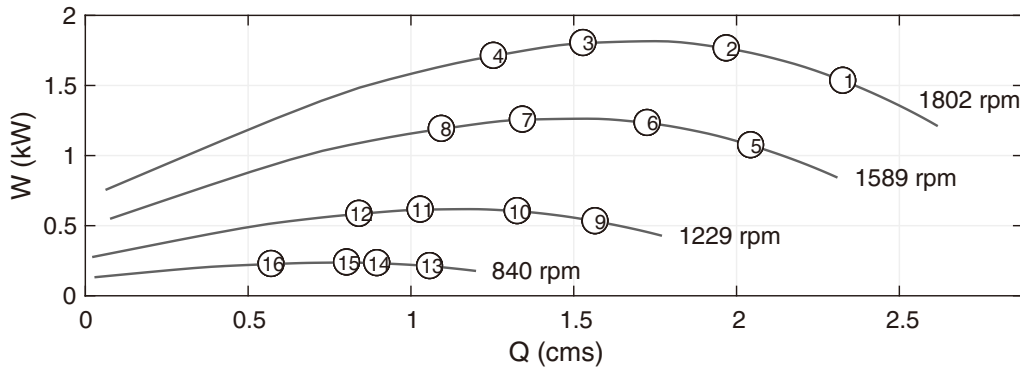
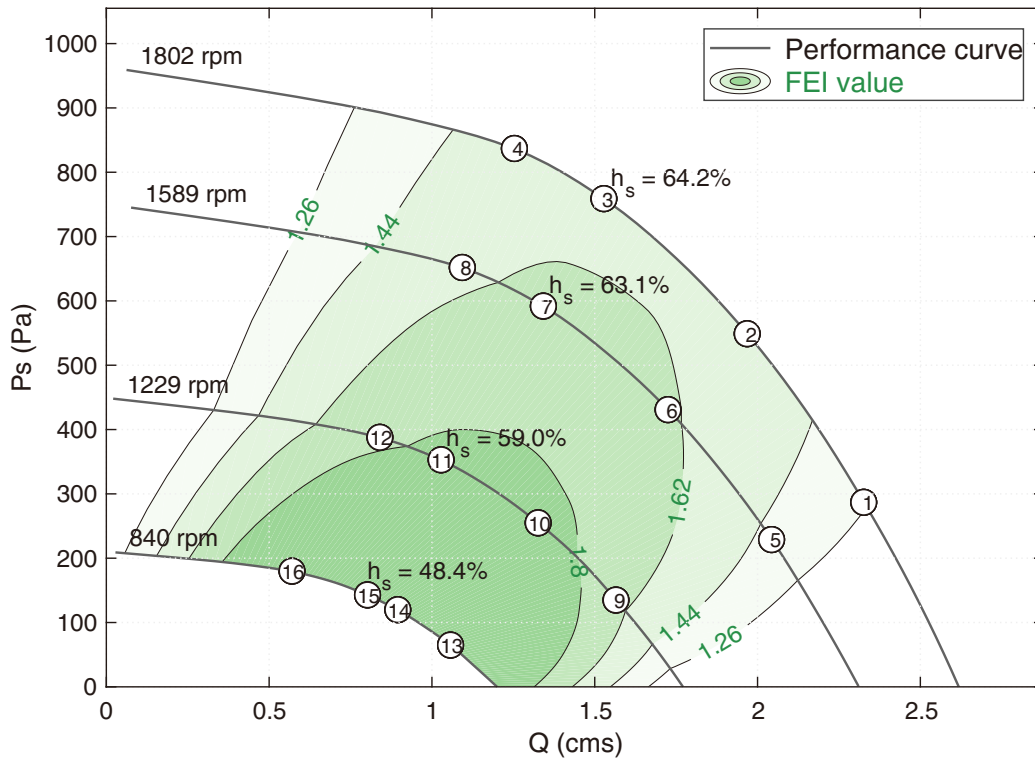

Point	Voltage(V)	Freq (Hz)	Nominal Speed(rpm)	Ps(Pa)	Q(cms)	W(kW)	Hs(%)	I(A)	LwA
1	380	50	1802	286	2.328	1.53	43.4	2.56	87
2	380	50	1802	548	1.970	1.76	61.0	2.92	84
3	380	50	1802	758	1.530	1.80	64.2	2.96	83
4	380	50	1802	836	1.255	1.71	61.2	2.82	86
5	380	50	1588	228	2.040	1.073	43.3	1.86	84
6	380	50	1589	430	1.727	1.23	60.2	2.08	82
7	380	50	1589	591	1.344	1.26	63.1	2.14	82
8	380	50	1589	651	1.095	1.19	59.8	2.05	83
9	380	50	1229	134	1.567	0.53	39.6	0.99	77
10	380	50	1229	254	1.328	0.60	56.0	1.10	75
11	380	50	1229	352	1.030	0.61	59.0	1.12	74
12	380	50	1229	387	0.842	0.58	55.8	1.07	76
13	380	50	840	64	1.059	0.21	32.0	0.43	70
14	380	50	840	119	0.897	0.23	45.9	0.46	68
15	380	50	840	142	0.804	0.24	48.4	0.47	67
16	380	50	840	179	0.572	0.23	45.3	0.46	67

Speed (RPM) shown is nominal.  
 Performance is based on actual speed of test.  
 Ps is static pressure, Q is airflow, W is power input measured, Hs is fan static efficiency, A is input current, LwO(A) is A-weighted sound power.  
 Performance certified is for installation type A-Free Inlet, Free Outlet.  
 Performance ratings do not include the effects of appurtenances (accessories).  
 FEIs values are calculated in accordance with ANSI/AMCA Standard 208 and are based on wire-to-air measurement, AMCA 211 ratings.  
 FEIs values for fans with specific motors will vary slightly from those shown.  
 The A-weighted sound ratings shown have been calculated per AMCA International Standard 301.  
 Values shown are for outlet Lwo A sound power levels for installation type A-Free Inlet, Free Outlet.  
 EC Motor Model Number EM13210A412A4.

# Characteristic Curve (eBNC 500-LP W3)

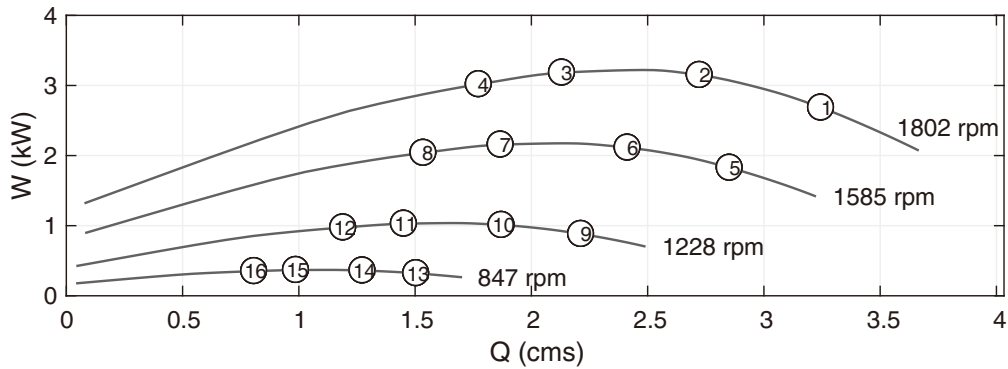
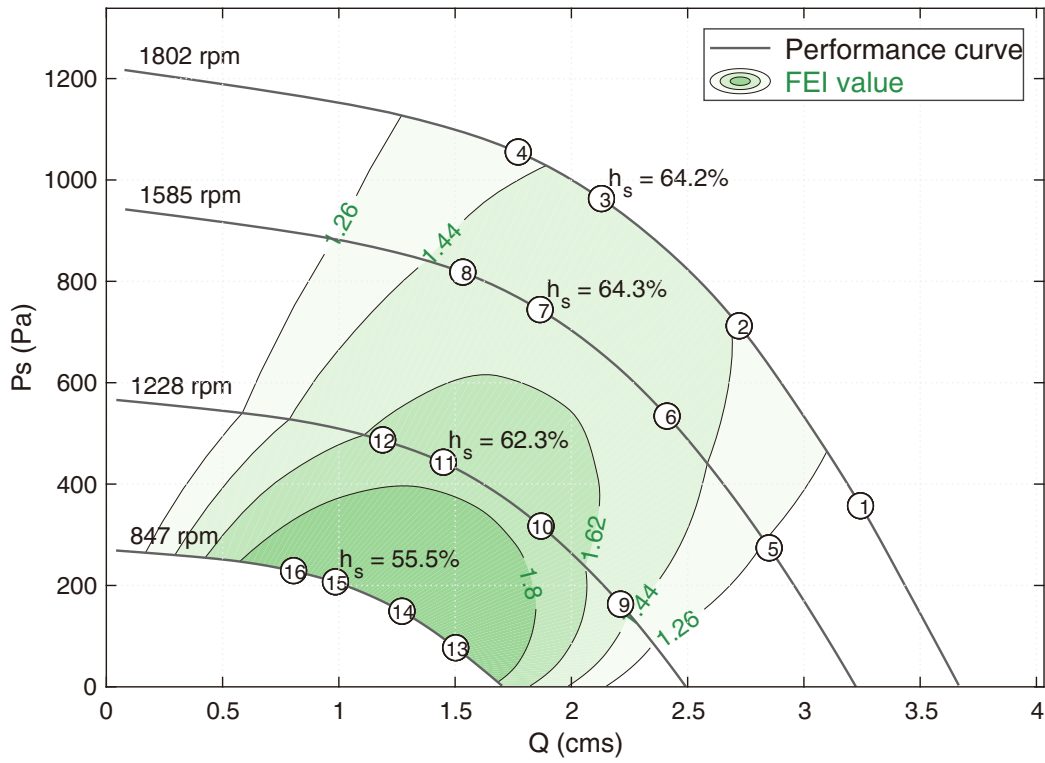

Point	Voltage(V)	Freq (Hz)	Nominal Speed(rpm)	Ps(Pa)	Q(cms)	W(kW)	Hs(%)	I(A)	LwA
1	380	50	1802	356	3.246	2.68	43.0	4.36	94
2	380	50	1802	711	2.724	3.15	61.3	5.19	89
3	380	50	1802	962	2.132	3.18	64.2	5.20	89
4	380	50	1802	1054	1.774	3.01	61.8	4.92	92
5	380	50	1585	273	2.853	1.83	42.6	3.02	90
6	380	50	1585	533	2.414	2.11	60.7	3.48	86
7	380	50	1585	743	1.868	2.16	64.3	3.54	85
8	380	50	1585	817	1.536	2.04	61.4	3.36	87
9	380	50	1228	162	2.214	0.88	40.7	1.53	84
10	380	50	1228	316	1.872	1.01	58.5	1.76	80
11	380	50	1228	442	1.452	1.03	62.3	1.81	79
12	380	50	1228	486	1.191	0.97	59.3	1.70	80
13	380	50	847	76	1.505	0.32	35.7	0.62	77
14	380	50	847	148	1.274	0.36	55.3	0.69	75
15	380	50	847	206	0.988	0.37	55.5	0.71	73
16	380	50	847	228	0.808	0.35	52.6	0.68	72

Speed (RPM) shown is nominal.  
 Performance is based on actual speed of test.  
 Ps is static pressure, Q is airflow, W is power input measured, Hs is fan static efficiency, A is input current, LwO(A) is A-weighted sound power.  
 Performance certified is for installation type A-Free Inlet, Free Outlet.  
 Performance ratings do not include the effects of appurtenances (accessories).  
 FEIs values are calculated in accordance with ANSI/AMCA Standard 208 and are based on wire-to-air measurement, AMCA 211 ratings.  
 FEIs values for fans with specific motors will vary slightly from those shown.  
 The A-weighted sound ratings shown have been calculated per AMCA International Standard 301.  
 Values shown are for outlet Lwo A sound power levels for installation type A-Free Inlet, Free Outlet.  
 EC Motor Model Number EM13210A412A4.

# Characteristic Curve (eBNC 560-LP W5)

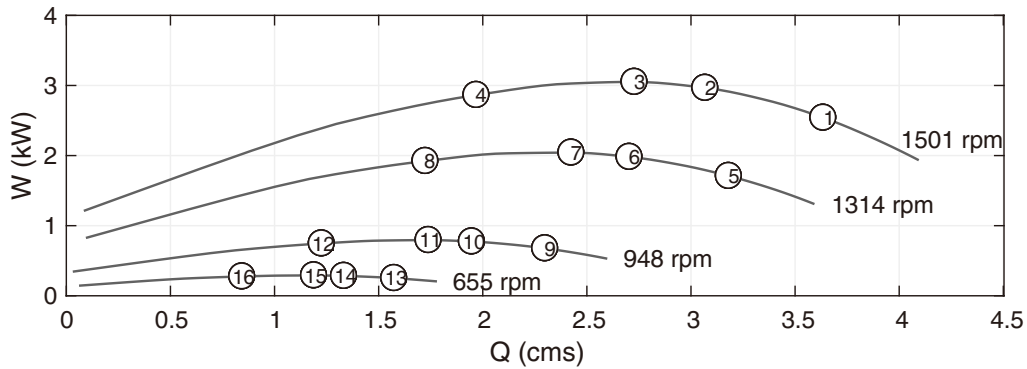
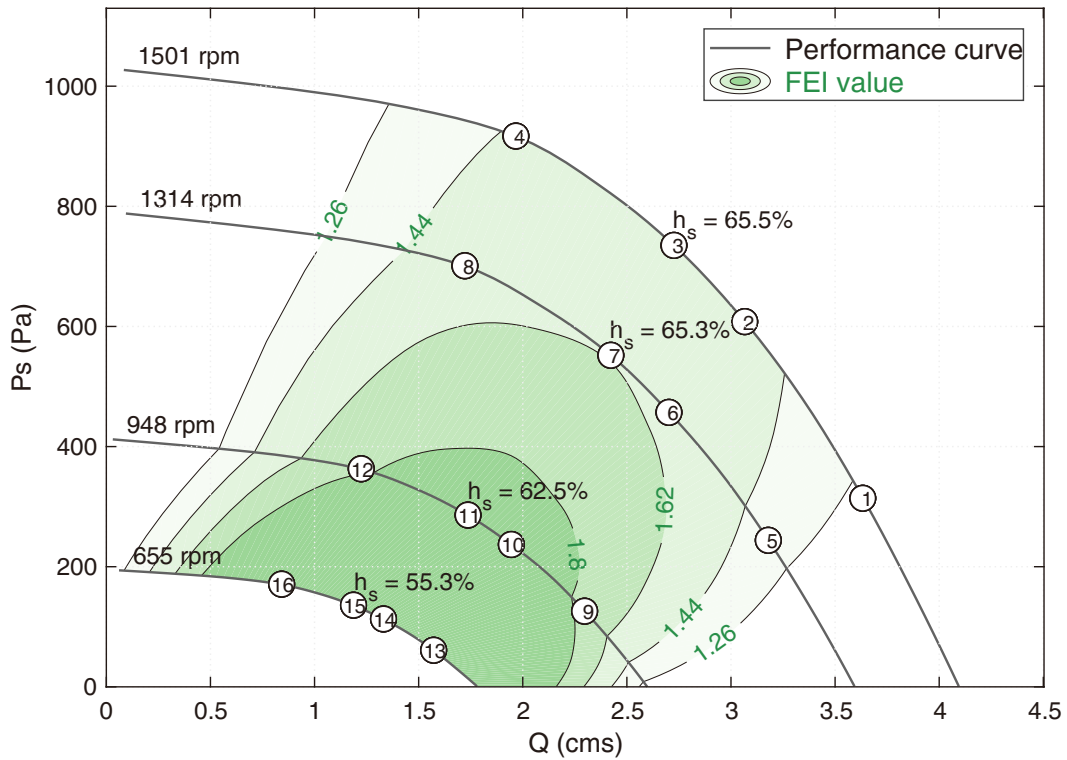

Point	Voltage(V)	Freq (Hz)	Nominal Speed(rpm)	Ps(Pa)	Q(cms)	W(kW)	Hs(%)	I(A)	LwA
1	380	50	1501	313	3.636	2.54	44.8	4.17	90
2	380	50	1501	607	3.069	2.97	62.7	4.95	87
3	380	50	1501	734	2.729	3.05	65.5	5.08	87
4	380	50	1501	916	1.970	2.86	62.8	4.72	89
5	380	50	1314	243	3.182	1.71	45.2	2.89	86
6	380	50	1314	456	2.705	1.98	62.2	3.30	82
7	380	50	1314	551	2.426	2.04	65.3	3.41	82
8	380	50	1314	700	1.725	1.92	62.7	3.08	86
9	380	50	948	125	2.300	0.68	42.5	1.19	77
10	380	50	948	236	1.948	0.77	59.5	1.35	74
11	380	50	948	285	1.740	0.79	62.5	1.39	74
12	380	50	948	362	1.227	0.74	59.5	1.31	76
13	380	50	655	60	1.575	0.25	37.4	0.50	69
14	380	50	655	112	1.334	0.28	52.5	0.54	67
15	380	50	655	135	1.190	0.29	55.3	0.56	67
16	380	50	655	170	0.845	0.27	52.2	0.54	67

Speed (RPM) shown is nominal.  
 Performance is based on actual speed of test.  
 Ps is static pressure, Q is airflow, W is power input measured, Hs is fan static efficiency, A is input current, LwO(A) is A-weighted sound power.  
 Performance certified is for installation type A-Free Inlet, Free Outlet.  
 Performance ratings do not include the effects of appurtenances (accessories).  
 FEIs values are calculated in accordance with ANSI/AMCA Standard 208 and are based on wire-to-air measurement, AMCA 211 ratings.  
 FEIs values for fans with specific motors will vary slightly from those shown.  
 The A-weighted sound ratings shown have been calculated per AMCA International Standard 301.  
 Values shown are for outlet Lwo A sound power levels for installation type A-Free Inlet, Free Outlet.  
 EC Motor Model Number EM13210A412B2.

# Characteristic Curve (eBNC 630-LP W5)

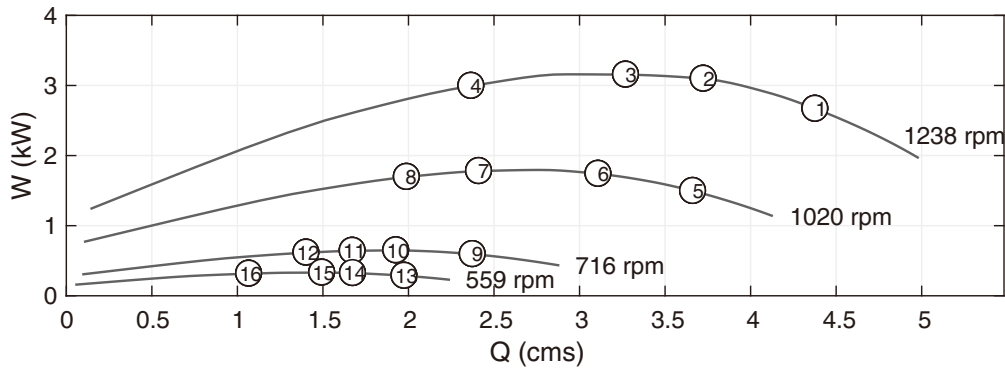
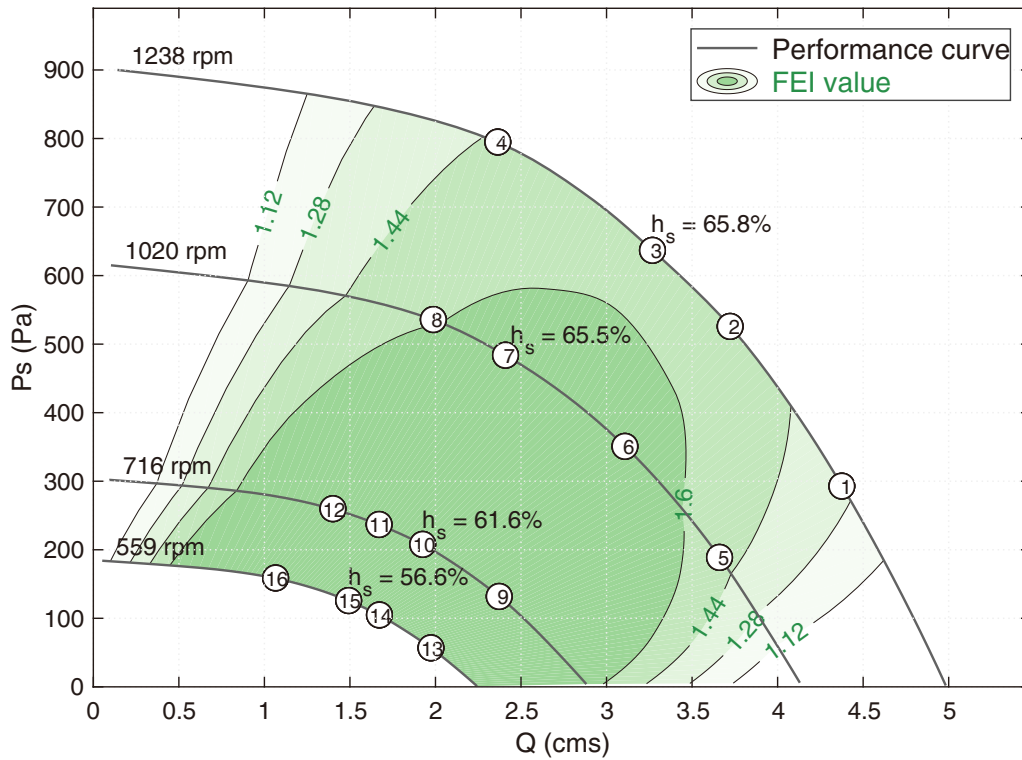

Point	Voltage(V)	Freq (Hz)	Nominal Speed(rpm)	Ps(Pa)	Q(cms)	W(kW)	Hs(%)	I(A)	LwA
1	380	50	1238	292	4.379	2.67	47.9	4.42	89
2	380	50	1238	525	3.726	3.10	63.1	5.26	86
3	380	50	1234	636	3.272	3.15	65.8	5.35	85
4	380	50	1238	794	2.368	2.99	62.7	5.01	86
5	380	50	1020	188	3.664	1.49	46.1	2.44	85
6	380	50	1020	350	3.111	1.74	62.5	2.83	81
7	380	50	1020	483	2.413	1.78	65.5	2.90	81
8	380	50	1020	535	1.991	1.70	62.8	2.76	83
9	380	50	716	131	2.376	0.59	52.6	1.06	76
10	380	50	715	207	1.929	0.65	61.6	1.16	73
11	380	50	716	236	1.674	0.64	61.6	1.14	73
12	380	50	716	259	1.404	0.61	59.1	1.10	74
13	380	50	559	56	1.977	0.28	38.5	0.55	72
14	380	50	559	81	1.830	0.31	48.2	0.59	69
15	380	50	559	125	1.496	0.33	56.6	0.63	68
16	380	50	559	158	1.069	0.31	53.5	0.61	66

Speed (RPM) shown is nominal.  
 Performance is based on actual speed of test.  
 Ps is static pressure, Q is airflow, W is power input measured, Hs is fan static efficiency, A is input current, LwO(A) is A-weighted sound power.  
 Performance certified is for installation type A-Free Inlet, Free Outlet.  
 Performance ratings do not include the effects of appurtenances (accessories).  
 FEIs values are calculated in accordance with ANSI/AMCA Standard 208 and are based on wire-to-air measurement, AMCA 211 ratings.  
 FEIs values for fans with specific motors will vary slightly from those shown.  
 The A-weighted sound ratings shown have been calculated per AMCA International Standard 301.  
 Values shown are for outlet Lwo A sound power levels for installation type A-Free Inlet, Free Outlet.  
 EC Motor Model Number EM13210A412B2.



## Tender Specifications Data Sheet

Technical Data	Result	Unit
Fan Type/Model		
Airflow		cms
Static Pressure		Pa
Stat Overall Efficiency, Ps %		%
Operating Speed, n		rpm
Motor Type	EC Motor	
Type of Control	10-100% Speed Control	
Motor Efficiency Class	IE4	
Total Power Input (kW)		kW
Specific Fan Power (w/cms)		w/cms
Nominal Voltage Range (V)	380-480	V
Line Frequency	50/60	Hz
Nominal Current		A
Degree of Protection (IP)		
Sound Power Level, Lin (Lw0/Lwi)		dB
Sound Power Level, Lw0 (A)		dB (A)
Sound Pressure Level (Lp0 (A)@1.5m)		dB (A)
Permissible Amb Temperature		°C
Weight of Fan		kg

# Power and Control Wiring

The following section shows the terminal layouts and wiring method for eBNC Ecowatt plug fans. eBNC fan has various speed control functions are available as follows:

1. Manual speed control by using of Potentiometer: Analog signal 0–10Vdc.
2. Automatic speed control by using of Demand Controlled Ventilation (DCV) or Building Management System (BMS): Analog signal 0–10Vdc or 4–20mA.
3. Automatic speed control by using of eBNC Modbus RTU interface PC program: RS485 digital port.

Please contact Kruger to get a training about eBNC Modbus RTU interface PC program and configurations method.

## Power Wiring

- ➔ Use the appropriate cable size for each motor model by referring to power wiring section.
- ➔ Shielded cables are not required for use on power cables.
- ➔ Where multiple fans are installed in one AHU, individual circuit breakers must be installed for each fan.
- ➔ Three-phase main power must be connected, do not use the output from a variable speed drive to power an eBNC Ecowatt plenum fan.

## Control Wiring

- ➔ Ensure that the RSA, RSB, 0-10V input, +10V output and ground of each fan are accessible at an external location away from the three phase power supply connections.
- ➔ Where MODBUS over RS485 is used, appropriate shielded cables should be used.



# Ecowatt eBNC 315, 355 & 400

Three-phase fan eBNC 315, 355 & 400 wiring Diagram consists of 2 parts: power and control wiring terminals are shown in Fig. 1.



Fig. 1. eBNC 315, 355 & 400 Wiring Diagram

Color	Wiring	Function	Description
Brown	Control	485A	RS485 data +, 485 communication interface
Black	Control	485B	RS485 data -, 485 communication interface
Green	Control	24V	24Vdc output
White	Control	FG	Speed output 2 pulses per revolution
Red	Control	10V	10Vdc, 10mA max
Yellow	Control	VSP/PWM	Analog Input 0-10V or 4-20mA
Blue	Control	GND	Signal ground
Brown	Power	L1(R)	Power input phase1
Blue	Power	L2(S)	Power input phase2
Black	Power	L3(T)	Power input phase3
Yellow/Green	Power	PE	Protective Earth
Orange	Relay	NO	Output relay N.O. contact
Gray	Relay	COM	Output relay common contact
Red	Relay	NC	Output relay N.C. contact

Noted: There are 2 spec of wire harness length (1.2m for Single fan and 3.5m for Multi fan)

## Power Wiring

- ➔ Power wiring (L1, L2 and L3) connections to the 3PH 380V 50/60Hz power supply (R, S, T).
- ➔ PE wire is the protective earth terminal like below diagram.
- ➔ Use AWG16 or bigger for L1, L2, L3 and PE.

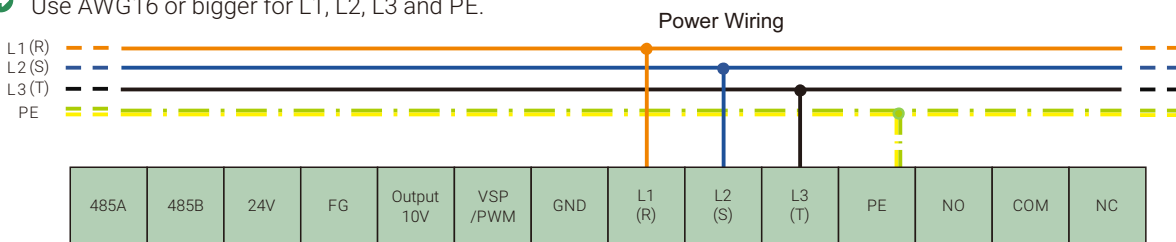

## Status Relay

- ➔ Status relay should be connected to show the status of Fan motor operation.
- ➔ When normal operation the **NC**-**COM** will be short circuit.
- ➔ When fan faults as below conditions, **NO**-**COM** will be short circuit.
  - Motor Overheat
  - Electronics Overheat
  - Locked Rotor
  - Hall Sensor Error

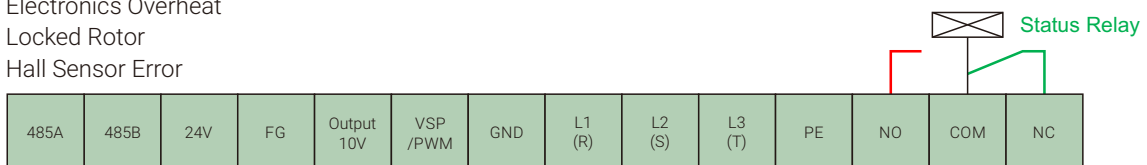

# Control Wiring

There are 3 wiring simple connection methods for control motor speed as shown below.

1. Manual speed control by using of Potentiometer: Analog signal 0–10Vdc.
2. Automatic speed control by using of Demand Controlled Ventilation (DCV) or Building Management System (BMS): Analog signal 0–10Vdc or 4–20mA.
3. Automatic speed control by using of eBNC Modbus RTU interface PC program: RS485 digital port.

Please contact Kruger to get a training about eBNC Modbus RTU interface PC program and configurations method.

## a.1 Manual speed control by using of Potentiometer (Analog signal 0-10Vdc)

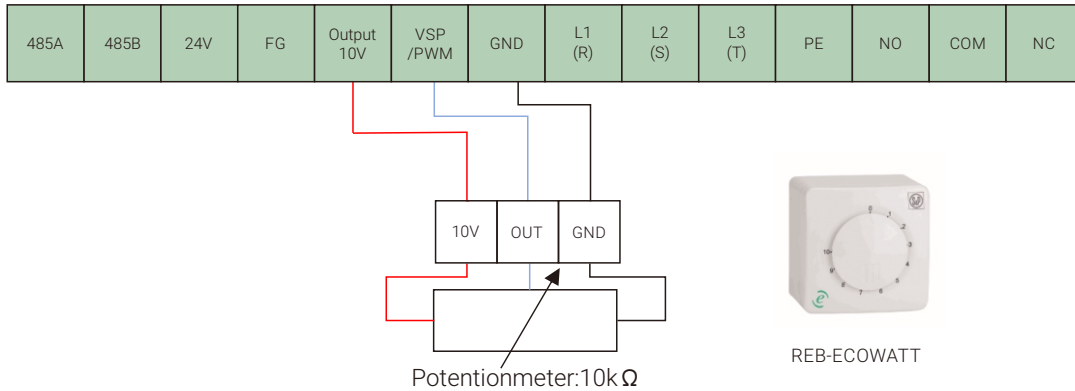

## b.1 Automatic speed control by using of DCV or BMS (Analog signal 0-10Vdc and 4-20mA)

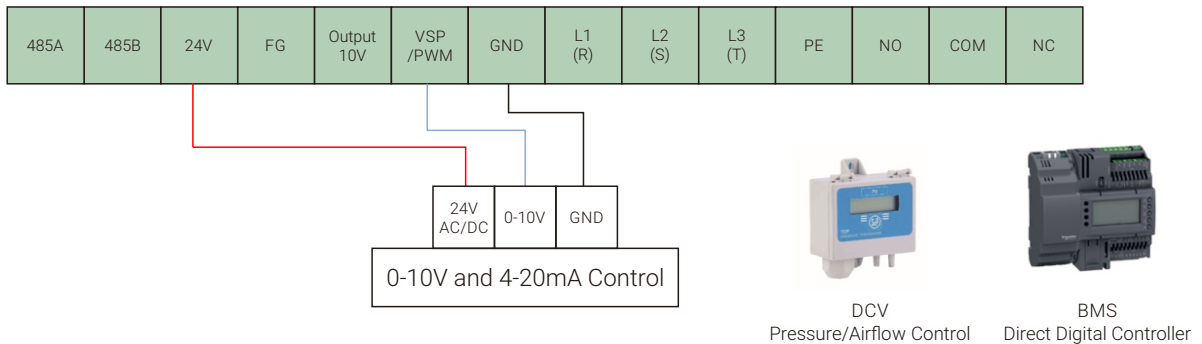

## c.1 Automatic speed control by using of Modbus RTU interface PC program (RS485 digital port)

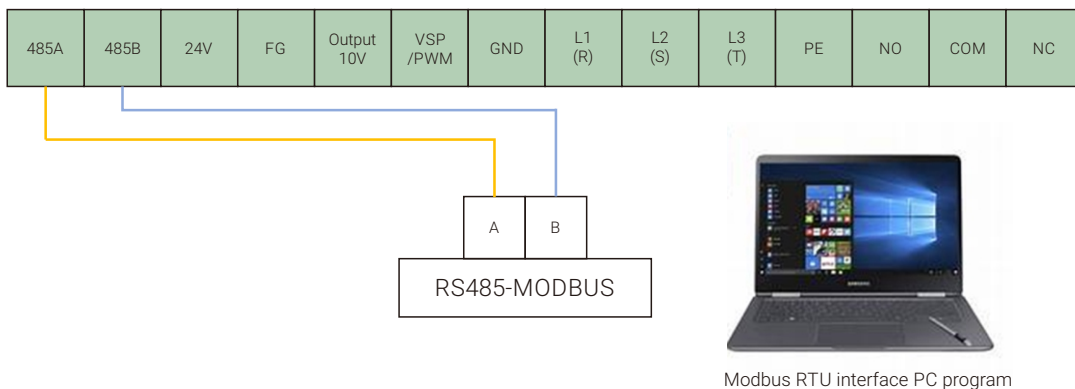

a.2 Example of Manual speed control by use Potentiometer (analog signal 0–10Vdc) for Multiple fan connection

PE L3 L2 L1  
(T) (S) (R)

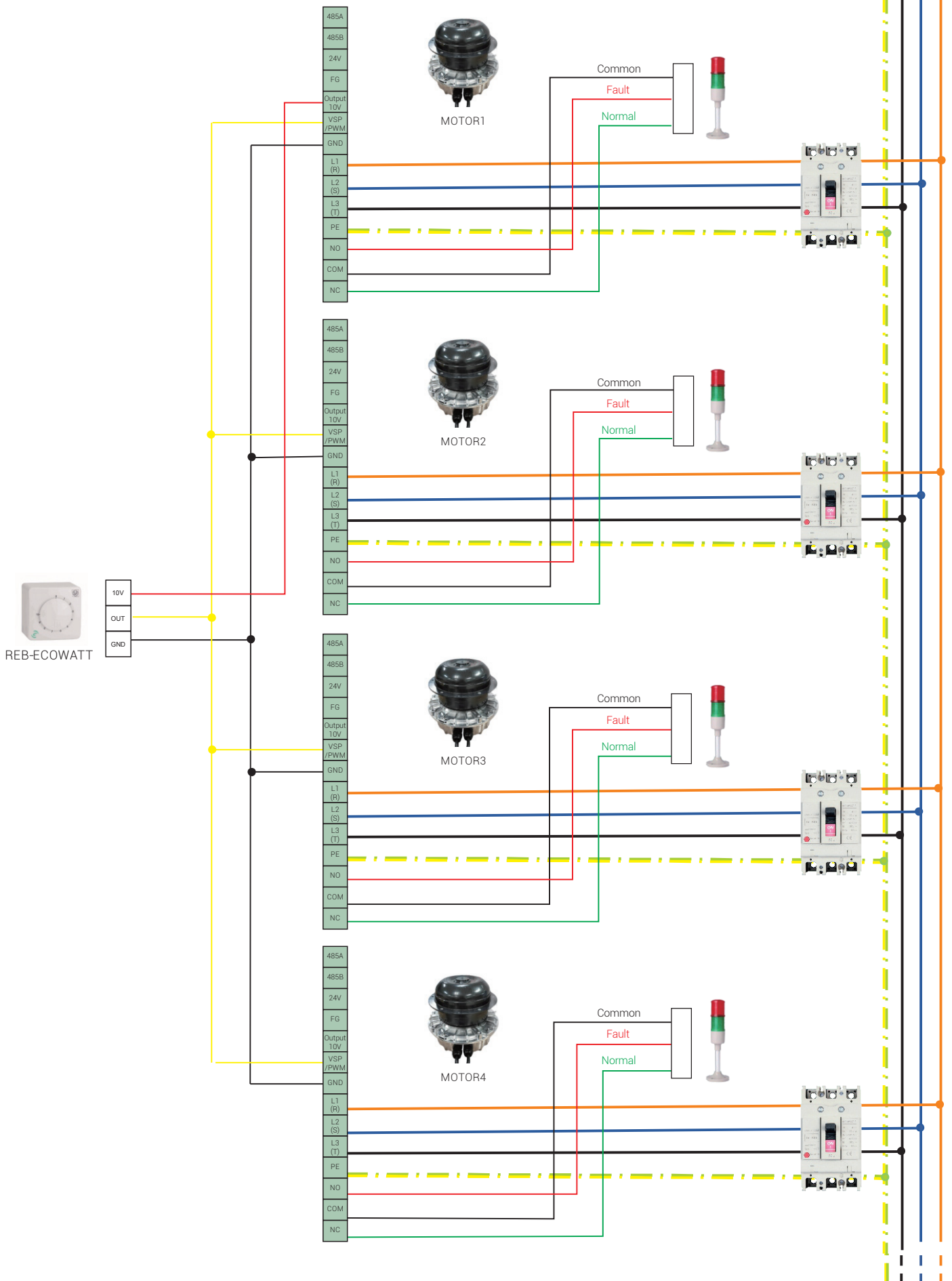

b.2 Example of Automatic speed control by use Demand Controlled Ventilation (DCV) or Building Management System (BMS) via analog signal 0–10Vdc or 4–20mA for Multiple fan connection

L3 (T) L2 (S) L1 (R)  
PE

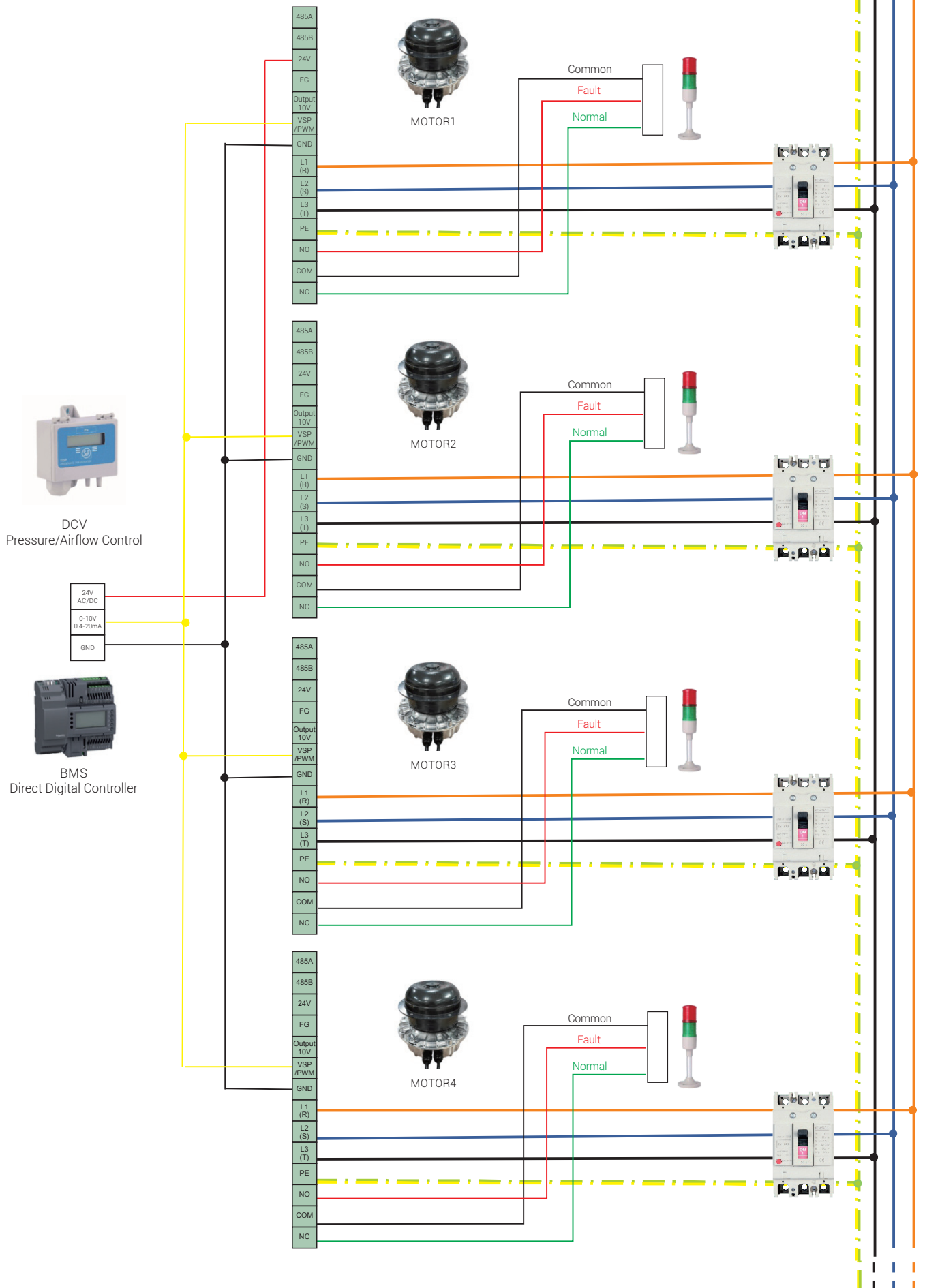

c.2 Example of Automatic speed control by use eBNC Modbus RTU interface PC program via RS485 digital port for Multiple fan connection

PE L3 L2 L1  
(T) (S) (R)

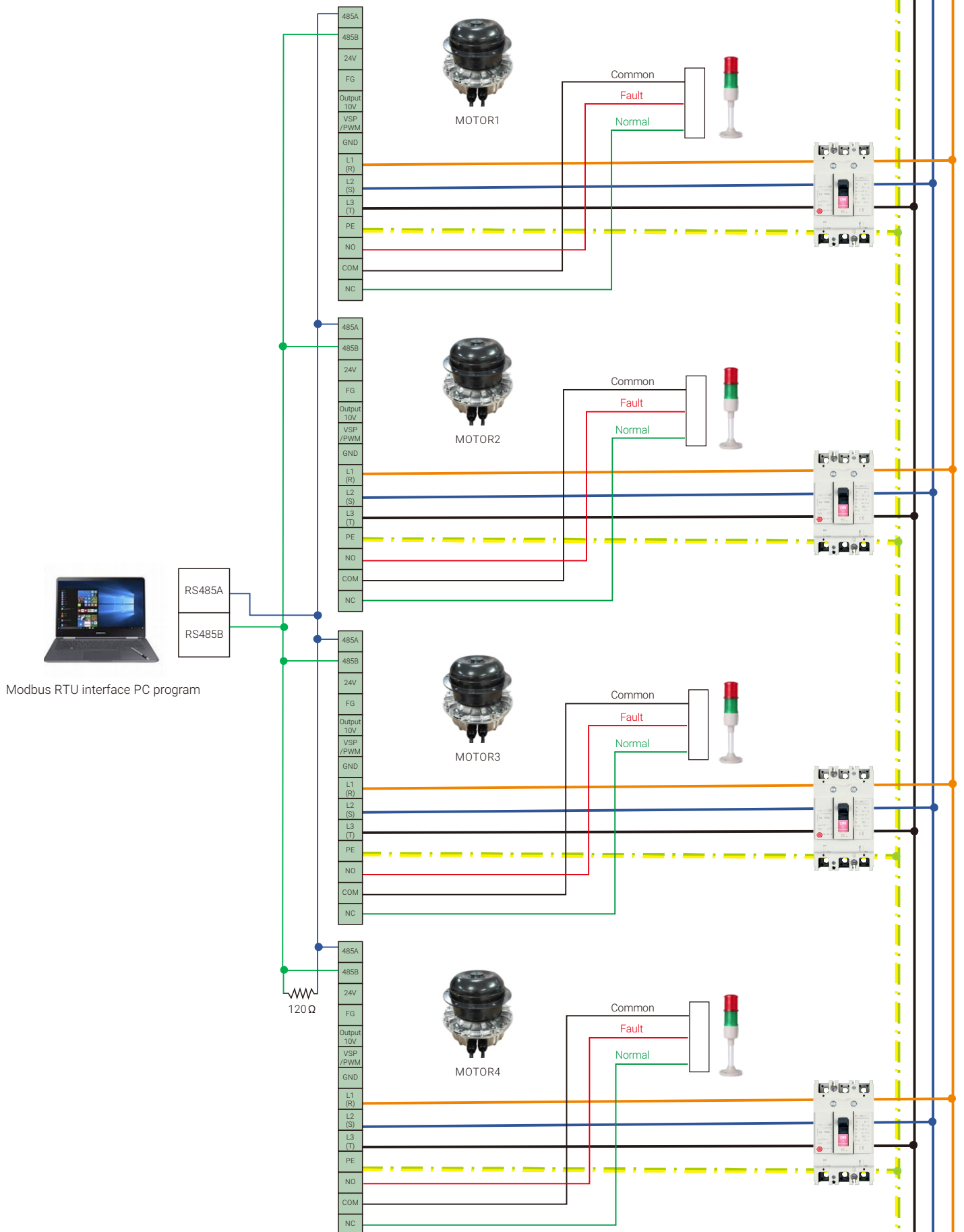

Recommends for RS485 connection  
 - To prevents an interference from electromagnetic fields, please always using the Shielded twisted pair cable.  
 - To keep the stability of the control signal, please adding 120 Ohm, 0.5W resistor at the end of control line.

## Ecowatt eBNC 450, 500, 560 & 630

Three-phase fan eBNC 450, 500, 560 & 630 wiring Diagram consists of 2 parts: power and control wiring terminals are shown in Figure.2 below.

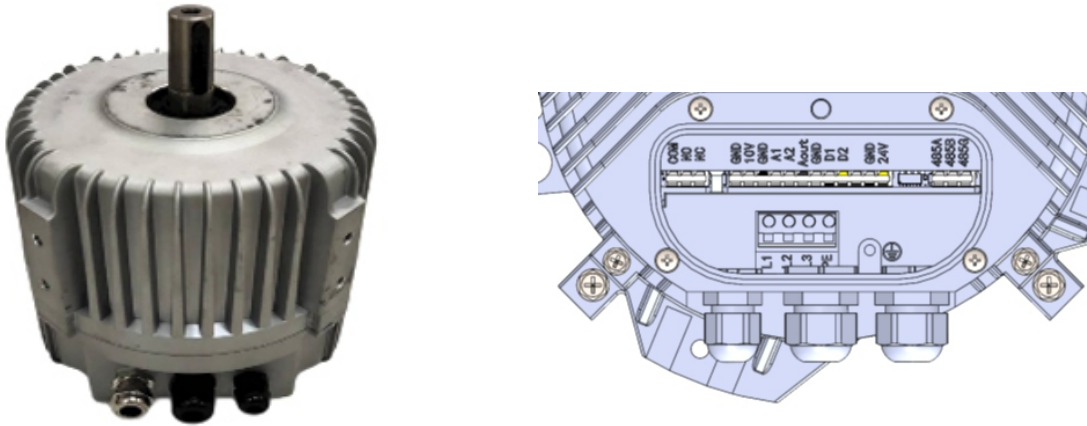

Fig. 2. eBNC 450, 500, 560 & 630 Wiring Diagram

Terminal	Wiring	Connection	Function
TL1	Power	L1(U)	Power input phase 1
	Power	L2(V)	Power input phase 2
	Power	L3(W)	Power input phase 3
	Power	PE	Protective Earth
TL2	Relay	COM	Output Relay common contact
	Relay	NO	Output relay N.O. contact
	Relay	NC	Output relay N.C. contact
TL3	Control	GND	Signal ground
	Control	10V	10Vdc, 10mA max
	Control	GND	Signal ground
	Control	A1	Analog Input 1, 0-10 V
	Control	A2	Analog Input 2, 4-20 mA
	Control	Aout	Analog Output, Programmable output
	Control	GND	Signal ground
	Control	D1	Digital Input 1, Motor start enable signal, 0V: Start Disable, 10V/24V: Start Enable
TL4	Supply	GND	Supply ground
	Supply	24V	+24 VDC supply, 50mA max
TL5	Control	485A	RS 485 data+, 485 communication interface
	Control	485B	RS 485 data-, 485 communication interface
	Control	485G	RS 485 ground, 485 communication interface



# Power Wiring

- ➔ Power wiring (L1, L2 and L3) connections to the 3PH 380V 50/60Hz power supply (R ,S, T).
- ➔ PE wire is the protective earth terminal like below diagram.
- ➔ Use AWG14 or bigger for L1, L2, L3 and PE

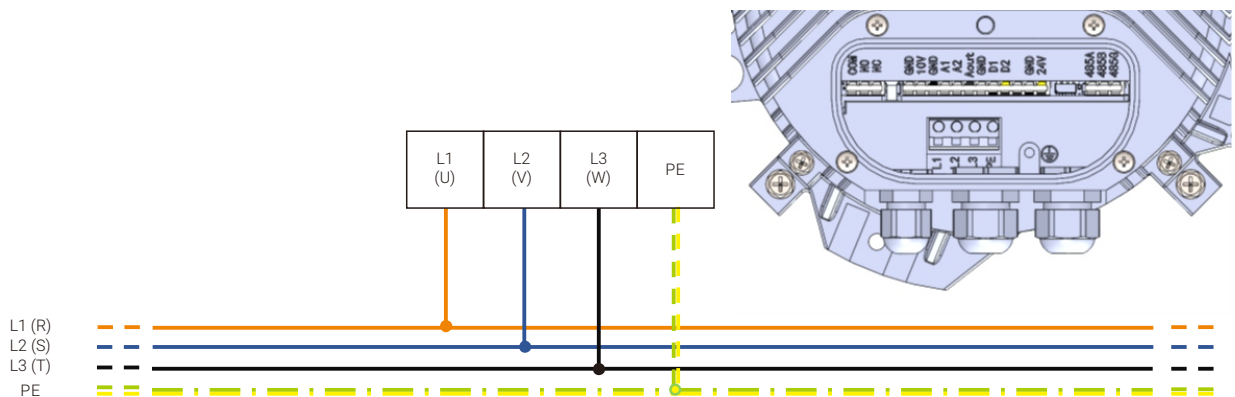
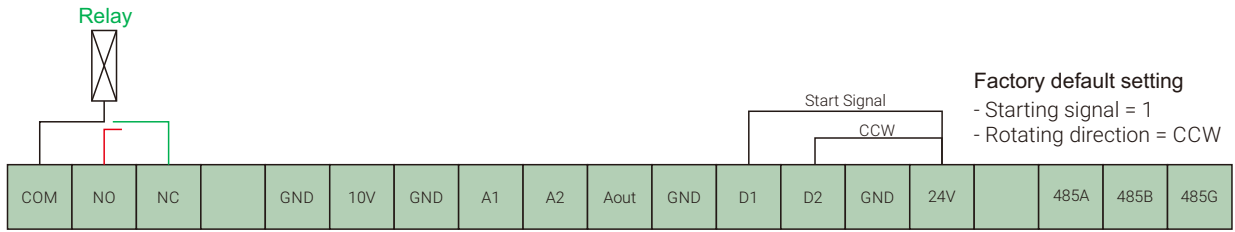

# Status Relay

- ➔ Status relay should be connected to show the status of Fan motor operation.
- ➔ When normal operation the **NC**-COM will be short circuit.
- ➔ When fan faults as below conditions, **NO**-COM will be short circuit.
  - Motor Overheat
  - Electronics Overheat
  - Locked Rotor
  - Hall Sensor Error

## Start Signal

- ➔ Start signal D1 terminal must be always connected to 24V terminal as Factory default.

## Rotating Direction Signal

- ➔ Rotating direction signal D2 terminal must be always connected to 24V terminal as Factory default.

# Control Wiring

There are 3 wiring simple connection methods for control motor speed as shown below.

1. Manual speed control by using of Potentiometer: Analog signal 0–10Vdc.
2. Automatic speed control by using of Demand Controlled Ventilation (DCV) or Building Management System (BMS): Analog signal 0–10Vdc or 4–20mA
3. Automatic speed control by using of eBNC Modbus RTU interface PC program: RS485 digital port.

Please contact Kruger to get a training about eBNC Modbus RTU interface PC program and configurations method.

## a.1 Manual speed control by using of Potentiometer (Analog signal 0-10Vdc)

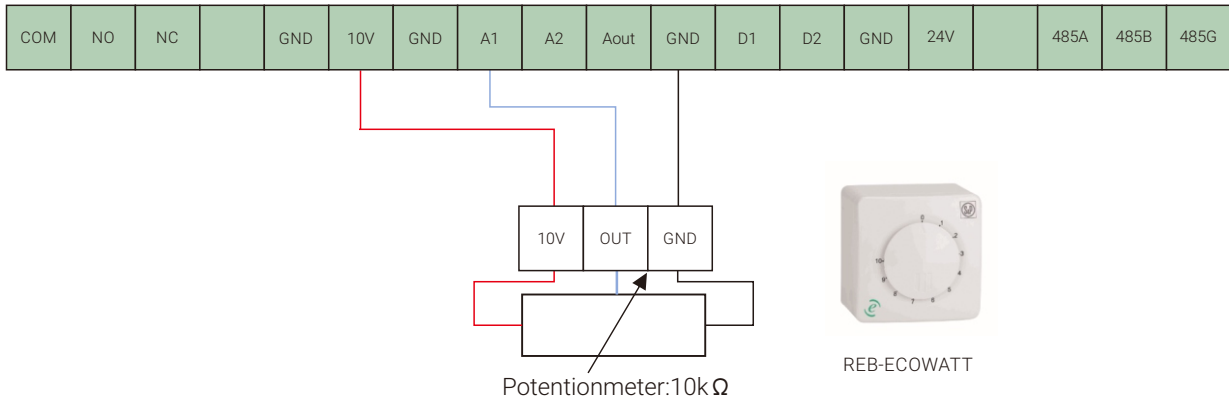

## b.1 Automatic speed control by using of DCV or BMS (Analog signal 0-10Vdc and 4-20mA)

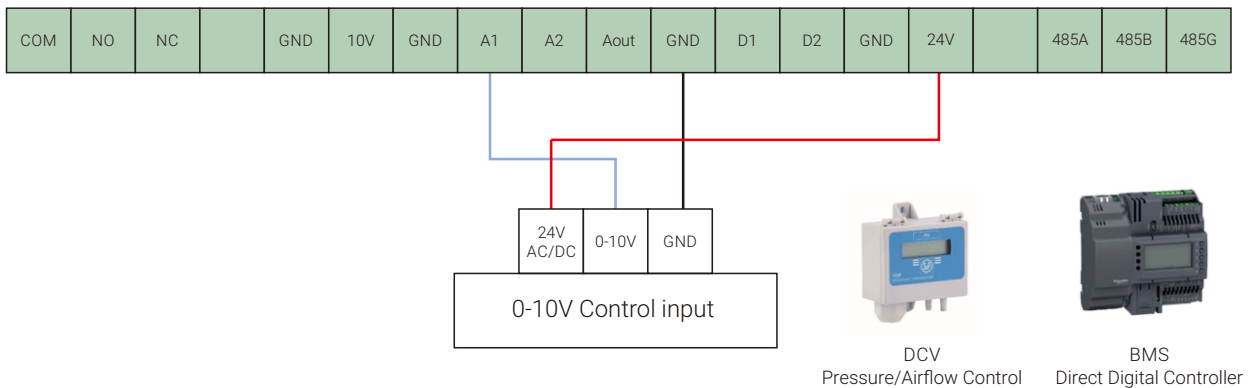

## c.1 Automatic speed control by using of Modbus RTU interface PC program (RS485 digital port)

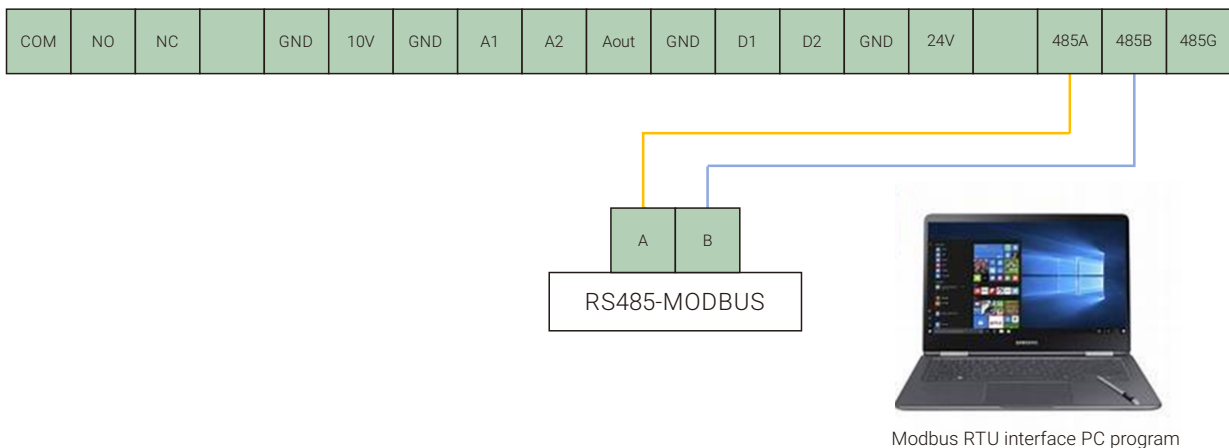

a.2 Example of Manual speed control by use of Potentiometer (analog signal 0–10Vdc) for Multiple fan connection

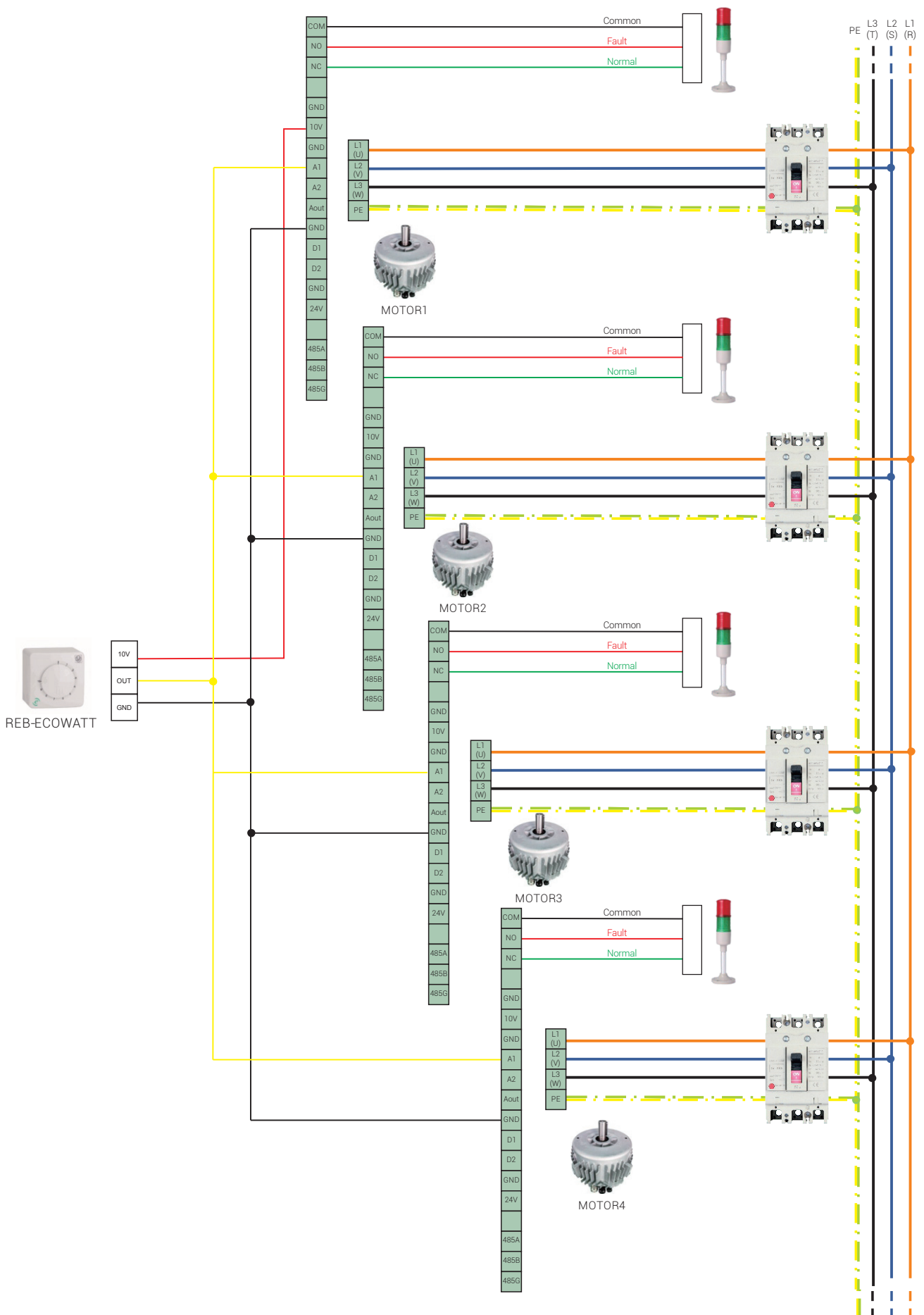

b.2 Example of Automatic speed control by use Demand Controlled Ventilation (DCV) or Building Management System (BMS) via analog signal 0–10Vdc or 4–20mA for Multiple fan connection

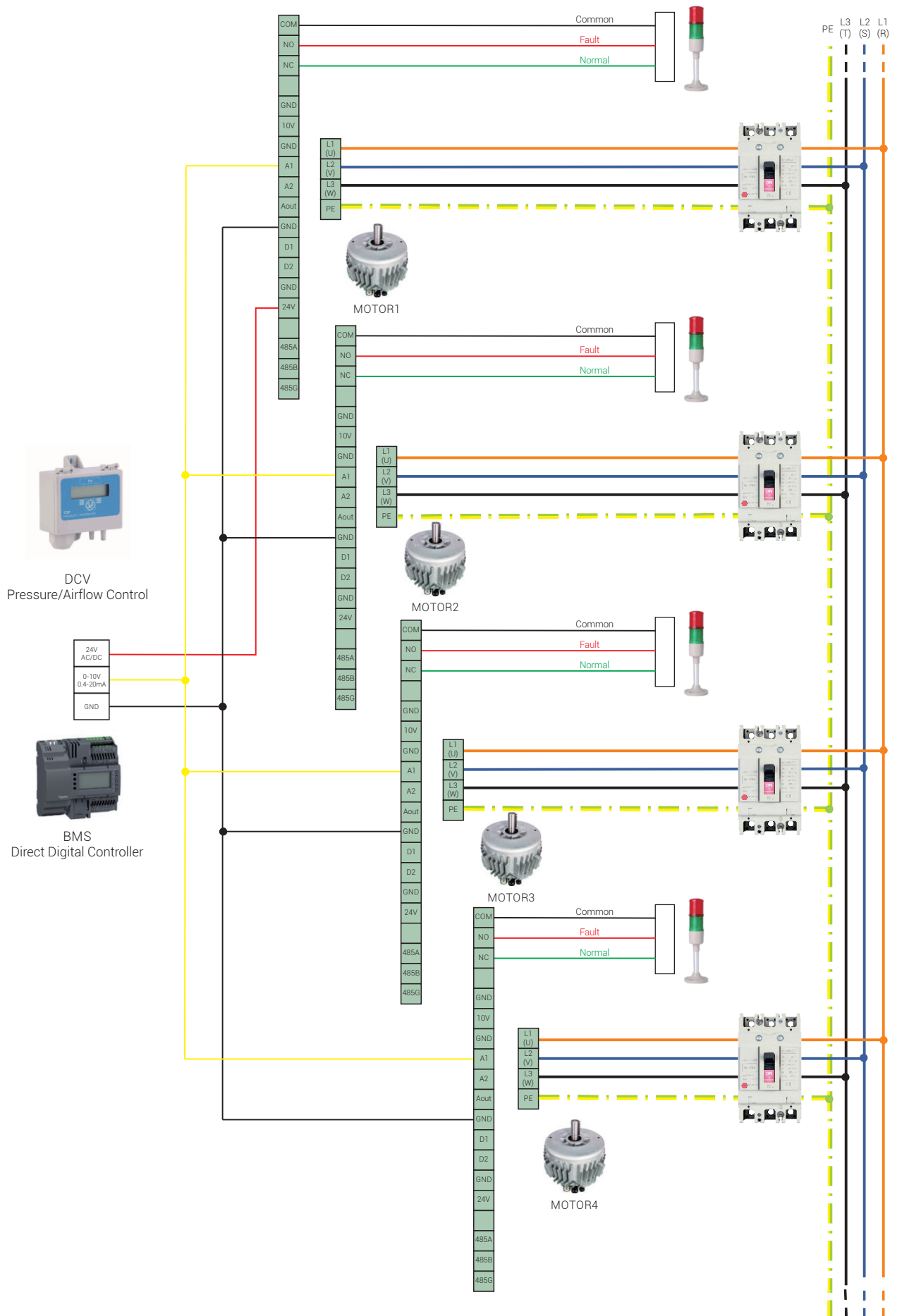

**c.2 Example of Automatic speed control by use eBNC Modbus RTU interface PC program via RS485 digital port for Multiple fan connection**

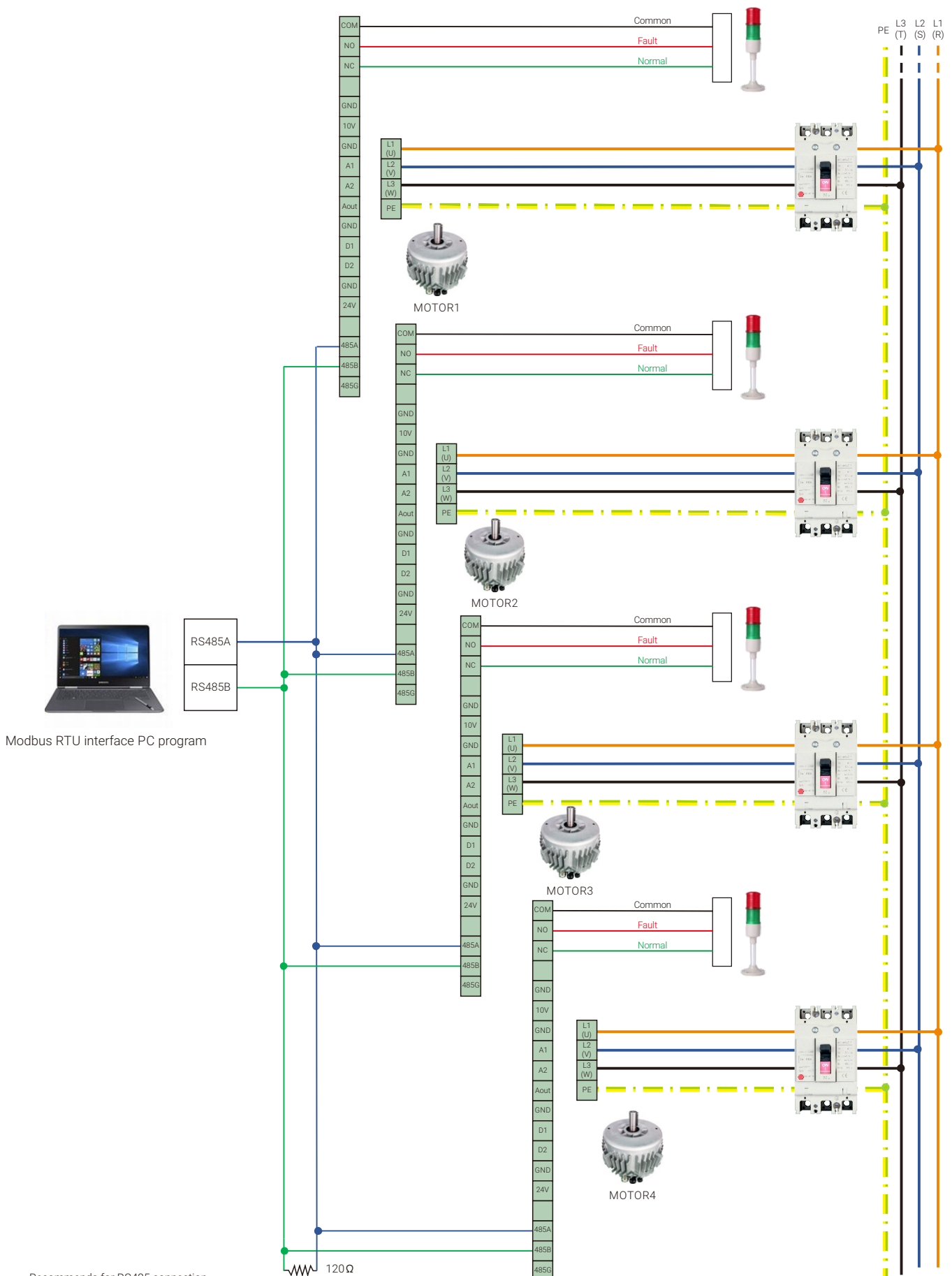

Recommends for RS485 connection  
 - To prevents an interference from electromagnetic fields, please always using the Shielded twisted pair cable.  
 - To keep the stability of the control signal, please adding 120 Ohm, 0.5W resistor at the end of control line.

## THAILAND (Regional Head Quarter)

**KRUGER VENTILATION INDUSTRIES ASIA CO. LTD.**  
30/159 Moo 1, Sinsakorn Industrial Estate, Chetsadawithi Road,  
Khok Kham Mueng, Samuthsakorn 74000, Thailand  
Tel: +662 1054298 Fax: +662 0248256-9  
Website: www.krugerfan.com

## THAILAND

**KRUGER VENTILATION IND. (THAILAND) CO. LTD.**  
30/105 Moo 1, Sinsakorn Industrial Estate, Chetsadawithi Road,  
Khok Kham Mueng, Samuthsakorn 74000, Thailand  
Tel: +662 1050399 Fax: +662 1050370-2  
Email: mktg@kruger.co.th

## INDIA

**KRUGER VENTILATION INDUSTRIES (INDIA) PVT. LTD.**  
Kruger Centre, Mumbai-Nasik Highway, Kalamgaon, Shahapur,  
Thane 421601, Maharashtra, India  
Tel: +91 9960558899/9975577211  
Email: sales@krugerindia.com

## INDIA (NORTH)

**KRUGER VENTILATION INDUSTRIES (INDIA) PVT. LTD.**  
Khasra No. 150//20/2/1, 21/1/2, 22/2, 151//16/2/2, Village Rohad,  
Tehsil Bahadurgarh, Jhajjar, Haryana-124507, India  
Tel. +91-9958991652/9958991660/8586966303  
Fax +91-1276-278096  
Email: sales.kni@krugerindia.com , service@krugerindia.com

## KOREA

**NEOMATE CO. LTD.**  
2-1010, Ace High Tech City B/D, 775 Gyeongin-ro,  
Yeongdeungpo-gu, Seoul, Korea. Postal Code 07299  
Tel: +82-2-2679-2052 Fax: +82-2-2679-2174  
Email: y7890@neomate.co.kr

## SINGAPORE

**KRUGER ENGINEERING PTE. LTD.**  
2 Venture Drive #20-23, Vision Exchange,  
Singapore 608526.  
Tel: +65 68631191 Fax: +65 68631151  
Email: mktg@krugerfan.com

## AUSTRALIA

**S&P KRUGER AUSTRALIA PTY. LTD.**  
2 Cunningham St, Moorebank N.S.W. 2170  
Tel: +61 2-98227747  
Fax: +61 2-98227757  
Email: info@sandpkruger.com.au

## INDONESIA

**P. T. KRUGER VENTILATION INDONESIA.**  
JL. Teuku Umar No.20,  
Karawaci - Tangerang 15115, Indonesia  
Tel: +62 21-5512288/5513557 Fax: +62 21-5513502  
Email: mktg@krugerindo.co.id

## VIETNAM

**KRUGER VENTILATION INDUSTRIES (VIETNAM) CO. LTD.**  
Lot A7. 2-4, C2 Road, Thanh Thanh Cong IZ,  
Trang Bang Dist. Tay Ninh Province, Vietnam  
Tel: +84-276 3585200/01/02 Fax: +84-276 3585199  
Email: mktg@krugervn.com

## CHINA (GUANGZHOU)

**GUANGZHOU KRUGER VENTILATION CO. LTD.**  
No. 9 Huahui Road, Huashan, Huadu,  
Guangzhou, P.R. China 510880  
Tel: +86 20-66356635 Fax: +86 20-86786001/86786500  
Email: gzkru@krugergz.com

## CHINA (TIANJIN)

**TIANJIN KRUGER VENTILATION CO. LTD.**  
Jingjin Science and Technology Park  
Wuqing District, Tianjin, China  
Tel: +86 22-22143480/3481 Fax: +86 22-22143482  
Email: krugertj@krugertj.com

## CHINA (SHANGHAI)

**SHANGHAI KRUGER VENTILATION CO., LTD.**  
No.500 Yuanguo Road, Anting, Jiading District,  
Shanghai 201814, P.R. China  
Tel: +86 21-69573266 Fax: +86 21-69573296  
Email: shkruger@krugarchina.com

## CHINA (WUHAN)

**WUHAN KRUGER VENTILATION CO. LTD.**  
No. 805, Huian Ave, Dongxihu District, Wuhan,  
Hubei, P.R. China 430040  
Tel: +86 27- 83248840/83060522/83097505  
Fax: +86 27- 83261886  
Email: whkruger@krugerwh.com

## HONG KONG

**KRUGER VENTILATION (HONG KONG) LIMITED.**  
Flat C, 9/F, Yeung Yiu Chung (No.8) Industrial Building,  
20 Wang Hoi Road, Kowloon Bay, Kowloon, Hong Kong  
Tel: +852 22469182 Fax: +852 22469187  
Email: info@kruger.com.hk

## TAIPEI

**KRUGER VENTILATION (TAIWAN) CO., LTD.**  
No. 157, Ping-an Rd, Hengfeng Village, Dayuan Shiang  
Taoyuan County 337, Taiwan  
Tel: +886 3-3859119 Fax: +886 3-3859118  
Email: sales@krugertwn.com.tw

## MALAYSIA

**KRUVENT INDUSTRIES (M) SDN. BHD.**  
Lot 850, Jalan Subang 7, Taman Perindustrian Subang,  
47500, Subang Jaya, Selangor D.E.  
Tel: +603 80743399 Fax: +603 80743388  
Email: mktg@kruger.com.my

## PHILIPPINES

**KRUGER M & E INDUSTRIES CORPORATION**  
B3 Welborne Industrial Park Bancal Carmona Cavite  
4116, Philippines  
Tel: +63-2-7 6223260 \* +63-46 4129652  
HP: +63 925 8018444  
Email: mktg@krugerph.net



**KRUVENT INDUSTRIES (M) SDN. BHD.**

Lot 850, Jalan Subang 7, Taman Perindustrian Subang, 47500,  
Subang Jaya, Selangor D.E.

Tel: +603 80743399

Fax: +603 80743388

Website: [www.krugerfan.com](http://www.krugerfan.com)

**CAT043.E1.E2.KVM** November 2023

A member of

