

WE CARE FOR YOUR NEEDS.

DOWNBLAST ROOF EXHAUSTERS

RT/RE Series



ENERGY TWIN CITY
A TWIN CITY FAN COMPANY

CATALOGUE ID:
ETC-RT/RE-D 2022-ED01V2
OCTOBER 2022

TABLE OF CONTENTS

GENERAL INFORMATION..... 3

CONSTRUCTION FEATURES..... 4

OPTIONS & ACCESSORIES 5

FAN DATA

Direct Drive..... 6-10

Belt Driven 11-17

ACCESSORIES DIMENSIONS 18

TYPICAL SPECIFICATIONS 19

MODEL ORDER CODE:

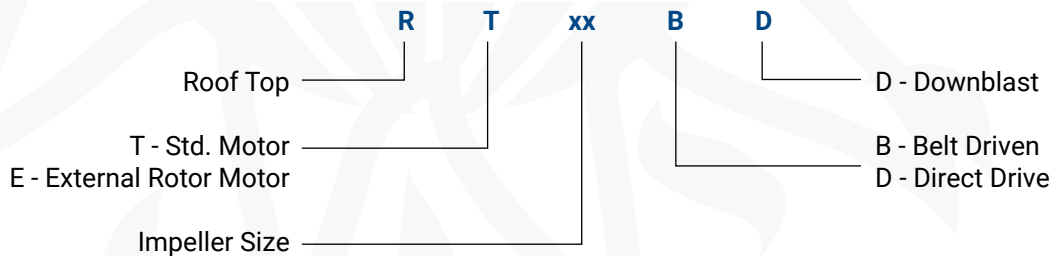

Overview

RExxDD | RTxxDD | RExxBD | RTxxBD

Energy Twin City's line of quiet, efficient and economical spun aluminum centrifugal power roof and wall exhausters are designed to offer value and long-lasting service in a wide variety of commercial and industrial ventilating applications.

STRUCTURAL INTEGRITY

Durable housings of spun aluminum have a high strength-to-weight ratio and incorporate a rolled bead for additional strength. There are no welds to break or seams to leak. The heavy-gauge motor mounting platform provides positive rigidity between all components of the power train assembly.

TYPICAL APPLICATIONS INCLUDE

Agriculture, Automotive, Boilers, Brick, Car Wash, Commercial Plan & Spec, Composting, Ethanol, Food & Beverage, Foundry, General Manufacturing, Glass, HVAC, Institutional & Hospitality, Metal & Minerals, Microchip, OEM, Pharmaceutical, Power Generation, Recycling, Textile, Transportation

IMPELLER TYPE

Backward Inclined/Curved Centrifugal

OPTIONAL CONSTRUCTION

Special Coatings, IEC-ex Spark Resistant

EASY MAINTENANCE ACCESS

By removing the fasteners, the motor dome lifts off for complete access to all the drive train components.



Office Building Application

MOTOR SELECTION

Both direct drive and belt driven models are available with a wide range of voltages and enclosures. Standard belt driven TEFC selected using a conservative portion of the IEC/NEMA service factor. Standard direct drive TEAO motors have Class B/F insulation and internal thermal overload protection. Each size is carefully engineered to match the motor to the impeller capacity.

INTERNAL WIRING

ODP/TEAO motors are factory-wired between the motor and junction box. For either direct drive or belt driven models, an electric disconnect is available.

CONFIGURATIONS

RExxDD (Direct Drive)

Available in five sizes – 9.0" to 16.0" impeller diameters
External Rotor Motor

RTxxDD (Direct Drive)

Available in five sizes – 8.0" to 16.0" impeller diameters
Std. Induction Motor

RTxxBD (Belt Driven)

Available in seven sizes – 12.0" to 36.0" impeller diameters
Std. Induction Motor

CERTIFICATIONS



Energy Industrial Company L.L.C. certifies that the models RE09DD, RE10DD, RE12DD, RE13DD & RE16DD shown herein are licensed to bear the AMCA Seal. The rating shown are based on tests and procedures performed in accordance with AMCA publication 211 and AMCA publication 311 and comply with the requirements of the AMCA Certified Ratings Program.



CE Conformity with Low Voltage Directive 2014/35/EU relating to electrical equipment designed for use within certain voltage limits.



Restriction of Hazardous Substances in Electrical and Electronic Equipment.

CONSTRUCTION FEATURES

DOWNBLAST ROOF EXHAUSTERS



HOUSINGS

RT and RE housings feature heavy-gauge spun aluminum construction of the shroud and top cover. Shrouds feature a rolled bead edge for rigidity. All housings provide complete protection of the motor and drive assembly, while allowing quick access to these components.

EASY MAINTENANCE ACCESS

By removing the fasteners, the motor chamber and chamber cover lifts off for complete access to all of the drive train components.

CHAMBER COVER

Provides complete protection for the motor and drive assembly, while allowing quick access to these components without the need for tools.

MOTOR CHAMBER

Constructed from heavy-gauge aluminum, rolled and beaded, for durability and appearance.

MOTORS

ODP, TEFC, TEAO and explosion proof, single and three phase motors are carefully matched to the fan load.

INTERNAL WIRING

Single phase motors are factory-wired between the motor and junction box. For either direct drive or belt driven models, an electric disconnect is available.

BEARINGS

Heavy-duty re-greaseable pillow block ball bearings are specifically designed for air handling applications to provide an average life (L-50) of 500,000 hours or more at maximum cataloged operating speeds.

SHAFT

Precision ground and polished with a first critical speed of at least 125% of the fan's maximum operating speed.

DRIVE

Adjustable pitch V-belt drives with cast iron sheaves and heat resistant belts are selected at 150% of the driven motor horsepower.

VIBRATION ISOLATION

Motor and drive assembly is completely isolated from the fan supports by rubber isolators to reduce transmission of noise and vibration.

IMPELLER

Non-overloading impellers with backwardly curved blades are precisely matched to a deep spun venture. All impellers are statically and dynamically balanced to ensure smooth and quiet operation.

GALVANIZED BIRD SCREEN

Protects the impeller, inlet and internal components from entry of birds.

CURB CAP

One-piece curb cap/inlet venture assembly provides protection from weather. Pre-punched mounting holes provide easy and accurate attachment to the roof curb.

CONDUIT TUBING

A conduit tube is furnished for running electrical wiring through the curb cap and into the motor compartment.

BACKDRAFT DAMPER

With automatic or motorized operation, features a felt seal on the edge of the damper blades for quiet operation. Damper frames are constructed of steel and blades are constructed of aluminum.



NEMA 1 DISCONNECT SWITCH

Mounted in the motor compartment when ODP or TEFC motors are used. When explosion proof motors are specified, a NEMA 7/9 disconnect switch will be shipped loose for field mounting and wiring.



NEMA 4 DISCONNECT SWITCH (OPTIONAL)

Mounted externally and is water- and dust-tight. Switch is available shipped loose for field mounting and wiring or factory mounted and wired.



ROOF CURB

Constructed of galvanized steel with continuous, wide base plate (flashing) to ensure watertight seal to roof, wood nailer secured to top ledge, lined with fiberglass fire-resistant, sound-absorbing insulation. Optional aluminum construction is available.



BIRD SCREEN

Galvanized mesh is standard. Optional aluminum or stainless steel rigid wire is also available.



VARIABLE SPEED CONTROL

Allows the adjustment of airflow for system balancing. Variable speed controllers are solid state design, variable speed controls can be shipped separately.



NEMA 3R DISCONNECT SWITCH

Externally mounted when ODP or TEFC motors are used. NEMA 3R, rain proof, disconnects are available shipped loose for field mounting and wiring or factory mounted and wired.



NEMA 7/9 DISCONNECT SWITCH

Provided on fans with explosion proof motors. The NEMA 7/9 switch is designed for use with fans operating in hazardous environments. NEMA 7/9 disconnect switch will be shipped loose for field mounting and wiring.



VENTED ROOF CURB

Self-flashing style curbs with ventilation louvers allow ambient air in to cool and dilute grease- or smoke-laden airstreams.



ADDITIONAL ACCESSORIES

- Special coatings
- AMCA Spark B or C
- Aluminum bird screen
- Stainless steel hardware/accessories
- Insect screen

RE SERIES DIRECT DRIVE FAN DATA

DOWNBLAST ROOF EXHAUSTERS

RE09DD

➤ Dimensional Data

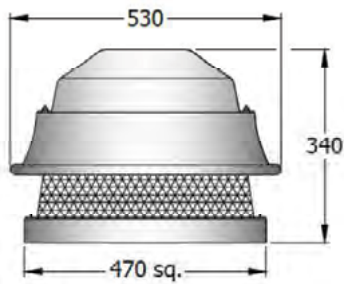

All dimensions in mm.

Roof Opening	225 x 225
Damper Size	215 x 215
Weight (kg)	20

➤ Performance Curve

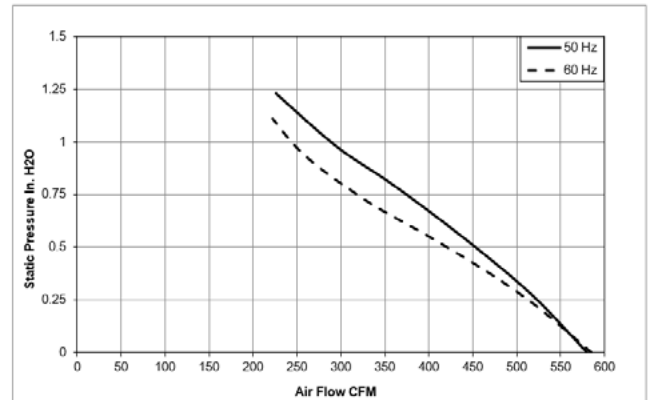

➤ Performance Data

Hz	KW*	A	RPM	0.000" Pst		0.125" Pst		0.250" Pst		0.375" Pst		0.500" Pst		0.625" Pst		0.750" Pst		1.000" Pst	
				CFM	Sones	CFM	Sones	CFM	Sones	CFM	Sones	CFM	Sones	CFM	Sones	CFM	Sones	CFM	Sones
50	0.13	0.55	2450	581	17.5	552	17.5	523	17.5	489	13.7	453	13.7	415	13.7	374	13.7	289	11.0
60	0.17	0.74	2700	585	17.8	549	17.8	512	16.0	469	16.0	420	11.8	369	11.8	320	11.8	246	9.1

1. Performance certified is for installation type A: Free Inlet, Free Outlet.
2. The sound ratings shown are for loudness values in fan sonas at 5' (1.5m) in a hemispherical free field per AMCA International Standard 301.
3. * Maximum input power

RE10DD

➤ Dimensional Data

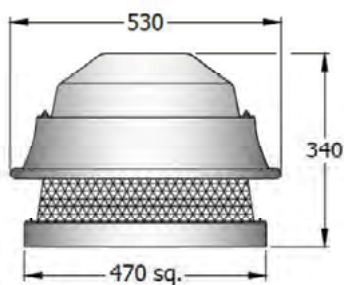

All dimensions in mm.

Roof Opening	300 x 300
Damper Size	290 x 290
Weight (kg)	21

➤ Performance Curve

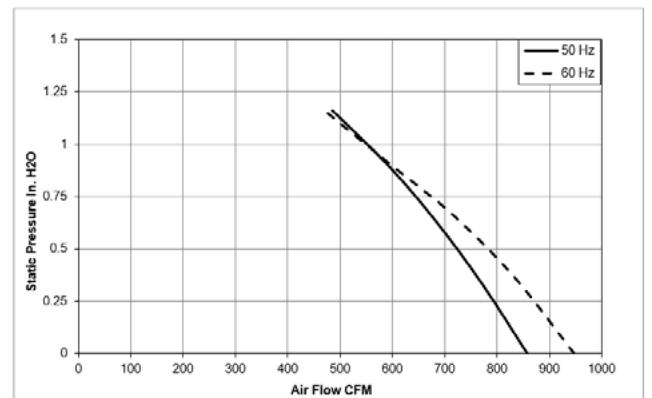

➤ Performance Data

Hz	KW*	A	RPM	0.000" Pst		0.125" Pst		0.250" Pst		0.375" Pst		0.500" Pst		0.625" Pst		0.750" Pst		1.000" Pst	
				CFM	Sones	CFM	Sones	CFM	Sones	CFM	Sones	CFM	Sones	CFM	Sones	CFM	Sones	CFM	Sones
50	0.18	0.78	2800	858	18.9	826	18.9	793	18.9	759	18.9	722	18.9	686	16.3	643	16.3	551	13.3
60	0.22	1.05	2850	947	23	908	23	869	23	829	23	780	23	731	17.6	673	17.6	550	17.6

1. Performance certified is for installation type A: Free Inlet, Free Outlet.
2. The sound ratings shown are for loudness values in fan sonas at 5' (1.5m) in a hemispherical free field per AMCA International Standard 301.
3. * Maximum input power

RE12DD

➤ Dimensional Data

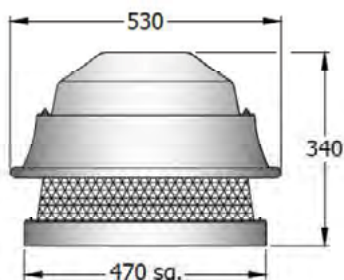

All dimensions in mm.

Roof Opening
300 x 300
Damper Size
290 x 290
Weight (kg)
22.5

➤ Performance Curve

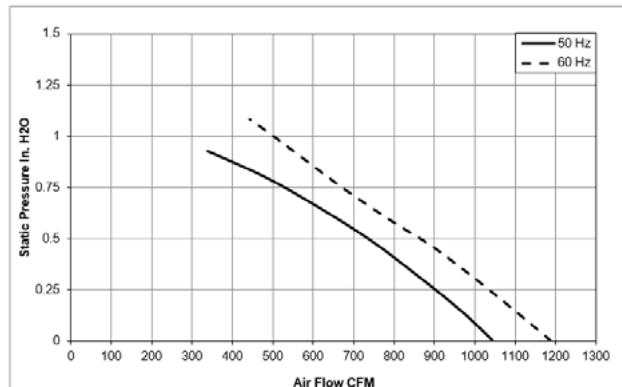

➤ Performance Data

Hz	KW*	A	RPM	0.000" Pst		0.125" Pst		0.250" Pst		0.375" Pst		0.500" Pst		0.625" Pst		0.750" Pst		1.000" Pst	
				CFM	Sones	CFM	Sones	CFM	Sones	CFM	Sones	CFM	Sones	CFM	Sones	CFM	Sones	CFM	Sones
50	0.13	0.60	1400	1045	11	977	11	901	11	820	8.8	735	8.8	635	7.1	527	7.1	—	—
60	0.18	0.80	1580	1189	14	1112	14	1035	14	952	11.5	862	11.5	764	9.2	670	9.2	500	8.8

1. Performance certified is for installation type A: Free Inlet, Free Outlet.
2. The sound ratings shown are for loudness values in fan sonas at 5' (1.5m) in a hemispherical free field per AMCA International Standard 301.
3. * Maximum input power

RE13DD

➤ Dimensional Data

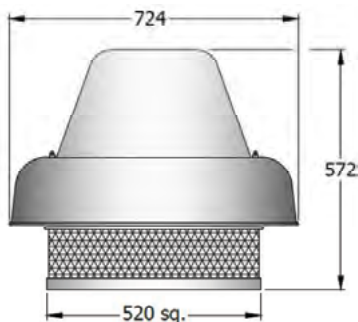

All dimensions in mm.

Roof Opening
400 x 400
Damper Size
390 x 390
Weight (kg)
25

➤ Performance Curve

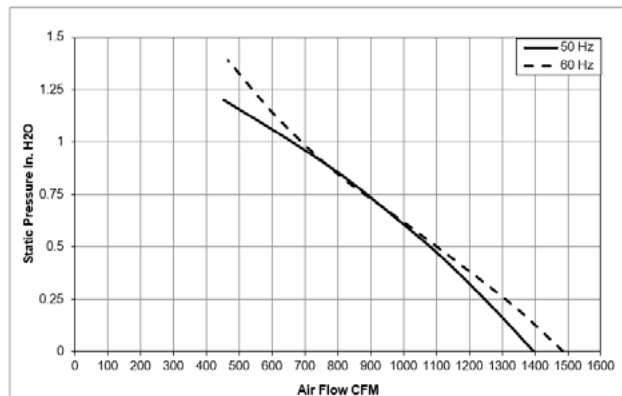

➤ Performance Data

Hz	KW*	A	RPM	0.000" Pst		0.125" Pst		0.250" Pst		0.375" Pst		0.500" Pst		0.625" Pst		0.750" Pst		1.000" Pst	
				CFM	Sones	CFM	Sones	CFM	Sones	CFM	Sones	CFM	Sones	CFM	Sones	CFM	Sones	CFM	Sones
50	0.20	0.88	1340	1396	14.2	1322	14.2	1246	14.2	1166	14.2	1080	12.0	986	12.0	661	12.0	—	—
60	0.28	1.25	1380	1485	15.3	1400	15.3	1308	14.2	1206	14.2	1100	14.2	994	11.9	695	11.9	542	11.9

1. Performance certified is for installation type A: Free Inlet, Free Outlet.
2. The sound ratings shown are for loudness values in fan sonas at 5' (1.5m) in a hemispherical free field per AMCA International Standard 301.
3. * Maximum input power

RE/RT SERIES DIRECT DRIVE FAN DATA

DOWNBLAST ROOF EXHAUSTERS

RE16DD

➤ Dimensional Data

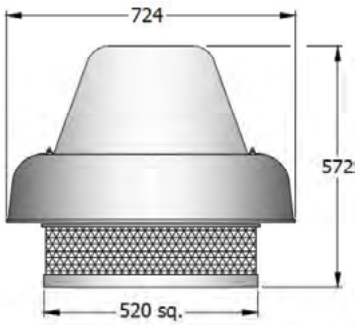

All dimensions in mm.

Roof Opening
400 x 400
Damper Size
390 x 390
Weight (kg)
29

➤ Performance Curve

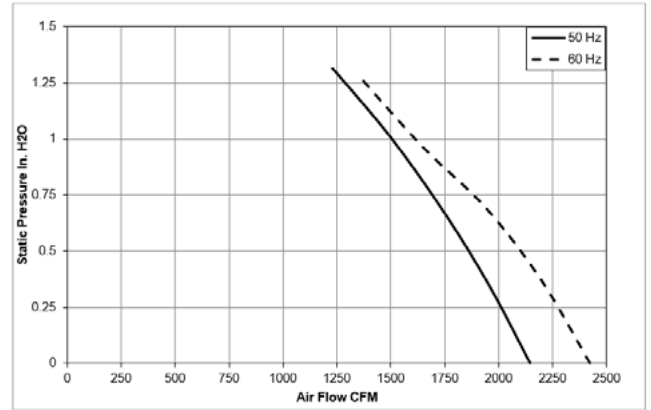

➤ Performance Data

Hz	KW*	A	RPM	0.000" Pst		0.125" Pst		0.250" Pst		0.375" Pst		0.500" Pst		0.625" Pst		0.750" Pst		1.000" Pst	
				CFM	Sones	CFM	Sones	CFM	Sones	CFM	Sones	CFM	Sones	CFM	Sones	CFM	Sones	CFM	Sones
50	0.43	1.50	1380	2144	23	2076	23	2008	23	1936	23	1857	23	1778	19.4	1505	19.4	1288	19.4
60	0.61	1.80	1656	2420	27	2344	27	2268	27	2190	25	2091	25	1992	25	1612	21	1378	21

1. Performance certified is for installation type A: Free Inlet, Free Outlet.
2. The sound ratings shown are for loudness values in fan sones at 5' (1.5m) in a hemispherical free field per AMCA International Standard 301.
3. * Maximum input power

RT08DD

➤ Dimensional Data

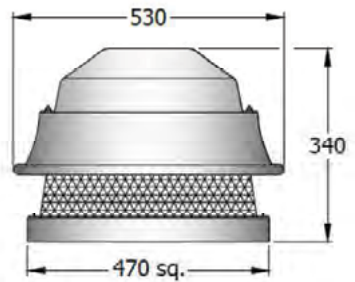

All dimensions in mm.

Roof Opening
225 x 225
Damper Size
215 x 215
Weight (kg)
20

➤ Performance Curve

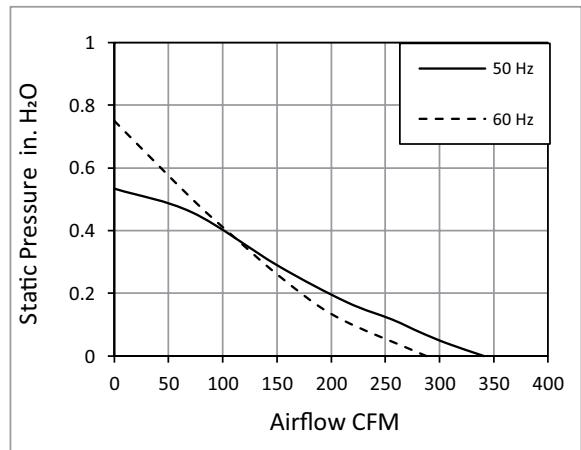

➤ Performance Data

Hz	KW*	A	RPM	0.000" Pst		0.125" Pst		0.250" Pst		0.375" Pst		0.500" Pst		0.625" Pst		1.000" Pst		1.500" Pst	
				CFM	Sones	CFM	Sones	CFM	Sones	CFM	Sones	CFM	Sones	CFM	Sones	CFM	Sones	CFM	Sones
50	0.05	0.53	1292	241	1.4	165	1.7	110	2.5	60	3.5	-	-	-	-	-	-	-	-
60	0.05	0.64	1550	284	2.4	190	2.8	140	3.5	92	4.1	53	4.9	-	-	-	-	-	-

RT10DD

➤ Dimensional Data

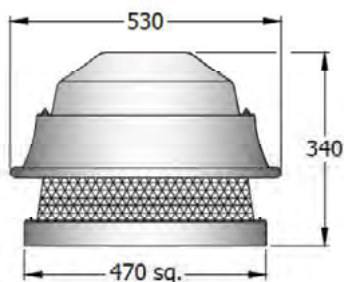

All dimensions in mm.

Roof Opening
300 x 300
Damper Size
290 x 290
Weight (kg)
21

➤ Performance Curve

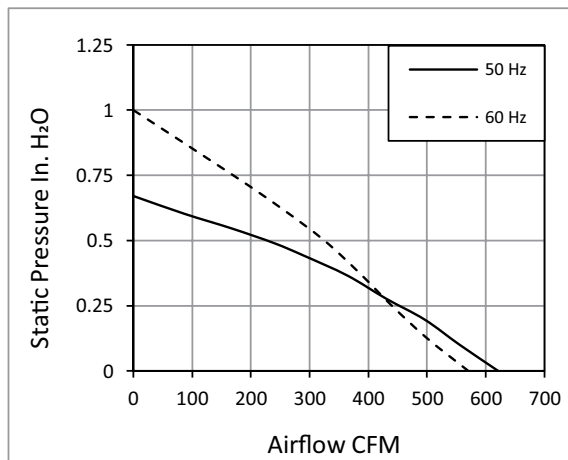

➤ Performance Data

Hz	KW*	A	RPM	0.000" Pst		0.125" Pst		0.250" Pst		0.375" Pst		0.500" Pst		0.625" Pst		0.750" Pst		1.000" Pst	
				CFM	Sones	CFM	Sones	CFM	Sones	CFM	Sones	CFM	Sones	CFM	Sones	CFM	Sones	CFM	Sones
50	0.12	0.90	1292	465	4.1	398	4.1	333	4.4	262	4.7	167	4.9	-	-	-	-	-	-
60	0.12	1.2	1550	555	6.1	500	5.9	442	6.1	393	6.5	325	6.8	266	7.0	179	7.2	-	-

RT11DD

➤ Dimensional Data

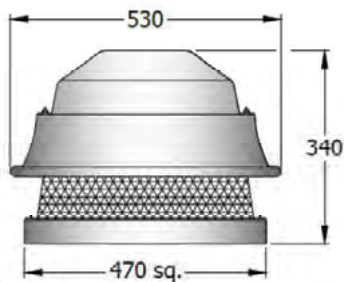

All dimensions in mm.

Roof Opening
300 x 300
Damper Size
290 x 290
Weight (kg)
22.5

➤ Performance Curve

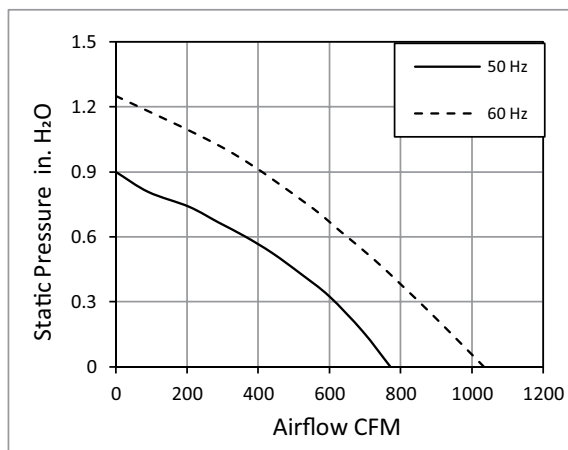

➤ Performance Data

Hz	KW*	A	RPM	0.000" Pst		0.125" Pst		0.250" Pst		0.375" Pst		0.500" Pst		0.625" Pst		1.000" Pst		1.250" Pst	
				CFM	Sones	CFM	Sones	CFM	Sones	CFM	Sones	CFM	Sones	CFM	Sones	CFM	Sones	CFM	Sones
50	0.26	1.40	1437	830	7.4	741	7.1	646	7.0	546	6.8	443	6.6	320	6.4	-	-	-	-
60	0.26	1.68	1725	992	10.2	918	9.7	845	9.5	761	9.5	595	9.4	505	9.2	291	8.9	-	-

RT SERIES DIRECT DRIVE FAN DATA

DOWNBLAST ROOF EXHAUSTERS

RT13DD

➤ Dimensional Data

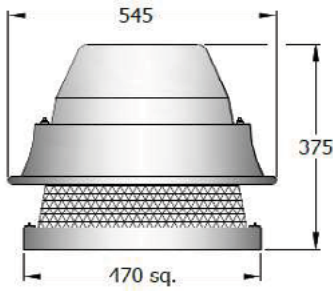

All dimensions in mm.

Roof Opening
300 x 300
Damper Size
290 x 290
Weight (kg)
25

➤ Performance Curve

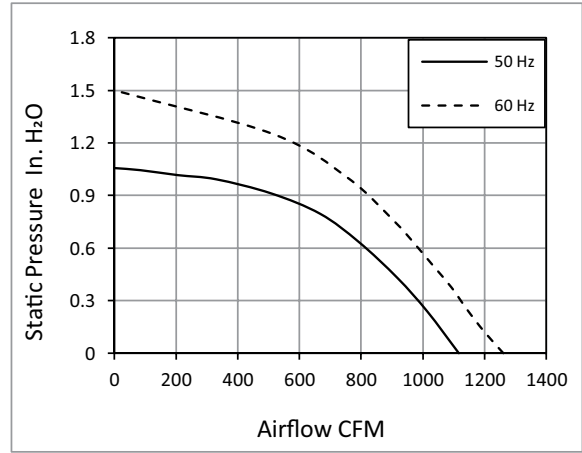

➤ Performance Data

Hz	KW*	A	RPM	0.000" Pst		0.125" Pst		0.250" Pst		0.375" Pst		0.500" Pst		0.625" Pst		1.000" Pst		1.500" Pst	
				CFM	Sones	CFM	Sones	CFM	Sones	CFM	Sones	CFM	Sones	CFM	Sones	CFM	Sones	CFM	Sones
50	0.31	1.90	1437	1066	11.6	1001	10.8	931	10.1	861	9.6	791	9.2	710	8.7	-	-	-	-
60	0.31	2.30	1725	1278	16	1222	15	1165	14	1110	14	1055	13	990	12	800	11	625	11

RT16DD

➤ Dimensional Data

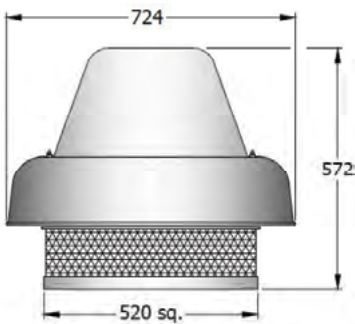

All dimensions in mm.

Roof Opening
400 x 400
Damper Size
390 x 390
Weight (kg)
29

➤ Performance Curve

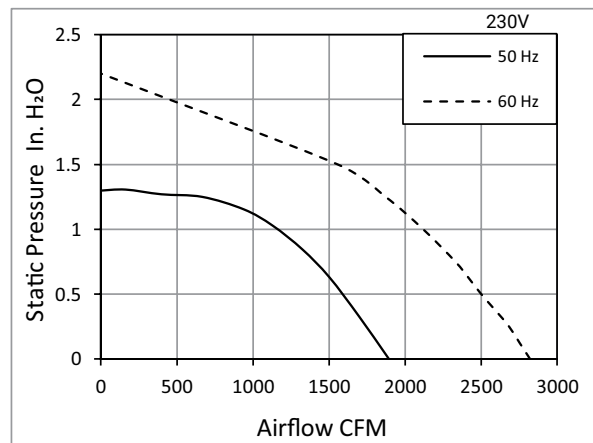

➤ Performance Data

Hz	KW*	A	RPM	0.000" Pst		0.125" Pst		0.250" Pst		0.375" Pst		0.500" Pst		0.625" Pst		1.000" Pst		1.500" Pst	
				CFM	Sones	CFM	Sones	CFM	Sones	CFM	Sones	CFM	Sones	CFM	Sones	CFM	Sones	CFM	Sones
50	0.86	3.90	1437	2512	13.3	2398	12.8	2296	12.3	2196	11.8	2086	11.4	1955	10.9	1486	10.2	-	-
60	0.86	4.70	1725	3015	18	2925	17	2830	16	2750	16	2660	15	2572	15	2251	14	2000	13

RT12BD

➤ Dimensional Data

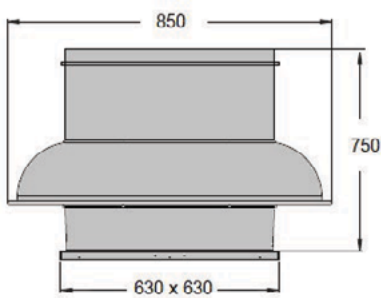

All dimensions in mm.

Roof Opening	Max Mtr. Frame
400 x 400	81
Damper Size	Weight (kg)
390 x 390	48

➤ Performance Curve

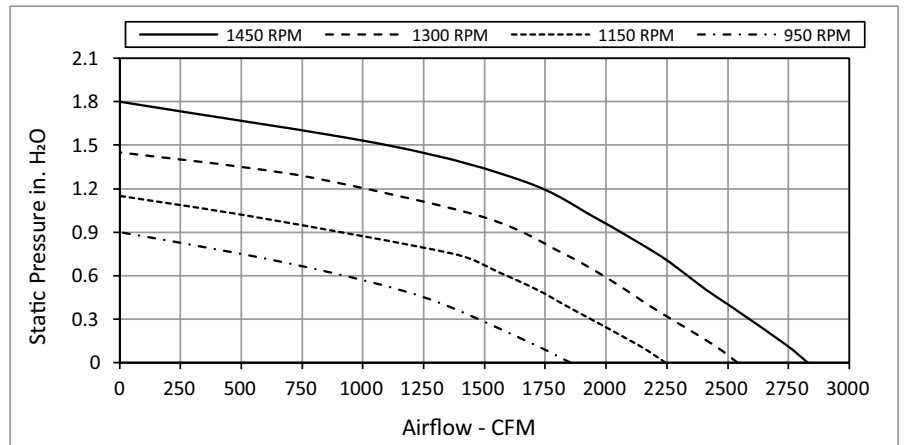

➤ Performance Data

Motor HP	Fan RPM	0.000" Pst		0.125" Pst		0.375" Pst		0.500" Pst		0.625" Pst		0.750" Pst		1.000" Pst		1.250" Pst	
		CFM		CFM		CFM		CFM		CFM		CFM		CFM		CFM	
		Sones	BHP	Sones	BHP	Sones	BHP	Sones	BHP	Sones	BHP	Sones	BHP	Sones	BHP	Sones	BHP
1/4	700	1368		1151		-		-		-		-		-		-	
		9.4	0.06	8.7	0.07	-		-		-		-		-		-	
1/4	850	1658		1485		1084		769		-		-		-		-	
		11.5	0.11	10.8	0.13	10.2	0.14	9.6	0.12	-		-		-		-	
1/3	950	1853		1703		1371		1155		858		-		-		-	
		12.9	0.16	12.3	0.17	11.4	0.19	11.0	0.20	10.4	0.19	-		-		-	
1/3	1050	2020		1894		1597		1422		1219		930		-		-	
		13.7	0.21	13.2	0.22	12.2	0.25	11.7	0.26	11.6	0.26	11.2	0.25	-		-	
1/2	1100	2146		2023		1740		1591		1408		1197		-		-	
		14.5	0.24	13.9	0.26	12.9	0.29	12.5	0.30	12.3	0.31	12.2	0.31	-		-	
1/2	1150	2244		2128		1854		1719		1556		1373		572		-	
		15.3	0.28	14.7	0.29	13.7	0.33	13.3	0.34	12.9	0.35	12.9	0.36	12.0	0.28	-	
1/2	1250	2439		2333		2077		1963		1831		1676		1300		-	
		17.2	0.36	16.8	0.37	15.7	0.42	15.1	0.43	14.7	0.44	14.4	0.45	14.5	0.45	-	
1/2	1300	2540		2439		2195		2080		1963		1827		1503		869	
		18.1	0.40	17.6	0.42	16.6	0.46	16.0	0.48	15.4	0.49	14.7	0.51	14.9	0.52	14.5	0.45
3/4	1350	2635		2536		2303		2190		2083		1956		1654		1248	
		18.9	0.45	18.4	0.47	17.4	0.51	16.8	0.53	16.3	0.54	15.7	0.56	15.1	0.58	15.6	0.56
3/4	1450	2829		2738		2524		2413		2315		2210		1955		1663	
		21.0	0.56	20.0	0.58	19.3	0.62	18.7	0.65	18.2	0.66	17.6	0.68	16.6	0.70	16.6	0.72
3/4	1500	2925		2833		2627		2520		2421		2327		2090		1811	
		22.0	0.61	21.0	0.63	20.0	0.68	19.7	0.71	19.2	0.72	18.7	0.74	17.5	0.77	17.3	0.79

RT SERIES BELT DRIVEN FAN DATA

DOWNBLAST ROOF EXHAUSTERS

RT14BD

➤ Dimensional Data

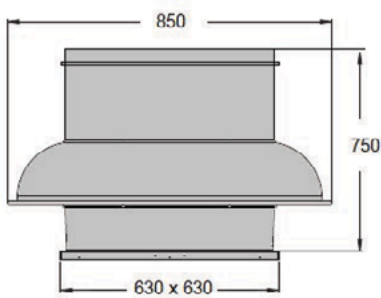

All dimensions in mm.

Roof Opening	Max Mtr. Frame
400 x 400	90
Damper Size	Weight (kg)
390 x 390	48

➤ Performance Curve

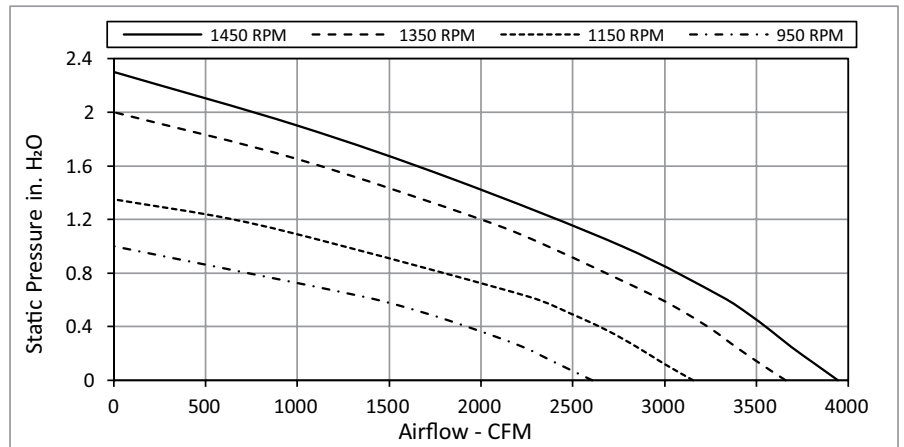

➤ Performance Data

Motor HP	Fan RPM	0.000" Pst		0.125" Pst		0.250" Pst		0.375" Pst		0.500" Pst		0.625" Pst		1.000" Pst		1.500" Pst	
		CFM		CFM		CFM		CFM		CFM		CFM		CFM		CFM	
		Sones	BHP	Sones	BHP	Sones	BHP	Sones	BHP	Sones	BHP	Sones	BHP	Sones	BHP	Sones	BHP
1/3	850	2295	0.15	2077	0.17	1835	0.18	1522	0.18	1104	-	-	-	-	-	-	-
	950	2606	0.23	2415	0.24	2226	0.26	1977	0.26	1699	1355	-	-	-	-	-	-
	1000	2720	0.26	2536	0.27	2360	0.29	2135	0.30	1870	1588	-	-	-	-	-	-
1/2	1050	2885	0.31	2708	0.32	2549	0.34	2348	0.35	2106	1854	-	-	-	-	-	-
	1150	3155	0.40	2995	0.42	2847	0.44	2683	0.46	2484	2257	1251	-	-	-	-	-
	1200	3264	0.45	3109	0.46	2965	0.48	2812	0.50	2627	2412	1629	10.6	0.49	-	-	-
3/4	1300	3577	0.59	3435	0.60	3306	0.62	3173	0.65	3019	2844	2238	13.3	0.67	-	-	-
	1350	3659	0.63	3520	0.65	3387	0.67	3262	0.69	3116	2944	2363	14.0	0.72	-	-	-
1	1400	3808	0.71	3675	0.73	3546	0.75	3426	0.77	3293	3140	2587	15.5	0.82	13.2	0.53	939
	1450	3942	0.79	3816	0.81	3689	0.83	3574	0.85	3451	3309	2783	16.8	0.91	14.0	0.85	1848
	1500	4075	0.87	3951	0.89	3826	0.91	3714	0.93	3602	3465	2974	18.1	1.01	14.6	0.97	2200

RT16BD

➤ Dimensional Data

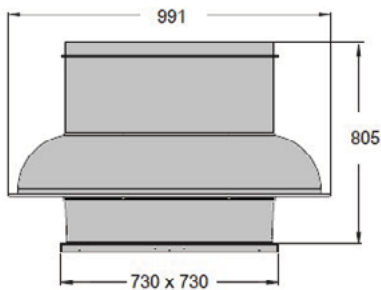

All dimensions in mm.

Roof Opening	Max Mtr. Frame
500 x 500	90
Damper Size	Weight (kg)
490 x 490	60

➤ Performance Curve

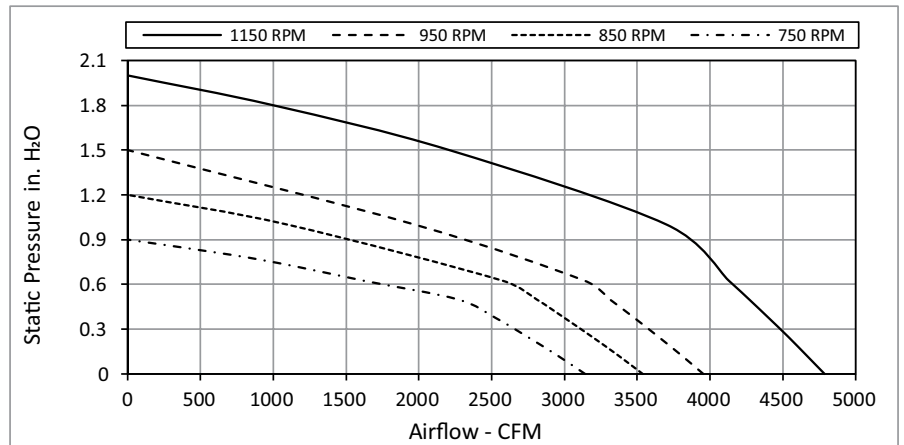

➤ Performance Data

Motor HP	Fan RPM	0.000" Pst		0.125" Pst		0.250" Pst		0.375" Pst		0.500" Pst		0.625" Pst		1.000" Pst		1.500" Pst	
		CFM		CFM		CFM		CFM		CFM		CFM		CFM		CFM	
		Sones	BHP	Sones	BHP	Sones	BHP	Sones	BHP	Sones	BHP	Sones	BHP	Sones	BHP	Sones	BHP
1/3	700	2971	0.25	2772	0.27	2552	0.28	2323	0.29	1948	0.29	907	0.20	-	-	-	-
	750	3142	0.30	2950	0.31	2744	0.33	2528	0.34	2266	0.34	1620	0.31	-	-	-	-
1/2	800	3330	0.35	3151	0.37	2957	0.38	2755	0.40	2546	0.41	2183	0.40	-	-	-	-
	850	3538	0.42	3368	0.44	3188	0.46	3001	0.47	2808	0.49	2575	0.49	-	-	-	-
3/4	900	3850	0.54	3694	0.56	3531	0.58	3362	0.60	3187	0.62	3009	0.63	1563	0.50	-	-
	950	3954	0.59	3803	0.61	3642	0.63	3481	0.65	3311	0.66	3138	0.68	1972	0.60	-	-
1	1000	4266	0.74	4126	0.76	3982	0.78	3831	0.80	3676	0.82	3518	0.84	2880	0.86	-	-
	1050	4500	0.87	4366	0.89	4231	0.92	4088	0.94	3943	0.96	3794	0.97	3299	1.01	-	-
1-1/2	1150	4787	1.04	4662	1.07	4532	1.10	4403	1.12	4268	1.14	4129	1.16	3703	1.21	2209	1.03
		5037	1.22	4918	1.24	4798	1.27	4673	1.30	4546	1.32	4416	1.34	4012	1.40	3056	1.36
	1250	5166	1.31	5055	1.34	4933	1.37	4812	1.39	4688	1.42	4563	1.44	4170	1.50	3398	1.51
		23.0	1.31	23.0	1.34	22.0	1.37	22.0	1.39	22.0	1.42	21.0	1.44	20.0	1.50	17.8	1.51

RT SERIES BELT DRIVEN FAN DATA

DOWNBLAST ROOF EXHAUSTERS

RT18BD

➤ Dimensional Data

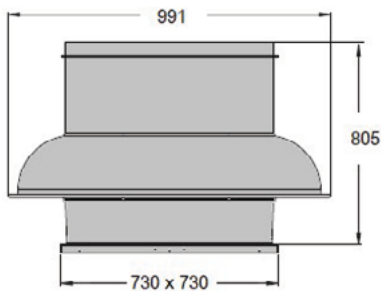

All dimensions in mm.

Roof Opening	Max Mtr. Frame
500 x 500	100
Damper Size	Weight (kg)
490 x 490	64

➤ Performance Curve

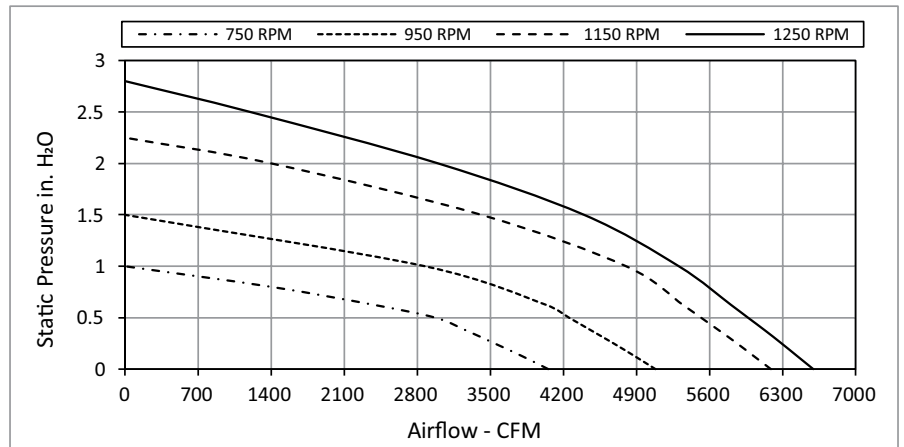

➤ Performance Data

Motor HP	Fan RPM	0.000" Pst		0.125" Pst		0.250" Pst		0.375" Pst		0.500" Pst		0.625" Pst		1.000" Pst		1.500" Pst	
		CFM		CFM		CFM		CFM		CFM		CFM		CFM		CFM	
		Sones	BHP	Sones	BHP	Sones	BHP	Sones	BHP	Sones	BHP	Sones	BHP	Sones	BHP	Sones	BHP
1/2	750	4052		3808		3542		3271		2974		2383		-		-	
		13.1	0.39	12.7	0.42	12.2	0.44	11.5	0.46	10.6	0.48	9.7	0.46	-	-	-	-
3/4	800	4345		4115		3868		3618		3357		3010		-		-	
		15.2	0.48	14.8	0.51	14.2	0.53	13.7	0.56	12.6	0.58	11.6	0.58	-	-	-	-
	850	4503		4281		4042		3804		3555		3278		-		-	
		15.5	0.53	15.1	0.57	14.6	0.59	14.1	0.62	13.2	0.64	12.2	0.65	-	-	-	-
1	900	4804		4595		4376		4151		3923		3684		1675		-	
		17.1	0.65	16.8	0.68	16.3	0.71	15.8	0.74	15.1	0.76	14.3	0.78	12.3	0.59	-	-
1	950	5081		4886		4682		4469		4255		4034		2875		-	
		18.9	0.77	18.7	0.81	18.3	0.84	17.8	0.86	17.3	0.89	16.5	0.92	13.8	0.90	-	-
1-1/2	1000	5425		5241		5053		4853		4653		4451		3671		-	
		21.0	0.93	21.0	0.97	20.0	1.01	19.9	1.04	19.5	1.07	18.9	1.10	16.5	1.12	-	-
	1050	5610		5431		5251		5058		4865		4671		4006		-	
		22.0	1.03	21.0	1.07	21.0	1.12	21.0	1.14	20.0	1.17	19.5	1.20	17.3	1.25	-	-
1-1/2	1100	5792		5621		5448		5262		5075		4887		4290		-	
		22.0	1.13	22.0	1.18	22.0	1.23	21.0	1.25	21.0	1.28	20.0	1.31	18.1	1.39	-	-
2	1150	6189		6027		5860		5694		5520		5345		4802		3414	
		24.0	1.38	24.0	1.43	24.0	1.48	23.0	1.51	23.0	1.54	22.0	1.57	20.0	1.67	17.6	1.60
	1200	6321		6162		6004		5838		5667		5495		4967		3786	
		25.0	1.47	25.0	1.52	24.0	1.57	24.0	1.61	23.0	1.64	23.0	1.67	21.0	1.77	18.3	1.77
2	1250	6594		6443		6291		6134		5970		5806		5307		4399	
		26.0	1.67	26.0	1.73	26.0	1.78	26.0	1.82	25.0	1.85	25.0	1.88	23.0	1.99	21.0	2.00

RT24BD

► Dimensional Data

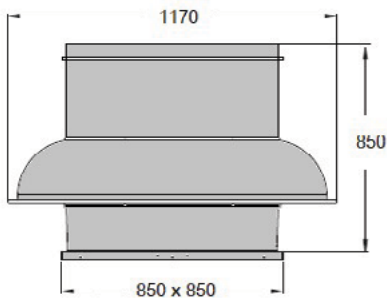

All dimensions in mm.

Roof Opening	Max Mtr. Frame
635 x 635	100
Damper Size	Weight (kg)
625 x 625	92

► Performance Curve

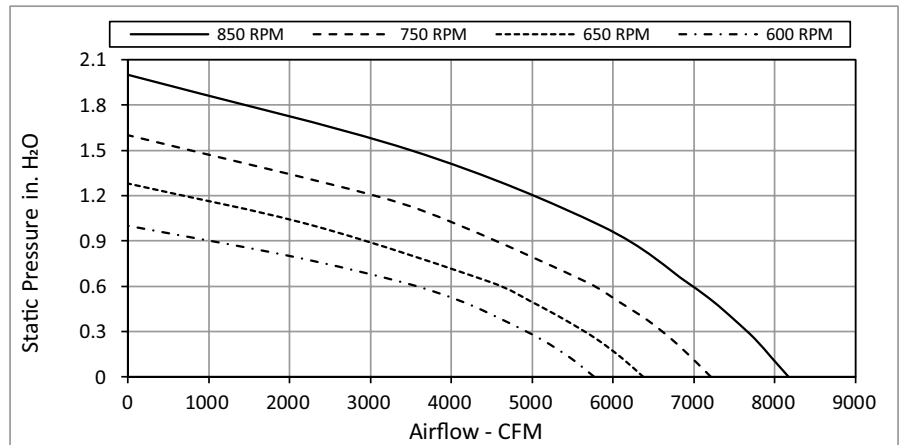

► Performance Data

Motor HP	Fan RPM	0.000" Pst		0.125" Pst		0.250" Pst		0.375" Pst		0.500" Pst		0.625" Pst		1.000" Pst		1.500" Pst	
		CFM		CFM		CFM		CFM		CFM		CFM		CFM		CFM	
		Sones	BHP	Sones	BHP	Sones	BHP	Sones	BHP	Sones	BHP	Sones	BHP	Sones	BHP	Sones	BHP
3/4	600	5762		5473		5100		4642		4122		3399		-		-	
		13.1	0.52	12.6	0.57	11.9	0.59	11.2	0.62	10.3	0.62	8.2	0.59	-	-	-	-
3/4	625	6003		5726		5382		4955		4484		3890		-		-	
		14.3	0.59	13.7	0.64	13.0	0.67	12.3	0.70	11.6	0.71	9.9	0.69	-	-	-	-
1	650	6365		6107		5793		5411		4980		4493		-		-	
		14.7	0.71	14.2	0.76	13.7	0.79	13.0	0.82	12.3	0.85	11.4	0.84	-	-	-	-
1	700	6720		6477		6191		5847		5450		5031		-		-	
		15.5	0.83	15.0	0.89	14.5	0.93	13.9	0.96	13.3	0.99	12.6	1.00	-	-	-	-
1-1/2	750	7200		6974		6720		6425		6063		5680		4113		-	
		17.0	1.02	16.6	1.09	16.1	1.14	15.5	1.16	14.9	1.20	14.3	1.22	11.1	1.15	-	-
1-1/2	775	7439		7222		6984		6697		6360		5992		4619		-	
		17.9	1.13	17.5	1.19	17.1	1.25	16.5	1.27	16.0	1.31	15.4	1.34	12.4	1.30	-	-
1-1/2	800	7725		7519		7296		7022		6713		6374		5182		-	
		19.1	1.27	18.6	1.33	18.1	1.40	17.6	1.42	17.0	1.45	16.5	1.50	14.1	1.48	-	-
2	850	8155		7963		7750		7505		7235		6912		5851		-	
		19.6	1.49	19.2	1.56	18.8	1.63	18.3	1.66	17.8	1.69	17.2	1.74	15.5	1.77	-	-
2	875	8529		8327		8129		7898		7648		7352		6384		4317	
		21.0	1.69	21.0	1.77	20.0	1.84	19.7	1.89	19.2	1.91	18.6	1.95	17.0	2.04	13.9	1.83

RT SERIES BELT DRIVEN FAN DATA

DOWNBLAST ROOF EXHAUSTERS

RT30BD

➤ Dimensional Data

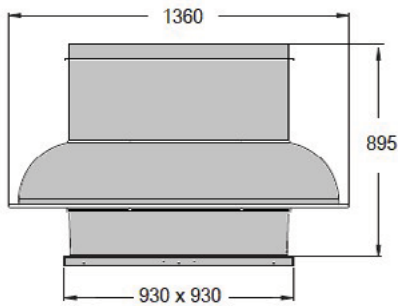

All dimensions in mm.

Roof Opening	Max Mtr. Frame
710 x 710	112
Damper Size	Weight (kg)
700 x 700	105

➤ Performance Curve

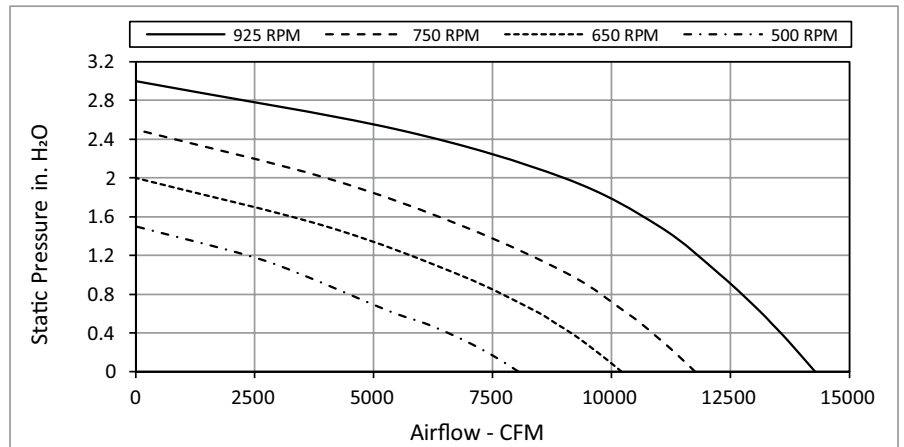

➤ Performance Data

Motor HP	Fan RPM	0.000" Pst		0.125" Pst		0.250" Pst		0.375" Pst		0.500" Pst		0.625" Pst		1.000" Pst		1.500" Pst	
		CFM		CFM		CFM		CFM		CFM		CFM		CFM		CFM	
		Sones	BHP	Sones	BHP	Sones	BHP	Sones	BHP	Sones	BHP	Sones	BHP	Sones	BHP	Sones	BHP
1	500	8040		7642		7195		6674		6071		5324		-		-	
		14.1	0.73	13.3	0.79	12.4	0.83	11.6	0.87	10.8	0.91	9.9	0.92	-	-	-	-
1-1/2	550	8661		8295		7890		7427		6927		6303		-		-	
		15.4	0.91	14.8	0.98	14.2	1.02	13.4	1.06	12.7	1.12	11.8	1.14	-	-	-	-
	600	9280		8938		8566		8153		7698		7192		4847		-	
		16.8	1.12	16.2	1.19	15.6	1.24	15.0	1.29	14.3	1.34	13.5	1.39	10.4	1.33	-	-
2	650	10200		9897		9567		9220		8820		8400		6798		-	
		19.1	1.49	18.6	1.57	18.1	1.63	17.6	1.68	17.0	1.73	16.2	1.80	13.4	1.88	-	-
	675	10471		10168		9842		9513		9129		8724		7235		-	
		19.5	1.61	19.0	1.69	18.6	1.75	18.2	1.80	17.7	1.86	16.9	1.92	14.2	2.03	-	-
3	700	10981		10692		10392		10073		9723		9346		8011		-	
		20.0	1.86	19.9	1.94	19.5	2.01	19.1	2.06	18.7	2.12	18.1	2.18	15.6	2.32	-	-
	750	11755		11480		11210		10910		10611		10263		9120		6886	
		22.0	2.28	22.0	2.37	21.0	2.45	21.0	2.51	21.0	2.56	20.0	2.63	17.9	2.83	14.8	2.79
	725	12018		11754		11488		11196		10905		10563		9485		7426	
		23.0	2.44	22.0	2.53	22.0	2.61	22.0	2.67	21.0	2.73	21.0	2.79	18.7	3.01	15.5	3.01
5	800	12602		12354		12102		11827		11549		11249		10244		8513	
		24.0	2.81	24.0	2.91	23.0	3.00	23.0	3.06	23.0	3.12	23.0	3.19	21.0	3.42	17.2	3.55
	900	13991		13771		13544		13308		13058		12808		11952		10610	
		28.0	3.85	28.0	3.96	28.0	4.06	27.0	4.15	27.0	4.22	27.0	4.28	26.0	4.50	22.0	4.79
	925	14275		14054		13831		13603		13355		13112		12284		11001	
		29.0	4.09	29.0	4.19	29.0	4.30	28.0	4.39	28.0	4.46	28.0	4.53	27.0	4.75	23.0	5.07

RT36BD

➤ Dimensional Data

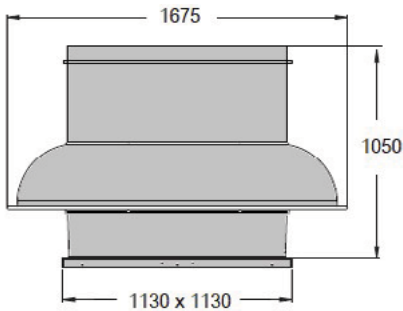

All dimensions in mm.

Roof Opening	Max Mtr. Frame
915 x 915	132
Damper Size	Weight (kg)
905 x 905	200

➤ Performance Curve

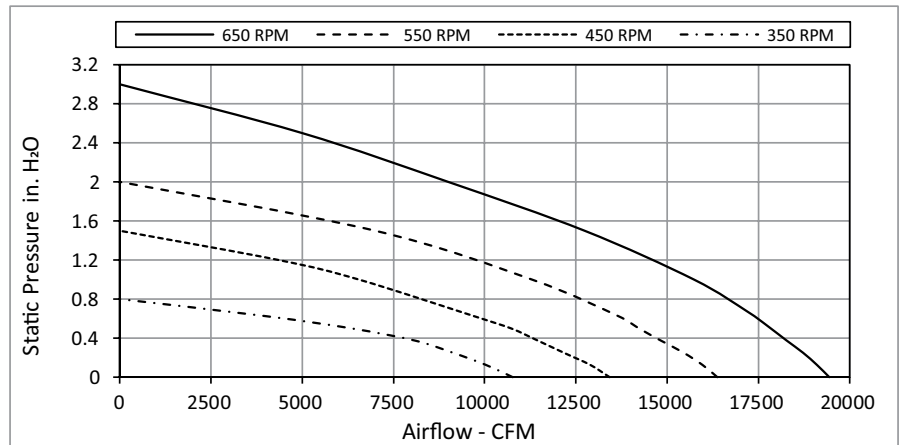

➤ Performance Data

Motor HP	Fan RPM	0.000" Pst		0.125" Pst		0.250" Pst		0.375" Pst		0.500" Pst		0.625" Pst		1.000" Pst		1.500" Pst				
		CFM		CFM		CFM		CFM		CFM		CFM		CFM		CFM				
		Sones	BHP	Sones	BHP	Sones	BHP	Sones	BHP	Sones	BHP	Sones	BHP	Sones	BHP	Sones	BHP			
1	350	10766	11.4	0.65	10037	11.1	0.72	9130	10.2	0.82	8086	9.7	0.87	6338	9.3	0.85	-	-		
	375	11065	12.0	0.71	10362	11.6	0.78	9469	10.8	0.88	8523	10.1	0.94	7027	9.6	0.93	-	-		
1-1/2	400	11800	13.5	0.86	11169	13.3	0.93	10314	12.5	1.04	9503	11.7	1.11	8351	10.9	1.16	-	-		
	425	12680	15.5	1.06	12115	15.4	1.15	11324	14.8	1.26	10586	14.0	1.35	9711	13.2	1.42	8478	12.3	1.42	
2	450	13425	17.0	1.26	12896	17.0	1.36	12165	16.5	1.46	11453	15.7	1.57	10719	15.0	1.65	9706	14.3	1.71	
	475	14270	18.8	1.52	13798	18.8	1.63	13136	18.6	1.71	12432	18.0	1.85	11778	17.2	1.95	10998	16.5	2.02	
3	500	14890	21.0	1.72	14449	21.0	1.85	13832	21.0	1.92	13143	20.0	2.07	12523	19.4	2.18	11839	18.6	2.26	
	550	16376	23.0	2.29	15969	23.0	2.43	15455	23.0	2.50	14826	22.0	2.65	14223	22.0	2.80	21.0	2.91	18.9	3.09
5	575	16965	24.0	2.55	16573	24.0	2.69	16091	24.0	2.77	15498	23.0	2.90	14902	23.0	3.07	22.0	3.20	20.0	3.45
	600	18143	27.0	3.12	17779	27.0	3.27	17345	27.0	3.37	16824	26.0	3.48	16245	26.0	3.66	25.0	3.82	23.0	4.13
	650	19441	29.0	3.83	19101	29.0	4.00	18722	29.0	4.13	18255	29.0	4.22	17730	28.0	4.38	28.0	4.57	26.0	4.97
		12737	23.0	5.10	12737	23.0	5.10	12737	23.0	5.10	12737	23.0	5.10	12737	23.0	5.10	12737	23.0	5.10	12737

ACCESSORIES DIMENSIONS

DOWNBLAST ROOF EXHAUSTERS

ROOF CURB

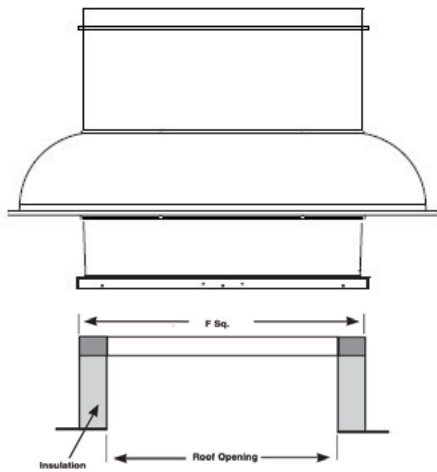

MODEL NO.	Roof Opening	Curb Size F Sq.
RE09DD	225 x 225	460 x 460
RE10DD	300 x 300	460 x 460
RE12DD	300 x 300	460 x 460
RE13DD	400 x 400	510 x 510
RE16DD	400 x 400	510 x 510
RT08DD	225 x 225	460 x 460
RT10DD	300 x 300	460 x 460
RT11DD	300 x 300	460 x 460
RT13DD	300 x 300	460 x 460
RT16DD	400 x 400	510 x 510
RT12BD	400 x 400	620 x 620
RT14BD	400 x 400	620 x 620
RT16BD	500 x 500	720 x 720
RT18BD	500 x 500	720 x 720
RT24BD	635 x 635	840 x 840
RT30BD	710 x 710	920 x 920
RT36BD	915 x 915	1120 x 1120

All dimensions in mm.

BACKDRAFT DAMPER

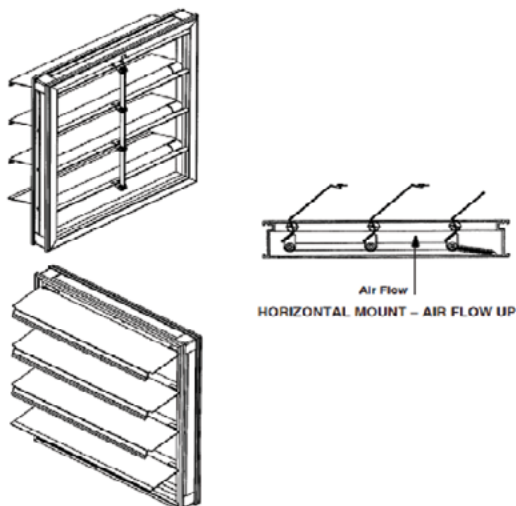

MODEL NO.	Curb Size F Sq.
RE09DD	215 x 215
RE10DD	290 x 290
RE12DD	290 x 290
RE13DD	390 x 390
RE16DD	390 x 390
RT08DD	215 x 215
RT10DD	290 x 290
RT11DD	290 x 290
RT13DD	290 x 290
RT16DD	390 x 390
RT12BD	390 x 390
RT14BD	390 x 390
RT16BD	490 x 490
RT18BD	490 x 490
RT24BD	625 x 625
RT30BD	700 x 700
RT36BD	905 x 905

All dimensions in mm.

Notes:

1. All dimensions are in mm unless otherwise noted.
2. Dimensions are not to be used for construction.
3. Damper sizes are nominal.

PERFORMANCE

Fans shall be tested in accordance with AMCA Standard 210 and AMCA Standard 300 test codes for air moving devices and shall be guaranteed by the manufacturer to deliver rated published performance levels. Fans shall be licensed to bear the AMCA certified ratings seal for both sound and air performance.

CONSTRUCTION

Fans shall be constructed of aluminum for durability and appearance. Fan spinning shall have rolled bead edge for rigidity. Units shall have a deep venture inlet to prevent snow and rain entry into the building. The curb cap shall include pre-punched mounting holes for ease of attachment.

INSTALLATION

Fans shall bear a permanently attached nameplate displaying model and serial number of the unit for future identification.

MOTOR ASSEMBLY

RT motors shall be mounted out of the exhaust airstream and RE motors shall be mounted within the exhaust airstream.

IMPELLER

Fan impellers shall be of the centrifugal backward inclined/curved type, constructed of aluminum and containing a matching inlet venturi for optimum unit performance. Impellers shall be statically and dynamically balanced.

MOTOR

Motors shall be heavy-duty ball bearing type, closely matched to the fan load. All single-phase TEAO motors shall contain thermal overload protection. Motors for use with speed control shall provide good speed controllability without any objectionable noise.

FINISH AND COATING

Fans shall be constructed of aluminum. Optional coatings shall be available.

ACCESSORIES

When specified, accessories such as backdraft damper, roof curb, variable speed controller, NEMA 4 disconnect switch, aluminum bird screen, aluminum insect screen and special coatings shall be provided by Energy Twin City.

FACTORY RUN TEST

Prior to shipment, all fans shall be completely assembled and test run as a unit at operating speed or maximum RPM allowed for the particular construction type. Each impeller shall be statically and dynamically balanced in accordance with ISO1940 G 2.5 or 6.3 "Balance Quality and Vibration Levels for Fans."

GUARANTEE

The manufacturer shall guarantee the workmanship and materials for its roof and wall mounted centrifugal exhaust fans for at least one (1) year from startup or eighteen (18) months from shipment, whichever occurs first.

**THE RECOGNIZED LEADER IN
MANUFACTURING AND DISTRIBUTION
OF HVAC AND INDUSTRIAL
PRODUCTS IN THE MIDDLE EAST.**



MIDDLE EAST

PO Box 24021, Sharjah Industrial Area
United Arab Emirates
Phone: 971.6534.3488 | Fax: 971.6534.3710
energyintl.com

UNITED STATES

5959 Trenton Lane, Minneapolis, MN 55442
Phone: 763.551.7600 | Fax: 763.551.7601
careers.tcf.com