



INDUSTRIAL PROCESS AND  
COMMERCIAL VENTILATION SYSTEMS

# LOW PRESSURE MIXED FLOW FANS

QCLB | QCLBR | QCLBSH



# MIXED FLOW FANS

QCLB  
(Horizontal)

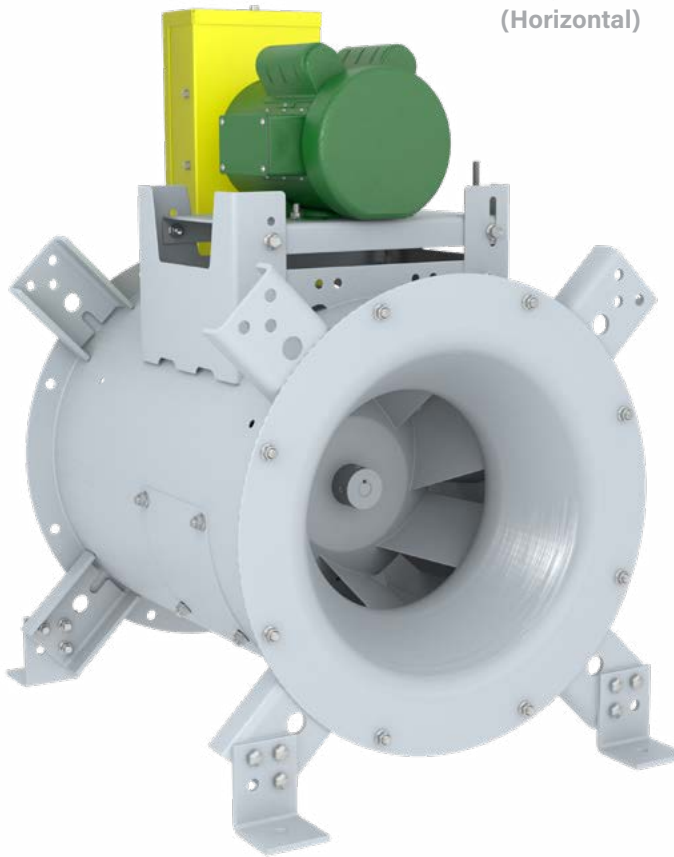

## Models

QCLB | QCLBR | QCLBSH

### Benefits of Mixed Flow Fans

Twin City Fan Model QCLB Mixed Flow Fans combine the benefits of axial flow and centrifugal flow fans. The QCLB has the advantages of an axial fan in its compact design and straight-through airflow combined with a centrifugal fan's preferred acoustical characteristics and high pressure capabilities. Mixed flow fans offer the most economy of operation when compared with equivalently sized tubular centrifugal or axial fans with a higher and broader efficiency range.

### Typical Applications Include

Data Center Exhaust, General HVAC, Generator Room Ventilation, Swimming Pool Exhaust, Kitchen Exhaust, Dishwasher Exhaust, Elevator Shaft Exhaust/Pressurization, Emergency Smoke Exhaust, Stairwell Pressurization

### Configurations

Belt Driven - vertical & horizontal mount configurations

### Impeller Types

Mixed Flow

### Standard Construction

Level 1 & 2

### Optional Construction

Spark Resistant, UL 705, UL 705 Supplement SC (formerly UL 762), UL Smoke & Heat

### Certifications

AMCA Sound/Air and FEI, UL 705 Listed for Electrical, UL Listed for Grease-Laden Air, UL Listed for Smoke Control Systems

Model QCLB is available with the UL/cUL 705 listing for electrical, File No. E158680.

Model QCLBR is UL/cUL listed for the exhaust of grease-laden air as standard, File No. E158680.

Model QCLBSH is UL/cUL listed for Smoke Control Systems as standard, File No. E158680, 500°F for 4 hours and 1000°F for 15 minutes.



Twin City Fan & Blower certifies that the Model QCLB, QCLBR and QCLBSH Mixed Flow Fans shown herein are licensed to bear the AMCA Seal. Certified performance data may be found in Twin City Fan & Blower's Fan Selector software.



Scan the QR code to search Twin City Fan & Blower's AMCA-certified products.



For complete product performance, drawings and available accessories, download our Fan Selector software at [tcf.com](http://tcf.com).

## Models

**QCLB | QCLBR | QCLBSH**

### General HVAC Fans

#### QCLB

12.25" to 73" impeller diameters  
Airflow to 105,000 CFM  
Static pressure to 4.5" w.g.



### Kitchen & Restaurant Fans

#### QCLBR

12.25" to 73" impeller diameters  
Airflow to 105,000 CFM  
Static pressure to 4.5" w.g.



### Smoke & Heat Applications

#### QCLBSH

12.25" to 73" impeller diameters  
Airflow to 105,000 CFM  
Static pressure to 4.5" w.g.



### Temperature Rating

500°F for 4 Hours  
1000°F for 15 Minutes



General HVAC  
Supply and Exhaust

## Energy Regulations

Twin City Fan & Blower supports energy efficiency regulations enacted by the Department of Energy (DOE) and energy commissions of specific states. The selection and application of fan products is a significant part of these regulations. Engineers and specifiers must understand how to apply TCF products to their specific applications to meet efficiency requirements. Twin City Fan & Blower has made significant investments in product testing to assure users will receive the most efficient products available. Developments in the Fan Selector software are in place to help aide in product selection to meet the efficiency requirements as stipulated in the regulations. Visit [tcf.com](http://tcf.com) for the latest on fan energy efficiency regulations.

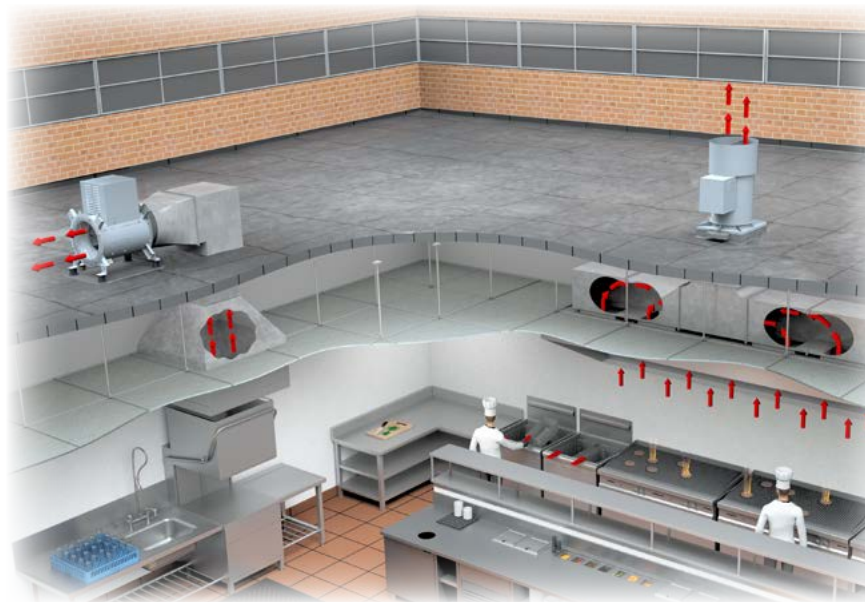

Smoke & Heat (Emergency Smoke Control)  
and Restaurant Exhaust



## QCLB Mixed Flow Fans

The QCLB Mixed Flow Fan is a popular choice for many air supply, return and exhaust air applications in the HVAC industry for both constant or variable air volume systems. The efficiency and sound characteristics of mixed flow fans are often desired in buildings such as hospitals, libraries, theaters and general offices. The heavy-duty construction of QCLB fans also makes them suitable for many industrial applications handling ambient air.

### Standard Product Features

- Belt guard, ventilated (weather cover for VRM)
- Stack cap (for VRM)
- Continuously-welded housing
- Inlet & outlet flanges
- Bolted access door



## QCLBR Restaurant Fans

Twin City Fan & Blower offers a specially modified version of the QCLB fan designated as "QCLBR" (Mixed Flow Restaurant Exhaust) for exhausting grease-laden air from kitchens, restaurants, cooking and dishwasher hoods. QCLBR is available in sizes 90 through 600.

Model QCLBR is cULus 705 Supplement SC (formerly UL 762) listed for exhaust of grease-laden air. QCLBR is licensed to bear the AMCA certified ratings seal for sound and air performance.

The QCLBR fan is available in all configurations with the exception of vertical down (VDO and VDI).

### Standard Product Features

- Belt guard, totally enclosed, ventilated (weather cover for VRM)
- Belt tube, sealed
- Two cleanout doors located 180° apart (90° from motor)
- 2" drain located 180° from motor (lowest point for horizontal) vertical at the funnel
- Cooling fins on impeller
- Housing sealed with Hi-Temp caulk
- Two (2) bolted access doors

## QCLBSH Smoke & Heat Fans

Twin City Fan & Blower offers a specially modified version of the QCLB fan designated as "QCLBSH" (Mixed Flow Smoke and Heat Exhaust) for smoke control applications where temperatures can reach 1000°F. QCLBSH is available in sizes 90 through 600.

Model QCLBSH is cULus 705 listed and cULus listed for smoke control systems for 500°F for 4 hours or 1000°F for 15 minutes. Vertical roof mounted configuration, with stack cap, meets UL 793 Snow Load Test requirements for butterfly dampers. QCLBSH is licensed to bear the AMCA certified ratings seal for sound and air performance.

The QCLBSH fan is available in all configurations with the exception of vertical down (VDO and VDI).

## Standard Product Features

- Belt guard, ventilated (weather cover for VRM)
- Belt tube, sealed
- Two-groove drive minimum w/ 2.0 SF
- Cooling fins on impeller
- Stack cap with fusible link (for VRM)
- Continuously-welded housing
- Bolted access door



## OPTIONAL CONSTRUCTION

### Spark Resistant Construction

Fan applications may involve the handling of fumes or vapors. Such applications require careful consideration by the system designer to insure the safe handling of such gases. Twin City Fan & Blower offers the following classifications of spark resistant construction per AMCA Standard 99-0401. It is the specifier's or the user's responsibility to specify the type of spark resistant construction with full recognition of the potential hazards and the degree of protection required.

**Type B** - The fan shall have a nonferrous impeller and nonferrous rub ring about the opening through which the shaft passes — usually aluminum impeller and rub ring and limited to 200°F. Consult factory for availability.

**Type C** - The fan is constructed so that a shift of the impeller or shaft will not permit two ferrous parts of the fan to rub or strike.





## **Housing**

All fans are constructed of heavy-gauge steel and continuously-welded for strength and rigidity. All fans are provided with punched inlet and outlet flanges as standard.

## **Belt Guard**

Totally enclosed, sealed belt guard is standard on Model QCLB. Totally enclosed, non-sealed belt guard is standard on Models QCLBR and QCLBSH, and Model QCLB when an optional belt tube is provided. Belt guards meet OSHA requirements.

## **Adjustable Motor Base**

A heavy-duty adjustable motor base provides easy and positive adjustment of belt tension.

## **Belt Tube**

A belt tube encloses the belts and drive components, protecting them from the airstream on Models QCLBR and QCLBSH. A belt tube is an optional accessory on Model QCLB.

## **Bolted Access Door**

Bolted access door allows for inspection and maintenance of internal fan components. A hinged access door is an available option.

## **Extended Lube Lines**

Lube lines with grease fittings are extended to the outside of the fan housing on all models. Nylon lines are standard on Model QCLB. Models QCLBR and QCLBSH feature copper lube lines.

## **Straightening Vanes**

Straightening vanes convert tangential velocity pressure into useful static pressure, reducing turbulence and increasing efficiency. Extensive testing of various shapes and locations has resulted in the most efficient aerodynamic design of the straightening vanes.

## **Drain (QCLBR)**

A two inch drain allows drainage of grease to the lowest point of the fan. Drain is located 180° from the motor on vertical fans and at the lowest point of the housing on horizontal fans. A grease box with drain connection is an available option.

## **Universal Mounting Feet**

Fan sizes 90-270 (non-curb mounted) come standard with eight mounting brackets and four universal mounting feet. This allows for easy mounting and motor position changes in the field.

## **Inlet and Outlet Flanges**

Inlet and outlet flanges with prepunched mounting holes are standard on all sizes, providing a bolted connection to ductwork.

## **Clean Out Doors (QCLBR)**

Two cleanout doors are located 180° apart, providing access to the impeller for cleaning.

## **Minimum Two-Groove Drive with 2.0 Service Factor (QCLBSH)**

Drives on Model QCLBSH are provided with a minimum of two grooves and with a service factor of 2.0 or greater to meet UL requirements for smoke control systems. The bearing cover plate can be removed to gain full access to the shaft, bearings and fan sheave.

## **Inner Cylinder**

The inner tube is rigidly constructed to support the shaft and bearings. It is strongly recommended that an access door be provided in the ductwork adjacent to the discharge end of the fan for such service.

## **Bearings**

Standard bearings are selected to exceed the L-10 life of 80,000 hours at the maximum operating speed.

## **Mechanical Run Test & Final Vibration Check**

All fans are assembled for a mechanical run test and final balance prior to shipment. Vibration readings are taken on both fan bearings in the axial, horizontal and vertical directions at the specified speed. Fans are balanced to 0.15 in./sec. peak or less.

## **Shaft**

Shaft diameters sized so that maximum operating speed does not exceed 70% of first critical speed.



## Vertical Construction

Vertical construction is available on sizes 90 through 600.

**Floor or Ceiling Mounted (VUI/VUO/VDI/VDO)** — Four vertical brackets are welded to either end of the fan housing. Bracket location is determined by airflow direction and support details (see drawing below).

**Roof Mounted (VRM)** — A curb cap provides a weathertight seal for roof curb mounted fans. A stack cap and weather cover are also available for the upblast style roof ventilator.

Available Discharges by Model

QCLB	QCLBR	QCLBSH
HBM	HBM	HBM
HCH	HCH	HCH
VDI	N/A	N/A
VDO	N/A	N/A
VUI	VUI	VUI
VUO	VUO	VUO
VRM	VRM	VRM



**VRM**  
*Vertical Roof Mounted*



**VUI**  
*Vertical Discharge Up, Floor Mount Support Brackets On Inlet*



**VUO**  
*Vertical Discharge Up, Ceiling Hung Support Brackets On Outlet*



**VDO**  
*Vertical Discharge Down, Floor Mount Support Brackets On Outlet*



**VDI**  
*Vertical Discharge Down, Ceiling Hung Support Brackets On Inlet*

## Horizontal Construction

Horizontal construction is available on sizes 90 through 600.

**Horizontal Base Mounted (HBM)** — Support legs are provided at each end of the fan for floor mounting.

**Horizontal Ceiling Hung (HCH)** — For duct mounted fans, four suspension clips are welded to the fan casing to allow ceiling suspension using rod hangers. (Motor position E is not available on a Model QCLBR.)

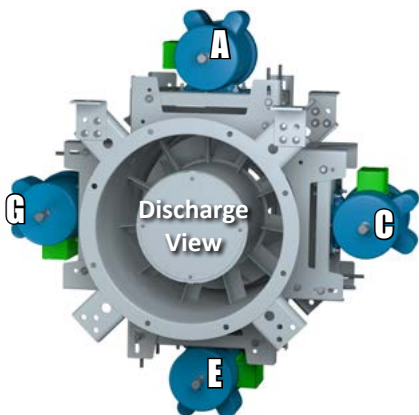
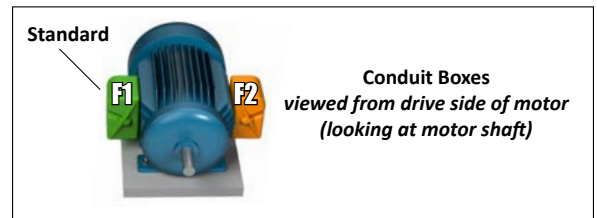

**HCH**  
*Horizontal Ceiling Hung*

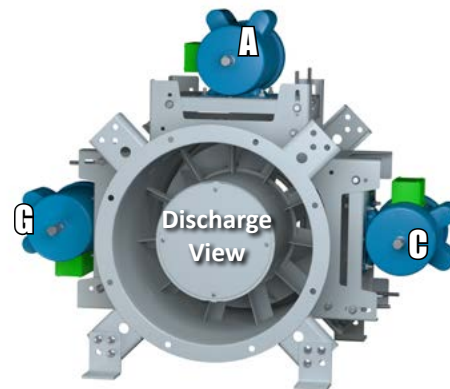

**HBM**  
*Horizontal Base Mounted*

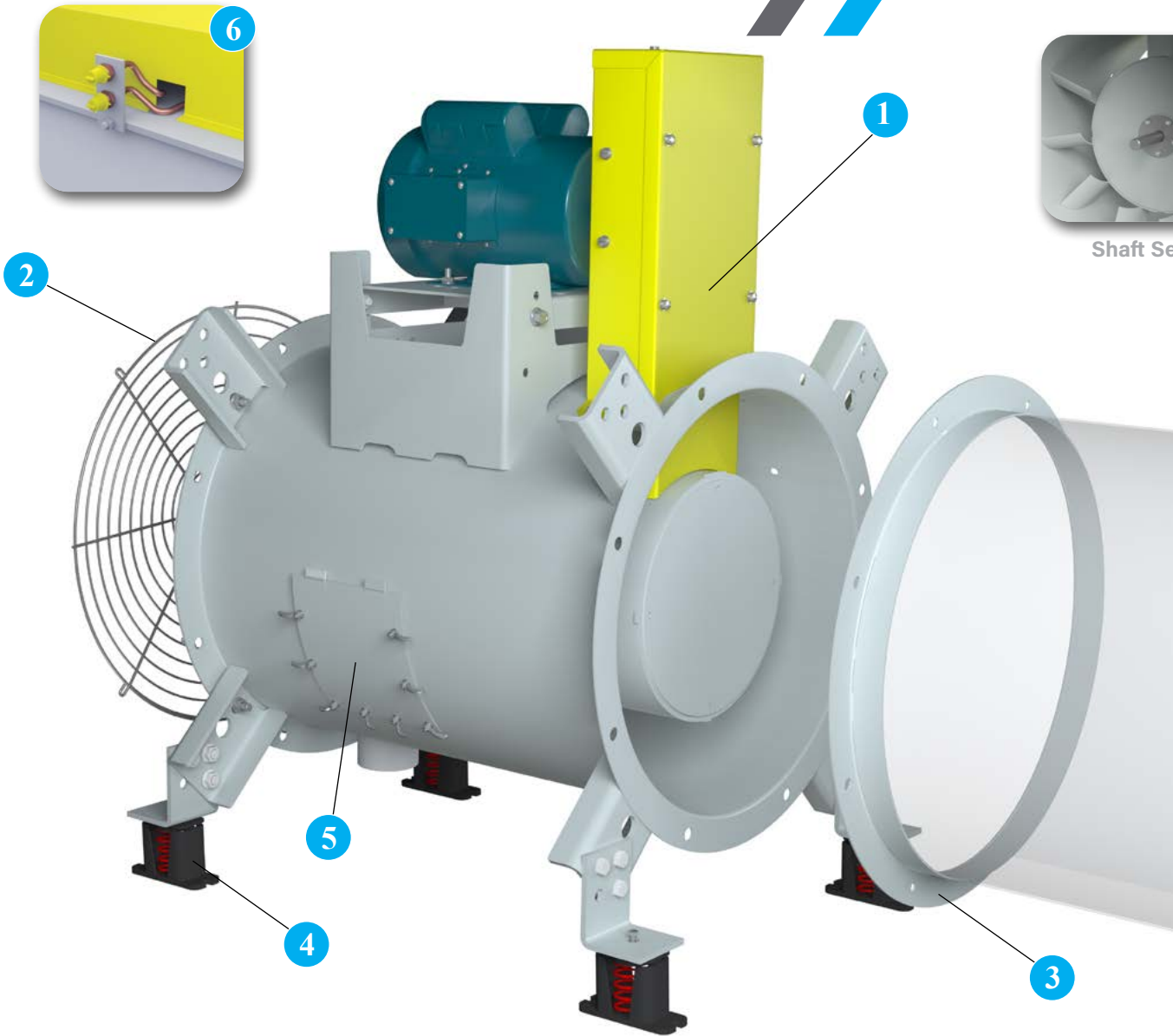

Shaft Seal

- 1 Belt Tube** A belt tube encloses the belts and drive components, protecting them from the airstream. A belt tube is an optional accessory on Model QCLB and standard on Models QCLBR and QCLBSH.
- 2 Inlet/Outlet Screens** Safety screening can be provided for installation in the fan inlet or outlet.
- 3 Companion Flanges** Inlet and outlet companion flanges are available for ease of duct connection. Companion flanges are rolled angle rings punched to match the standard inlet or outlet flange.
- 4 Spring Isolators** Spring type vibration isolation mounts are available to reduce the transmission of fan vibration in 1" or 2" deflection. Spring isolators can be provided for floor mount or ceiling hung orientation.
- 5 Quick Open Access Door** For quick impeller inspection and maintenance. Access doors are specified where examination and cleaning of the fan interior is required.
- 6 Extended Lube Lines** Allow for easy lubrication of bearings on belt driven units without disassembly by extending polyethylene lines from fan bearings to exterior of the guard.

### Other Accessories

- Floor Mounted Rubber Isolators
- Ceiling Hung Spring & Rubber Isolators
- Shaft Seal
- Drain (QCLB & QCLBSH)
- Piezometer Ring
- Thrust Restraints





- 1 Weather Cover** For outdoor installations, the weather cover completely encloses the motor and V-belt drive from the elements and is provided with slots for ventilation. Weather covers are available for either horizontal or vertical flow fans. Standard accessory on vertical roof mounted configuration.
- 2 Curb Cap** Attached to the fan's flange for curb mounting. Standard accessory on vertical roof mounted configuration.
- 3 Grease Box** The heavy-gauge galvanized grease box is designed to trap the grease in and allow the water to run off onto the roof.
- 4 Bolted Access Door** Bolted access door allows for inspection and maintenance of internal fan components.
- 5 Stack Cap** Stack caps are provided as a standard accessory on vertical roof mounted configurations. Stack caps feature butterfly type dampers that seal out weather when the fan is shut off. Butterfly dampers on Models QCLB and QCLBR open with airflow (see table 3 on page 12 for minimum flow rates required to open damper blades). Stack caps on Model QCLBSH meet UL 793 requirements, providing a fusible link and spring assembly that forces the discharge butterfly dampers open when the fuse melts at 165°F. Stack caps on QCLBSH meet snow load tests set forth by UL, IRI and SBCCI.
- 6 Magnetic Damper Latches** Magnetic latches are available to hold stack cap butterfly dampers closed when not in operation.

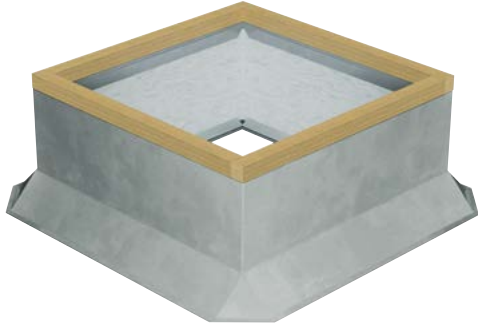

## Canted Roof Curbs

- Constructed of 18-gauge galvanized steel with continuously-welded seams
- Large 3" built-in 45° cant to accommodate roofing material to top of curb. Cant is beveled at corners for better support of roofing material
- Wood nailer (1½") secured to top ledge
- Lined with 1½" fiberglass fire-resistant, sound-absorbing insulation
- Options: Aluminum (16-gauge) construction, burglar security bars, metal liner (galvanized or aluminum), special heights up to 24", single- or double-pitched curbs for sloping roofs



## Self-Flashing & Straight-Sided Roof Curbs

- Constructed of 18-gauge galvanized steel with continuously-welded seams
- Wide base plate (flashing) to insure watertight seal to roof
- Top ledge covered with 3/16" polystyrene gasket (self-flashing) for weather seal and to reduce metal-to-metal conducted noise
- Lined with 1½" fiberglass fire-resistant, sound-absorbing insulation
- Straight-sided roof curbs are similar to the self-flashing curbs, but have flat sides and a wood nailer to allow for field supplied cants and roofing material to be brought up the top of the curb.
- Options: Aluminum (16-gauge) construction, burglar security bars, metal liner (galvanized or aluminum), special heights up to 24", single- or double-pitched curbs for sloping roofs



## Self-Flashing Vented Roof Curbs

### For High Temperature Applications

- Completely assembled unit, easier to install and less expensive than a field constructed curb
- Constructed of 18-gauge galvanized steel with continuously-welded seams and wide base flashing for watertight seal to roof
- Meets NFPA-96 code requirements
- Top ledge covered with 3/16" polystyrene gasket
- Furnished with ventilation slots



## Curb Adapters

- Constructed of heavy-gauge galvanized steel with continuous welded seams
- Top ledge covered with 3/16" polystyrene gasket to reduce metal-to-metal conducted noise and act as a weather seal
- Available in enlarger or reducer (shown) models

Disconnect switches provide positive electrical shutoff during fan cleaning or maintenance.

## **NEMA 1 Disconnect Switch**

A NEMA 1 disconnect switch is available shipped loose for field mounting and wiring or factory mounted and wired with ODP or TEFC motors.



NEMA 1 Disconnect Switch

## **NEMA 3R Disconnect Switch**

A NEMA 3R, rain proof, disconnect is available shipped loose for field mounting and wiring or factory mounted and wired externally.



NEMA 3R Disconnect Switch

## **NEMA 4 Disconnect Switch**

A NEMA 4, water and dust tight, disconnect is available shipped loose for field mounting and wiring or factory mounted and wired externally.



NEMA 4 Disconnect Switch

## **NEMA 7/9 Disconnect Switch**

A NEMA 7/9 disconnect switch is recommended on fans with explosion proof motors. The NEMA 7/9 switch is designed for use with fans operating in hazardous environments. Available shipped loose for field mounting and wiring. (Not shown.)



Table 1. Maximum RPM, Impeller Weights and WR<sup>2</sup> (moment of inertia in lb-ft<sup>2</sup>)

FAN SIZE	LEVEL 1			LEVEL 2		
	MAX. RPM	WEIGHT LB.	WR <sup>2</sup> LB-FT <sup>2</sup>	MAX. RPM	WEIGHT LB.	WR <sup>2</sup> LB-FT <sup>2</sup>
90	3156	8	0.99	4225	9	1.05
122	2577	11	2.03	3450	12	2.15
135	2343	13	2.98	3137	15	3.50
150	2118	16	4.34	2836	18	5.1
165	1933	22	6.9	2588	31	9.9
182	1737	26	10	2326	37	14
200	1578	29	15	2113	46	23
222	1432	34	20	1917	59	34
245	1289	41	29	1725	70	50
270	1171	49	42	1568	84	72
300	1059	67	70	1418	115	121
330	960	78	100	1286	134	171
365	869	119	190	1163	196	313
402	789	142	275	1056	234	452
445	713	172	407	954	282	668
490	644	270	784	863	463	1346
542	586	336	1183	784	577	2030
600	530	405	1743	709	695	2992

Table 2. Bare Fan Weights (lb) (without motor and drive)

FAN SIZE	LEVEL 1	LEVEL 2
90	86	99
122	106	129
135	119	145
150	163	171
165	185	202
182	233	235
200	255	334
222	299	386
245	395	463
270	460	623
300	631	850
330	799	983
365	1085	1235
402	1144	1567
445	1432	1925
490	2140	2388
542	3267	3519
600	3900	4217

Table 3. Minimum CFM Required to Open Stack Cap

FAN SIZE	CFM
90	515
122	770
135	935
150	1051
165	1707
182	2532
200	3527
222	3527
245	4693
270	6574
300	7605
330	8712
365	11158
402	15891
445	15891
490	20904
542	26613
600	34100

Table 4. Temperature and Altitude Density Ratios

AIR TEMP °F	ALTITUDE IN FEET ABOVE SEA LEVEL											
	0	1000	2000	3000	4000	5000	6000	7000	8000	9000	10000	15000
	BAROMETRIC PRESSURE IN INCHES OF MERCURY											
	29.92	28.86	27.82	26.82	25.84	24.90	23.98	23.09	22.22	21.39	20.58	16.89
-50	1.293	1.247	1.201	1.159	1.116	1.076	1.036	0.997	0.960	0.924	0.889	0.729
0	1.152	1.111	1.071	1.032	0.995	0.959	0.923	0.889	0.856	0.824	0.792	0.650
70	1.000	0.964	0.930	0.896	0.864	0.832	0.801	0.772	0.743	0.714	0.688	0.564
100	0.946	0.912	0.880	0.848	0.818	0.787	0.758	0.730	0.703	0.676	0.651	0.534
150	0.869	0.838	0.808	0.770	0.751	0.723	0.696	0.671	0.646	0.620	0.598	0.490
200	0.803	0.774	0.747	0.720	0.694	0.668	0.643	0.620	0.596	0.573	0.552	0.453

## INSTALLATION PHOTOS



Mechanical Room Exhaust



Smoke Emergency Exhaust

Horizontal & Vertical, Size 90 - 270

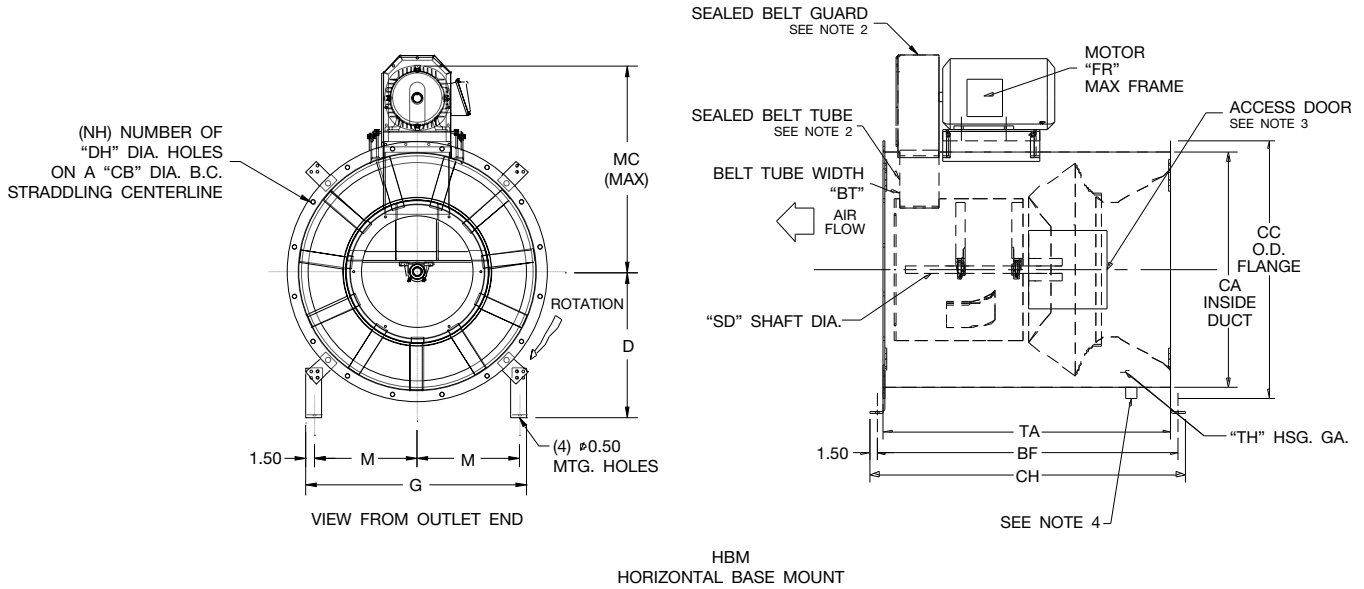

HBM  
HORIZONTAL BASE MOUNT

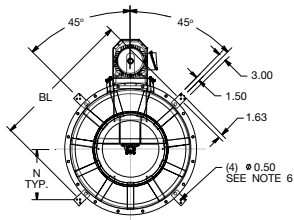

VIEW FROM  
OUTLET END

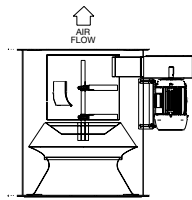

VUI VUO  
DISCHARGE UP  
FLOOR OR CEILING MOUNT

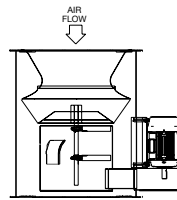

VDO VDI  
DISCHARGE DOWN  
FLOOR OR CEILING MOUNT

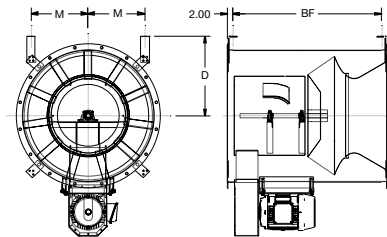

HCH  
HORIZONTAL CEILING HUNG

SIZE	BF	BL	BT	CA	CB	CC	CH	D	DH	FR	G	M	MC	N	NH	SD		TA	TH	
																Level 1	Level 2		Level 1	Level 2
90	22.25	21.00	4.06	13.75	15.25	16.00	25.25	10.69	0.44	184T	19.13	8.06	22.88	7.44	8.00	0.75	0.75	19.44	14.00	12.00
122	25.06	24.25	5.06	16.63	18.50	19.88	28.06	11.81	0.56	184T	21.38	9.19	24.25	8.56	8.00	0.75	0.75	22.25	14.00	12.00
135	26.94	26.13	5.69	18.56	20.38	21.75	29.94	12.50	0.56	184T	22.75	9.88	26.88	9.25	8.00	0.75	0.75	24.13	14.00	12.00
150	30.69	27.88	6.31	20.25	22.13	23.50	33.69	13.13	0.56	213T	23.94	10.50	27.75	9.88	8.00	0.75	0.75	27.88	14.00	12.00
165	33.19	30.13	6.31	22.25	24.38	25.56	36.19	13.88	0.56	213T	25.56	11.25	28.75	10.63	8.00	0.75	1.00	30.38	14.00	12.00
182	36.00	32.50	6.31	24.69	26.75	28.00	39.00	16.75	0.69	215T	27.25	12.13	29.88	11.50	12.00	0.75	1.19	33.19	14.00	12.00
200	37.81	34.88	7.06	27.06	29.13	30.31	40.81	17.56	0.81	254T	28.88	12.94	34.88	12.38	12.00	0.75	1.44	35.00	14.00	12.00
222	39.94	37.88	7.81	30.06	32.13	33.38	42.94	18.63	0.81	256T	31.00	14.00	36.25	13.44	12.00	1.00	1.44	37.13	14.00	12.00
245	43.44	40.88	8.69	33.13	35.13	36.38	46.44	21.69	0.81	256T	33.13	15.06	37.75	14.44	12.00	1.19	1.69	40.63	14.00	12.00
270	47.25	44.25	9.56	36.50	38.50	39.75	50.25	22.88	0.81	284T	35.50	16.25	39.38	15.69	12.00	1.19	1.69	44.44	14.00	12.00

AC1002864B

DIMENSIONS ARE SUBJECT TO CHANGE. CERTIFIED DRAWINGS AVAILABLE ON REQUEST.

NOTES:

1. Fan shown in horizontal shipping position, universal mounting brackets allow for other mounting configurations.
2. Sealed belt guard standard on QCLB, belt tube optional; OSHA type belt guard standard on QCLBR and QCLBSH with belt tube standard.
3. Access door is standard for QCLB & QCLBSH; (2) clean out doors 90° from motor and 180° apart standard on QCLBR.
4. Drain optional on QCLB and QCLBSH, standard on QCLBR
5. (2) Locking collars required on vertical applications.
6. For vertical applications remove support legs.

Horizontal, Size 300 - 600

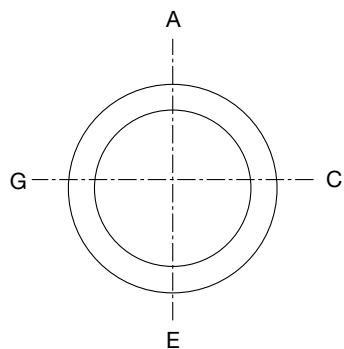
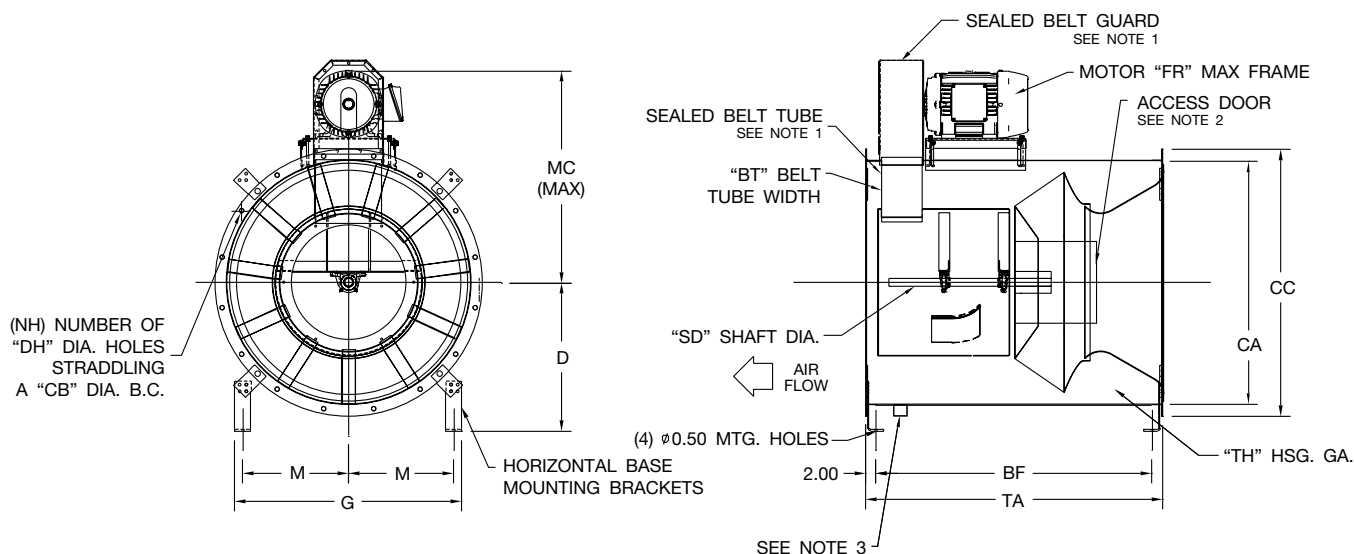

MOTOR LOCATION  
(VIEWED FROM OUTLET)

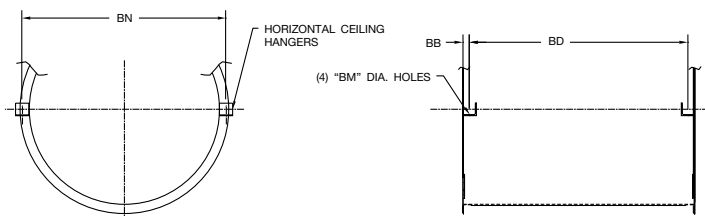

HCH  
HORIZONTAL CEILING HUNG

SIZE	BB	BD	BF	BM	BN	BT	CA	CB	CC	D	DH	FR	G	M	MC	NH	SD		TA	TH	
																	Level 1	Level 2		Level 1	Level 2
300	1.50	46.94	45.94	0.81	43.75	10.69	40.56	43.13	44.88	24.50	0.81	286T	38.81	17.94	41.31	16.00	1.44	1.94	50.06	12.00	10.00
330	1.50	51.50	50.50	0.81	47.88	11.81	44.63	47.25	49.00	27.50	0.81	286T	41.75	19.38	43.25	16.00	1.44	1.94	54.63	12.00	10.00
365	2.00	56.06	56.06	0.81	52.56	12.94	49.38	52.00	53.75	29.19	0.81	324T	45.06	21.06	49.81	16.00	1.44	2.19	60.19	12.00	10.00
402	2.00	62.25	62.25	0.81	57.56	14.44	54.38	57.50	59.75	31.13	0.81	326T	48.94	23.00	52.19	16.00	1.69	2.19	66.38	12.00	10.00
445	2.00	69.06	69.06	0.81	63.38	15.94	60.19	63.25	65.50	34.63	0.81	364T	53.00	25.00	55.00	16.00	1.69	2.44	73.19	12.00	10.00
490	2.00	76.13	76.13	0.81	69.44	17.69	66.25	69.38	73.63	37.81	0.81	365T	57.38	27.19	58.00	24.00	1.94	2.44	80.25	12.00	10.00
542	2.00	85.00	85.00	1.06	76.56	19.56	73.38	77.00	79.75	42.00	0.81	404T	62.75	29.88	71.50	24.00	1.94	2.69	89.13	12.00	10.00
600	2.50	93.63	93.63	1.06	85.38	21.81	81.19	84.75	87.50	44.75	0.81	444T	68.25	32.63	78.44	24.00	2.19	2.94	97.75	12.00	10.00

AC1002865B

DIMENSIONS ARE SUBJECT TO CHANGE. CERTIFIED DRAWINGS AVAILABLE ON REQUEST.

NOTES:

1. Sealed belt guard standard on QCLB, belt tube standard; OSHA type belt guard standard on QCLBR and QCLBSH with belt tube standard.
2. Access door is optional for QCLB and QCLBSH; Two (2) clean out doors 90° from motor and 180° apart standard on QCLBR.
3. Drain optional on QCLB and QCLBSH, standard on QCLBR.

**Vertical, Size 300 - 600**

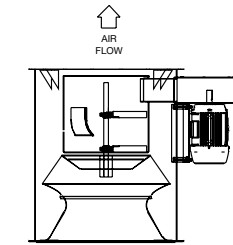
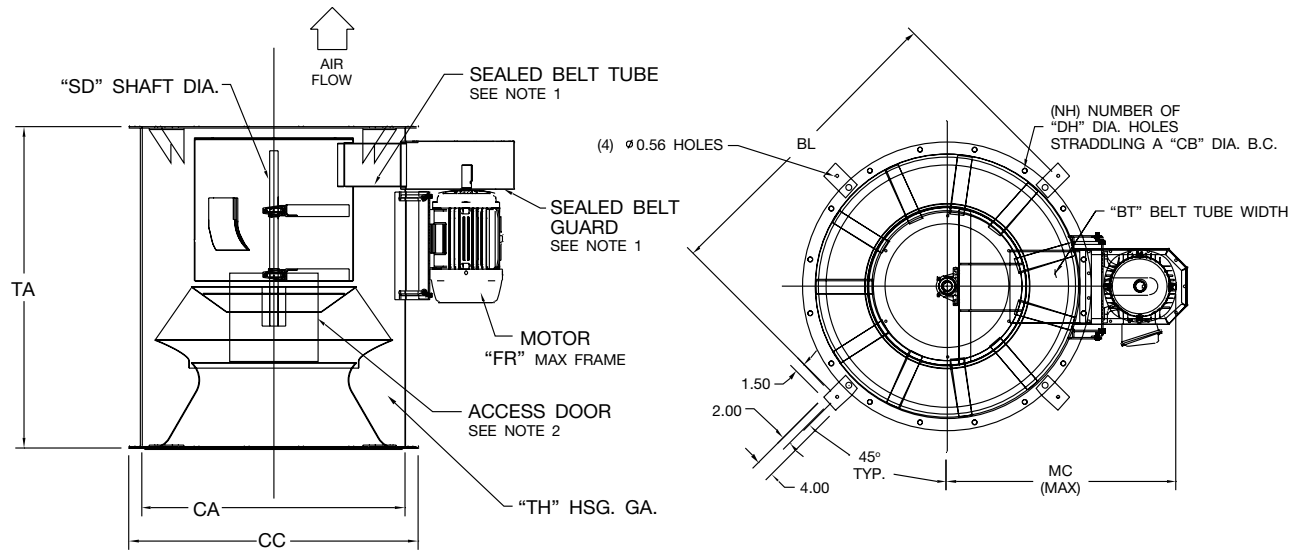

**VUO**  
DISCHARGE UP  
CEILING MOUNT

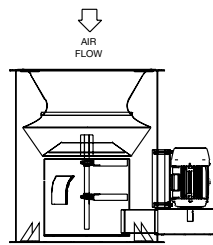

**VDO**  
DISCHARGE DOWN  
FLOOR MOUNT

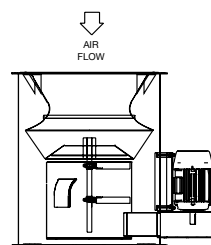

**VDI**  
DISCHARGE DOWN  
CEILING MOUNT

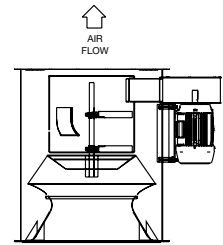

**VUI**  
DISCHARGE UP  
FLOOR MOUNT

SIZE	BL	BT	CA	CB	CC	DH	FR	MC	NH	SD		TA	TH	
										Level 1	Level 2		Level 1	Level 2
300	49.88	10.69	40.56	43.13	44.88	0.81	286T	41.31	16.00	1.44	1.94	50.06	12.00	10.00
330	54.00	11.81	44.63	47.25	49.00	0.81	286T	43.25	16.00	1.44	1.94	54.63	12.00	10.00
365	58.75	12.94	49.38	52.00	53.75	0.81	324T	49.81	16.00	1.44	2.19	60.19	12.00	10.00
402	64.75	14.44	54.38	57.50	59.75	0.81	326T	52.19	16.00	1.69	2.19	66.38	12.00	10.00
445	70.50	15.94	60.19	63.25	65.50	0.81	364T	55.00	16.00	1.69	2.44	73.19	12.00	10.00
490	78.63	17.69	66.25	69.38	73.63	0.81	365T	57.94	24.00	1.94	2.44	80.25	12.00	10.00
542	84.75	19.56	73.38	77.00	79.75	0.81	404T	71.50	24.00	1.94	2.69	89.13	12.00	10.00
600	92.50	21.81	81.19	84.75	87.50	0.81	444T	78.44	24.00	2.19	2.94	97.75	12.00	10.00

AC1002866B

DIMENSIONS ARE SUBJECT TO CHANGE. CERTIFIED DRAWINGS AVAILABLE ON REQUEST.

**NOTES:**

1. Sealed belt guard standard on QCLB, belt tube optional; OSHA type belt guard standard on QCLBR and QCLBSH with belt tube standard.
2. Access door is standard for QCLB and QCLBSH; Two (2) clean out doors 90° from motor and 180° apart standard on QCLBR.
3. Two (2) locking collars required on vertical applications.
4. For vertical applications remove support legs.

**Vertical Roof Mounted, Size 90 - 600**

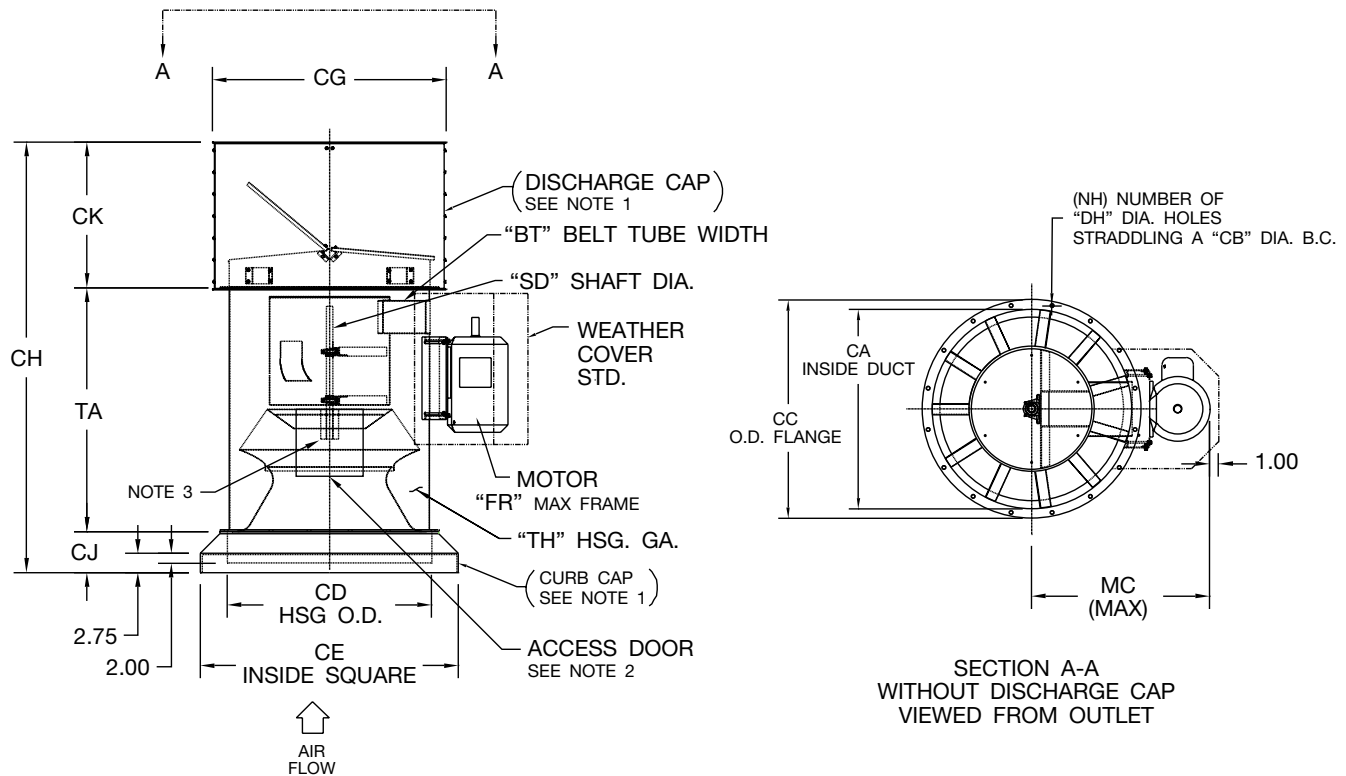

SIZE	BT	CA	CB	CC	CD	CE	CG	CH	CJ	CK	DH	FR	MC	NH	SD		TA	TH	
															Level 1	Level 2		Level 1	Level 2
90	4.06	13.75	15.25	16.00	14.00	17.06	21.06	40.69	5.00	16.25	0.44	184T	22.88	8.00	0.75	0.75	19.44	14.00	12.00
122	5.06	16.63	18.50	19.88	16.88	23.75	23.25	45.13	5.63	17.25	0.56	184T	24.25	8.00	0.75	0.75	22.25	14.00	12.00
135	5.69	18.56	20.38	21.75	18.81	25.38	25.31	48.25	5.88	18.25	0.56	184T	26.94	8.00	0.75	0.75	24.13	14.00	12.00
150	6.31	20.25	22.13	23.50	20.50	27.38	28.63	53.63	6.00	19.75	0.56	213T	27.75	8.00	0.75	0.75	27.88	14.00	12.00
165	6.31	22.25	24.38	25.56	22.56	30.88	28.63	56.44	6.31	19.75	0.56	213T	28.75	8.00	0.75	1.00	30.38	14.00	12.00
182	6.31	24.69	26.75	28.00	24.88	34.88	32.00	61.31	6.63	21.50	0.69	215T	29.94	12.00	0.75	1.19	33.19	14.00	12.00
200	7.06	27.06	29.13	30.31	27.25	37.88	35.00	64.75	6.75	23.00	0.81	254T	34.88	12.00	0.75	1.44	35.00	14.00	12.00
222	7.81	30.06	32.13	33.38	30.25	40.38	38.13	68.63	6.75	24.75	0.81	256T	36.25	12.00	1.00	1.44	37.13	14.00	12.00
245	8.69	33.13	35.13	36.38	33.31	43.38	41.38	74.13	7.00	26.50	0.81	256T	37.75	12.00	1.19	1.69	40.63	14.00	12.00
270	9.56	36.50	38.50	39.75	36.69	46.75	44.38	79.94	7.25	28.25	0.81	284T	39.38	12.00	1.19	1.69	44.44	14.00	12.00
300	10.69	40.56	43.13	44.88	40.81	51.00	50.63	89.31	7.75	31.50	0.81	286T	41.31	16.00	1.44	1.94	50.06	12.00	10.00
330	11.81	44.63	47.25	49.00	44.88	55.13	52.50	95.38	7.75	33.00	0.81	286T	43.25	16.00	1.44	1.94	54.63	12.00	10.00
365	12.94	49.38	52.00	53.75	49.63	59.88	56.63	102.44	7.75	34.50	0.81	324T	49.81	16.00	1.44	2.19	60.19	12.00	10.00
402	14.44	54.38	57.50	59.75	54.63	64.88	63.25	112.38	8.00	38.00	0.81	326T	52.19	16.00	1.69	2.19	66.38	12.00	10.00
445	15.94	60.19	63.25	65.50	60.44	69.63	69.25	123.19	8.50	41.50	0.81	364T	55.00	16.00	1.69	2.44	73.19	12.00	10.00
490	17.69	66.25	69.38	73.63	66.50	78.00	80.00	129.25	9.00	40.00	0.81	365T	57.94	24.00	1.94	2.44	80.25	12.00	10.00
542	19.56	73.38	77.00	79.75	76.63	88.75	86.50	148.00	9.25	49.63	0.81	404T	71.50	24.00	1.94	2.69	89.13	12.00	10.00
600	21.81	81.19	84.75	87.50	81.44	98.00	100.00	162.50	9.75	55.00	0.81	444T	78.44	24.00	2.19	2.94	97.75	12.00	10.00

AS1002867E

DIMENSIONS ARE SUBJECT TO CHANGE. CERTIFIED DRAWINGS AVAILABLE ON REQUEST.

**NOTES:**

1. Curb cap and stack cap are required.
2. Access door is standard for QCLB and QCLBSH; Two (2) clean out doors 90° from motor and 180° apart standard on QCLBR.
3. Two (2) locking collars required on vertical applications.
4. For vertical applications remove support legs.





## Model QCLB

Fans shall be Model QCLB (standard mixed flow) of the non-overloading design, as manufactured by Twin City Fan & Blower, Minneapolis, Minnesota.

**PERFORMANCE** — Performance ratings shall conform to AMCA Standard 208 (fan energy index), 211 (air performance) and 311 (sound performance). Fans shall be tested in accordance with ANSI/AMCA Standard 210 (air performance) and 300 (sound performance) in an AMCA accredited laboratory. Fans shall be licensed to bear the AMCA certified ratings seal for both sound and air, and fan energy index (FEI). Sound certification shall apply to both inlet and outlet sound power levels.

Fans shall be designed for maximum efficiency. Fans shall have a sharply rising pressure characteristic extending through the operating range and continuing to rise well beyond the efficiency peak to assure quiet and stable operation under all conditions. Horsepower characteristics shall be truly self-limiting and shall reach a peak in the normal selection area.

Model QCLB shall be available UL 705 listed. Fans shall bear a permanently attached nameplate displaying model and serial number of the unit for future identification.

**HOUSING** — Housings shall be cylindrical and welded steel throughout. Inlets shall be fully streamlined. Housings shall be suitably braced to prevent vibration or pulsation. Totally enclosed belt guard shall enclose motor sheave and V-belt drives. Punched inlet and outlet flanges shall be equipped for duct mounting. Extended lube lines shall be provided for ease of lubrication. Model QCLB shall include bolted access door for inspection and maintenance of the impeller.

**IMPELLER** — Fan impellers shall have die-formed single thickness blades designed for maximum efficiency, and quiet and stable operation. Blades shall be continuously-welded to the back plate and impeller cone. Impellers shall be statically and dynamically balanced and the complete fan assembly including motor and drive shall be test balanced at or near the operating speed at the factory prior to shipment.

**SHAFT** — Shafts shall be AISI 1040 or 1045 hot rolled steel, accurately turned, ground, polished and ring-gauged for accuracy. Shafts shall be sized for the first critical speed of at least 1.43 times the maximum speed.

**BEARINGS** — Bearings shall be heavy-duty, grease lubricated, anti-friction ball or roller, self-aligning, pillow block type and selected for a minimum L-10 life of 80,000 hours at the maximum fan RPM. Bearings shall be equipped with extended lubrication lines with grease fittings outside of the fan housing.

**DRIVE** — Motor sheaves shall be cast iron, variable pitch on applications 10 HP and smaller, and fixed pitch on 15 HP and larger.

**FINISH AND COATING** — The entire fan assembly, excluding the shaft, shall be properly washed and pretreated before application of a rust-preventative primer, if called out on the order. After the fan is completely assembled, a finish coat of paint shall be applied to the entire assembly, if called out on the order. The fan shaft shall be coated with a petroleum-based rust protectant.

**FACTORY RUN TEST** — All fans with motors and drives mounted by Twin City Fan & Blower shall be completely assembled and test run as a unit at the specified operating speed prior to shipment. Each impeller shall be statically and dynamically balanced in accordance with ANSI/AMCA 204-96 "Balance Quality and Vibration Levels for Fans" to Fan Application Category BV-3, Balance Quality Grade G6.3. Balance readings shall be taken by electronic type equipment in the axial, vertical and horizontal directions on each of the bearings. Records shall be maintained and a written copy shall be available upon request.

**GUARANTEE** — The manufacturer shall guarantee the workmanship and materials for its QCLB Mixed Flow Fans for at least one (1) year from startup or eighteen (18) months from shipment, whichever occurs first.



## Model QCLBR

Fans shall be Model QCLBR (restaurant) of the non-overloading design, as manufactured by Twin City Fan & Blower, Minneapolis, Minnesota.

**PERFORMANCE** — Performance ratings shall conform to AMCA Standard 208 (fan energy index), 211 (air performance) and 311 (sound performance). Fans shall be tested in accordance with ANSI/AMCA Standard 210 (air performance) and 300 (sound performance) in an AMCA accredited laboratory. Fans shall be licensed to bear the AMCA certified ratings seal for both sound and air, and fan energy index (FEI). Sound certification shall apply to both inlet and outlet sound power levels.

Fans shall be designed for maximum efficiency. Fans shall have a sharply rising pressure characteristic extending through the operating range and continuing to rise well beyond the efficiency peak to assure quiet and stable operation under all conditions. Horsepower characteristics shall be truly self-limiting and shall reach a peak in the normal selection area.

Model QCLBR shall be UL 705 Supplement SC (formerly UL 762) listed for the exhaust of grease-laden air. Fans shall bear a permanently attached nameplate displaying model and serial number of the unit for future identification.

**HOUSING** — Housings shall be cylindrical and welded steel throughout. Inlets shall be fully streamlined. Housings shall be suitably braced to prevent vibration or pulsation. Totally enclosed belt guard shall enclose motor sheave and V-belt drives. Punched inlet and outlet flanges shall be equipped for duct mounting. Extended lube lines shall be provided for ease of lubrication. Model QCLBR shall include a belt tube, 2 impeller cleanout doors (located 180° apart) for inspection and maintenance of the impeller and a 2" drain.

**IMPELLER** — Fan impellers shall have die-formed single thickness blades designed for maximum efficiency, and quiet and stable operation. Blades shall be continuously-welded to the back plate and impeller cone. Impellers shall be statically and dynamically balanced and the complete fan assembly including motor and drive shall be test balanced at or near the operating speed at the factory prior to shipment. Impellers on model QCLBR shall have cooling fins to draw cool air over shaft and bearings.

**SHAFT** — Shafts shall be AISI 1040 or 1045 hot rolled steel, accurately turned, ground, polished and ring-gauged for accuracy. Shafts shall be sized for the first critical speed of at least 1.43 times the maximum speed.

**BEARINGS** — Bearings shall be heavy-duty, grease lubricated, anti-friction ball or roller, self-aligning, pillow block type and selected for a minimum L-10 life of 80,000 hours at the maximum fan RPM. Bearings shall be equipped with extended lubrication lines with grease fittings outside of the fan housing.

**DRIVE** — Motor sheaves shall be cast iron, variable pitch on applications 10 HP and smaller, and fixed pitch on 15 HP and larger.

**FINISH AND COATING** — The entire fan assembly, excluding the shaft, shall be properly washed and pretreated before application of a rust-preventative primer, if called out on the order. After the fan is completely assembled, a finish coat of paint shall be applied to the entire assembly, if called out on the order. The fan shaft shall be coated with a petroleum-based rust protectant.

**FACTORY RUN TEST** — All fans with motors and drives mounted by Twin City Fan & Blower shall be completely assembled and test run as a unit at the specified operating speed prior to shipment. Each impeller shall be statically and dynamically balanced in accordance with ANSI/AMCA 204-96 "Balance Quality and Vibration Levels for Fans" to Fan Application Category BV-3, Balance Quality Grade G6.3. Balance readings shall be taken by electronic type equipment in the axial, vertical and horizontal directions on each of the bearings. Records shall be maintained and a written copy shall be available upon request.

**GUARANTEE** — The manufacturer shall guarantee the workmanship and materials for its QCLBR Mixed Flow Fans for at least one (1) year from startup or eighteen (18) months from shipment, whichever occurs first.



## Model QCLBSH

Fans shall be Model QCLBSH (smoke and heat) of the non-overloading design, as manufactured by Twin City Fan & Blower, Minneapolis, Minnesota.

**PERFORMANCE** — Performance ratings shall conform to AMCA Standard 208 (fan energy index), 211 (air performance) and 311 (sound performance). Fans shall be tested in accordance with ANSI/AMCA Standard 210 (air performance) and 300 (sound performance) in an AMCA accredited laboratory. Fans shall be licensed to bear the AMCA certified ratings seal for both sound and air, and fan energy index (FEI). Sound certification shall apply to both inlet and outlet sound power levels.

Fans shall be designed for maximum efficiency. Fans shall have a sharply rising pressure characteristic extending through the operating range and continuing to rise well beyond the efficiency peak to assure quiet and stable operation under all conditions. Horsepower characteristics shall be truly self-limiting and shall reach a peak in the normal selection area.

Model QCLBSH shall be UL listed for Smoke Control Systems (500°F for 4 hours and 1000°F for 15 minutes). Fans shall bear a permanently attached nameplate displaying model and serial number of the unit for future identification.

**HOUSING** — Housings shall be cylindrical and welded steel throughout. Inlets shall be fully streamlined. Housings shall be suitably braced to prevent vibration or pulsation. Totally enclosed belt guard shall enclose motor sheave and V-belt drives. Punched inlet and outlet flanges shall be equipped for duct mounting. Extended lube lines shall be provided for ease of lubrication. Model QCLBSH shall include a belt tube for the protection of belts and drive components from the airstream and bolted access door.

**IMPELLER** — Fan impellers shall have die-formed single thickness blades designed for maximum efficiency, and quiet and stable operation. Blades shall be continuously-welded to the back plate and impeller cone. Impellers shall be statically and dynamically balanced and the complete fan assembly including motor and drive shall be test balanced at or near the operating speed at the factory prior to shipment. Impellers on model QCLBSH shall have cooling fins to draw cool air over shaft and bearings.

**SHAFT** — Shafts shall be AISI 1040 or 1045 hot rolled steel, accurately turned, ground, polished and ring-gauged for accuracy. Shafts shall be sized for the first critical speed of at least 1.43 times the maximum speed.

**BEARINGS** — Bearings shall be heavy-duty, grease lubricated, anti-friction ball or roller, self-aligning, pillow block type and selected for a minimum L-10 life of 80,000 hours at the maximum fan RPM. Bearings shall be equipped with extended lubrication lines with grease fittings outside of the fan housing.

**DRIVE** — Motor sheaves shall be cast iron, variable pitch on applications 10 HP and smaller, and fixed pitch on 15 HP and larger. Model QCLBSH shall be equipped with a two-groove drive minimum.

**FINISH AND COATING** — The entire fan assembly, excluding the shaft, shall be properly washed and pretreated before application of a rust-preventative primer, if called out on the order. After the fan is completely assembled, a finish coat of paint shall be applied to the entire assembly, if called out on the order. The fan shaft shall be coated with a petroleum-based rust protectant.

**FACTORY RUN TEST** — All fans with motors and drives mounted by Twin City Fan & Blower shall be completely assembled and test run as a unit at the specified operating speed prior to shipment. Each impeller shall be statically and dynamically balanced in accordance with ANSI/AMCA 204-96 "Balance Quality and Vibration Levels for Fans" to Fan Application Category BV-3, Balance Quality Grade G6.3. Balance readings shall be taken by electronic type equipment in the axial, vertical and horizontal directions on each of the bearings. Records shall be maintained and a written copy shall be available upon request.

**GUARANTEE** — The manufacturer shall guarantee the workmanship and materials for its QCLBSH Mixed Flow Fans for at least one (1) year from startup or eighteen (18) months from shipment, whichever occurs first.

# INDUSTRIAL PROCESS AND COMMERCIAL VENTILATION SYSTEMS

CENTRIFUGAL FANS | UTILITY SETS | PLENUM & PLUG FANS | INLINE CENTRIFUGAL FANS  
MIXED FLOW FANS | TUBEAXIAL & VANEAXIAL FANS | WALL MOUNTED FANS | ROOF VENTILATORS  
CENTRIFUGAL ROOF & WALL EXHAUSTERS | CEILING VENTILATORS | GRAVITY VENTILATORS | DUCT BLOWERS  
RADIAL BLADED FANS | RADIAL TIP FANS | HIGH EFFICIENCY INDUSTRIAL FANS | PRESSURE BLOWERS  
LABORATORY EXHAUST FANS | FILTERED SUPPLY FANS | MANCOOLERS | FIBERGLASS FANS | CUSTOM FANS



**TWIN CITY FAN & BLOWER**  
[WWW.TCF.COM](http://WWW.TCF.COM)

5959 TRENTON LANE N. | MINNEAPOLIS, MN 55442 | PHONE: 763-551-7600 | FAX: 763-551-7601

©2009-2024 Twin City Fan Companies, Ltd., Minneapolis, MN. All rights reserved. Catalog illustrations cover the general appearance of Twin City Fan & Blower products at the time of publication and we reserve the right to make changes in design and construction at any time without notice.