

# Sidewall Propeller Fans

## Model AER-M

Direct Drive - Efficient and Reliable Supply and Exhaust Fans



Greenheck's wall axial fans are designed to provide efficient and reliable operation for commercial and industrial process applications. We manufacture our products with state-of-the-art equipment and undergo quality control testing to ensure trouble-free start-up and operation. Model AER-M is an excellent choice for exhaust and supply air applications.

## Benefits

- Completely selectable in Greenheck's CAPS® program
- Improved efficiency with housing and propeller design
- Flexible design for supply or exhaust arrangements
- Suitable for wall-mounted clean air applications
- All fans are tested to ensure vibration-free operation
- AMCA licensed for Air & Sound performance



Greenheck India Private Ltd. certifies that the model AER-M direct drive fans shown herein are licensed to bear the AMCA seal. The ratings shown are based on tests and procedures performed in accordance with AMCA Publication 211 and Publication 311 and comply with the requirements of the AMCA Certified Ratings Program.

Certified data may be found in Greenheck's Computer Aided Product Selection program CAPS®



## Standard Construction, Features & Options

- Performance up to 49,390 cmh (29,070 cfm) and 610 Pa (2.45 in. wg)
- Corrosion-resistant galvanized construction
- Available in a range of sizes between 500 to 900 mm (20 to 36 in.)
- Direct drive

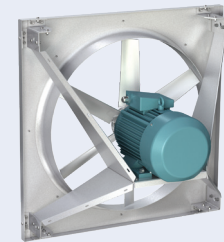

### Vari-Green® Motors

Optional Vari-Green® electronically commutated (EC) motors provide the efficiency and control you need in energy-conscious facilities allowing you to increase or decrease fan capacity based on ventilation requirements.



## AER-M Direct Drive



### Drive Frame

- Galvanized steel with bolted construction
- Prepunched mounting holes
- Formed flanges

### Propeller

- Heavy-duty cast aluminum propeller (AER-M direct drive 500 to 900 mm diameters, (20 to 36 inches)
- Fabricated steel propeller (AER-M direct drive 500 to 630 mm diameters, (20 to 24 inches)
- All propellers are statically and dynamically balanced

## Model AER-M Direct Drive Propeller Fan

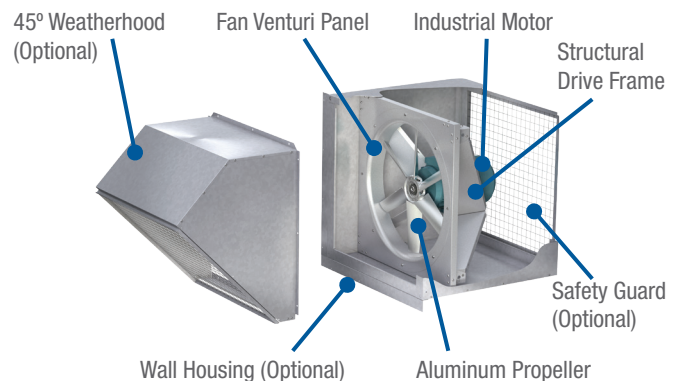



Sidewall propeller fans are ideal for high volumes of air and low pressure requirements. Typical installations push supply air into the space or pull exhaust air with wall-mounted propeller fans.

## Typical Applications

- **Data centers:** Supply or exhaust air for cooling the servers
- **Warehouses:** Supply or exhaust air
- **Manufacturing:** Supply or exhaust air comfort cooling and process exhaust

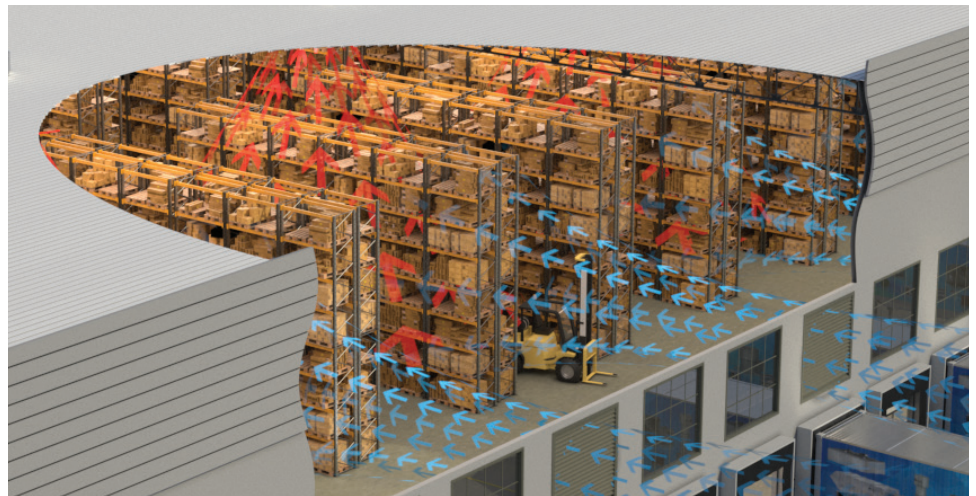

Outside wall installation  
(Shown as supply).

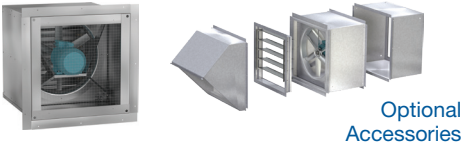

Inside wall installation  
(Shown as exhaust).

Mounting Option	Description
<p><b>Standard Wall Mounting</b></p> 	<p>Fan can be mounted directly to a wall.</p>
<p><b>Wall Housing</b></p>  <p style="text-align: right; font-size: small;">Optional Accessories</p>	<p>The wall housing is the easiest and most flexible way to mount the sidewall propeller fan and all of its accessories.</p>

## Standard Wall Mounting

The split drawing (below) illustrates the typical ways of mounting fans directly to the wall when a wall housing or collar is not used.

For exhaust fans, there is a minimum dimension (M) which must be maintained between the propeller and damper, or guard to achieve optimum performance (failure to meet this minimum dimension will result in loss of fan performance, increased noise and shortened fan and damper life). There is also a minimum required wall opening dimension (W.O.) to allow the venturi to fit into the wall opening.

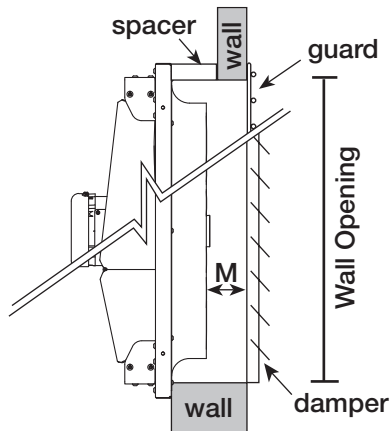

The chart provides the minimum “M” and wall opening dimensions.

Fan Size	M	Wall Opening (Fan Only)
500 (20)	305 (12)	572 (22½)
630 (24)	330 (13)	673 (26½)
800 (30)	330 (13)	826 (32½)
900 (36)	356 (14)	978 (38½)

All dimensions given in millimeters (in).

This installation may require a spacer (by others) between the fan and wall to achieve the minimum “M” dimension.

Fans can mount directly to a wall only if the wall is of sufficient thickness to meet the minimum “M” dimension as shown in the illustration. If mounting to a wall through the face of the fan panel, holes must be appropriately drilled where required.

## Wall Housing Mounting

Wall housings are the safest, most efficient and sturdy platform for mounting sidewall propeller fans and their optional accessories. Wall housings allow for a wide range of mounting arrangements to meet specific applications. It is constructed of galvanized steel with heavy-gauge mounting flanges and prepunched mounting holes. Protective guards of welded steel wire completely protect the drive side of the wall housing.

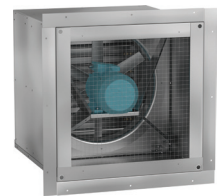

The wall housing is designed to reduce installation time and provide maximum installation flexibility. Attached accessories such as backdraft dampers, guards and weatherhoods may mount to either end. As a result, a wide variety of configurations are available to accommodate the needs of the system designer.

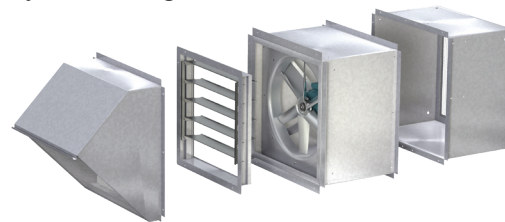

Fan Size	M	Wall Opening (With accessories)
500 (20)	305 (12)	694 (27.3)
630 (24)	330 (13)	845 (33.3)
800 (30)	330 (13)	1000 (39.4)
900 (36)	356 (14)	1153 (45.4)

All dimensions given in millimeters (in).

## Water Ingress and Mitigation

- Fans installed to supply air to a building risk supplying moisture to the building.
- The amount of water captured depends on air velocity, water droplet size, length of the event, wind strength and wind direction. Because of these variables, some degree of water entrainment can occur. Exercise caution when supplying air with a sidewall propeller fan.
- Weatherhoods and louvers are recommended to reduce the likelihood of water entering a building through the fan opening.
- Installing the fan with a slight slope toward the outside will minimize water ingress to the building.
- Air velocities below 2.5 m/s (500 ft/min) reduce the risk of rain ingress; however snow can be captured at much lower rates.
- Consider mounting under an eave with a rain gutter if fan will be mounted near the roofline.

## Dampers

Volume control dampers are available for exhaust or supply configurations and may be used alone or in conjunction with the wall housing. Constructed with heavy galvanized steel frames and blades, model VCD dampers handle higher air volumes than the standard backdraft damper. Dampers are available in standard leakage (VCD-20) configurations. Actuators are available in 220, 230 or 240 volt single phase.

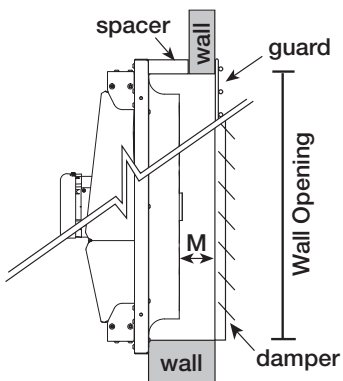

VCD-20

Damper Layout	Damper Type	Description															
<p>Exhaust or Supply - Motorized</p> 	<p><b>Model VCD-20</b> Standard leakage</p> <table border="1"> <thead> <tr> <th>Fan Size</th> <th>M</th> <th>Wall Opening</th> </tr> </thead> <tbody> <tr> <td>500 (20)</td> <td>305 (12)</td> <td>694 (27.3)</td> </tr> <tr> <td>630 (24)</td> <td>330 (13)</td> <td>845 (33.3)</td> </tr> <tr> <td>800 (30)</td> <td>330 (13)</td> <td>1000 (39.4)</td> </tr> <tr> <td>900 (36)</td> <td>356 (14)</td> <td>1153 (45.4)</td> </tr> </tbody> </table> <p>All dimensions given in millimeters (in).</p>	Fan Size	M	Wall Opening	500 (20)	305 (12)	694 (27.3)	630 (24)	330 (13)	845 (33.3)	800 (30)	330 (13)	1000 (39.4)	900 (36)	356 (14)	1153 (45.4)	<p>The VCD damper has the parallel blade set-up and a prepunched mounting flange that provides a flush exterior appearance.</p>
Fan Size	M	Wall Opening															
500 (20)	305 (12)	694 (27.3)															
630 (24)	330 (13)	845 (33.3)															
800 (30)	330 (13)	1000 (39.4)															
900 (36)	356 (14)	1153 (45.4)															

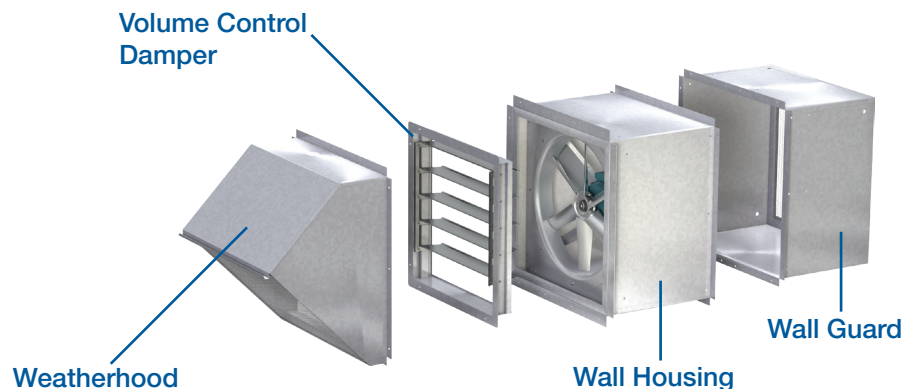

# Mounting Options Flush Exterior

Wall mount propeller fans can be oriented horizontally with motor access from the interior or exterior of the building.

## Interior of Building Access - Damper Outside

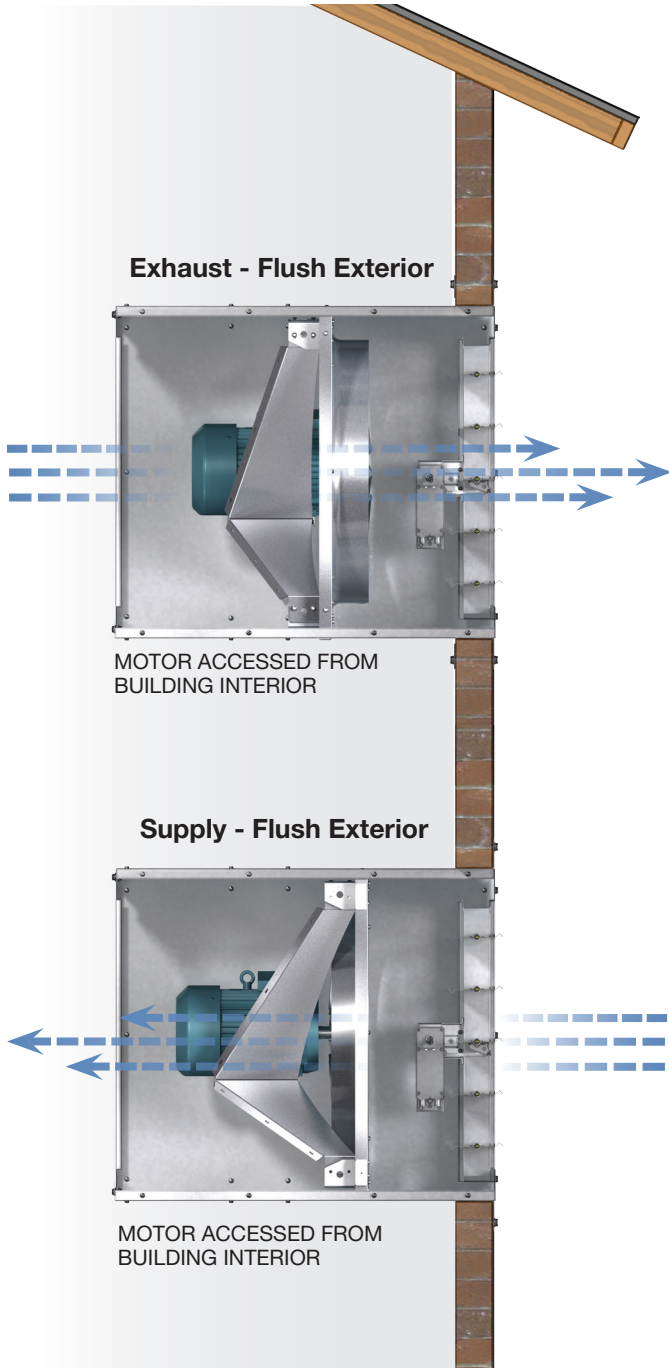

## Exterior of Building Access - Damper Inside

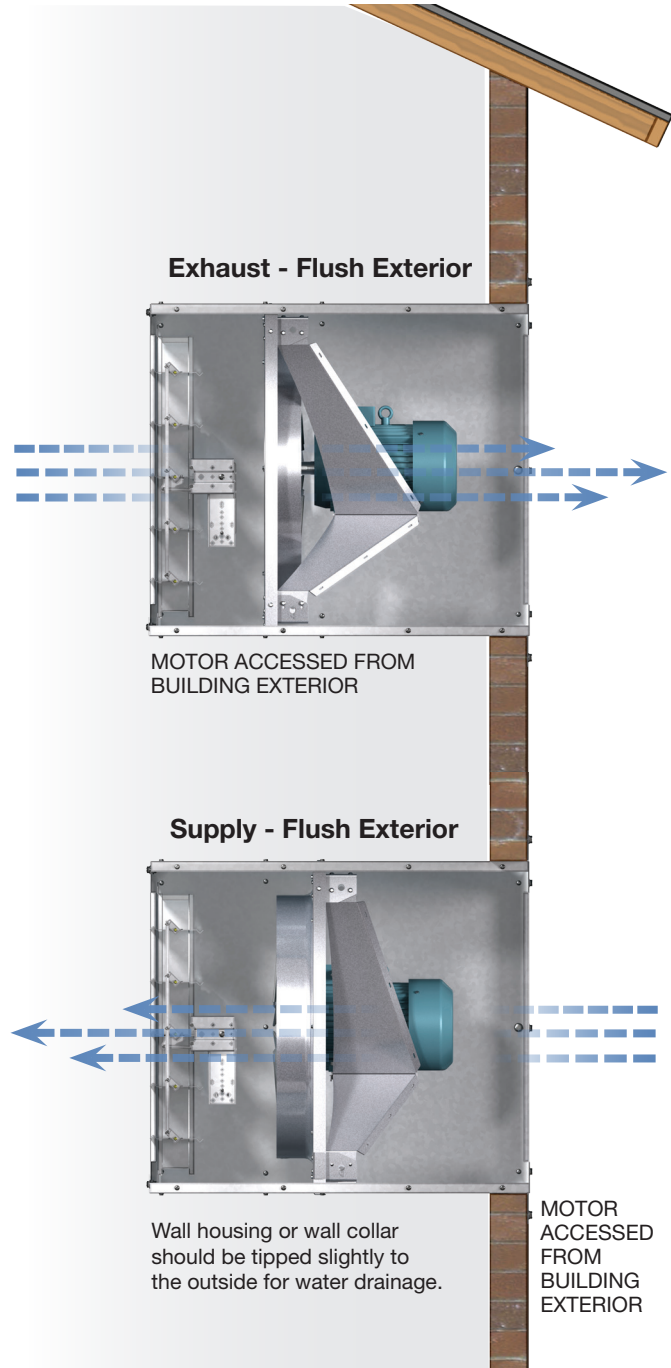

## Interior of Building Access - Damper Outside

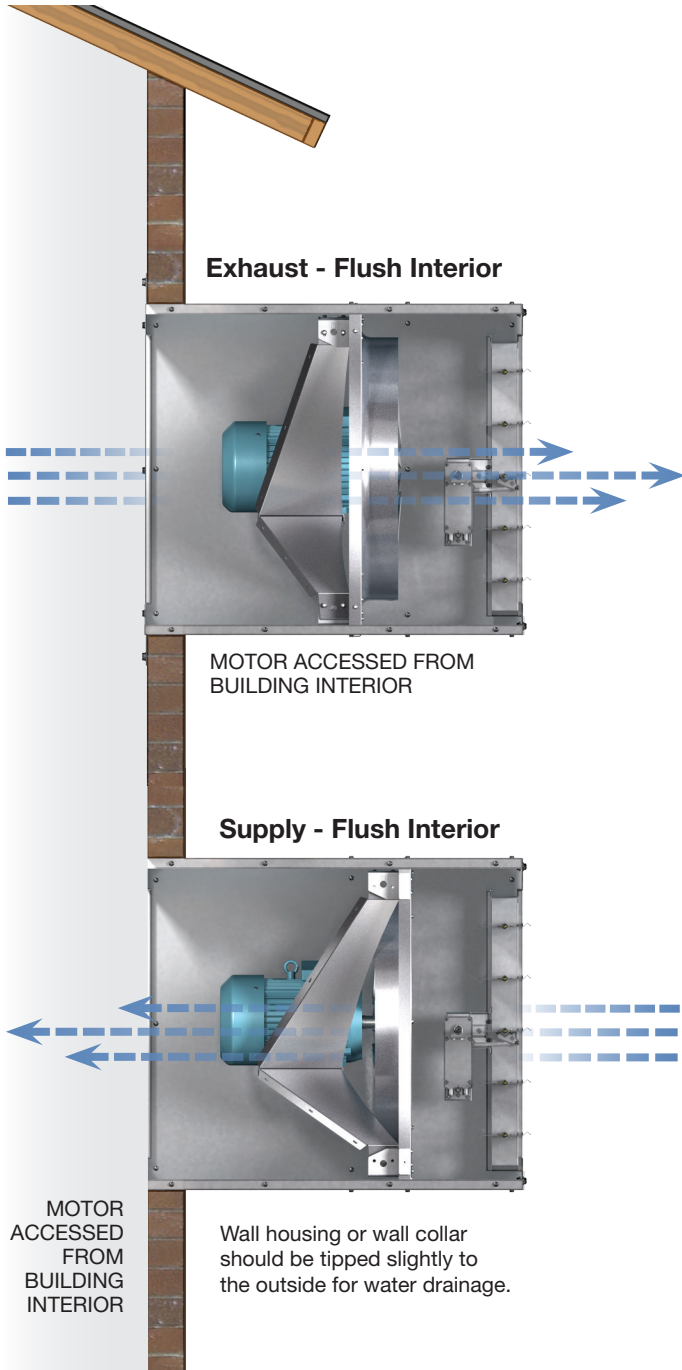

## Exterior of Building Access - Damper Inside

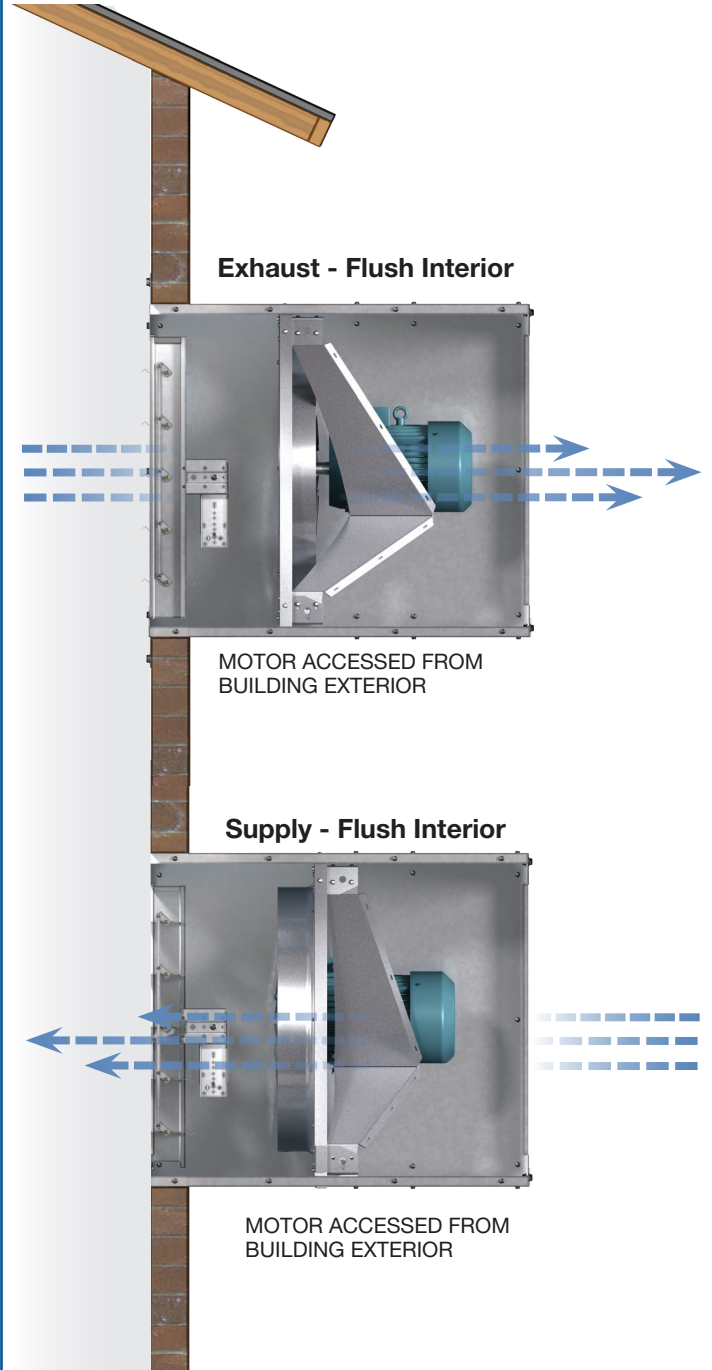

# Performance and Dimensions

## Performance

Model	Max. Motor kW (HP)	Max. Fan RPM	Max. CMH (CFM)	Max. Static Pressure Pa (in. wg)
<b>Supply and Exhaust</b>				
AER-M500	1.1 (1.5)	1750	12,013 (7,071)	398 (1.60)
AER-M630	2.2 (3)	1750	20,994 (12,357)	510 (2.05)
AER-M800	2.2 (3)	1750	28,991 (17,064)	528 (2.12)
AER-M900	5.5 (7.5)	1750	49,390 (29,070)	610 (2.45)

## Dimensions

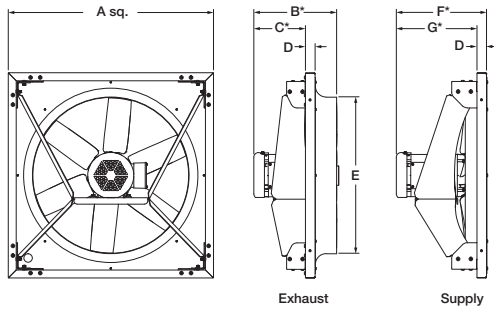

Fan Size	A	B*		C*		D	E	F*		G*		Damper Size Sq.
		Min.	Max.	Min.	Max.			Min.	Max.	Min.	Max.	
500	661 (26)	262 (10.3)	345 (13.6)	137 (5.4)	218 (8.6)	38 (1.5)	517 (20.35)	269 (10.59)	355 (14)	229 (9)	315 (12.4)	559 (22)
630	813 (32)	262 (10.3)	404 (15.9)	141 (5.6)	283 (11.14)	38 (1.5)	619 (24.37)	269 (10.59)	416 (16.38)	229 (9)	376 (14.8)	660 (26)
800	968 (38)	301 (11.85)	404 (15.9)	157 (6.2)	260 (10.24)	38 (1.5)	771 (30.35)	308 (12.13)	416 (16.38)	268 (10.55)	376 (14.8)	813 (32)
900	1120 (44)	301 (11.85)	537 (21.14)	138 (5.43)	374 (14.72)	38 (1.5)	924 (36.398)	308 (12.13)	550 (21.65)	268 (10.55)	510 (20.1)	965 (38)

All dimensions given in millimeters (in). \*Varies with motor selection.

## Model Number

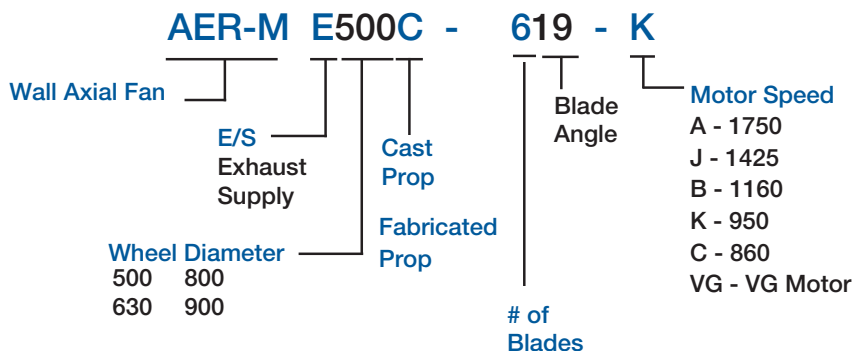

International  
00.INT.2036 R3 11-2025  
Copyright © 2025 Greenheck Fan Corp.

Greenheck India: 201-202, 2nd Floor, Landmark Cyber Park, Sector-67, Gurgaon, Haryana-122018 • www.greenheck.co.in  
Greenheck U.S.A.: P.O. Box 410 • Schofield, WI 54476-0410 • Phone +1 (715) 359-6171 • www.greenheck.com

Greenheck India Private Ltd has been independently audited and confirmed as being in conformity with ISO 9001:2015 and ISO 14001:2015.