

## EFD-437-FL

(standard)

\*Louver dimensions furnished approximately 1/2" (13) undersize.

## Options

### ■ Factory finish:

- High Performance Fluoropolymer
- Baked Enamel
- Clear Anodize
- Prime Coat
- Integral Color Anodize

### ■ Frame Options:

- 1-1/2" (38) flange frame

### ■ Alternate bird or insect screens

### ■ Insulated or non-insulated blank-off panels

### ■ Filter racks

### ■ Head and/or sill flashing

### ■ Burglar bars

### ■ Net OD (actual size)



### Certified Ratings:

Pottorff certifies that the model EFD-437-FL shown herein is licensed to bear the AMCA seal. The ratings shown are based on test and procedures performed in accordance with AMCA Publication 511 and comply with the requirements of the AMCA Certified Ratings Program. The AMCA Certified Ratings seal applies to air performance and water penetration ratings.



**IMPACT RESISTANT LOUVER**  
*Basic Protection*

See [www.AMCA.org](http://www.AMCA.org) for all certified or listed products

This label does not signify AMCA airflow performance certification.

The EFD-437-FL louver is designed to prevent water penetration in non-wind-driven rain applications by collecting water in frame and blade gutters and channeling it into downspouts and away from airflow paths. The design is engineered and tested to withstand extreme loads, debris impact, and cyclic fatigue associated with the severe weather effects of hurricanes (Florida Building Code approval No. FL32498). The EFD-437-FL is AMCA 540 listed, making it ideally suited for use in hurricane-prone and wind borne debris regions as per the International Building Code. In addition, the EFD-437-FL is a UL Classified Windstorm Rated Assembly with design pressures up to 250 psf (depending on section size).

## Standard Construction

**Material:** Mill finish 6063 extruded aluminum

**Frame:** 4" deep x 0.081" thick (102 x 2.1) channel

**Blades:** 0.081" (2.1) thick horizontal drainable style

**Screen:** 1/2" x 0.063" (12.7 x 1.6) expanded and flattened aluminum

**Mullion:** Visible

**Minimum Size:** 12" x 12" (305 x 305)

**Maximum Size:**

Single section: 60" x 120" (1524 x 3048)

Multiple section: Unlimited width x 120" (3048)  
60" (1524) x unlimited height

**Shipping Weight (approximate):** 3.5 lbs/ft<sup>2</sup> (26kg/m<sup>2</sup>)

**Installation Hardware:** Standard continuous angles and associated fasteners (anchors to substrate by others - refer to installation instructions)



**5 year warranty**



### Certified Ratings:

Pottorff certifies that the model EFD-437-FL shown herein is approved to bear the AMCA Listing Label. The ratings shown are based on tests and procedures performed in accordance with AMCA publications and comply with the requirements of the AMCA Listing Label Program. The AMCA Listing Label applies to Impact resistance.

**NOTE:** Dimensions in parentheses ( ) are millimeters.  
Information is subject to change without notice or obligation.

# PERFORMANCE

## EFD-437-FL

Extruded Aluminum Louver  
4" deep • 37-1/2" Drainable Blade

### Free Area (ft<sup>2</sup>)

Width (Inches)

Height (Inches)	Width (Inches)									
	12	18	24	30	36	42	48	54	60	
12	0.2	0.4	0.5	0.6	0.8	0.9	1.0	1.1	1.3	
18	0.5	0.7	1.0	1.3	1.5	1.8	2.1	2.3	2.6	
24	0.8	1.2	1.7	2.2	2.6	3.1	3.6	3.9	4.4	
30	1.1	1.7	2.4	3.0	3.7	4.3	5.0	5.4	6.1	
36	1.3	2.1	2.9	3.7	4.5	5.3	6.1	6.7	7.5	
42	1.6	2.6	3.5	4.5	5.4	6.4	7.3	8.1	9.0	
48	1.9	3.1	4.2	5.4	6.5	7.7	8.9	9.7	10.9	
54	2.2	3.5	4.8	6.1	7.4	8.7	10.1	11.0	12.4	
60	2.4	3.9	5.3	6.8	8.2	9.7	11.1	12.2	13.6	
66	2.7	4.4	6.0	7.7	9.3	11.0	12.6	13.8	15.5	
72	3.0	4.9	6.7	8.5	10.3	12.2	14.0	15.3	17.2	
78	3.3	5.3	7.3	9.2	11.2	13.2	15.2	16.6	18.6	
84	3.6	5.7	7.8	10.0	12.1	14.2	16.4	18.0	20.1	
90	3.9	6.2	8.5	10.9	13.2	15.5	17.9	19.6	22.0	
96	4.1	6.6	9.1	11.6	14.1	16.6	19.1	21.0	23.4	
102	4.4	7.0	9.6	12.3	14.9	17.5	20.1	22.1	24.7	
108	4.7	7.5	10.3	13.2	16.0	18.8	21.6	23.8	26.6	
114	5.0	8.0	11.0	14.0	17.0	20.0	23.0	25.3	28.3	
120	5.3	8.4	11.6	14.7	17.9	21.0	24.2	26.6	29.7	

### Design Load (psf)

	Section Height (inches)	Section Width (inches)								
		12	18	24	30	36	42	48	54	60
Single-Section Wide	≤120	250	250	227	182	152	130	114	101	87
	≤72	250	250	227	182	152	130	114	101	87
Multi-Section Wide	84	250	250	213	171	143	122	107	95	86
	96	250	248	187	150	125	107	94	83	75
	102	231	220	166	133	111	95	83	74	67
	120	208	198	149	120	100	86	75	67	60



#### Certified Ratings:

Pottorff certifies that the model EFD-437-FL shown herein is licensed to bear the AMCA seal. The ratings shown are based on test and procedures performed in accordance with AMCA Publication 511 and comply with the requirements of the AMCA Certified Ratings Program. The AMCA Certified Ratings seal applies to air performance and water penetration ratings.

## Ratings

**Free Area:** [48" x 48" (1219 x 1219) unit]: 8.9 ft<sup>2</sup> (0.82 m<sup>2</sup>)  
55.3%

#### Performance @ Beginning Point of Water Penetration

**Free Area Velocity:** 1,029 fpm (5.23 m/s)

**Air Volume Delivered:** 9,105 cfm (4.30 m<sup>3</sup>/s)

**Pressure Loss:** 0.16 in.wg. (39 Pa)

**Velocity @ 0.15 in.wg. Pressure Loss:** 1,012 fpm (5.14 m/s)

**AMCA 540 (impact resistance, Basic protection) listed**

**Florida Building Code Approval (2020-FBC):** No. FL32498

**Tested and qualified per TAS 201, TAS 202, and TAS 203**

**Approved for use within the High Velocity Hurricane Zone (HVHZ)**

**Design Load:** up to 250 psf (12.0 kPa), depending on section size (See back page for section sizes)

## Pressure Loss

(Data corrected to standard air density)

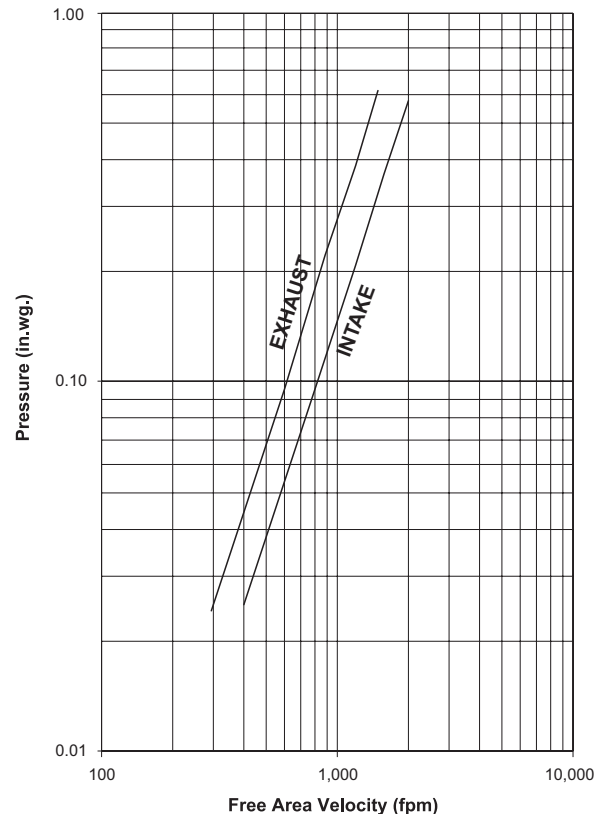

Louver Test Size = 48" x 48" (1219 x 1219)

Pressure loss tested in accordance with Figure 5.5 of AMCA Standard 500-L. Data corrected to standard air density.

# EFD-437-FL

Extruded Aluminum Louver  
4" deep • 37-1/2° Drainable Blade

## Water Penetration

AMCA defines the beginning point of water penetration as the free area velocity at the intersection of a simple linear regression of test data and the line of 0.01 ounces of water per square foot of free area measured through a 48" x 48" louver during a 15 minute period. The AMCA water penetration test provides a method for comparing louver models and designs as to their efficiency in resisting the penetration of rainfall under specific lab conditions. We recommend that intake louvers are selected with a reasonable margin of safety below the beginning point of water penetration in order to avoid unwanted penetration during severe storm conditions.

**Beginning Point of Water Penetration = 1,029 fpm**

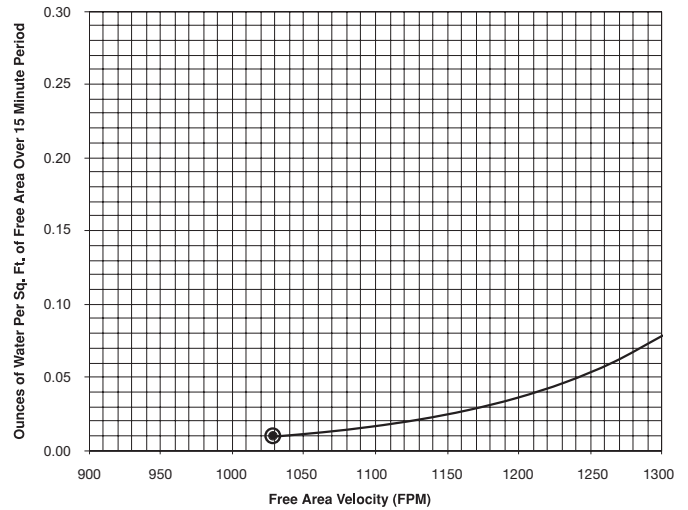

## Attributes

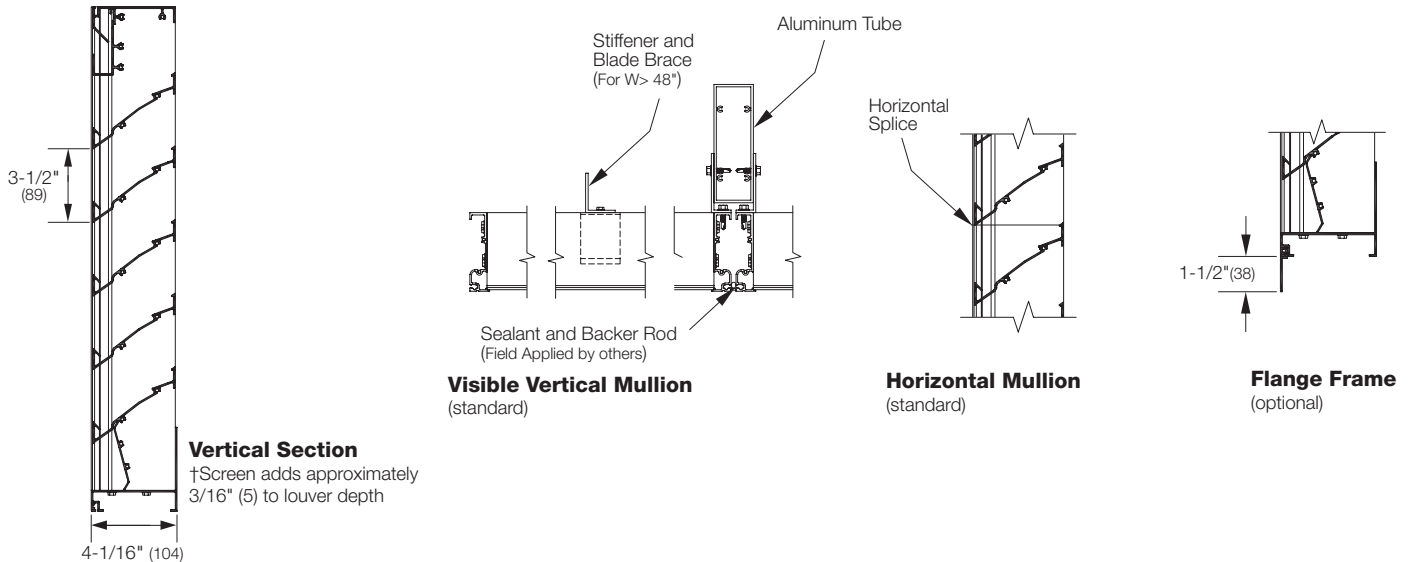

## Supplemental Options

