

# Laboratory Exhaust Systems

## Vektor<sup>®</sup>-H

High Plume

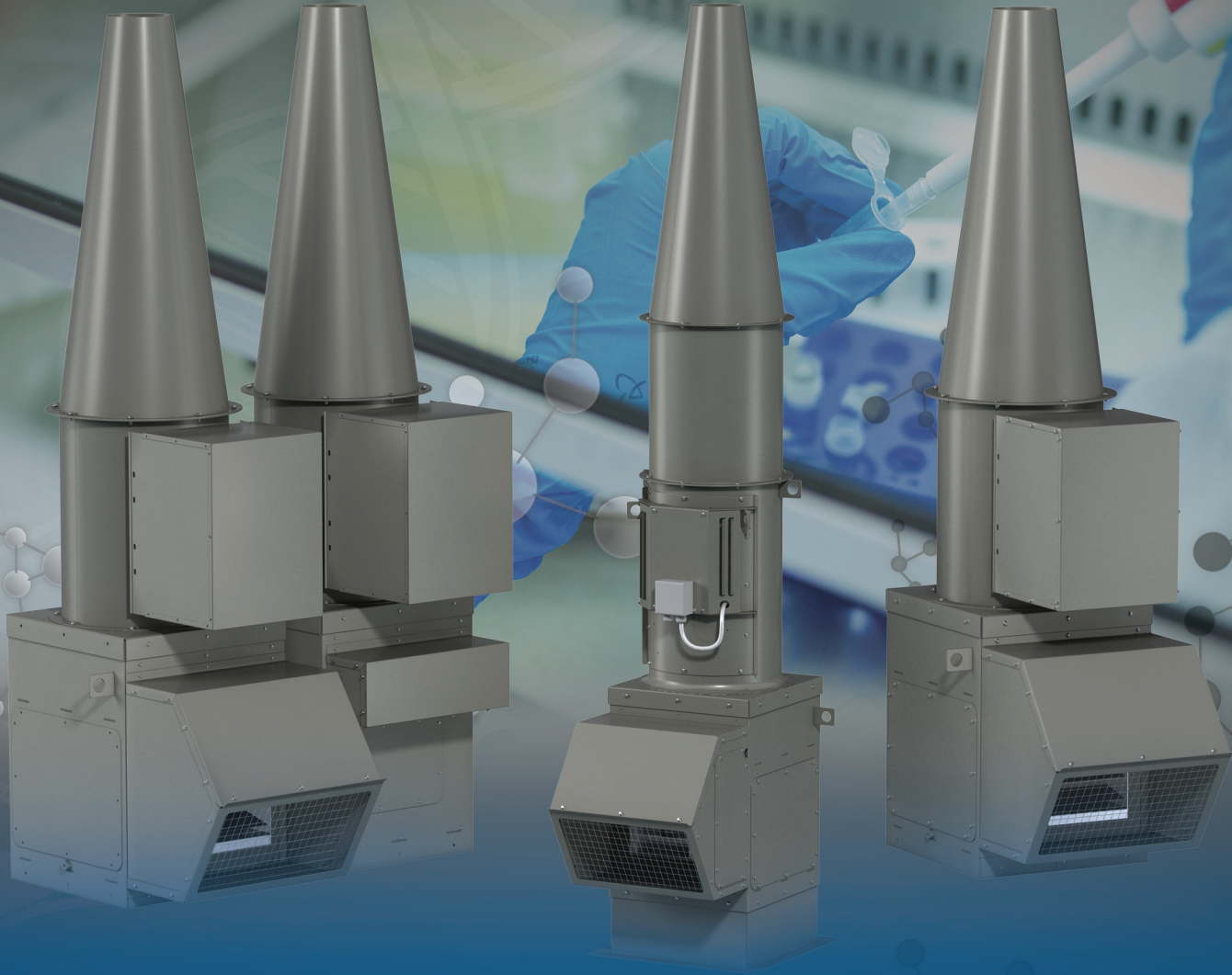



The Vektor®-H is a cost-effective, self-contained, high plume laboratory exhaust system designed to remove hazardous or noxious fumes from a laboratory, dilute the fumes with bypass air and expel them from the laboratory building, so the fumes do not contaminate the roof area or are re-entrained into building make-up air systems.

## Benefits of the Vektor-H:

- 

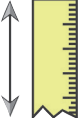
Applicable to constant or variable volume exhaust systems
- 

High plume discharge to prevent re-entrainment of contaminated exhaust effluent
- 

Meets ANSI Z9.5, NFPA 45 and ASHRAE height and design guidelines
- 

Configurable in single, double or triple fan systems providing options for increased capacity and system redundancy
- 

Spark B resistant construction
- 

Designed to withstand up to 125 mph wind loads without guy wires

Licensed to bear the AMCA Seal for FEI, Air & Sound Performance



Certified data may be found in Greenheck's Computer Aided Product Selection program (CAPS®).  
FEI - Fan Energy Index

## The Greenheck Vektor Advantage

The Greenheck Vektor-H laboratory exhaust system is a better, lower-cost alternative to a field built-up exhaust system.

- Installed quickly and easily on Greenheck's reinforced roof curb model GPFHL
- Requires less roof deck space
- A cleaner installation with fewer roof penetrations
- No performance losses due to field fabricated inlet or outlet ducts

## Applications

- High School and College Laboratories
- Compounding Pharmacies
- Hospital Isolation Rooms
- Forensic Labs
- Restaurant Exhaust

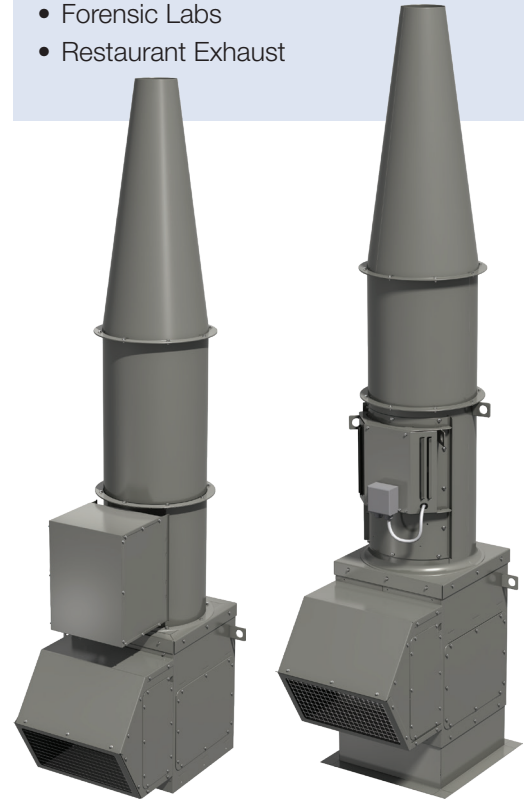

Belt drive

Direct drive

Direct drive over 20% more efficient than belt drive for lower operating costs.



Vektor-H system



Field built-up system

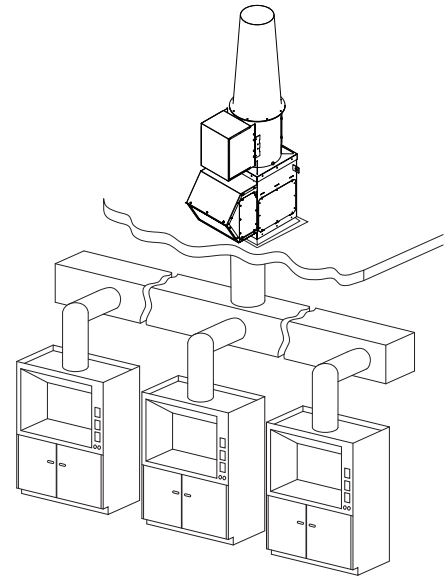
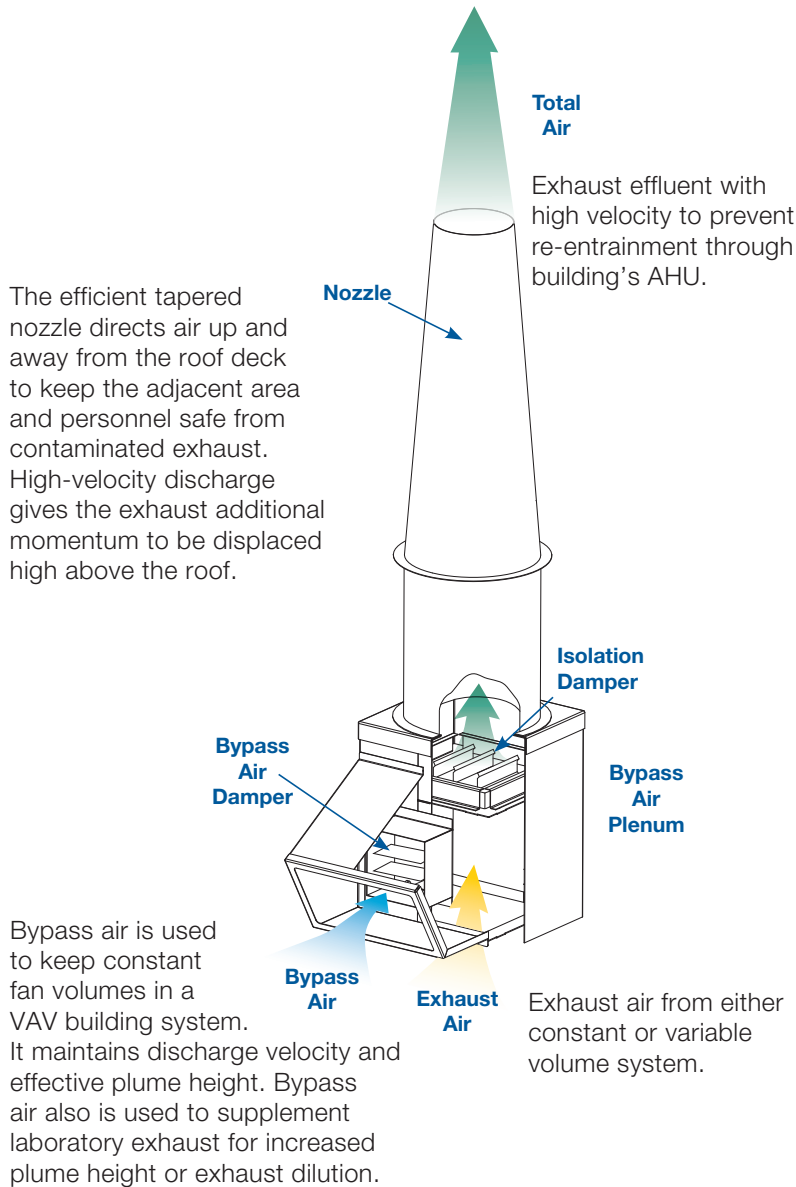

## Design Versatility

The Greenheck Vektor-H laboratory exhaust system can be applied to single as well as multiple manifolded fume hoods.

## System Controls

Factory programmed to adjust fan speed and dampers to maintain duct static pressure point. Stand-alone controls or connect to BMS.

(Refer to the Vektor System Controls catalog)



## Chemical Emission and Odor Dispersion – Plume Height Calculations

The effective plume height is an important factor in designing exhaust systems servicing laboratories. The effective plume height needs to be high enough to avoid exhaust re-entrainment into the same or adjacent buildings. Fan discharge type, concentration levels and airflow volumes all affect the needed effective plume height. The effective plume height ( $h_e$ ) is the physical height of the fan system ( $h_s$ ) plus the plume rise ( $h_r$ ).

ASHRAE 2019 Applications Handbook (Chapter 46) on laboratory design and the Greenheck CAPS<sup>®</sup> program use a geometric formula called momentum flux equation to calculate plume rise ( $h_r$ ). The formula takes into account downwind distance, the height of the building, prevailing wind speed and the terrain factor surrounding the building.

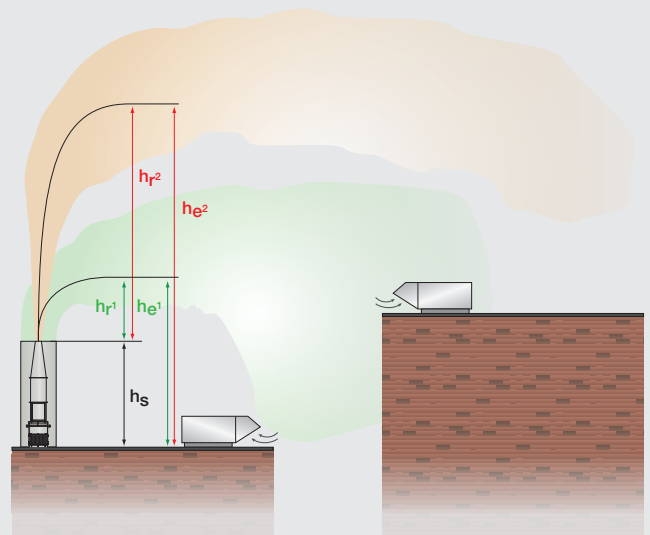

	Belt Drive	Direct Drive	
<b>Performance</b>	Volume range	500 - 26,000 cfm per fan	300 - 7,500 cfm per fan
	Static pressure	Up to 4 in. wg	Up to 4.5 in. wg
		Flexible performance modifications	No maintenance with sealed for life motor bearings
		Extended fan bearings lubrication lines	Motor labeled for use with VFD and shaft grounding as standard Over 20% more efficient than belt drive
<b>Standard</b>	High plume nozzle	✓	✓
	Maintains safe discharge velocity per design	✓	✓
	125 mph wind loading – No guy wires	✓	✓
	Spark B construction	✓	✓
	Sealed motor bearings – No maintenance		✓
	2.0 drive service factor – Minimum of 2 belts	✓	
	UL/cUL Listed for Power Ventilators (electrical)	✓	✓
	Multi-fan system – Up to 3 fans	✓	✓
LabCoat™ protective coating	✓	✓	
<b>Optional</b>	High wind certification – NOA certification #24-0123.02	✓	✓
	Seismic certification – HCAI OSP-0748		✓
	UL/cUL Listed for Power Ventilators for Restaurant Exhaust Applications	✓	
	Sure-Aire™ airflow monitoring system	✓	✓
	Laboratory exhaust system controls	✓	✓

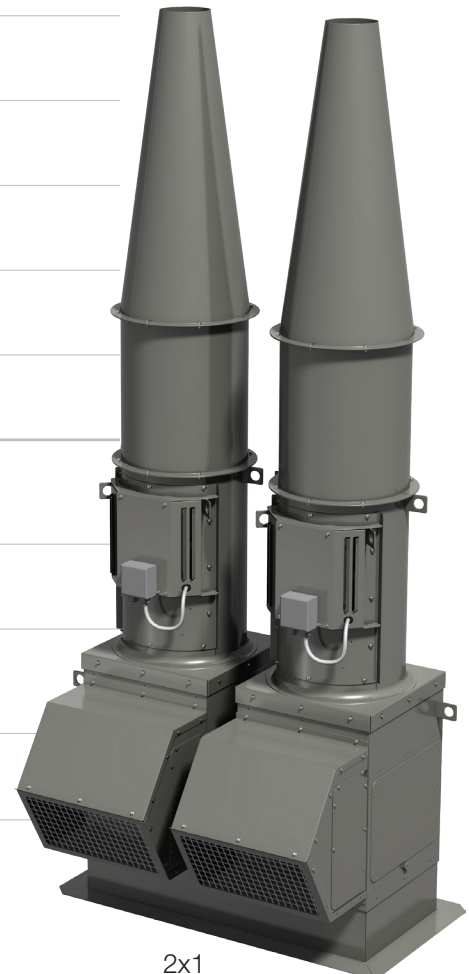

2x1  
Direct drive

## Licenses and Certifications

**AMCA** – For Vektor-H performance pages showing AMCA licensed data for Sound and Air Performance, please refer to the Vektor-H Laboratory Exhaust System Performance catalog.

**UL 705 Power Ventilator** – Vektor-H models are available with the UL/cUL 705 (Underwriters Laboratory) Listing on a wide variety of 50 and 60-hertz motors. This listing ensures the use of UL approved electrical components. Motors are available in NEMA totally enclosed, fan cooled (TEFC), or explosion-proof (EXP) designs.

**UL Restaurant and Grease Exhaust** – The Vektor-H, inline grease exhaust fan, is an alternative for kitchen applications when the requirement for a high plume rise is deemed necessary. The Vektor-H with grease option is designed to withstand the demands of high-temperature kitchen grease exhaust. UL is concerned with fans designed for the removal of smoke and grease-laden vapors.

**High Wind** – The Vektor-H has also been tested and certified by an independent third party to meet the hurricane and high wind standards of the Miami-Dade Building Code Compliance Office, the Florida Building Council, and the Texas Department of Insurance (TDI).

Complete certification reports can be found on the Miami-Dade website for the Notice of Acceptance (NOA) number 24-0123.02 ([www.miamidade.gov](http://www.miamidade.gov)), the Florida Building Code website for the Florida Product Approval number FL17237 ([www.floridabuilding.org](http://www.floridabuilding.org)), and the Texas Department of Insurance website under TDI number RV-88 ([www.tdi.texas.gov](http://www.tdi.texas.gov)).

**Seismic** – As an industry leader, Greenheck manufactures seismically-certified products to maintain structural integrity during and after a seismic event. Based on Greenheck's design and construction features, the Vektor-H direct drive system is seismic compliant for use in contaminated exhaust air applications. The Vektor-H is certified for HCAI's Special Seismic Certification Pre-approval under OSP-0748.

## LabCoat™ Corrosion-Resistant Coating

Components are electrostatically powder-coated with LabCoat, a two-part corrosion-resistant polyester coating. The standard color is RAL 7023 Concrete Grey. Optional colors are available upon request.

- **Step 1:** Advanced multistage surface preparation.
- **Step 2:** Basecoat of industrial epoxy, as a primer, is applied.
- **Step 3:** The finish coat of polyester resin (Hi-Pro Polyester), a super durable class of coating.

LabCoat is not affected by the UV component of sunlight (does not chalk), and has superior corrosion resistance to acids, alkalis, solvents and harsh environments (high humidity, coastal applications). The LabCoat system exceeds 4000 hour ASTM B117 Salt Spray Resistance.



Model Vektor-H is available with the UL/cUL 705 Electrical Listing File #E40001

### LabCoat Cross Section

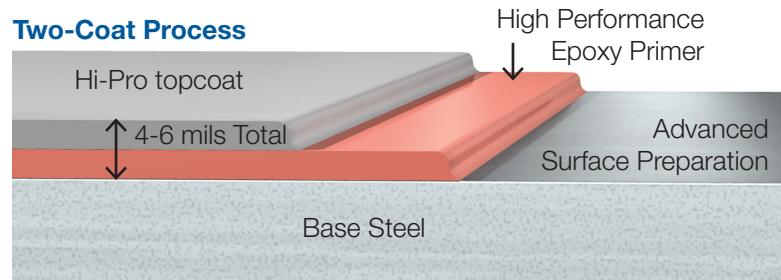

# Standard Construction Features and Options

- 1 Nozzle** - High velocity, conical discharge nozzle reduces system effects associated with a quick or abrupt reduction in the discharge stack diameter.
- 2 Extension** - Standard component on sizes 9 through 22 to increase the overall system height to a minimum of 10 ft (**3 m**) above the roof deck. The extension is manufactured from welded steel and coated with LabCoat.
- 3 Motor Cover (belt)** - Designed to protect the motor and drive components from rain, moisture, dust, and dirt. The motor cover is manufactured from welded steel and coated with LabCoat.
- 4 Cooling Vents (direct)** - Integrated venting to cool motor giving longer life and performance. Channels are sealed from the contaminated airstream.
- 5 NEMA-3R Toggle Disconnect Switch** - Factory-mounted and wired NEMA-3R switch is available to disconnect power before performing field service work.
- 6 Drives (belt)** - Belts and sheaves are sized for 200% of motor horsepower with a minimum of two belts.
- 7 Motor** - Premium efficient, standard NEMA frame, TEFC motor with 1.0 service factor when used with a variable frequency drive (VFD) and 1.15 service factor with across-the-line operation. **Direct drive** motors have sealed bearings, are VFD rated, and have integral shaft grounding.
- 8 Wheel** - A backward-inclined, non-overloading wheel manufactured of aluminum and coated with Hi-Pro, a specially formulated super durable class of coating.
- 9 Bypass Air Plenum (optional)** - Facilitates the addition of ambient air to the exhaust airstream. The additional air increases the dilution of the exhaust air and also increases the discharge momentum resulting in greater displacement above the roof. On variable volume systems, the bypass air plenum and damper allow the reduction of lab exhaust volume by adding ambient air to the exhaust airstream. This allows the fan to run at a constant speed without the need for a variable frequency drive. Bypass air plenums are constructed of heavy-gauge welded steel and are coated with LabCoat.
- 10 Isolation Damper (optional)** - A parallel blade damper is used to allow maintenance on a fan while others are in operation. The isolation damper also prevents backflow on a redundant fan while the system is operating. Gravity dampers are fabricated from a mill finish aluminum and control dampers from a mill finish 316 stainless steel. Control options are gravity or electric (2-position, spring return) actuators.
- 11 Bypass Air Damper (optional)** - Opposed blade damper used to bring ambient air into the fan system for additional dilution or an increase in plume rise. Dampers fabricated of a mill finish 316 stainless steel. Control options are electric or a manual quadrant.
- 12 Weatherhood** - (*included with Bypass Air Damper*) Designed to protect the bypass air damper and actuator (optional) from rain, moisture, dust, and dirt. Weatherhoods are manufactured from welded steel and coated with LabCoat.
- 13 Roof Curb** - A structural support fabricated of 14-gauge galvanized/galvaneal steel structurally reinforced to provide a minimum wind load rating of 125 mph (200 km/hr) without the use of guy wires on the installed Vektor-H system.

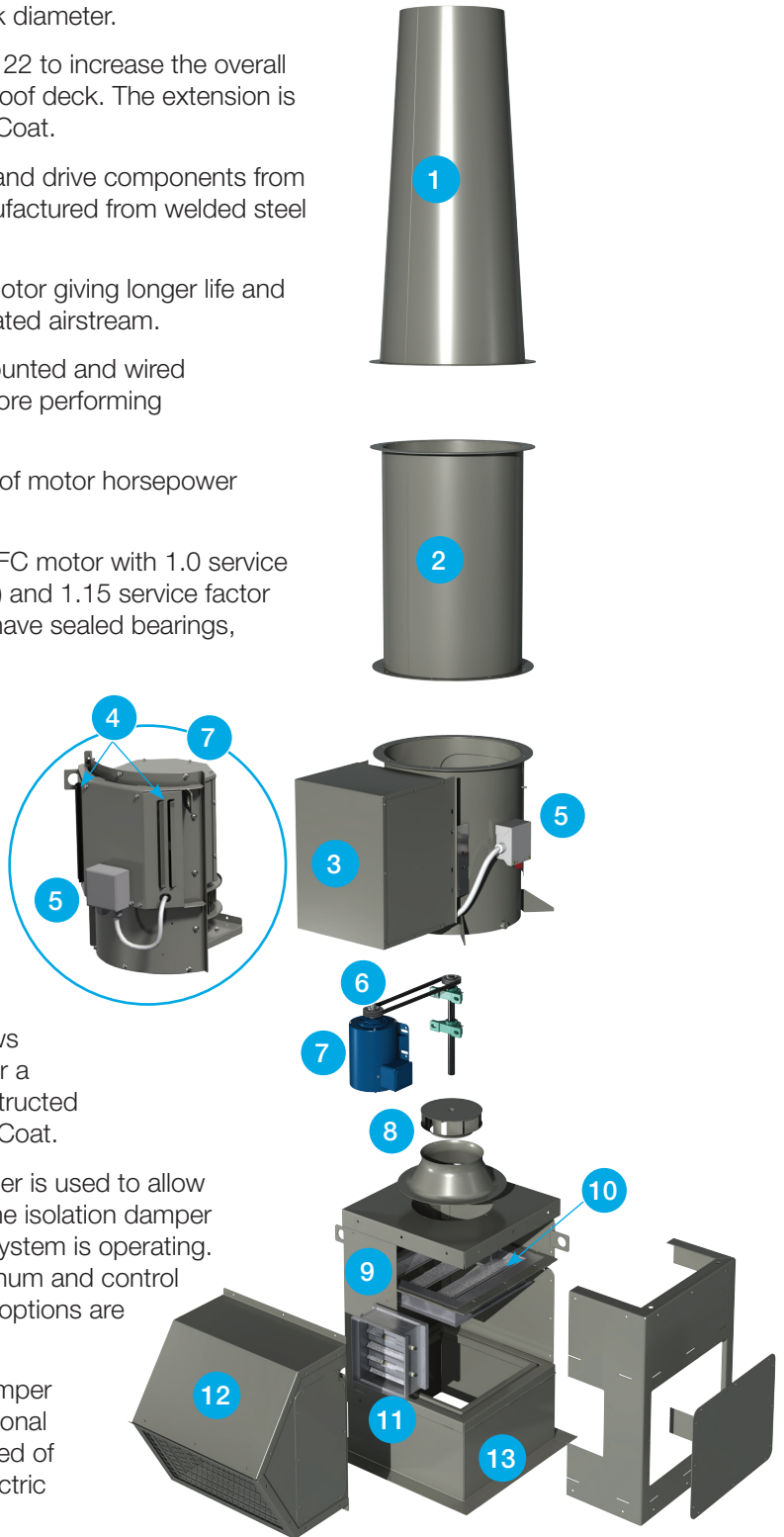

**Drain Connection** - A drain connection located at the bottom of the fan housing allows for the removal of any rain or condensation. An additional drain (standard) is located at the bottom of the bypass air plenum.

**Fasteners** - All fasteners in the airstream are stainless steel for additional corrosion-resistant protection.

**Spark-Resistant Construction** - All size fans are manufactured to meet AMCA type “B” spark-resistant construction (aluminum wheel and shaft seal).

**Bearings (belt)** - Air handling quality bearings in excess of L<sub>10</sub> - 100,000-hour bearing life (equal to L<sub>50</sub> - 500,000 hrs). Nylon extended lube lines allow for fan bearing lubrication.



## Ease of Maintenance

The Vektor-H **belt drive** provides safe, easy inspection and maintenance of internal fan components. By removing one access panel, service to the fan wheel, shaft and bearing assembly is accomplished without removing the fan from the system.

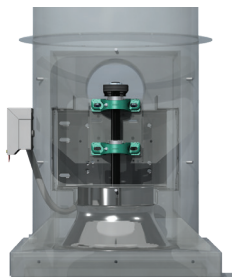

The **direct drive** inlet cone, wheel and motor are combined in a single assembly for easy removal. Inspection door provided to view and inspect wheel.

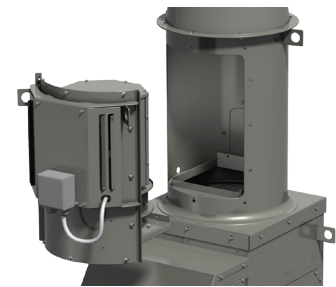

## Model Number Nomenclature

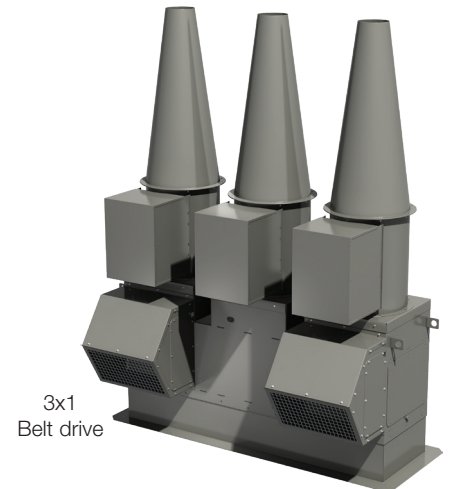
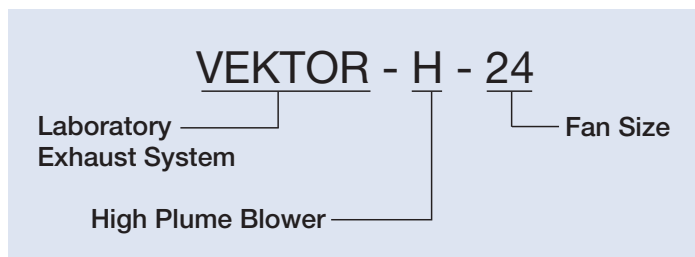

## Vektor Sure-Aire™

Continuously monitor critical laboratory fan exhaust and building exhaust flow without airflow probes in the exhaust airstream. Benefits of the Sure-Aire™ system:

- Continuously measures critical fan and laboratory exhaust flow
- Reports values to building management system (BMS)
- No system effect or resistance to airflow
- No additional pressure loss
- No increase in fan RPM, sound or brake horsepower
- No additional energy cost for the building owner
- No probe corrosion to cause fan failure

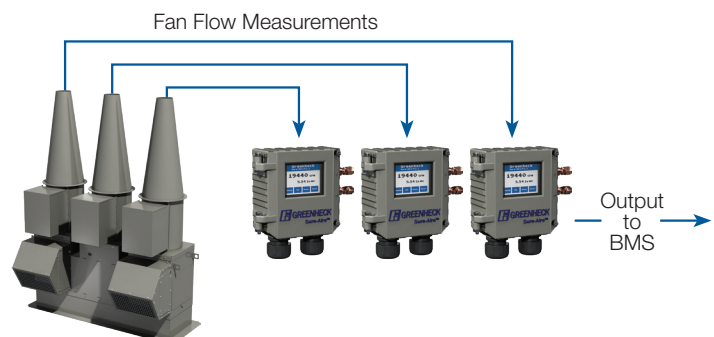



# Family of Lab Exhaust Systems

**High Plume** - Effective means of creating a discharge plume height to prevent re-entrainment of chemical exhaust fumes into make-up air systems.



### Vektor-H

- High plume discharge nozzle
- Centrifugal wheel
- Compact design / sealed airstream components
- Up to 26,000 cfm and 4 in. wg



### Vektor-MH

- High plume nozzle
- Mixed flow wheel / bifurcated housing
- Compact design
- Up to 47,000 cfm and 11 in. wg

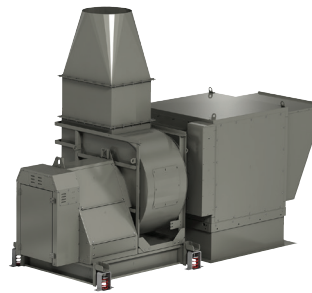

### Vektor-CH

- High plume nozzle
- Centrifugal wheel
- Up to 56,000 cfm and 12 in. wg

**High Plume Dilution** - Fan design that entrains and mixes outside ambient air into the exhaust airstream prior to exiting out the windband discharge. Potentially hazardous exhaust or exhaust fumes are diluted and dispersed quickly.

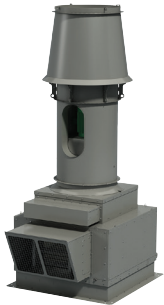

### Vektor-MD

- High plume discharge nozzle with entrainment and dilution
- Mixed flow wheel / bifurcated housing
- Compact design
- Up to 83,000 cfm and 11.5 in. wg

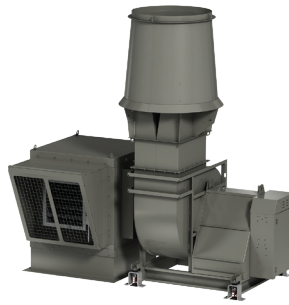

### Vektor-CD

- High plume discharge nozzle with entrainment and dilution
- Centrifugal wheel
- Highest efficiency / easy service design
- Up to 122,000 cfm and 13.5 in. wg

**High Plume Variable Geometry Nozzle (VGN)** - The discharge area automatically adjusts to maintain a constant discharge velocity and remain compliant to design codes. VGN maximizes effective plume heights during periods of reduced flow and lower discharge velocity fixed nozzles.



### Vektor-MS

- VGN discharge nozzle technology
- Variable volume flow – constant velocity discharge
- Mixed flow wheel / bifurcated housing
- Up to 32,000 cfm and 10 in. wg

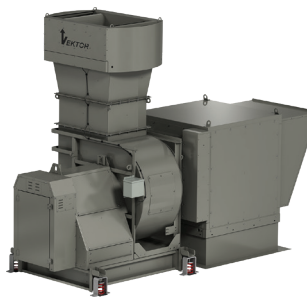

### Vektor-CS

- VGN discharge nozzle technology
- Variable volume flow – constant velocity discharge
- Centrifugal wheel
- Up to 32,000 cfm and 10 in. wg

## Our Commitment

*As a result of our commitment to continuous improvement, Greenheck reserves the right to change specifications without notice.*

Product warranties can be found online at [Greenheck.com](http://Greenheck.com), either on the specific product page or in the literature section of the website at [Greenheck.com/Resources/Library/Literature](http://Greenheck.com/Resources/Library/Literature).

