

HURRICANE LOUVER: ALUMINUM 6" DEEP, FIXED DRAINABLE TYPE BLADE, WITHSTANDS DESIGN PRESSURE UP TO +/- 180 PSF

MODEL LE-32 STANDARD SPECIFICATIONS

- FRAME: 6" DEEP CHANNEL, .125" THICK 6063-T6 EXTRUDED ALUMINUM ALLOY.
- BLADES: .081" THICK 6063-T5 EXTRUDED ALUMINUM ALLOY.
.125" OPTIONAL.
- FINISH: MILL.
- SCREEN: 1/2" REMOVABLE EXPANDED ALUMINUM BIRD SCREEN, LOCATED ON INTERIOR.
- MAXIMUM PANEL SIZE: 96" x 96".
WINDLOAD REQUIREMENTS MAY LIMIT PANEL SIZES.
- MINIMUM PANEL SIZE: 12" x 12".
- DIMENSIONS: "A" (WIDTH) AND "B" (HEIGHT) ARE OPENING SIZES.
LOUVERS ARE MADE 1/2" UNDERSIZE.
- DESIGN DATA: PASSED MIAMI-DADE COUNTY FLORIDA TEST PROTOCOLS
TAS (PA) 100(A) (*DAMPER REQUIRED - REFER TO NOA)
TAS (PA) 201, TAS (PA) 202, AND TAS (PA) 203.
- * PANELS OVER 60" WIDE WILL HAVE A 2 X 2 X 1/4 VERTICAL INTERIOR
BLADE SUPPORT ANGLE AT APPROXIMATE CENTER OF PANELS.
- MIAMI-DADE COUNTY NOA# 23-0713.09
- FLORIDA PRODUCT APPROVAL FL# 7453.1
- AMCA 540 LISTED (IMPACT RESISTANT LOUVER - BASIC PROTECTION LEVEL D)
- AMCA 550 LISTED (HIGH VELOCITY RAIN RESISTANT WITH BLADES FULLY OPEN AND OPTIONAL
VERTICAL BLADE LOUVER MODULE ATTACHED TO THE INTERIOR SIDE).

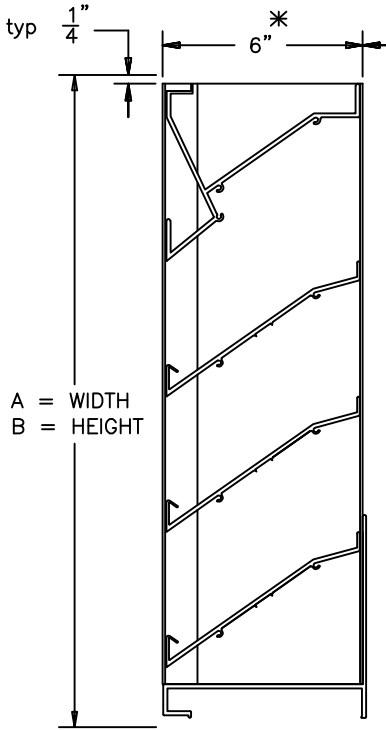

SECTION VIEW

A = WIDTH
B = HEIGHT

American Warming and Ventilating certifies that the model LE-32 louver shown herein is licensed to bear the AMCA Seal. The ratings shown are based on tests and procedures performed in accordance with AMCA Publication 511 and comply with the requirements of the AMCA Certified Ratings Program. The AMCA Certified Ratings Seal applies to air performance ratings and water penetration ratings.



AWV certifies that the model LE-32 shown herein is approved to bear the AMCA Listing Label. The ratings shown are based on tests and procedures performed in accordance with AMCA Publications and comply with the requirements of the AMCA Listing Label Program. The AMCA Listing Labels apply to Wind Borne Debris Impact Resistant Louvers and High Velocity Wind Driven Rain Resistant Louvers (with the optional LE-29 attached).

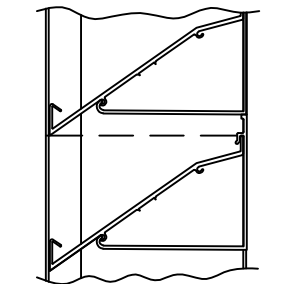

STANDARD HORIZONTAL MULLION

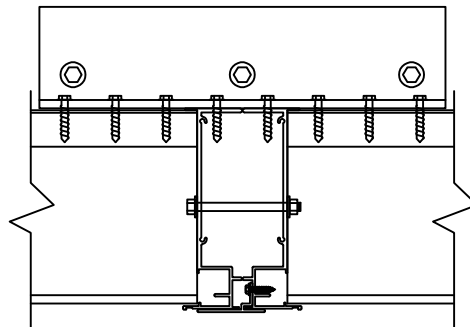

STANDARD VERTICAL MULLION

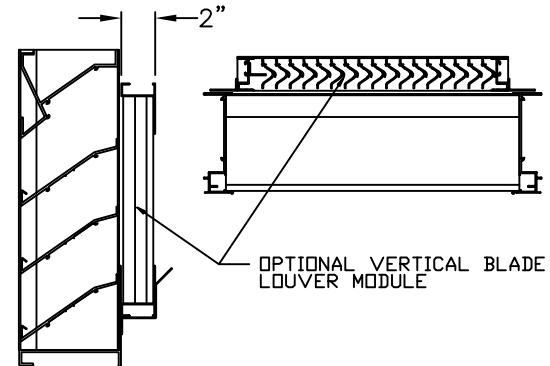

OPTIONAL VERTICAL BLADE LOUVER MODULE

REFER TO SUPPLEMENTAL DATA SHEET FOR MORE INFORMATION.

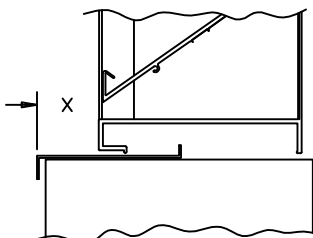

EXTENDED SILL OPTIONAL

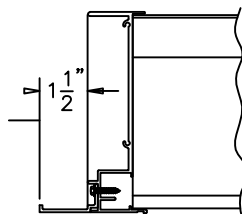

OPTIONAL FLANGED FRAME (JAMB SHOWN)

awv american warming and ventilating

A MESTEK COMPANY

7301 INTERNATIONAL DRIVE HOLLAND, OHIO
Phone (419) 865-5000 Fax (419) 865-1375

LE-32 STATIONARY LOUVER

DRN. BY	JMC	DWG. NO.	REV.
DATE	09/09/24	LE-32	

Water Penetration : 0.01 oz (3.0 g) at 1250 fpm (6.35 m/s) recommended free area velocity
Pressure Drop : 0.21 in wg (52 Pa.) at 1250 fpm (6.35 m/s) and 11550 scfm (5.45 scm/s)
Free Area : 9.24 sq ft (0.858 sq m) = 57.8% for 48" x 48" (1.22m x 1.22m) test size

INTAKE PRESSURE DROP

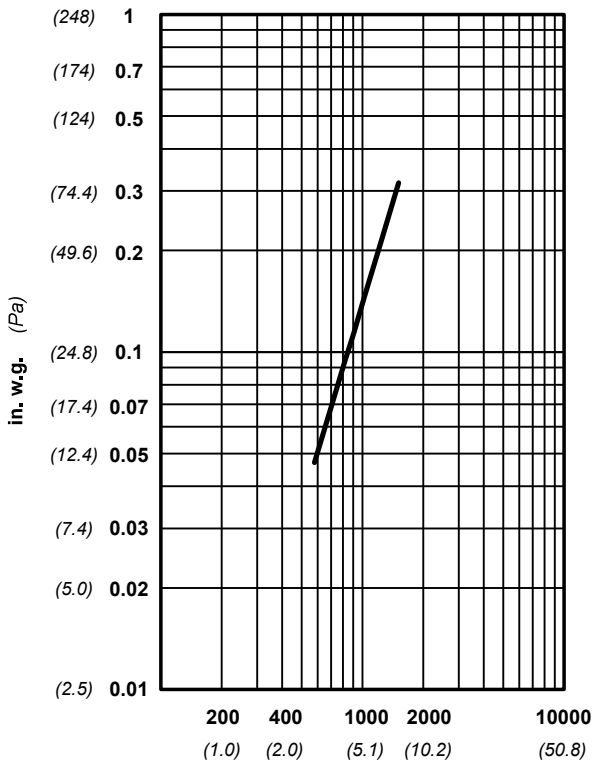

VELOCITY THROUGH FREE AREA fpm (m/s)

Airflow at standard air density - .075 lbs per cu ft
 Ratings do not include the effect of a wire bird screen
 Test based on a 48" x 48" test size per AMCA Standard 511
 AMCA Figure 5.5 Test Setup

FREE AREA IN SQUARE FEET (sq meters)

		WIDTH								
		in. mm	12 305	24 610	36 914	48 1219	60 1524	72 1829	84 2134	96 2438
HEIGHT	12 305	0.18	0.43	0.69	0.94	1.16	1.42	1.67	1.93	
	24 610	0.064	0.158	0.251	0.345	0.426	0.519	0.613	0.706	
	36 914	0.112	0.275	0.439	0.601	0.744	0.907	1.070	1.233	
	48 1219	0.160	0.393	0.625	0.858	1.062	1.295	1.527	1.760	
	60 1524	0.208	0.510	0.813	1.115	1.380	1.682	1.984	2.287	
	72 1829	0.255	0.628	1.000	1.372	1.697	2.070	2.441	2.814	
	84 2134	0.304	0.745	1.187	1.629	2.015	2.457	2.899	3.341	
	96 2438	0.351	0.863	1.374	1.886	2.334	2.845	3.357	3.868	

WATER PENETRATION

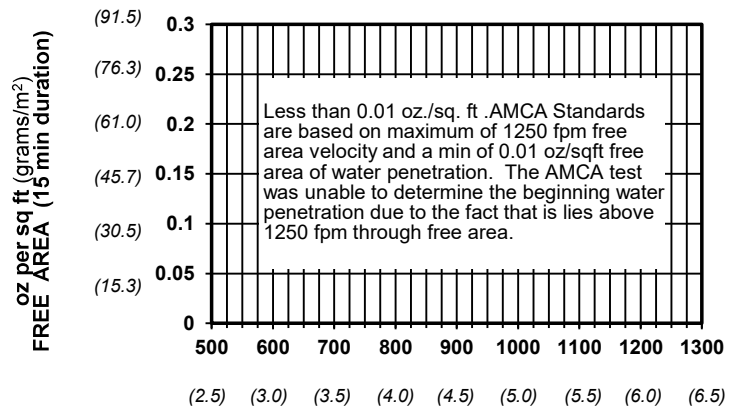

VELOCITY THROUGH FREE AREA fpm (m/s)

Both maximum recommended free area velocity and beginning of water penetration are 1250 fpm at standard air - .075 lbs per cu ft.
 The above water penetration data is based on mill finish, 48" x 48" test size per AMCA Standard 511.



American Warming and Ventilating certifies that the model LE-32 louver shown herein is licensed to bear the AMCA Seal. The ratings shown are based on tests and procedures performed in accordance with AMCA Publication 511 and comply with the requirements of the AMCA Certified Ratings Program. The AMCA Certified Ratings Seal applies to air performance ratings and water penetration ratings.

LE-32

Below is an explanation of how to use the AMCA Performance data for the recommended free area velocity of 1250 fpm (6.35 m/s).

To determine minimum free area required for louver:

- Step #1:** Divide the required CFM flow by the maximum recommended free area velocity.
- Step #2:** Select the most desirable louver size, from the free area table, that meets the minimum free area requirement.
- Step #3:** Compare specified performance to the certified water penetration and pressure drop ratings.

Openings that require multiple louver panels in both width and height will require internal structural supports. It is recommended that large openings be divided with structural members so that the louvers will span either width or height with a single panel. Unusually high wind loading may require structural supports on non-multiple wide and multiple high assemblies. **Structural supports and mounting accessories are not supplied as a standard.**

Example: Given: 15000 CFM design flow

Step #1:

$$\text{min. free area} = \frac{\text{Design CFM}}{\text{Max. Recommended Velocity}}$$

$$= \frac{15000}{1250} = 12 \text{ sq ft}$$

Step #2: From the free area table above the approximate louver size is 48" x 60" = (12 sq ft)

STANDARD BOXED FRAME LE-32 INSTALLATION INSTRUCTIONS

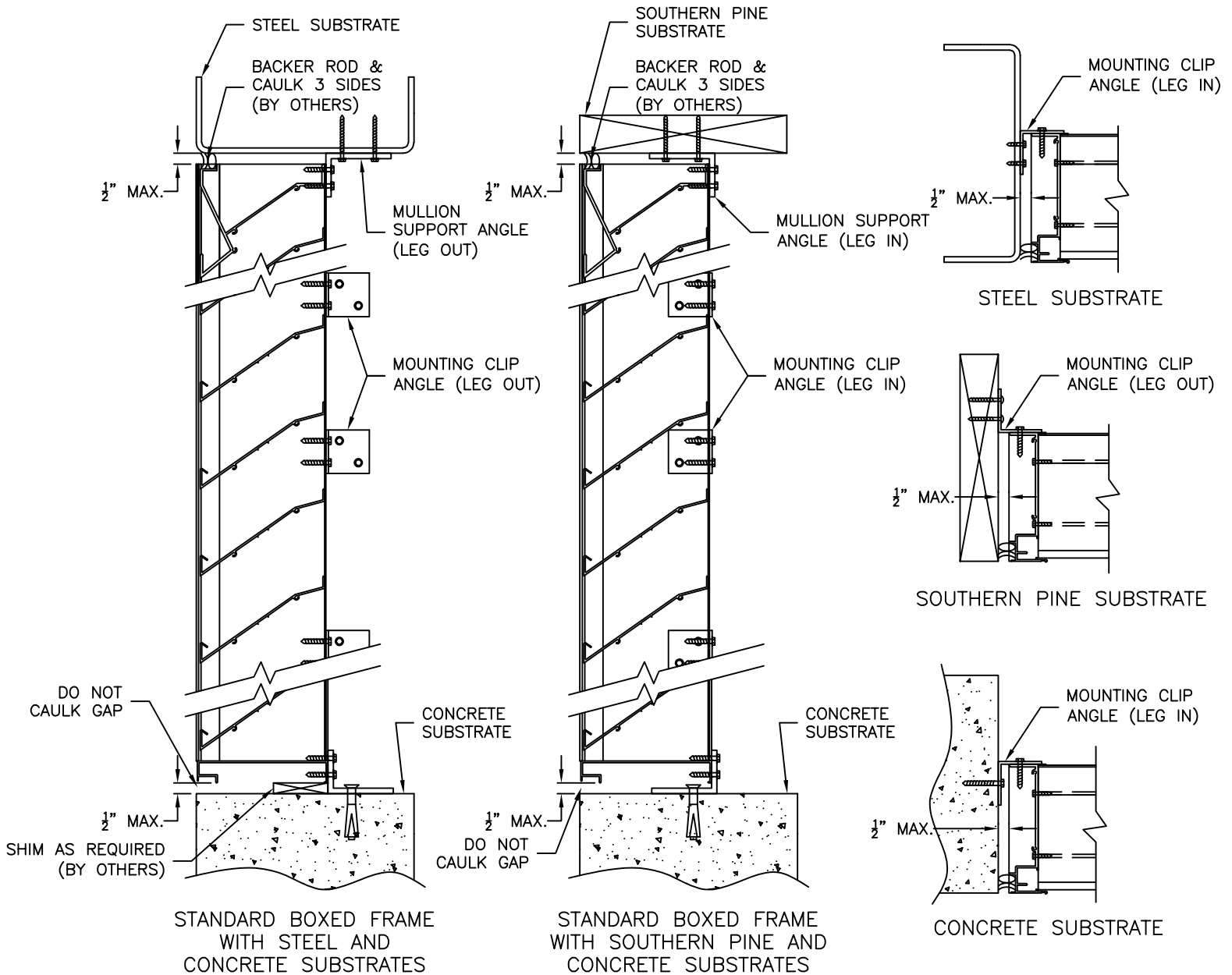

NOTES:

- 1) MOUNTING CLIP ANGLES AND MULLION SUPPORT ANGLES CAN BE INSTALLED WITH "LEGS IN" OR "LEGS OUT" FOR ANY APPROVED SUBSTRATE.
- 2) "LEGS OUT" IS THE STANDARD CONSTRUCTION, "LEGS IN" IS OPTIONAL.
- 3) USE SHIMS TO OBTAIN UNIFORM CLEARANCE BETWEEN THE LOUVER AND THE LOUVER OPENING ON ALL SIDES, SHIMS ARE BY OTHERS.
- 4) SHIMS UNDER SILL PANS MUST ALLOW ENOUGH SPACE TO INSERT "LEG IN" OPTION INTO THE OPENING.
- 5) SEE DADE COUNTY NOA 23-0713.09 FOR INSTALLATION DETAILS.

FLANGED SLEEVE LE-32 INSTALLATION INSTRUCTIONS

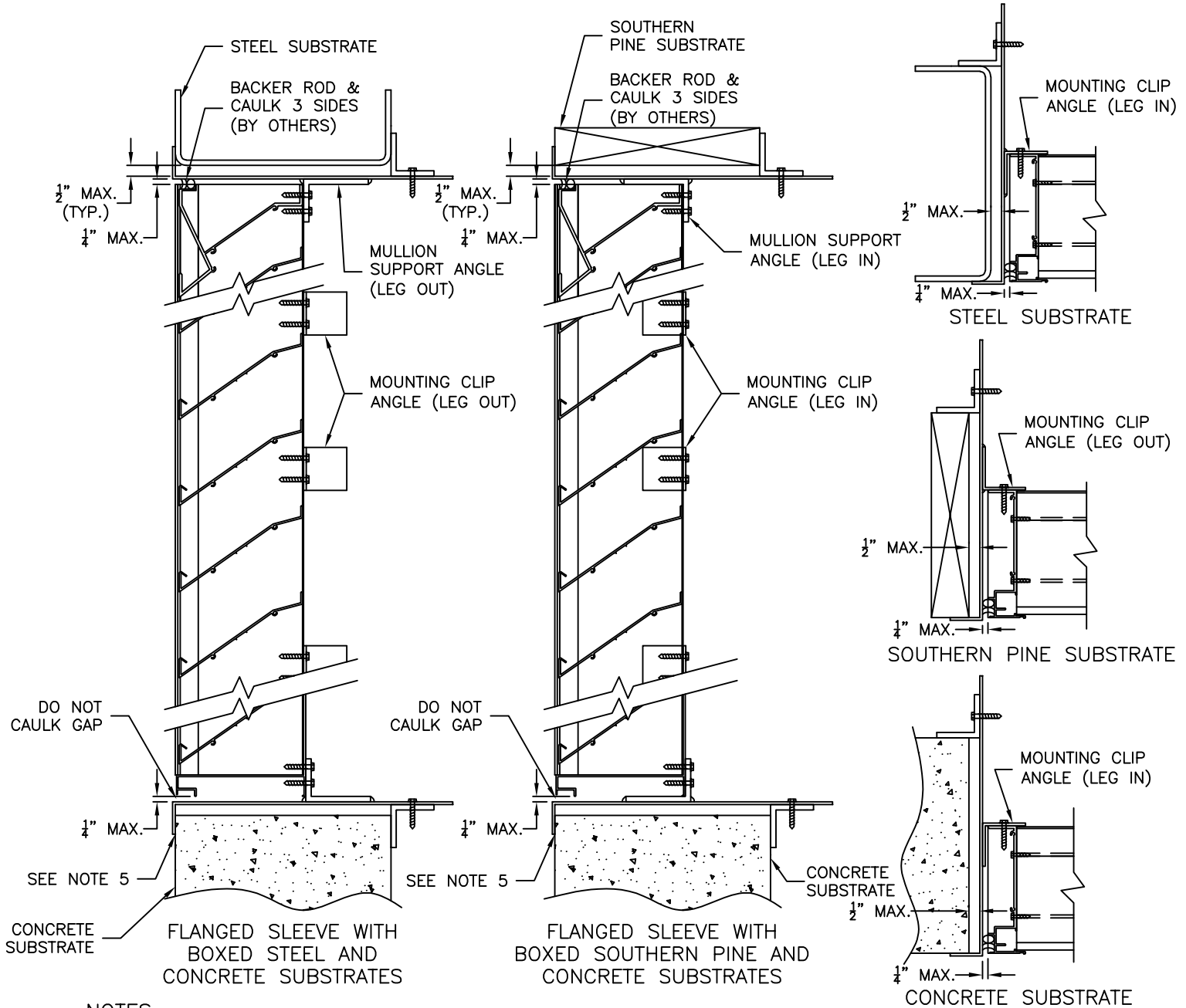

NOTES:

- 1) MOUNTING CLIP ANGLES AND MULLION SUPPORT ANGLES CAN BE INSTALLED WITH "LEGS IN" OR "LEGS OUT" FOR ANY APPROVED SUBSTRATE.
- 2) "LEGS OUT" IS THE STANDARD CONSTRUCTION, "LEGS IN" IS OPTIONAL.
- 3) THE FLANGED SLEEVE OPTION CAN BE USED WITH ANY APPROVED SUBSTRATE.
- 4) USE SHIMS TO OBTAIN UNIFORM CLEARANCE BETWEEN THE LOUVER AND THE LOUVER OPENING ON ALL SIDES, SHIMS ARE BY OTHERS.
- 5) SEALANT/CAULK BETWEEN FLANGED ANGLE SLEEVE AND SUBSTRATE (TYP. 4 SIDES) BY INSTALLER.
- 6) TWO MOUNTING ANGLES RUN THE FULL HEIGHT OF LOUVER.
- 7) SEE DADE COUNTY NOA 23-0713.09 FOR INSTALLATION DETAILS.

FLANGED SLEEVE INSTALLATION INSTRUCTIONS FOR TAS-100 APPROVED LE-32 LOUVER / DAMPER

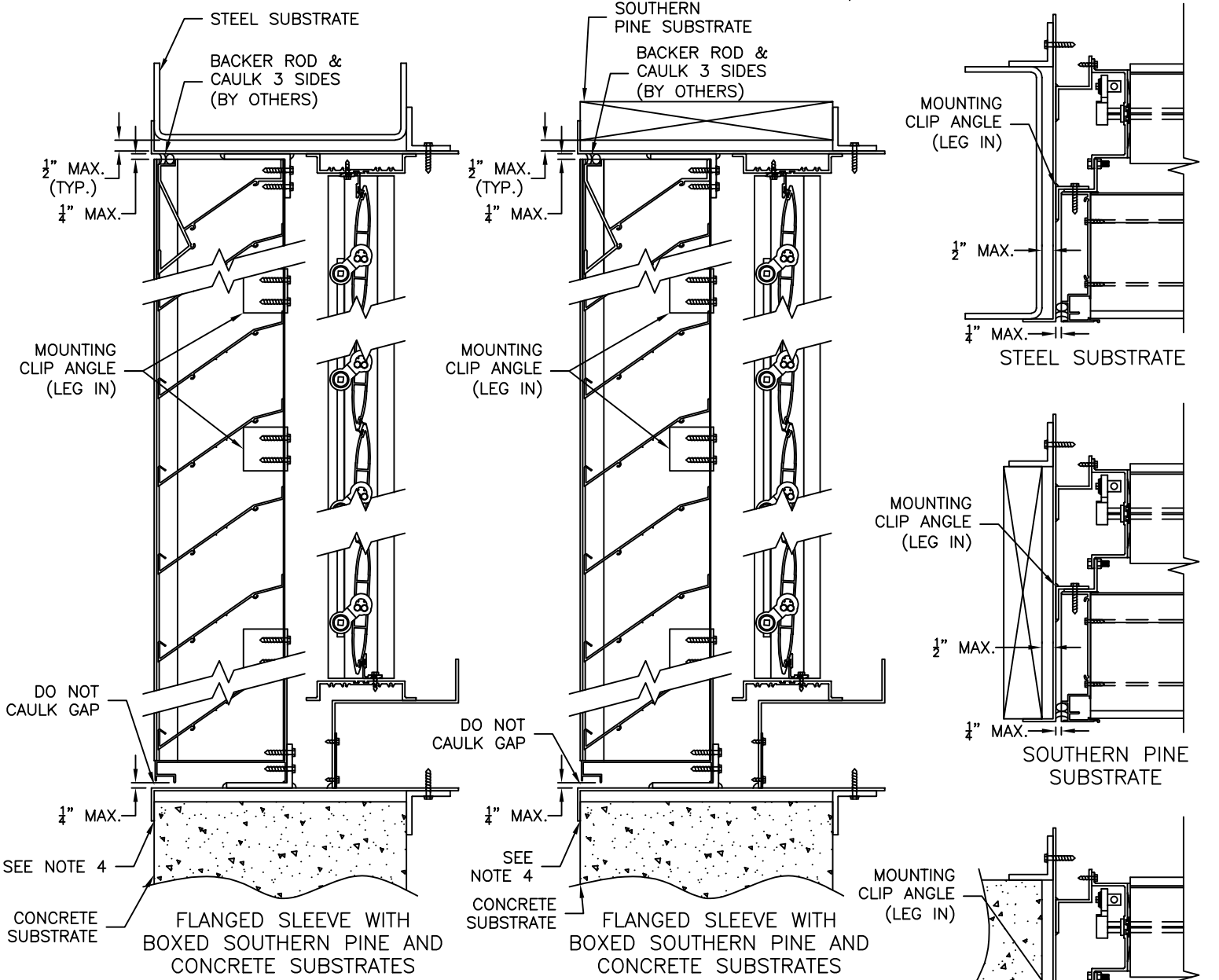

NOTES:

- 1) MOUNTING CLIP ANGLES AND MULLION SUPPORT ANGLES ARE TO BE INSTALLED WITH "LEGS IN" FOR ANY APPROVED SUBSTRATE.
- 2) THE FLANGED SLEEVE (14" DEEP) OPTION CAN BE USED WITH ANY APPROVED SUBSTRATE.
- 3) USE SHIMS TO OBTAIN UNIFORM CLEARANCE BETWEEN THE LOUVER AND THE LOUVER OPENING ON ALL SIDES, SHIMS ARE BY OTHERS.
- 4) SEALANT/CAULK BETWEEN FLANGED ANGLE SLEEVE AND SUBSTRATE (TYP. 4 SIDES) BY INSTALLER.
- 5) TWO MOUNTING ANGLES RUN THE FULL HEIGHT OF LOUVER.
- 6) SEE DADE COUNTY NOA 23-0713.09 FOR INSTALLATION DETAILS.