

DVAC

DUCT VENTILATION AIR CONDITIONING Co. (W.L.L.)

Acoustic Louvers Catalogue

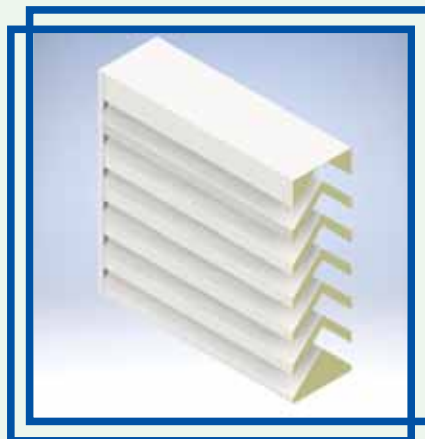

Type GIAL-300



DVAC Certifies that the **Acoustic Louver Model GIAL** shown herein is licensed to bear the **AMCA Seal**. The Ratings are based on tests and procedures performed in accordance with **AMCA Publication 511** and comply with the requirements of the **AMCA Certified Ratings Program**. The **AMCA Certified Rating Seal** applies to **Sound and Air Performance Ratings**.



- Introduction
- Description
- Standard Construction

INTRODUCTION

The Acoustic Louvers allow Air to flow through with minimal pressure drop and maximum sound attenuation. They are ideal for air intake and exhaust openings as well as ventilation openings in mechanical equipment rooms or acoustic enclosures.

DESCRIPTION

DVAC Acoustic Louvers are designed specifically for situations where large amounts of air must flow through a grid and where the space for installation is limited. These Louvers are an outside air grille combined with acoustic damping in one product; they offer insulated blades which provide effective sound attenuation and with appearance of weather protection louver. These louvers can be used in both construction and industrial projects.

External Acoustic Louvers:

DVAC provides a high quality of Louvers for external walls. Standard Color RAL 9010. Sound absorption and weather resistance structure with insulated blade inclined at an angle of 45° to protect against rain water penetration; a special design by DVAC, 32kg/m³ Density Fiberglass filled blades provide a best solution for sound absorption.

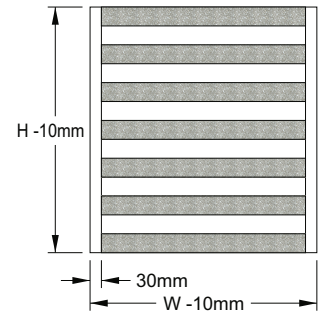
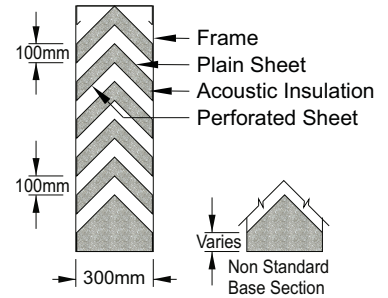

STANDARD CONSTRUCTION

DVAC Acoustic Louvers are composed of frame and horizontal blade assembly, fabricated with a high quality of Galvanized steel with the advantage of durability and anti-corrosion.

- **Casing:** Shall be made of Galvanized Steel 1.2mm Thick, complying with ASTMA653 and Having G90 Coating Designation.
- **Blades:** Shall be made of Galvanized Steel complying with ASTMA653 and having G90 Coating Designation, 1.0mm Thick exterior surface and 0.6mm perforated steel sheet with a Free Area of 22.5% interior that protects the insulation.
- **Free Area:** 26%.
- **Acoustic Materials:** Black, strong, durable, dimensionally stable woven glass fabric complying with the following Standards:
 - Surface Burning Characteristics: UL723, ASTM E84, BS 476.
 - Fire Resistance: NFPA90A&B, NFPA255.
 - Flame Spread Classification not more than 25.
 - Smoke Development Rating not more than 50.
 - 32 kg/m³ Density.

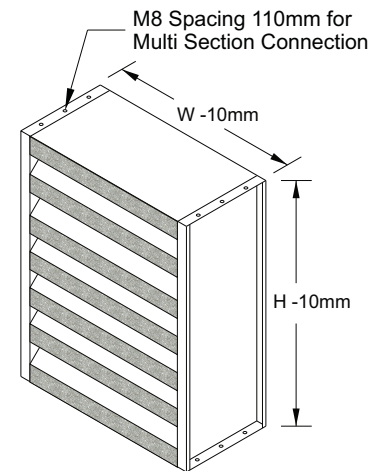

Optional:

Bird Screen: Shall be made of Hot Dip Galvanized 12x12x1.0mm

Size Limitations:

- **Minimum Height** : 24" (600mm)
- **Maximum Height** : *Single section: 72" (1800mm)
*Multiple sections: Unlimited
- **Minimum Width** : 12" (300mm)
- **Maximum Width** : *Single section: 72" (1800mm)
*Multiple sections: Unlimited



Ordering example:
GIAL-300 300x300
Material Code _____
Width x Height _____

* Materials Used for GIAL:

- **Galvanized Steel:** (Standard) L.F.Q. Complying with ASTM A653 & Having G90 Coating Designation.
- **Stainless Steel:** (Optional) Complying with ASTM A240M / A480M, Grade 304, 304L, 316 & 316L.
- **Aluminum Metal:** (Optional) Complying with ASTM B209, Alloy 3003, Temper H14.

ENGINEERING AND PERFORMANCE DATA

1- Acoustic Performance (As per Test 37446-S1)

Type GIAL-300	Frequency (Hz)	125	250	500	1k	2k	4k
	Transmission Loss (TL) dB	5	7	13	14	17	18
	Noise Reduction (NR)	11	13	19	20	23	24

2- Sound Transmission Coefficient (STC)

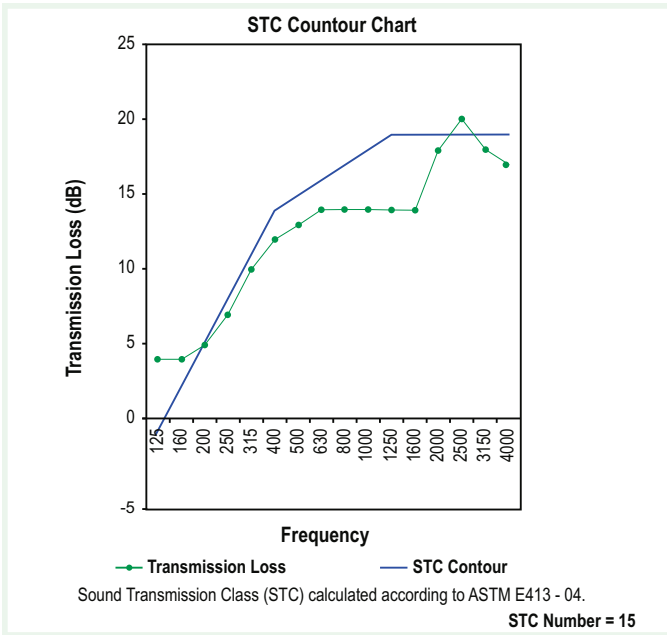

3- Air Performance Rating

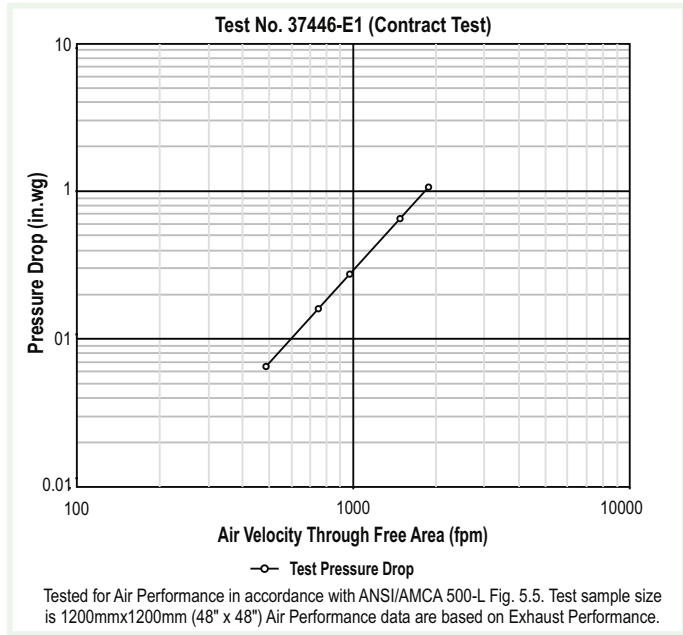

Free Area Chart (Sqm)

		Width																
		(mm)	300	400	500	600	700	800	900	1000	1100	1200	1300	1400	1500	1600	1700	1800
Height	600	0.03	0.05	0.06	0.08	0.09	0.10	0.12	0.13	0.15	0.16	0.17	0.19	0.20	0.22	0.23	0.24	
	700	0.05	0.07	0.09	0.11	0.13	0.16	0.18	0.20	0.22	0.24	0.26	0.28	0.30	0.32	0.34	0.37	
	800	0.05	0.07	0.09	0.11	0.13	0.16	0.18	0.20	0.22	0.24	0.26	0.28	0.30	0.32	0.34	0.37	
	900	0.07	0.10	0.12	0.15	0.18	0.21	0.24	0.26	0.29	0.32	0.35	0.38	0.40	0.43	0.46	0.49	
	1000	0.07	0.10	0.12	0.15	0.18	0.21	0.24	0.26	0.29	0.32	0.35	0.38	0.40	0.43	0.46	0.49	
	1100	0.08	0.12	0.15	0.19	0.22	0.26	0.29	0.33	0.36	0.40	0.43	0.47	0.50	0.54	0.57	0.61	
	1200	0.08	0.12	0.15	0.19	0.22	0.26	0.29	0.33	0.36	0.40	0.43	0.47	0.50	0.54	0.57	0.61	
	1300	0.10	0.14	0.18	0.23	0.27	0.31	0.35	0.39	0.44	0.48	0.52	0.56	0.60	0.65	0.69	0.73	
	1400	0.10	0.14	0.18	0.23	0.27	0.31	0.35	0.39	0.44	0.48	0.52	0.56	0.60	0.65	0.69	0.73	
	1500	0.12	0.17	0.22	0.26	0.31	0.36	0.41	0.46	0.51	0.56	0.61	0.66	0.71	0.75	0.80	0.85	
1600	0.12	0.17	0.22	0.26	0.31	0.36	0.41	0.46	0.51	0.56	0.61	0.66	0.71	0.75	0.80	0.85		
1700	0.13	0.19	0.25	0.30	0.36	0.41	0.47	0.53	0.58	0.64	0.69	0.75	0.81	0.86	0.92	0.97		
1800	0.13	0.19	0.25	0.30	0.36	0.41	0.47	0.53	0.58	0.64	0.69	0.75	0.81	0.86	0.92	0.97		

* Materials Used for GIAL:

- **Galvanized Steel:** (Standard) L.F.Q. Complying with ASTM A653 & Having G90 Coating Designation.
- **Stainless Steel:** (Optional) Complying with ASTM A240M / A480M, Grade 304, 304L, 316 & 316L.
- **Aluminum Metal:** (Optional) Complying with ASTM B209, Alloy 3003, Temper H14.



DUCT VENTILATION AIR CONDITIONING Co. (W.L.L.)

Small Industries Zone - Pink Area Zone 81 - Street 13 - Bldg. 57
Tel: +974 44 500 118 - 44 500 119 - 33 369 119 - Fax: +974 44 500 117 - PO. Box: 55619
Doha, State Of Qatar - Email: info@dvac-duct.com - Website: www.dvac-duct.com

DVAC Acoustic Louvers Catalogue Rev.01
Issued Date: January 2020