

Mixed Flow Fans

Models QEI, QEID

Quiet Efficient Tubular Inline

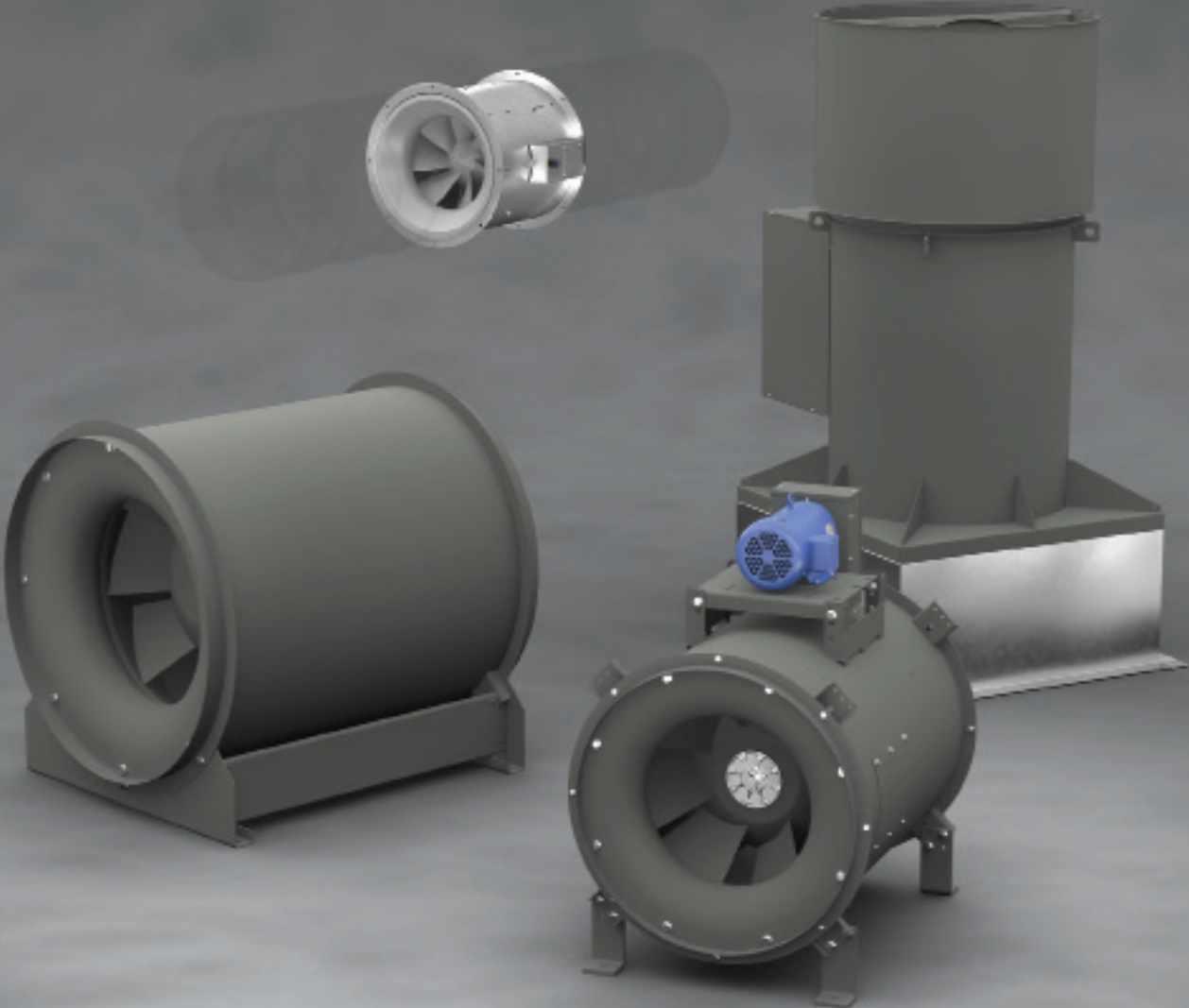

BUILDING VALUE IN AIR.



September
2024

Quiet & Efficient Inline

Mixed Flow Fans

Mixed flow inline fans can be used for a wide variety of commercial, institutional, and industrial applications, handling everything from clean, grease-laden or high-temperature air for supply, exhaust, or return air. Greenheck's unique wheel design excels in applications where low sound is critical. In addition, Greenheck's mixed flow fans are more efficient than comparably sized tubular centrifugal fans, reducing the required motor horsepower and lowering operating costs.



High Efficiency Low Operating Cost

Operating peak total efficiencies of 76% and FEI levels exceeding 1.0, providing exceptional value. High-efficiency operation lowers operational costs.



Low Sound

Blade design lowers overall sound levels and removes pure tones.



Low Maintenance

Belt drive models have air handling quality bearings for superior operation and long life, while direct drive models remove service needs for belts and fan shaft bearings.



All Weather

Good for indoor and outdoor applications.



Variety of Configurations

Available as inline ducted, roof-mounted upblast, horizontal or vertical and in multiple levels of construction, fitting fan to application.



Applications

Good for supply or exhaust applications, clean or dirty air, or potential hazardous exhaust in difficult environments.

Certifications



Certified data may be found in Greenheck's Computer Aided Product Selection program (CAPS®).

FEI - Fan Energy Index



UL/cUL Listed Power Ventilator
UL/cUL File E40001
UL/cUL 762 Power Ventilators for Restaurant Exhaust Appliances
UL/cUL File MH11745
UL/cUL Power Ventilators for Smoke Control Systems
UL/cUL File MH17511

Angled and contoured blade profiles for the highest efficiency and quiet operation.

Straightening vanes convert rotational airflow into axial flow resulting in static pressure rise and energy savings.

Smooth airflow into the wheel center for optimal performance in unducted or ducted applications.

High efficiency wheel design means lower fan speeds with low sound levels.

No abrupt changes in airflow direction through the wheel and housing improves efficiency.



Arr. 4
Direct drive



Arr. 9
Belt drive

Direct Drive Benefits

- Low maintenance
- Fewer components
- Compact design

Belt Drive Benefits

- Adjustable performance with sheave change
- Broad range of application environments
- Accessible motor
- Long bearing life

Model Comparison

	QEI – Belt Drive			QEID – Direct Drive		
	Series 100	Series 200	Series 300	FJ	Series 100	Series 300
Volume Range	1,100 - 26,000 cfm (1,870 - 44,170 m ³ /hr)	1,100 - 115,000 cfm (1,870 - 195,390 m ³ /hr)	1,100 - 115,000 cfm (1,870 - 195,390 m ³ /hr)	700 - 3,000 cfm (1,190 - 5,100 m ³ /hr)	1,200 - 18,000 cfm (2,040 - 30,600 m ³ /hr)	700 - 83,000 cfm (1,190 - 141,000 m ³ /hr)
Static Pressure	Up to 3 in. wg (750 Pa)	Up to 5 in. wg (1,245 Pa)	Up to 8.5 in. wg (2,120 Pa)	Up to 1 in. wg (250 Pa)	Up to 3.25 in. wg (810 Pa)	Up to 10.5 in. wg (2,370 Pa)
Airflow	Supply and Exhaust	Supply and Exhaust	Supply and Exhaust	Exhaust	Supply and Exhaust	Supply and Exhaust
Construction	Welded	Welded	Welded	Bolted	Bolted	Welded
Mounting	Mounting Brackets	Mounting Brackets	Mounting Brackets	Flange Mounted	Mounting Brackets	Mounting Brackets
Environment	Indoor / Outdoor	Indoor / Outdoor	Indoor / Outdoor	Indoor Only	Indoor / Outdoor	Indoor / Outdoor
Roof Upblast		✓	✓			✓
UL 705 Supplement SD - Electrical	✓	✓	✓	✓	✓	✓
UL Emergency Smoke Evacuation		✓	✓			✓
UL 705 Supplement SC - Restaurant Exhaust		✓	✓			
Spark Resistance	A, B or C	B or C	B or C	A		
Aluminum Construction	✓					
Seismic Certification			✓			
Assembly Vibration Tested*	✓ 0.2 in./sec	0.15 in./sec	0.15 in./sec		✓ 0.2 in./sec	0.08 in./sec

✓ = *Optional*

* = *Peak, Filter-in as measured at the fan RPM*

Series indicates different levels of construction and performance. Fan capacity and structural integrity increase as the series increases. This approach provides the best value for each project.

Series

100
QEID FJ



QEID FJ

Return, exhaust or supply air in office buildings, hospitals, schools and data centers.



QEID-100

Low sound air movement in libraries, concert halls and dormitories.

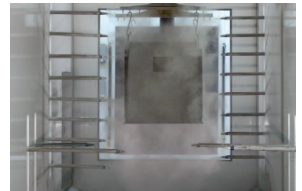

200

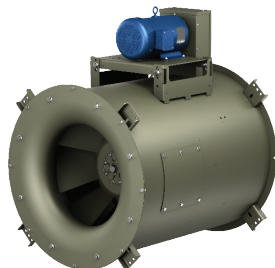

QEI-100

Industrial process exhaust in manufacturing facilities, paint systems, and utility plants.

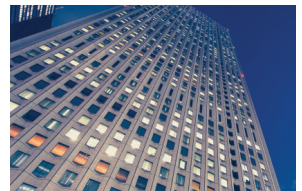

QEI-200, 300

Life safety applications including emergency smoke exhaust and stairwell pressurization; restaurant kitchen grease; hazardous or flammable airstreams.



300



QEID-300



Standard Construction & Accessories

		QEI 100	QEI 200	QEI 300	QEID 100	QEID 300	QEID FJ
Housing Finish	Greenheck's Permator™ coating is an electrostatically applied thermosetting polyester urethane. Permator coatings provide excellent corrosion characteristics for general indoor and outdoor applications.	Std.	Std.	Std.	Galvanized Standard ✓	Std.	Galv Std.
Extended Lube Lines	Lubrication lines with grease fittings mounted to the fan exterior that allow bearings (QEI) or motor (QEID), if required, lubrication without accessing internal drive components.	Std.	Std.	Std.	✓	Std.	Sealed
Adjustable Motor Bases	Motor bases are welded to the fan housing and include adjustment screws for belt tensioning.	Std.	Std.	Std.			
Motor Cover	Shields the motor components from dust, dirt, and moisture for indoor or outdoor installations. Also, serve as a personnel guard and meet OSHA standards.	✓	✓	✓			
Belt Guard	A totally enclosed belt guard, per OSHA standards, provides protection from rotating pulleys and belts.	✓	✓	✓			
Extended Wiring	Electric wiring leads from the motor are brought to the outside of the unit's exterior for easy wiring connection. Option for no extended wiring.				Std.	Std.	Std.
Bolted Access Door	Access door for cleaning or visual inspection of the wheel.	Std.	Std.	Std.	Std.	Std.	
Extended Life Bearings	Air handling quality bearings meet a basic rating fatigue life L ₁₀ per ABMA standards, in excess of 200,000 hours (L ₅₀ at 1,000,000) at maximum operating speed.		✓	✓			
Flanges	Inlet and outlet flanges, with prepunched holes welded to the housing, provide an easy means for bolted connection to ductwork. Bolt-on companion flanges also available.	Std.	✓	✓	Std.	✓	Std.
Disconnect Switches	Toggle-type and heavy-duty disconnect switches for positive electrical shut-off and safety when servicing fans.	✓	✓	✓	✓	✓	
Inlet and Outlet Guards	Removable inlet and outlet guards provide protection for personnel and equipment in ducted or non-ducted installations.	✓	✓	✓	✓	✓	
Belt Tube	A totally enclosed belt tube isolates the belts and drives from the airstream.	✓	✓	✓			
Mounting Rails	Mounting rails are recommended for vertically mounted fans or horizontal mounting when the motor is to be located in the B, C, D, F, G or H position.	✓	✓	✓			
Isolators	Base mount and hanging isolators are available in either neoprene or spring mounts.	✓	✓	✓	✓	✓	
Special Coatings	Special coatings are available for protective purposes.	✓	✓	✓	✓	✓	
Sure-Aire™	Determine airflow using pressure differential between piezometer ring and fan inlet. No performance loss. Digital electronics option provides local readout and communication output.	✓	✓	✓	✓	✓	

✓ = *Optional*

Belt Drive

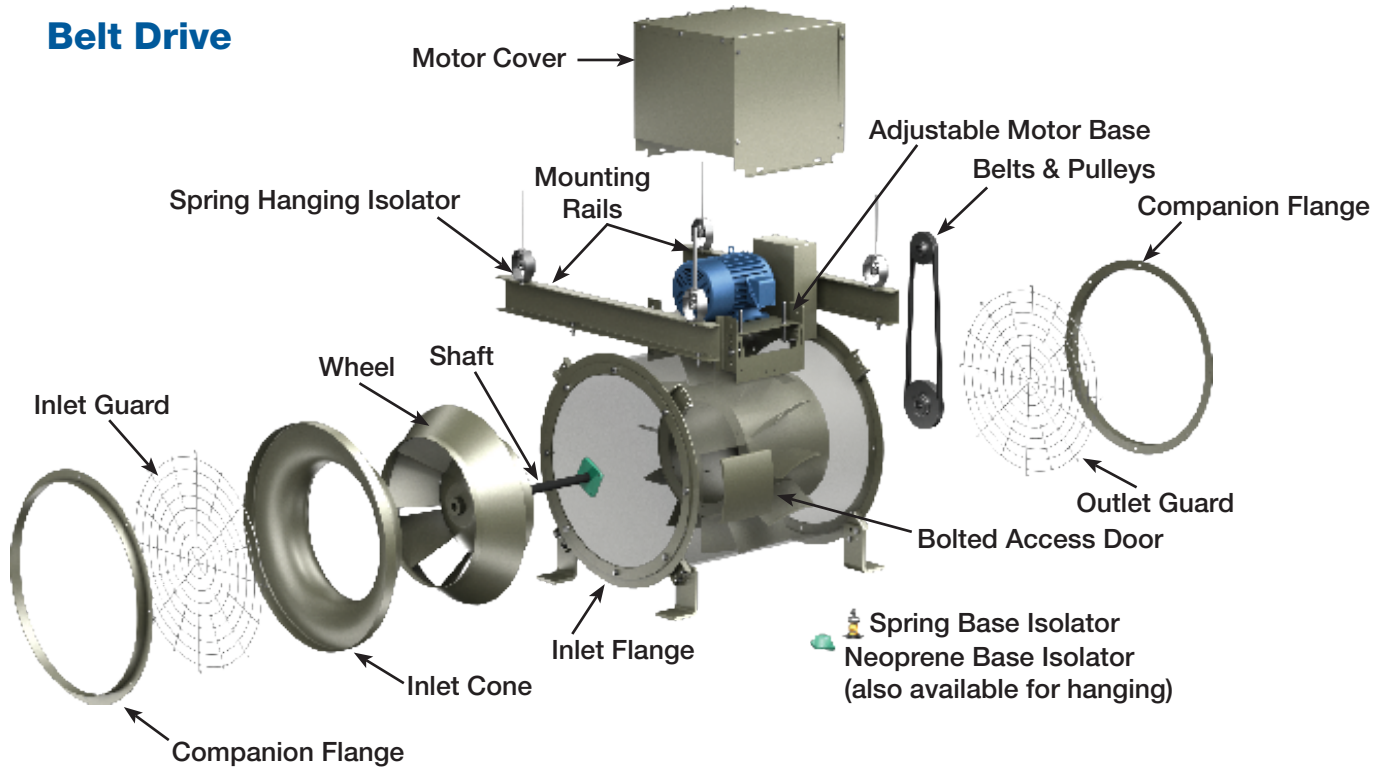

Direct Drive

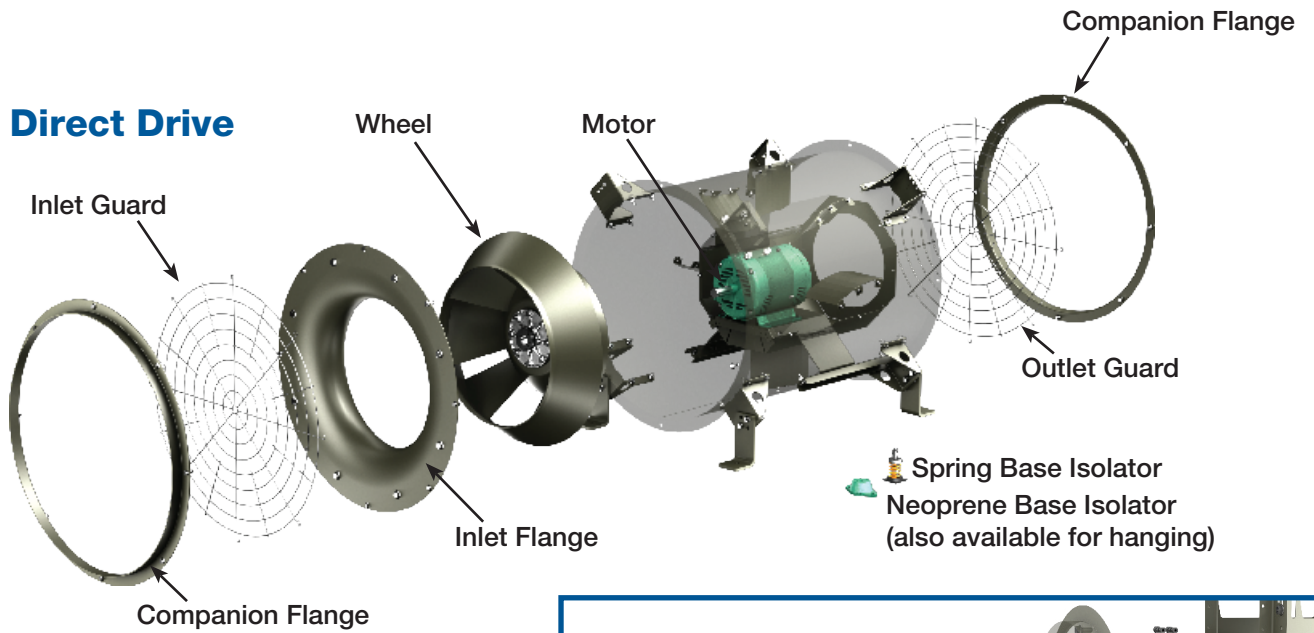

UL705 Supplement SC Restaurant Exhaust

Inline grease exhaust fans are an excellent alternative for kitchen applications when roof or wall-mounted ventilators are not practical.

Designed to withstand the demands of high temperature kitchen grease exhaust and high-pressure duct washers.

Available on QEI-200, 300



- UL/cUL Power Ventilators for Restaurant Exhaust Appliances
- Meets requirements of NFPA 96 Ventilation Control and Fire Protection of Commercial Cooking Operations

UL Emergency Smoke Evacuation

QEI and QEID models were tested and rated for design time and temperature used in emergency heat and smoke exhaust applications.

Available on QEI-200, 300, QEID-300

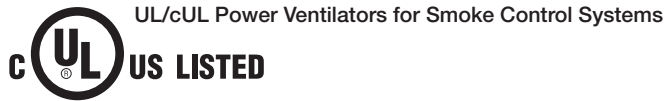

Model	Operating Temperature		Time Duration	Comments
	°C	°F	Hours	
QEID	300	572	1	Per British Spec 7346
QEI	300	572	2	
QEI	260	500	4	Per Industrial Risk Insurers (North America)
QEID	260	500	4	

Seismic

The International Building Code (IBC) has been adopted at the state and local level throughout the United States. With the adoption of this code comes the introduction of standards intended to improve the performance and design of nonstructural systems subject to seismic events.

Available on QEI-300

- Meet the IBC seismic requirements
- California HCAI, formerly OSHPD, pre-approved (horizontal mount only)
- Shake table tested at an independent test facility
- All equipment certified to worst-case scenario seismic conditions

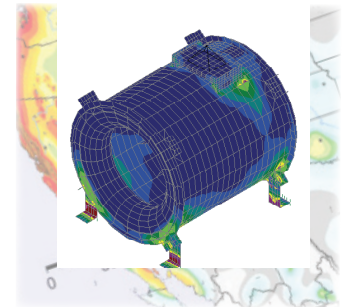

Structural Finite Element Analysis
Seismic Design Category F

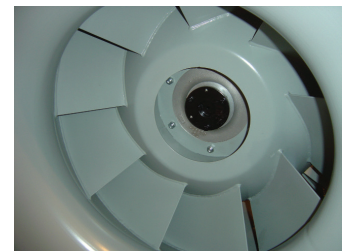
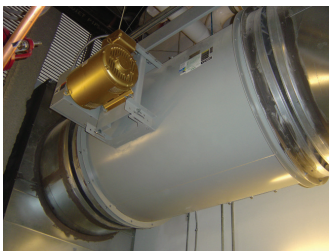

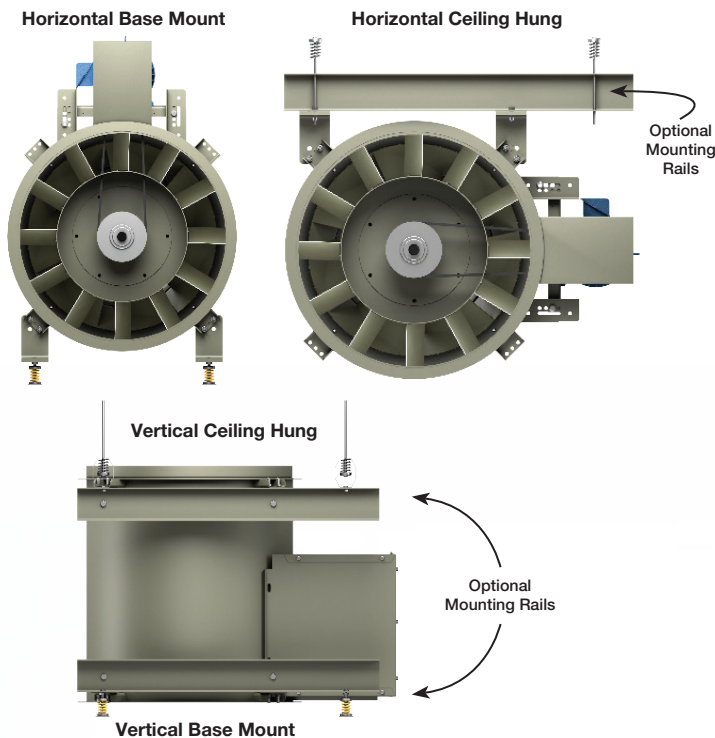

Series 100 (All Sizes) Series 200 & 300 (Sizes 9-27) Universal Mounting

Brackets on belt or direct drive models are used for either horizontal or vertical mounting. For ease of installation, motor or junction box positions can be changed in the field for better access to components, solve fit issues, or avoid electrical trays and piping.

Mounting rails are suggested for any vertical installation and horizontal installations with motor positions C or G (3 or 9 o'clock). Motor positions as viewed from the discharge end.

Motor Mounting Positions

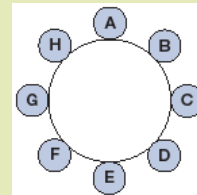

Motor Positions As Viewed From Outlet End

Series 200 & 300 (Sizes 30-60)

Horizontal Mounting

Horizontal mounting configurations, base mount or ceiling hung, are provided with an identical support. The mounting configuration can be changed between base mount or ceiling hung in the field.

Mounting rails are recommended for installations B, C, D, F, G or H positions. Motor positions as viewed from the discharge end.

Vertical Mounting

Vertical mounting configurations, upblast or downblast, are provided with heavy-duty steel brackets welded to both ends. These brackets permit either floor or ceiling mounting on the same unit.

Roof Upblast

Ideal for exhausting contaminants away from a building to prevent roof damage and re-entrainment of exhaust air. Available with high temperature UL rating and can be used for emergency smoke exhaust applications.

- Fully-welded heavy-gauge curb cap to eliminate leaks
- Butterfly damper section included for backflow prevention
- Windband section to protect the butterfly dampers from debris

Available on QEI-200, 300, QEID-300



Electronics and Controls

Variable Frequency Drives (VFD)

Greenheck provided VFDs get systems up and running quickly. Each drive is sized, configured, and programmed for operation at the specified performance.

Easy-to-use touch pad allows for speed adjustment

- Simple menu screen to scroll through
- Quick and easy system balancing
- No time-consuming or additional costs for belt drive sheave changes

Advantages of Greenheck supplied VFD

- VFD factory sized for amperage by fan-selected horsepower and operating voltage
- Pre-programmed at the factory
 - Personalized menu structure for the most commonly adjusted items
 - Motor information (HP, voltage, line Hz, nominal speed)
 - Maximum Hz limited to that of motor hp, or by fan construction
 - Programmed PID loop for operation with constant pressure or volume, if option selected, to maintain set point
 - Quick and easy to understand installation guide and troubleshooting video
 - Ships separate for choice between remote mounting for easy access or near the fan as needed
- Motor configured and compatible for use with a VFD

Best value choice with multiple VFDs available based on location and application.



Installation Location	Enclosure Rating	Overload Protection Available	External Communication Available	Additional Control Options	Factory Pre-programmed	Touch Screen Speed Control
Indoor	NEMA 1	✓	✓	Constant Pressure or Constant Volume	Yes	Yes
Indoor / Outdoor	NEMA 3R or 4X	✓	✓	(indoor and indoor / outdoor)	Yes	Yes

✓ = *Optional*

Available on QEI, QEID

Vari-Green® Electronically Commutated (EC) Motors

Greenheck's EC Vari-Green motor combines motor technology, controllability and energy-efficiency into one single low-maintenance unit.

- 80% usable turndown
- No speed controller to wire, 0-10 volt control wires pre-installed in motor
- No maintenance required
- No belt and pulley losses
- High-efficiency operation

Available on QEID-100, QEID FJ



Spark-Resistant Construction

Spark-resistant designs suitable for applications that involve flammable particles, fumes or vapors. Spark-resistant construction options adhere to guidelines defined within AMCA Standard 99-0401.

Available on QEI-100, 200, 300, QEID-FJ

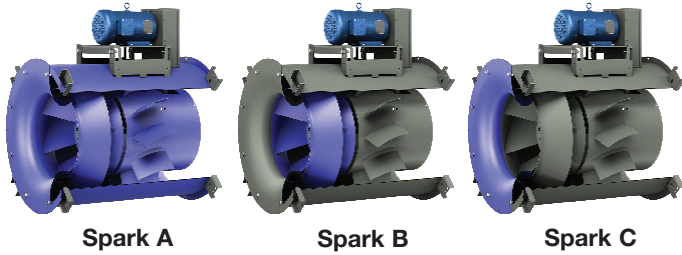

Spark A	The inlet cone, fan wheel, housing, inner chamber and fasteners are constructed of a nonferrous material.
Spark B	The fan wheel is constructed of a nonferrous material (aluminum). A nonferrous (aluminum) bearing cover surrounds the driven bearing, shielding it from the airstream.
Spark C	The inlet cone is constructed of nonferrous material (aluminum). A nonferrous (aluminum) bearing cover surrounds the driven bearing shielding it from the airstream.

Copolymer with Spark A

Safely exhaust low flow applications containing odorous air, fumes, chemicals or contaminants. To address these environments, the QEID FJ utilizes a durable copolymer composite material that resists a wide range of chemicals plus has a completely spark-proof nonferrous airstream. The motor and wiring are enclosed in a sealed compartment that protects these components from coming in contact or being exposed to airstream contaminants. Construction meets Spark A resistant rating.

Available on QEID FJ

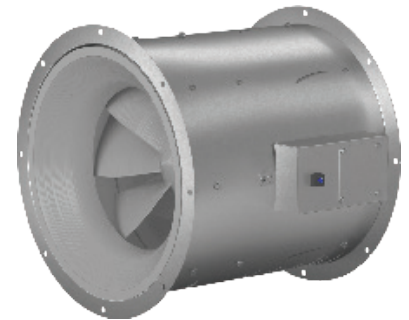

All Aluminum Construction

Commonly used in applications involving moisture or high humidity levels for either the airstream or mounting environment. Aluminum forms a hard and durable oxide layer that is resistant to corrosion. It is highly resistant to weathering even in industrial atmospheres that often corrode other metals. Available with Greenheck's full range of powder coatings for additional corrosion protection.

* Primary airstream components are constructed from aluminum. Design has zinc-plated fasteners and steel fan shafting.

Available on QEI-100



Model Number Nomenclature

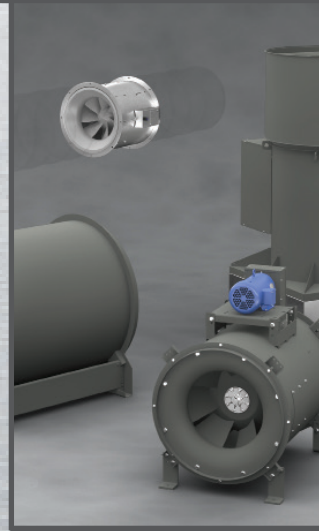
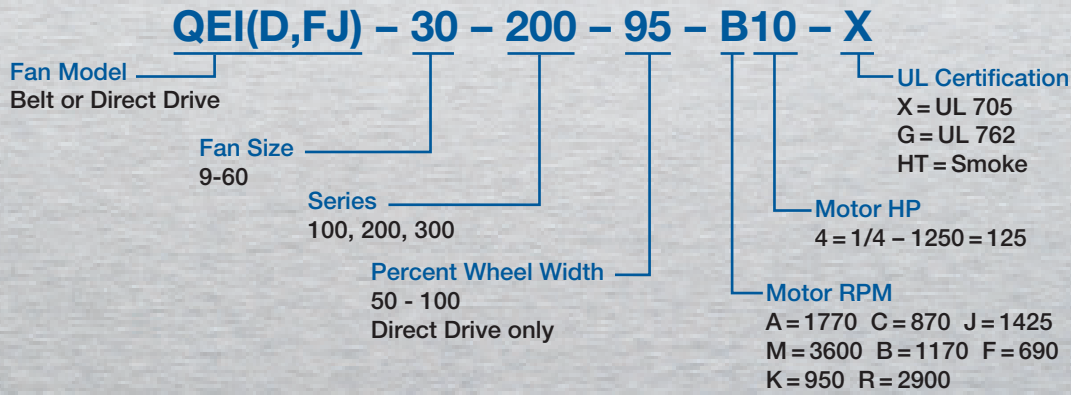

Value Added Features

Software Selection Tools

- CAPS®
- eCAPS®



Quality Assurance Testing

- Wheel balance
- Motor amps
- Assembly vibration



Electrostatic Powder Coatings

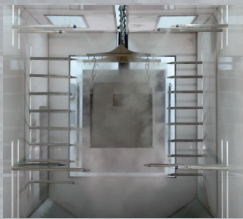

AutoCAD and 3D Revit® Models

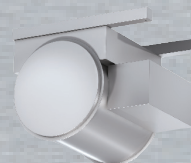
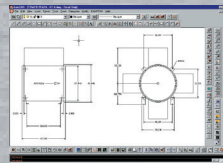

Our Commitment

As a result of our commitment to continuous improvement, Greenheck reserves the right to change specifications without notice.

Product warranties can be found online at Greenheck.com, either on the specific product page or in the literature section of the website at Greenheck.com/Resources/Library/Literature.

