

**PRICE® MODEL CA-XAD-6
COMBINATION LOUVER
DRAINABLE BLADE. AMCA LICENSED.**



Standard Construction:

- Frame:** 6" x .080 (152 mm x 2.0 mm) extruded aluminum (6063-T5).
- Stationary Blades:** .081 (2.1 mm) extruded aluminum (6063-T5) approximately 4-1/2" (114 mm) on centers.
- Adjustable Blades:** .125 (3.2 mm) extruded aluminum (6063-T5).
- Blade Angle:** 37.5°
- Bearings:** Permanently lubricated oilite bronze, press fit into frame.
- Axles:** 3/8" (9.5 mm) square plated steel.
- Linkage:** Plated steel, concealed in jamb.
- Operator:** Wing nut side bracket.
- Blade Seals:** Extruded Vinyl.
- Jamb Seals:** Flexible stainless steel.
- Screen:** Bird screen - 3/4" x .050 (19 mm x 12.7 mm) flattened expanded aluminum in a removable frame on interior of louver.
- Finish:** Mill aluminum.
- Minimum Section Size:** 12"w x 12"h (25.4 mm x 25.4 mm)
- Maximum Section Size:** 48"w x 72"h (1219 mm x 1829 mm)

Options:

- Screens:** Insect screen - 18 x 16 mesh aluminum.
Other: _____
- Finish:** Prime Coat.
Baked Enamel.
Clear Anodize - 204-R1 & 215-R1.
Integral Color Anodize
Kynar 500 Enamel.
Other: _____
- Sill Extensions:**
- Flange:** 1-1/2" (38 mm) (front or rear)
- Frame:** .125 (3.2 mm) Extruded Aluminum
- Stationary Blade:** .125 (3.2 mm) Extruded Aluminum
- Other Operator** - _____

Notes: Louvers fabricated 1/4" (6.4 mm) under opening size unless otherwise noted.

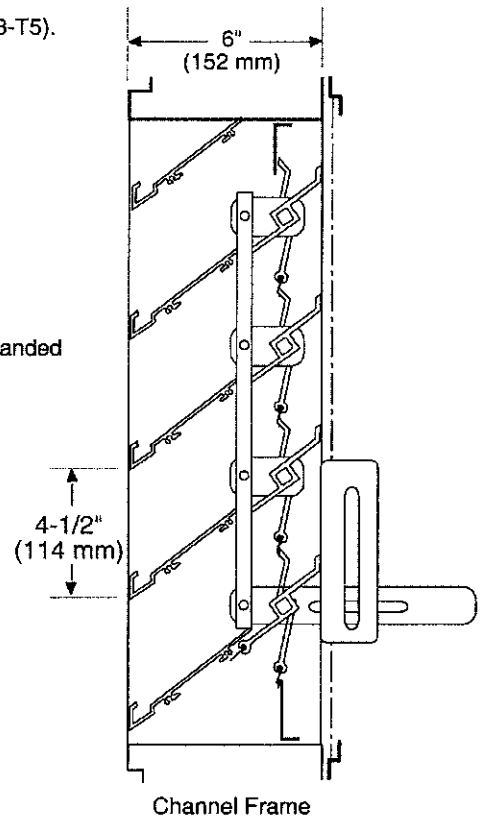

CA-XAD-6 - 07-05

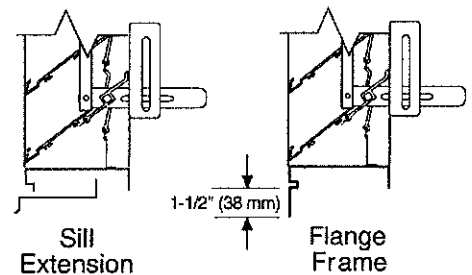
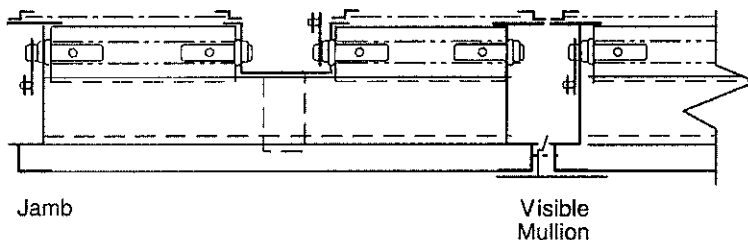

Specifications are correct at time of printing. However, as part of our 'continuous improvement program,' we reserve the right to make further improvements without notice. © JULY, 2005 PRICE

Project:	Contractor:
Location:	Address:
Architect:	P.O. Number:
Engineer:	Date:

PRICE® MODEL CA-XAD-6 LOUVER PERFORMANCE DATA COMBINATION STATIONARY / ADJUSTABLE BLADE EXTRUDED ALUMINUM. AMCA LICENSED.

© JULY, 2005 PRICE

Specifications

Furnish and install where shown model **CA-XAD-6** louver, manufactured by **PRICE**. Louvers shall be the **combination drainable** type with a frame depth of **6 inches**. Frames and stationary shall be .081 inches thick 6063-T5 extruded aluminum alloy. Adjustable blades to be .125 inches thick 6063-T5 extruded aluminum alloy. Blades shall be located on a **37-1/2 degree** blade angle. Screens shall consist of 3/4" expanded aluminum, with an extruded frame, mounted to the louver interior, and be removable for cleaning. Louvers shall be finished with Polyurethane Acrylic enamel, Kynar 500, Anodize or other finishes selected by the architect from PRICE standard color charts.

CA-XAD-6 Free Area in Sq. Ft.

		Width - Inches														
		12	18	24	30	36	42	48	54	60	66	72	78	84	90	96
Height - Inches	12	.22	.37	.52	.67	.81	.96	1.11	1.26	1.41	1.56	1.71	1.86	2.01	2.16	2.31
	18	.44	.75	1.05	1.35	1.66	1.96	2.26	2.38	2.68	2.98	3.29	3.59	3.89	4.20	4.50
	24	.66	1.11	1.57	2.02	2.47	2.93	3.38	3.75	4.23	4.70	5.18	5.66	6.14	6.62	7.10
	30	.84	1.42	2.00	2.58	3.16	3.74	4.32	4.53	5.11	5.69	6.27	6.85	7.43	8.01	8.58
	36	1.10	1.85	2.61	3.36	4.11	4.87	5.62	5.91	6.66	7.41	8.17	8.92	9.67	10.43	11.18
	42	1.31	2.21	3.12	4.02	4.92	5.82	6.72	7.28	8.21	9.13	10.06	10.99	11.92	12.85	13.78
	48	1.50	2.53	3.56	4.59	5.62	6.65	7.68	8.06	9.09	10.12	11.15	12.18	13.21	14.24	15.27
	54	1.76	2.96	4.16	5.37	6.57	7.78	8.98	9.43	10.64	11.84	13.05	14.25	15.46	16.66	17.86
	60	1.93	3.26	4.58	5.91	7.23	8.56	9.89	10.38	11.71	13.03	14.36	15.68	17.01	18.34	19.66
	66	2.16	3.64	5.12	6.60	8.08	9.56	11.04	11.59	13.07	14.55	16.03	17.51	18.99	20.47	21.95
	72	2.38	4.07	5.72	7.39	9.03	10.69	12.34	12.96	14.62	16.27	17.93	19.58	21.24	22.89	24.55
	78	2.56	4.31	6.07	7.82	9.58	11.34	13.09	13.75	15.50	17.26	19.01	20.77	22.52	24.28	26.03
	84	2.81	4.75	6.68	8.61	10.54	12.47	14.40	15.12	17.05	18.98	20.91	22.84	24.77	26.70	28.63
	90	3.04	5.12	7.20	9.28	11.37	13.45	15.53	16.49	18.60	20.70	22.81	24.91	27.02	29.12	31.23
	96	3.22	5.42	7.63	9.83	12.04	14.24	16.45	17.28	19.48	21.69	23.89	26.10	28.30	30.51	32.72

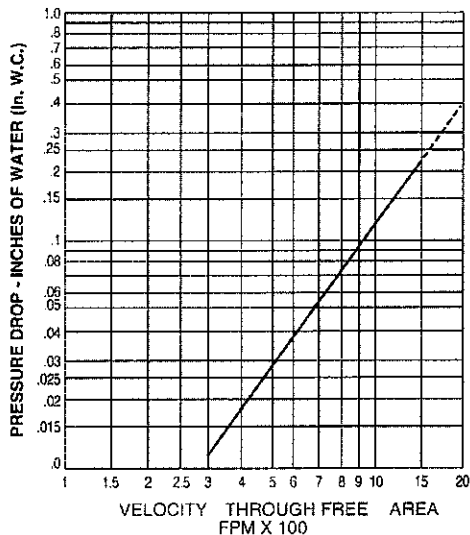

PRESSURE DROP INTAKE
(Test Size 48" x 48")

E.H. PRICE Limited, Inc. certifies that the Model CA-XAD-6 louver shown herein is licensed to bear the AMCA seal. The ratings shown are based on tests and procedures performed in accordance with AMCA Publication 511 and comply with the requirements of the AMCA Certified Ratings program.

The AMCA Certified Seal applies to air performance ratings and water penetration ratings.

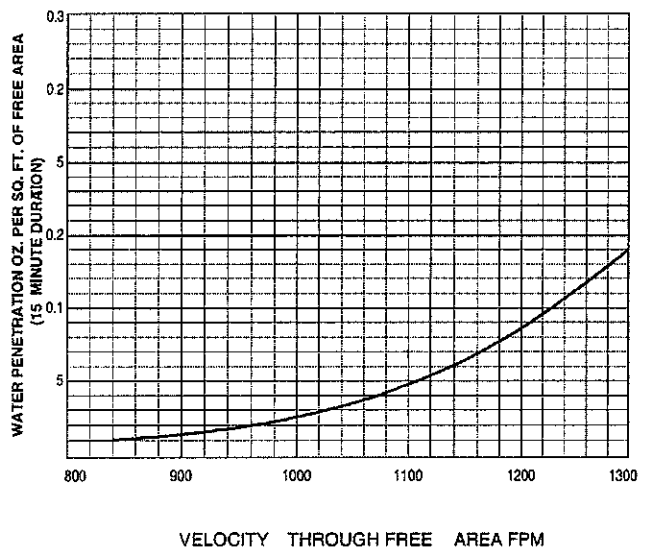

Water Penetration

Water Penetration Data applies to test unit size 48" x 48" only. Beginning of Water Penetration is 840 FPM Free Area Velocity. Performance shown is at standard air density 0.075 lbs./ft³.