

PRICE

**MODEL XAZ-4
EXTRUDED ALUMINUM LOUVER
STEP BLADE. AMCA LICENSED.**



Standard Construction:

- Frame:** 4" x .081 (101 mm x 2.1 mm) extruded aluminum (6063-T5).
- Blades:** .081 (2.1 mm) extruded aluminum (6063-T5), approximately 4-3/8" (111 mm) on centers.
- Blade Angle:** 45 °
- Screen:** Bird screen - 3/4" x .050 (19 mm x 12.7 mm) flattened expanded aluminum in a removable frame on interior of louver.
- Finish:** Mill aluminum.
- Minimum Size:** 12"w x 12"h (304 mm x 304 mm)

Options:

- Screens:** Insect screen - 18 x 16 mesh aluminum
Other - _____
- Finish:** Prime Coat
Baked Enamel
Clear Anodize - 204-R1 and 215-R1
Integral Color Anodize
Kynar 500 Enamel
Other - _____
- Sill Extensions:**
 - Flange:** 1-1/2" (38 mm) (front or rear)
 - Frame:** .125 (3.2 mm) Extruded Aluminum
- Notes:** Louvers fabricated 1/4" (6.4 mm) under opening size unless otherwise noted.

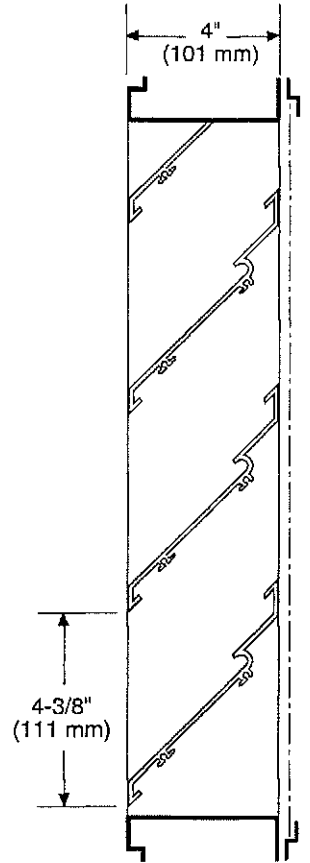

Channel Frame

XAZ-4 - 07-05

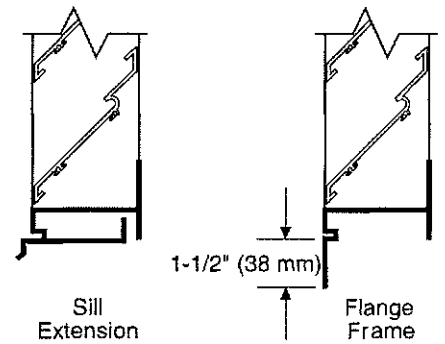
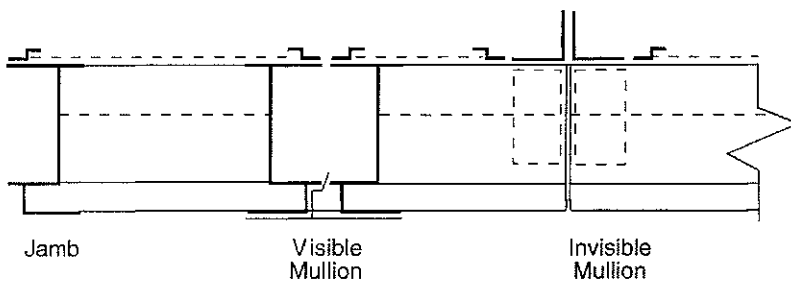

Specifications are correct at time of printing. However, as part of our 'continuous improvement program,' we reserve the right to make further improvements without notice.

© JULY, 2005 PRICE

Project:	Contractor:
Location:	Address:
Architect:	P.O. Number:
Engineer:	Date:



MODEL XAZ-4
LOUVER PERFORMANCE DATA
 STEP BLADE .EXTRUDED ALUMINUM. AMCA LICENSED.

© JULY, 2005 PRICE

Specifications

Furnish and install where shown model XAJ-4 louver, manufactured by PRICE. Louvers shall be the stationary straight type with a frame depth of **4 inches**. Frames and blades shall be .081 inches thick 6063-T5 extruded aluminum alloy. Blades shall be located on a **45 degree** blade angle. Screens shall consist of 3/4" expanded aluminum, with an extruded frame, mounted to the louver interior, and be removable for cleaning. Louvers shall be finished with Polyurethane Acrylic enamel, Kynar 500, Anodize or other finishes selected by the architect from PRICE standard color charts.

XAZ-4 Free Area in Sq. Ft.

Width - Inches

Height - Inches	12	18	24	30	36	42	48	54	60	66	72	78	84	90	96
12	.17	.29	.41	.53	.65	.77	.89	1.01	1.13	1.25	1.37	1.46	1.58	1.70	1.82
18	.36	.61	.86	1.11	1.35	1.60	1.85	2.10	2.34	2.59	2.84	3.03	3.27	3.52	3.77
24	.58	.97	1.37	1.76	2.16	2.55	2.95	3.34	3.74	4.13	4.53	4.82	5.22	5.61	6.01
30	.71	1.20	1.69	2.18	2.67	3.16	3.64	4.13	4.62	5.11	5.60	5.95	6.45	6.94	7.43
36	.94	1.58	2.22	2.87	3.51	4.15	4.79	5.44	6.08	6.72	7.37	7.85	8.49	9.13	9.78
42	1.12	1.89	2.66	3.43	4.20	4.97	5.74	6.51	7.28	8.04	8.81	9.39	10.16	10.93	11.70
48	1.28	2.16	3.03	3.91	4.78	5.65	6.54	7.41	8.29	9.17	10.04	10.70	11.58	12.46	13.33
54	1.51	2.55	3.59	4.63	5.67	6.70	7.74	8.78	9.82	10.85	11.89	12.67	13.71	14.75	15.78
60	1.67	2.81	3.95	5.10	6.24	7.38	8.53	9.67	10.81	11.96	13.10	13.96	15.10	16.24	17.39
66	1.85	3.13	4.40	5.67	6.94	8.21	9.48	10.76	12.03	13.30	14.57	15.52	16.80	18.07	19.34
72	2.08	3.50	4.92	6.35	7.77	9.20	10.62	12.04	13.47	14.89	16.32	17.38	18.81	20.23	21.66
78	2.21	3.73	5.25	6.77	8.28	9.80	11.32	12.84	14.35	15.87	17.39	18.53	20.04	21.56	23.08
84	2.43	4.10	5.76	7.43	9.10	10.76	12.43	14.10	15.76	17.43	19.10	20.35	22.01	23.68	25.35
90	2.62	4.42	6.22	8.02	9.81	11.61	13.41	15.21	17.01	18.81	20.60	21.95	23.75	25.55	27.35
96	2.77	4.67	6.57	8.47	10.37	12.27	14.17	16.00	17.97	19.87	21.76	23.19	25.09	26.99	28.89

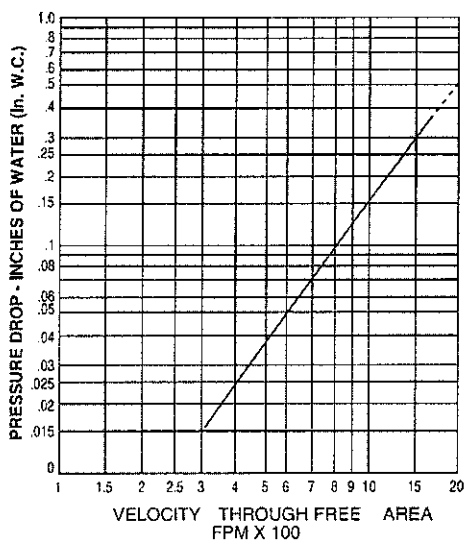

PRESSURE DROP INTAKE
 (Test Size 48" x 48")

E.H. PRICE Limited, Inc. certifies that the Model XAJ-4 louver shown herein is licensed to bear the AMCA seal. The ratings shown are based on tests and procedures performed in accordance with AMCA Publication 511 and comply with the requirements of the AMCA Certified Ratings program. The AMCA Certified Seal applies to air performance ratings and water penetration ratings.

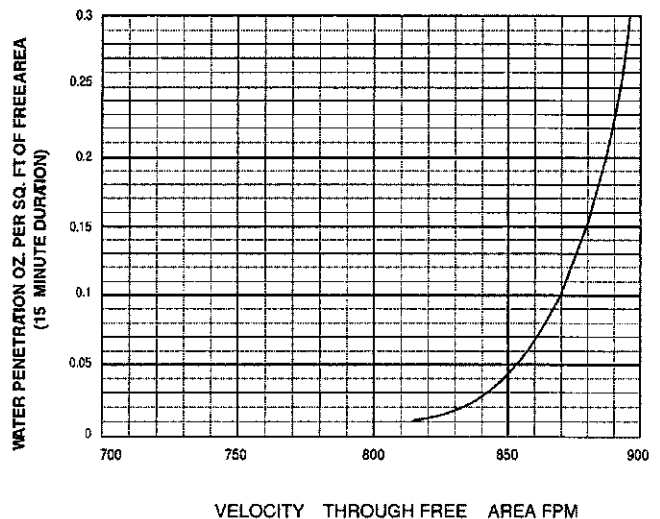

Water Penetration

Water Penetration Data applies to test unit size 48" x 48" only. Beginning of Water Penetration is 814 FPM Free Area Velocity. Performance shown is at standard air density 0.075 lbs./ft³.