

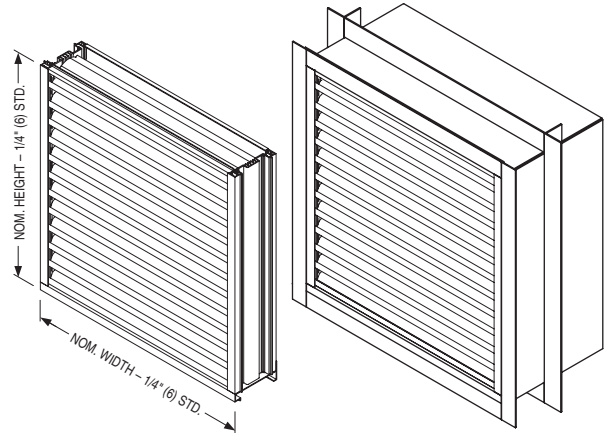

**EXTRUDED ALUMINUM STATIONARY LOUVER**  
**MIAMI-DADE QUALIFIED • FLORIDA PRODUCT APPROVED**  
**WIND-DRIVEN RAIN RESISTANT**  
**5" (127) DEEP • HORIZONTAL BLADE**  
**MODEL: 1605WDM**

**QUALIFICATIONS:**

- Miami-Dade County NOA No. : 23-0724.24
- Florida Product Approval No. 28078.1
- Texas Department of Insurance Evaluation ID: LVR-28
- Tested in accordance with: TAS-201 (Large Missile Impact Test), TAS-202 (Uniform Static Air Pressure Test), TAS-203 (Cyclic Wind Pressure Loading Test), TAS-100A (Wind-Driven Rain Test [with optional Model 2020 damper in closed position]).
- AMCA 500-L (Wind-Driven Rain, Water Penetration, Air Performance).
- AMCA 540 (Wind-Borne Debris Impact Test [Enhanced "Level E" Protection]).
- AMCA 550 (High Velocity Wind-Driven Rain Resistance Test [with optional Model 2020 damper in closed position]).
- Wind load rating +/- 150 PSF.



**STANDARD CONSTRUCTION:**

- FRAME:** 5" (127) deep, Type 6063-T6 extruded aluminum, .080" (2.03) nominal wall thickness. Integral downspouts and caulking slot provided.
- BLADES:** Type 6063-T6 extruded aluminum, .080" (2.03) nominal wall thickness, with reinforcing bosses.
- BLADE ANGLE:** Fixed at 30 degrees.
- BLADE SPACING:** 1.86" (47) on centers.
- BLADE SUPPORT:** Concealed type, factory installed on rear of louver. Reinforced with 2" x 2" (51 x 51) angle (adds approximately 2" [51] to overall louver depth).
- SCREEN:** 3/4" x .050 (19 x 1.27) expanded, flattened aluminum bird screen in removable frame, inside (rear) mount (adds approx. 3/8" [10] to louver depth).
- FINISH:** Mill.
- MINIMUM SIZE:** 12" W x 12" H (305 x 305).
- MAX. SINGLE** 72" W x 120" H (1829 x 3048). 60 sq. ft. (5.6 m<sup>2</sup>)
- SECTION SIZE:** (36" W x 120" H [914 x 3048] with optional Model 2020 damper). Larger louvers will require field assembly of smaller sections.
- MAXIMUM SIZE:** Unlimited Width x 120" H (3048).

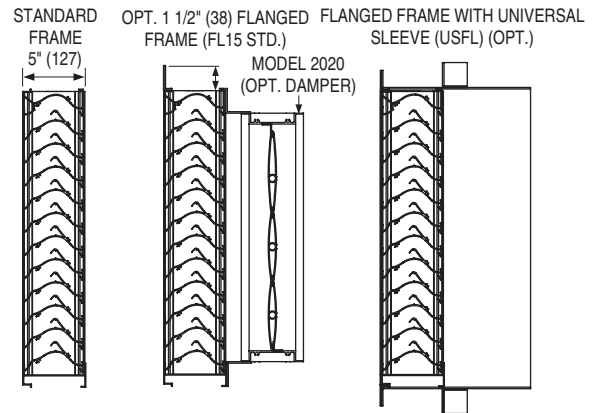

**OPTIONS:**

- FL15** Flanged Frame, 1 1/2" (38).
- FL20** Flanged Frame, 2" (51).
- USFL** Universal Sleeve/Flanged Frame.
- BSSS** Type 304 S.S. Bird Screen.
- BSN** No Bird Screen.
- ISA** Aluminum Insect Screen.
- ISSS** Type 304 S.S. Insect Screen.
- ESI** Extended Sill.
- PASI** Sill Pan.
- Other: \_\_\_\_\_.

**OPTIONAL FINISHES:**

- PC3** Powder Coat AAMA 2603. Color: \_\_\_\_\_.
- PC4** High Performance Powder Coat AAMA 2604 (Equivalent to 50% Kynar®). Color: \_\_\_\_\_.
- PC5** Fluoropolymer Powder Coat AAMA 2605 (Equivalent to 70% Kynar®). Color: \_\_\_\_\_.
- PCC** Prime Coat.
- AN04** Clear Anodized 204-R1.
- AN15** Clear Anodized 215-R1.
- ANLB** Light Bronze.

- ANMB** Medium Bronze.
- ANDB** Dark Bronze.
- ANBK** Black.

**OPT. FACTORY MOUNTED 2020 CONTROL DAMPER:**

- Extruded Aluminum
- Opposed Airfoil Blades
- Concealed Linkage
- Silicone Blade Seal
- Cambered Stainless Steel Jamb Seals
- 1/2" (13) Plated Steel Axles

<b>SCHEDULE TYPE:</b>	For Installation Instructions, see approved NOA. Page 1 of 3 Dimensions are in inches (mm).			
<b>PROJECT:</b>				
<b>ENGINEER:</b>	<b>DATE</b>	<b>B SERIES</b>	<b>SUPERSEDES</b>	<b>DRAWING NO.</b>
<b>CONTRACTOR:</b>	7 - 31 - 24	1600M	1 - 30 - 24	1605WDM



**EXTRUDED ALUMINUM STATIONARY LOUVER**  
**MIAMI-DADE QUALIFIED • FLORIDA PRODUCT APPROVED**  
**WIND-DRIVEN RAIN RESISTANT**  
**5" (127) DEEP • HORIZONTAL BLADE • PERFORMANCE DATA**  
**MODEL: 1605WDM**

**FREE AREA in Square Feet and Square Meters**

		Width in Inches and Meters										
		12	18	24	30	36	42	48	54	60	66	72
		0.30	0.46	0.61	0.76	0.91	1.07	1.22	1.37	1.52	1.68	1.83
Height in Inches and Meters	12	0.27	0.43	0.60	0.76	0.93	1.09	1.26	1.42	1.59	1.75	1.92
	0.30	0.03	0.04	0.06	0.07	0.09	0.10	0.12	0.13	0.15	0.16	0.18
	18	0.47	0.76	1.05	1.34	1.63	1.92	2.20	2.49	2.78	3.07	3.36
	0.46	0.04	0.07	0.10	0.12	0.15	0.18	0.20	0.23	0.26	0.29	0.31
	24	0.74	1.19	1.65	2.10	2.56	3.01	3.46	3.92	4.37	4.82	5.28
	0.61	0.07	0.11	0.15	0.20	0.24	0.28	0.32	0.36	0.41	0.45	0.49
	30	0.94	1.52	2.10	2.68	3.25	3.83	4.41	4.99	5.56	6.14	6.72
	0.76	0.09	0.14	0.19	0.25	0.30	0.36	0.41	0.46	0.52	0.57	0.62
	36	1.15	1.85	2.55	3.25	3.95	4.65	5.35	6.05	6.76	7.46	8.16
	0.36	0.11	0.17	0.24	0.30	0.37	0.43	0.50	0.56	0.63	0.69	0.76
	42	1.35	2.17	3.00	3.82	4.65	5.47	6.30	7.12	7.95	8.77	9.60
	1.07	0.13	0.20	0.28	0.36	0.43	0.51	0.59	0.66	0.74	0.81	0.89
	48	1.62	2.61	3.60	4.59	5.58	6.57	7.59	8.55	9.54	10.53	11.52
	1.22	0.15	0.24	0.33	0.43	0.52	0.61	0.71	0.79	0.89	0.98	1.07
	54	1.82	2.93	4.05	5.16	6.27	7.39	8.50	9.62	10.73	11.84	12.96
	1.37	0.17	0.27	0.38	0.48	0.58	0.69	0.79	0.89	1.00	1.10	1.20
60	2.02	3.26	4.50	5.73	6.97	8.21	9.45	10.68	11.92	13.16	14.40	
1.52	0.19	0.30	0.42	0.53	0.65	0.76	0.88	0.99	1.11	1.22	1.34	
66	2.22	3.58	4.95	6.31	7.67	9.03	10.39	11.75	13.11	14.47	15.84	
1.68	0.21	0.33	0.46	0.59	0.71	0.84	0.97	1.09	1.22	1.34	1.47	
72	2.49	4.02	5.55	7.07	8.60	10.12	11.65	13.18	14.70	16.23	17.76	
1.83	0.23	0.37	0.52	0.66	0.80	0.94	1.08	1.22	1.37	1.51	1.65	
78	2.7	4.35	6.00	7.65	9.30	10.95	12.6	14.25	15.90	17.55	19.20	
1.98	0.25	0.40	0.56	0.71	0.86	1.02	1.17	1.32	1.48	1.63	1.78	
84	2.9	4.67	6.44	8.22	9.99	11.77	13.54	15.31	17.09	18.86	20.63	
2.13	0.27	0.43	0.60	0.76	0.93	1.09	1.26	1.42	1.59	1.75	1.92	
90	3.10	5.00	6.89	8.79	10.69	12.59	14.48	16.38	18.28	20.18	22.07	
2.29	0.29	0.46	0.64	0.82	0.99	1.17	1.35	1.52	1.70	1.87	2.05	
96	3.30	5.32	7.34	9.37	11.39	13.41	15.43	17.45	19.47	21.49	23.51	
2.44	0.31	0.49	0.68	0.87	1.06	1.25	1.43	1.62	1.81	2.00	2.18	
102	3.57	5.76	7.94	10.13	12.32	14.50	16.69	18.87	21.06	23.25	25.43	
2.59	0.33	0.53	0.74	0.94	1.14	1.35	1.55	1.75	1.96	2.16	2.36	
108	3.77	6.08	8.39	10.70	13.01	15.32	17.63	19.94	22.25	24.56	26.87	
2.74	0.35	0.57	0.78	0.99	1.21	1.42	1.64	1.85	2.07	2.28	2.50	
114	3.98	6.41	8.84	11.28	13.71	16.14	18.58	21.01	23.45	25.88	28.31	
2.90	0.37	0.60	0.82	1.05	1.27	1.50	1.73	1.95	2.18	2.40	2.63	
120	4.18	6.73	9.29	11.85	14.41	16.96	19.52	22.08	24.64	27.19	29.75	
3.05	0.39	0.63	0.86	1.10	1.34	1.58	1.81	2.05	2.29	2.53	2.76	

<b>SCHEDULE TYPE:</b>	Page 2 of 3			
<b>PROJECT:</b>	Dimensions are in inches (mm).			
<b>ENGINEER:</b>	<b>DATE</b>	<b>B SERIES</b>	<b>SUPERSEDES</b>	<b>DRAWING NO.</b>
<b>CONTRACTOR:</b>	7 - 31 - 24	1600M	1 - 30 - 24	1605WDM



**EXTRUDED ALUMINUM STATIONARY LOUVER**  
**MIAMI-DADE QUALIFIED • FLORIDA PRODUCT APPROVED**  
**WIND-DRIVEN RAIN RESISTANT**  
**5" (127) DEEP • HORIZONTAL BLADE • PERFORMANCE DATA**  
**MODEL: 1605WDM**

**AIRFLOW/WATER PENETRATION DATA**  
**for 48" x 48" (1219 x 1219) Louver Size**

Free Area %		47%
Free Area sq. ft. (sq. m.)		7.59 (0.71)
I N T A K E	Free Area Velocity at Point of Beginning Water Penetration at .01 oz./sq. ft. (3 ml/sq. m) (15 min. test duration)	1250 fpm (381 m/min.)*
	Air Volume at 1250 fpm	9,488 cfm (4478 l/s)
	Free Area Velocity	
	Pressure Drop @ 1250 fpm	.36 in. w.g. (90 Pa)

**NOTE:** To minimize water penetration when sizing intake louvers, select a Free Area Velocity that is **below** the beginning point of water penetration.\*Maximum Free Area Velocity tested is 1250 fpm. Beginning point of water penetration for this model is above 1250 fpm.

**WIND DRIVEN RAIN PERFORMANCE**

Core Ventilation	0	110	195	279	396	499	585	700	783	884	981
Rate in fpm (m/s)	(0.0)	(0.56)	(0.99)	(1.42)	(2.01)	(2.53)	(2.97)	(3.56)	(3.98)	(4.49)	(4.98)
Free Area Ventilation	0	216	382	547	776	978	1147	1372	1535	1733	1923
Rate in fpm (m/s)	(0.0)	(1.10)	(1.94)	(2.78)	(3.94)	(4.97)	(5.83)	(6.97)	(7.80)	(8.80)	(9.77)
Effectiveness Ratio (%)	100	100	100	100	100	99.6	99.5	99	97.3	94	91.4
Penetration Class	A	A	A	A	A	A	A	A	B	C	C

Test was based on a 39.375" x 39.375" (1.0 m x 1.0 m) core area louver tested at a rainfall rate of 3" per hour (76 mm/hour) with a wind velocity of **29 mph (13 m/s)**.

DISCHARGE LOSS COEFFICIENT CLASS (INTAKE): 3. (Discharge Loss Coefficient Classification is as follows: 1=0.4 and above, 2=0.3 to 0.399, 3 = 0.2 to 0.299, 4 = 0.199 and below.)

Core Ventilation	0	91	198	298	410	487	593	686	785	887	992
Rate in fpm (m/s)	(0.0)	(0.46)	(1.01)	(1.51)	(2.08)	(2.47)	(3.01)	(3.48)	(3.99)	(4.51)	(5.04)
Free Area Ventilation	0	178	388	584	804	955	1162	1345	1539	1739	1944
Rate in fpm (m/s)	(0.0)	(0.90)	(1.97)	(2.97)	(4.08)	(4.85)	(5.90)	(6.83)	(7.82)	(8.94)	(9.88)
Effectiveness Ratio (%)	100	99.6	99.3	99.2	98.6	98.1	97.7	96.4	93.4	89.8	85.5
Penetration Class	A	A	A	A	B	B	B	B	C	C	C

Test was based on a 39.375" x 39.375" (1.0 m x 1.0 m) core area louver tested at a rainfall rate of 8" per hour (203 mm/hour) with a wind velocity of **50 mph (22 m/s)**.

DISCHARGE LOSS COEFFICIENT CLASS (INTAKE): 3. (Discharge Loss Coefficient Classification is as follows: 1=0.4 and above, 2=0.3 to 0.399, 3 = 0.2 to 0.299, 4 = 0.199 and below.)



Nailor Industries Inc. certifies that the Model 1605WDM shown herein is licensed to bear the AMCA Certified Ratings Program seal. The ratings shown are based on tests and procedures performed in accordance with AMCA Publication 511 and comply with the requirements of the AMCA Certified Ratings Program. The AMCA Certified Ratings Program seal applies to Water Penetration, Wind Driven Rain, and Air Performance ratings.

Louvers were tested in accordance with AMCA Standard 500-L.



**PRESSURE DROP**

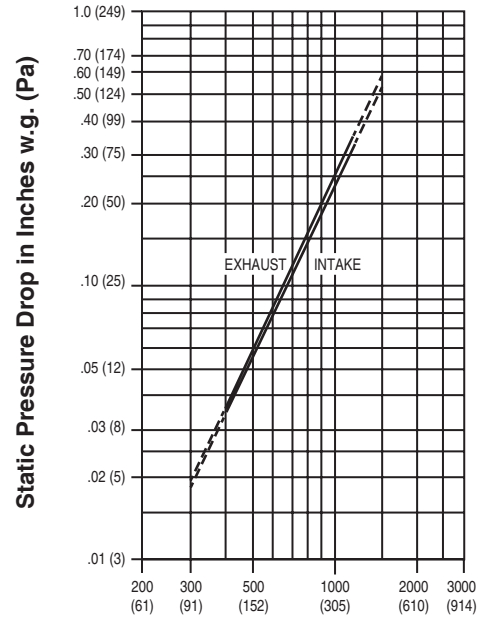

**Air Velocity in Feet (Meters) Per Minute Through Free Area**

Louver test size: 48" x 48" (1219 x 1219 mm).  
 Standard air density @ 0.075 lbs/ft³.  
 Tested to AMCA Fig. 5.5 – 6.5.



Nailor Industries Inc. certifies that the 1605WDM louver shown herein is approved to bear the AMCA International Listing Label. The ratings shown are based on tests and procedures performed in accordance with AMCA publications and comply with the requirements of the AMCA International Listing Label program. The AMCA International Listing Label applies to pressure cycle tested wind-borne debris impact resistant louvers rated for Enhanced Protection and +/- 150PSF with a minimum blade span of less than 12 in. (305mm) and a maximum unsupported blade span of 34 in. (864mm). The AMCA International Listing Label applies to High Velocity Wind-Driven Rain Resistant Louvers tested in the fully closed position that stops airflow through a louver.

<b>SCHEDULE TYPE:</b>				
<b>PROJECT:</b>				
<b>ENGINEER:</b>	<b>DATE</b>	<b>B SERIES</b>	<b>SUPERSEDES</b>	<b>DRAWING NO.</b>
<b>CONTRACTOR:</b>	7 - 31 - 24	1600M	1 - 30 - 24	1605WDM