

**QUALIFICATIONS:**

- Florida Product Approval No. : 19273.3
- Intertek Listed Building Product: Exterior Louvers.
- Tested in accordance with: TAS-201 (Large Missile Impact Test), TAS-202 (Uniform Static Air Pressure Test), TAS-203 (Cyclic Wind Pressure Loading Test).
- AMCA 500-L (Wind-Driven Rain, Water Penetration, Airflow).
- AMCA 540 (Wind-Borne Debris Impact Test [Enhanced "Level E" Protection]).
- AMCA 550 (High Velocity Wind-Driven Rain Resistance Test [with optional Model 2020 damper in closed position]).
- Wind load rating +/- 50 PSF (standard) (up to +/- 150 PSF dependent on size and configuration).

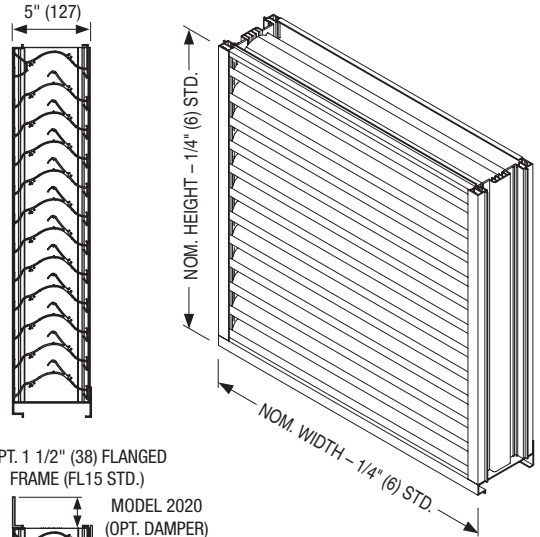

**STANDARD CONSTRUCTION:**

- FRAME:** 5" (127) deep, Type 6063-T6 extruded aluminum, .080" (2.03) nominal wall thickness. Integral downspouts and caulking slot provided.
- BLADES:** Type 6063-T6 extruded aluminum, .080" (2.03) nominal wall thickness, with reinforcing bosses.
- BLADE ANGLE:** Fixed at 30 degrees.
- BLADE SPACING:** 1.86" (47) on centers.
- BLADE SUPPORT:** Concealed type, factory installed on rear of louver. Size varies based on design pressure, consult Nailor.
- SCREEN:** 5/8" x .050 (15.9 x 1.27) expanded, flattened aluminum bird screen in removable frame, inside (rear) mount (adds approx. 3/8" [10] to louver depth).
- FINISH:** Mill.
- MINIMUM SIZE:** 12" W x 12" H (305 x 305).
- MAX. SINGLE SECTION SIZE:** 108" W x 84" H (2743 x 2134) or 84" W x 120" H (2134 x 3048). 63 – 70 sq. ft. (5.9 – 6.5 m<sup>2</sup>). Larger louvers will require field assembly of smaller sections.

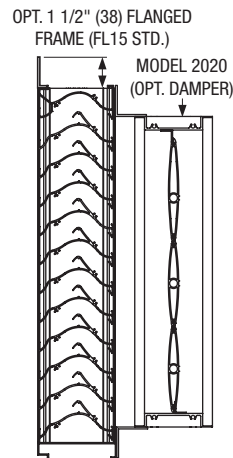

**OVERALL MAXIMUM SIZE:** Unlimited Width x 120" H (3048).

**OPTIONS:**

- |   |   |   |
|---|---|---|
| <input type="checkbox"/> <b>FL15</b> Flanged Frame, 1 1/2" (38).  | <input type="checkbox"/> <b>PC4</b> High Performance Powder Coat AAMA 2604 (Equivalent to 50% Kynar®). Color: _____ . | <input type="checkbox"/> <b>ANDB</b> Dark Bronze. |
| <input type="checkbox"/> <b>FL20</b> Flanged Frame, 2" (51).      | <input type="checkbox"/> <b>PC5</b> Fluoropolymer Powder Coat AAMA 2605 (Equivalent to 70% Kynar®). Color: _____ .    | <input type="checkbox"/> <b>ANBK</b> Black.       |
| <input type="checkbox"/> <b>BSSS</b> Type 304 S.S. Bird Screen.   | <input type="checkbox"/> <b>PCC</b> Prime Coat.   | <b>OPT. FACTORY MOUNTED 2020 CONTROL DAMPER:</b>  |
| <input type="checkbox"/> <b>BSN</b> No Bird Screen.               | <input type="checkbox"/> <b>AN04</b> Clear Anodized 204-R1.   | • Extruded Aluminum                               |
| <input type="checkbox"/> <b>ISA</b> Aluminum Insect Screen.       | <input type="checkbox"/> <b>AN15</b> Clear Anodized 215-R1.   | • Opposed Airfoil Blades                          |
| <input type="checkbox"/> <b>ISSS</b> Type 304 S.S. Insect Screen. | <input type="checkbox"/> <b>ANLB</b> Light Bronze.  | • Concealed Linkage                               |
| <input type="checkbox"/> <b>ESI</b> Extended Sill.                | <input type="checkbox"/> <b>ANMB</b> Medium Bronze.   | • Silicone Blade Seal                             |
| <input type="checkbox"/> <b>PASI</b> Sill Pan.                    |   | • Cambered Stainless Steel Jamb Seals             |
| <input type="checkbox"/> Other: _____ .                           |   | • 1/2" (13) Plated Steel Axles                    |

**OPTIONAL FINISHES:**

- PC3** Powder Coat AAMA 2603. Color: \_\_\_\_\_ .

For Installation Instructions, see IOM-LOUVERINSTFPA.

<b>SCHEDULE TYPE:</b>				
<b>PROJECT:</b>				
<b>ENGINEER:</b>	<b>DATE</b>	<b>B SERIES</b>	<b>SUPERSEDES</b>	<b>DRAWING NO.</b>
<b>CONTRACTOR:</b>	1 - 30- 24	1600F	10 - 31 - 18	1605WDF



**EXTRUDED ALUMINUM STATIONARY LOUVER**  
**FLORIDA PRODUCT APPROVED**  
 WIND-DRIVEN RAIN RESISTANT • 5" (127) DEEP  
 HORIZONTAL BLADE • PERFORMANCE DATA  
**MODEL: 1605WDF**



**FREE AREA in Square Feet and Square Meters**

		Width in Inches and Meters																
		12 0.30	18 0.46	24 0.61	30 0.76	36 0.91	42 1.07	48 1.22	54 1.37	60 1.52	66 1.68	72 1.83	78 1.98	84 2.13	90 2.29	96 2.44	102 2.59	108 2.74
Height in Inches and Meters	12 0.30	0.27 0.03	0.43 0.04	0.60 0.06	0.76 0.07	0.93 0.09	1.09 0.10	1.26 0.12	1.42 0.13	1.59 0.15	1.75 0.16	1.92 0.18	2.08 0.19	2.25 0.21	2.41 0.22	2.58 0.24	2.74 0.25	2.91 0.27
	18 0.46	0.47 0.04	0.76 0.07	1.05 0.10	1.34 0.12	1.63 0.15	1.92 0.18	2.20 0.20	2.49 0.23	2.78 0.26	3.07 0.29	3.36 0.31	3.65 0.34	3.94 0.37	4.23 0.39	4.51 0.42	4.80 0.45	5.09 0.47
	24 0.61	0.74 0.07	1.19 0.11	1.65 0.15	2.10 0.20	2.56 0.24	3.01 0.28	3.46 0.32	3.92 0.36	4.37 0.41	4.82 0.45	5.28 0.49	5.73 0.53	6.19 0.57	6.64 0.62	7.09 0.66	7.55 0.70	8.00 0.74
	30 0.76	0.94 0.09	1.52 0.14	2.10 0.19	2.68 0.25	3.25 0.30	3.83 0.36	4.41 0.41	4.99 0.46	5.56 0.52	6.14 0.57	6.72 0.62	7.30 0.68	7.87 0.73	8.45 0.79	9.03 0.84	9.61 0.89	10.18 0.95
	36 0.36	1.15 0.11	1.85 0.17	2.55 0.24	3.25 0.30	3.95 0.37	4.65 0.43	5.35 0.50	6.05 0.56	6.76 0.63	7.46 0.69	8.16 0.76	8.86 0.82	9.56 0.89	10.26 0.95	10.96 1.02	11.66 1.08	12.37 1.15
	42 1.07	1.35 0.13	2.17 0.20	3.00 0.28	3.82 0.36	4.65 0.43	5.47 0.51	6.30 0.59	7.12 0.66	7.95 0.74	8.77 0.81	9.60 0.89	10.42 0.97	11.25 1.04	12.07 1.12	12.90 1.20	13.72 1.27	14.55 1.35
	48 1.22	1.62 0.15	2.61 0.24	3.60 0.33	4.59 0.43	5.58 0.52	6.57 0.61	7.59 0.71	8.55 0.79	9.54 0.89	10.53 0.98	11.52 1.07	12.51 1.16	13.5 1.25	14.49 1.35	15.48 1.44	16.47 1.53	17.46 1.62
	54 1.37	1.82 0.17	2.93 0.27	4.05 0.38	5.16 0.48	6.27 0.58	7.39 0.69	8.50 0.79	9.62 0.89	10.73 1.00	11.84 1.10	12.96 1.20	14.07 1.31	15.18 1.41	16.30 1.51	17.41 1.62	18.53 1.72	19.64 1.82
	60 1.52	2.02 0.19	3.26 0.30	4.50 0.42	5.73 0.53	6.97 0.65	8.21 0.76	9.45 0.88	10.68 0.99	11.92 1.11	13.16 1.22	14.40 1.34	15.63 1.45	16.87 1.57	18.11 1.68	19.35 1.80	20.58 1.91	21.82 2.03
	66 1.68	2.22 0.21	3.58 0.33	4.95 0.46	6.31 0.59	7.67 0.71	9.03 0.84	10.39 0.97	11.75 1.09	13.11 1.22	14.47 1.34	15.84 1.47	17.2 1.60	18.56 1.72	19.92 1.85	21.28 1.98	22.64 2.10	24.00 2.23
	72 1.83	2.49 0.23	4.02 0.37	5.55 0.52	7.07 0.66	8.60 0.80	10.12 0.94	11.65 1.08	13.18 1.22	14.70 1.37	16.23 1.51	17.76 1.65	19.28 1.79	20.81 1.93	22.33 2.07	23.86 2.22	25.39 2.36	26.91 2.50
	78 1.98	2.7 0.25	4.35 0.40	6.00 0.56	7.65 0.71	9.30 0.86	10.95 1.02	12.6 1.17	14.25 1.32	15.90 1.48	17.55 1.63	19.20 1.78	20.85 1.94	22.5 2.09	24.15 2.24	25.80 2.40	27.45 2.55	29.10 2.70
	84 2.13	2.9 0.27	4.67 0.43	6.44 0.60	8.22 0.76	9.99 0.93	11.77 1.09	13.54 1.26	15.31 1.42	17.09 1.59	18.86 1.75	20.63 1.92	22.41 2.08	24.18 2.25	25.96 2.41	27.73 2.58	29.5 2.74	31.28 2.91
	90 2.29	3.10 0.29	5.00 0.46	6.89 0.64	8.79 0.82	10.69 0.99	12.59 1.17	14.48 1.35	16.38 1.52	18.28 1.70	20.18 1.87	22.07 2.05	23.97 2.23	25.87 2.40	27.77 2.57	29.67 2.74	31.57 2.91	33.47 3.08
	96 2.44	3.30 0.31	5.32 0.49	7.34 0.68	9.37 0.87	11.39 1.06	13.41 1.25	15.43 1.43	17.45 1.62	19.47 1.81	21.49 2.00	23.51 2.18	25.54 2.37	27.56 2.56	29.58 2.75	31.60 2.93	33.62 3.15	35.64 3.33
	102 2.59	3.57 0.33	5.76 0.53	7.94 0.74	10.13 0.94	12.32 1.14	14.50 1.35	16.69 1.55	18.87 1.75	21.06 1.96	23.25 2.16	25.43 2.36	27.62 2.57	29.81 2.77	32.00 2.97	34.19 3.17	36.38 3.37	38.57 3.57
	108 2.74	3.77 0.35	6.08 0.57	8.39 0.78	10.70 0.99	13.01 1.21	15.32 1.42	17.63 1.64	19.94 1.85	22.25 2.07	24.56 2.28	26.87 2.50	29.18 2.71	31.49 2.93	33.80 3.18	36.11 3.39	38.42 3.58	40.73 3.77
	114 2.90	3.98 0.37	6.41 0.60	8.84 0.82	11.28 1.05	13.71 1.27	16.14 1.50	18.58 1.73	21.01 1.95	23.45 2.18	25.88 2.40	28.31 2.63	30.75 2.86	33.18 3.08	35.61 3.30	38.04 3.50	40.47 3.70	42.90 3.90
	120 3.05	4.18 0.39	6.73 0.63	9.29 0.86	11.85 1.10	14.41 1.34	16.96 1.58	19.52 1.81	22.08 2.05	24.64 2.29	27.19 2.53	29.75 2.76	32.31 3.00	34.87 3.24	37.43 3.44	40.00 3.64	42.57 3.84	45.14 4.04

<b>SCHEDULE TYPE:</b>		Page 2 of 3			
<b>PROJECT:</b>		Dimensions are in inches (mm).			
<b>ENGINEER:</b>	<b>DATE</b>	<b>B SERIES</b>	<b>SUPERSEDES</b>	<b>DRAWING NO.</b>	
<b>CONTRACTOR:</b>	1 - 30 - 24	1600F	10 - 31 - 18	1605WDF	



**EXTRUDED ALUMINUM STATIONARY LOUVER**  
**FLORIDA PRODUCT APPROVED**  
 WIND-DRIVEN RAIN RESISTANT • 5" (127) DEEP  
 HORIZONTAL BLADE • PERFORMANCE DATA  
**MODEL: 1605WDF**



**AIRFLOW/WATER PENETRATION DATA**  
**for 48" x 48" (1219 x 1219) Louver Size**

Free Area %		47%
Free Area sq. ft. (sq. m.)		7.59 (0.71)
INTAKE	Free Area Velocity at Point of Beginning Water Penetration at .01 oz./sq. ft. (3 ml/sq. m) (15 min. test duration)	1250 fpm (381 m/min.)*
	Air Volume at 1250 fpm	9,488 cfm (4477 l/s)
	Free Area Velocity	
	Pressure Drop @ 1000 fpm	.22 in. w.g. (55 Pa)

**NOTE:** To minimize water penetration when sizing intake louvers, select a Free Area Velocity that is **below** the beginning point of water penetration.\*Maximum Free Area Velocity tested is 1250 fpm. Beginning point of water penetration for this model is above 1250 fpm.

**WIND DRIVEN RAIN PERFORMANCE**

Core Ventilation	0	110	195	279	396	499	585	700	783	884	981
Rate in fpm (m/s)	(0.0)	(0.56)	(0.99)	(1.42)	(2.01)	(2.53)	(2.97)	(3.56)	(3.98)	(4.49)	(4.98)
Free Area Ventilation	0	216	382	547	776	978	1147	1372	1535	1733	1923
Rate in fpm (m/s)	(0.0)	(1.10)	(1.94)	(2.78)	(3.94)	(4.97)	(5.83)	(6.97)	(7.80)	(8.80)	(9.77)
Effectiveness Ratio (%)	100	100	100	100	100	99.6	99.5	99	97.3	94	91.4
Penetration Class	A	A	A	A	A	A	A	A	B	C	C

Test was based on a 39.375" x 39.375" (1.0 m x 1.0 m) core area louver tested at a rainfall rate of 3" per hour (76 mm/hour) with a wind velocity of **29 mph (13 m/s)**.

DISCHARGE LOSS COEFFICIENT CLASS (INTAKE): 3. (Discharge Loss Coefficient Classification is as follows: 1=0.4 and above, 2=0.3 to 0.399, 3 = 0.2 to 0.299, 4 = 0.199 and below.)

Core Ventilation	0	91	198	298	410	487	593	686	785	887	992
Rate in fpm (m/s)	(0.0)	(0.46)	(1.01)	(1.51)	(2.08)	(2.47)	(3.01)	(3.48)	(3.99)	(4.51)	(5.04)
Free Area Ventilation	0	178	388	584	804	955	1162	1345	1539	1739	1944
Rate in fpm (m/s)	(0.0)	(0.90)	(1.97)	(2.97)	(4.08)	(4.85)	(5.90)	(6.83)	(7.82)	(8.94)	(9.88)
Effectiveness Ratio (%)	100	99.6	99.3	99.2	98.6	98.1	97.7	96.4	93.4	89.8	85.5
Penetration Class	A	A	A	A	B	B	B	B	C	C	C

Test was based on a 39.375" x 39.375" (1.0 m x 1.0 m) core area louver tested at a rainfall rate of 8" per hour (203 mm/hour) with a wind velocity of **50 mph (22 m/s)**.

DISCHARGE LOSS COEFFICIENT CLASS (INTAKE): 3. (Discharge Loss Coefficient Classification is as follows: 1=0.4 and above, 2=0.3 to 0.399, 3 = 0.2 to 0.299, 4 = 0.199 and below.)

**PRESSURE DROP**

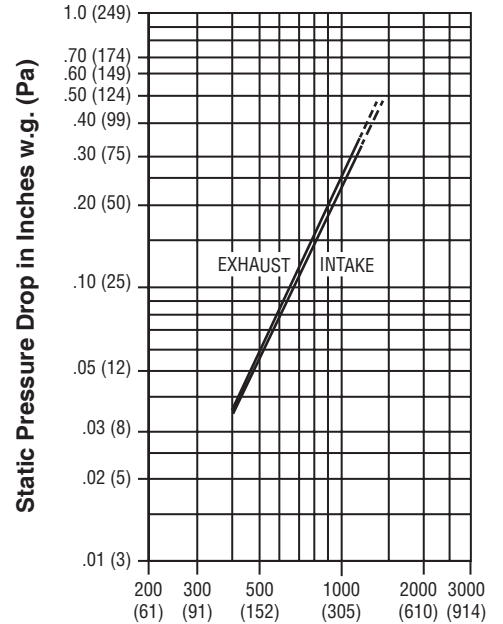

**Air Velocity in Feet (Meters) Per Minute Through Free Area**

Louver test size: 48" x 48" (1219 x 1219 mm).  
 Standard air density @ 0.075 lbs/ft<sup>3</sup>.  
 Tested to AMCA Fig. 5.5 – 6.5.



Nailor Industries Inc. certifies the Model 1605WDF shown herein is licensed to bear the AMCA Seal. The ratings shown are based on tests and procedures performed in accordance with AMCA Publication 511 and comply with the requirements of the AMCA Certified Ratings Program. Seal applies to air performance, water penetration and wind driven rain performance ratings.



Nailor Industries Inc. certifies that the 1605WDF shown herein is approved to bear the AMCA Listing Label. The ratings shown are based on tests and procedures performed in accordance with AMCA publications and comply with the requirements of the AMCA Listing Label Program. The AMCA Listing Label applies to Wind Borne Debris Impact Resistant Louvers. The AMCA Listing Label applies to High Velocity Wind Driven Rain Resistant Louvers.

<b>SCHEDULE TYPE:</b>	Page 3 of 3 Dimensions are in inches (mm).			
<b>PROJECT:</b>				
<b>ENGINEER:</b>	<b>DATE</b>	<b>B SERIES</b>	<b>SUPERSEDES</b>	<b>DRAWING NO.</b>
<b>CONTRACTOR:</b>	1 - 30 - 24	1600F	10 - 31 - 18	1605WDF