

MODEL AA1

Smoke Damper • Airfoil Blades • Leakage Class I • 250°F or 350°F Rated • Galvanized Steel

Standard Materials and Construction

- FRAME:** 5½" x 7⁄8" x 16 GA. galvanized steel hat channel. A flat head and sill are used for sizes up to 13" high.
- BLADES:** 20 GA. galvanized steel double skinned (equal to 14-GA), parallel action.
- AXLES:** Plated solid steel stub.
- BEARINGS:** Oil impregnated bronze.
- LINKAGE:** Plated steel angle and crank plates with stainless steel pivots, in-jamb type.
- STOPS:** 18 GA. galvanized steel at head and sill.
- BLADE SEALS:** Silicone.
- JAMB SEALS:** Stainless steel.
- SLEEVE:** Minimum 20 GA. galvanized steel by 18" long (sizes greater than 84" wide or 84" high require minimum 18 GA.).
- CAULKING:** Hardcast Irongrip 601 or UL-listed equivalent.
- FINISH:** Mill on galvanized steel.
- ACTUATOR:** Electric or pneumatic. Factory-installed for power-open/spring-close (fail close) operation, external left mount. Hand mounted as viewed from jackshaft side of damper.

UNDERWRITERS LABORATORIES INC.®
CLASSIFIED DYNAMIC SMOKE DAMPER
LEAKAGE RESISTANCE CLASS I



FILE # R19235



This smoke damper meets the construction and performance requirements of:

- Underwriters Laboratories Inc. Standards 555S
- National Fire Protection Association Standards 80 and 90A
- ICC's International Building Code
- New York City MEA Listing #112-99-M
- California State Fire Marshal Listing #3230-1328:111
- Underwriters Laboratories Inc. Approved for dual direction airflow and dynamic conditions.
- Underwriters Laboratories Inc. Classified for use in smoke control systems for Leakage Class I and 250°F or 350°F.
- Actuators must be controlled by a smoke detection system.

Options

- Exact Size (no undercut)
- Flange - Front, Rear or Both
- Actuators - 120V, 24V, 230V, Pneumatic
- Right Hand and/or Internal Actuator Mounting Locations (Restrictions Apply)
- Dual Position Indication (IDPI) Switches
- Model SM-501 Flow-Rated Smoke Detector
- Model 2151 No-Flow Smoke Detector (12" Minimum Damper Height)
- Remote Test Box
- Momentary Test Switch
- Transformers
- Tab-Lock Retaining Angles - 1 or 2 sets
- Stainless Steel Bearings
- Stainless Steel Axles
- Copper Tubing (pneumatic actuator)
- Sleeves of various depths and gauge thicknesses (restrictions apply)
- No sleeve or sideplate (restrictions apply)
- Round or oval transitions
- Security bars
- Short-width (less than 8") and/or Short-height (less than 6") transitions

Notes

1. Nominal deductions will be made to the opening size given.
2. Dampers greater than or equal to 12" in height with factory mounted SM-501 smoke detectors require a minimum 19" deep sleeve (10½" on the actuator side). Detectors will be mounted on the side of the damper opposite actuator.
3. Dampers less than 12" in height with factory mounted SM-501 smoke detectors require a minimum 20" deep sleeve (11½" on the actuator side). Detectors will be mounted on the bottom or top of damper.
4. Smoke detectors can be ordered for field mounting with standard 18" deep sleeve.
5. Dampers for horizontal installation can only be mounted in a fire barrier constructed of masonry/concrete materials.

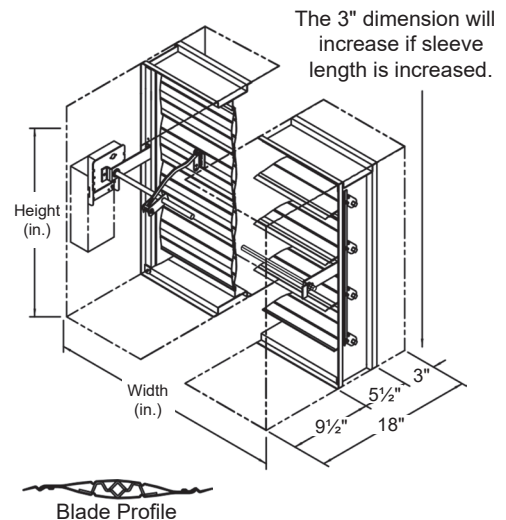

Item #	Qty	Damper Size	Horizontal	Vertical	250°F	350°F	Velocity	Pressure	Union Made
			Orientation		Temp. Rating		Operational Rating		
Arch. / Eng.:					EDR:		ECN:		Job:
Contractor:									
Project:					Date:		DWN:		DWG:



MODEL AA1

Smoke Damper • Airfoil Blades • Leakage Class I • 250°F or 350°F Rated • Galvanized Steel

Operational Rating

Maximum Differential Pressure: 4 in. w.g. (6 in. w.g. for selected size/actuator combinations)
 Maximum Velocity: 2000 fpm (4000 fpm for selected size/actuator combinations)

Leakage Rating

UL Class I

- 4 cfm per sq. ft. maximum @ 1 in. w.g.
- 8 cfm per sq. ft. maximum @ 4 in. w.g.
- 9.8 cfm per sq. ft. maximum @ 6 in. w.g.

Pressure Drop Rating

The pressure drop data shown below is based on laboratory conditions. The test setup does not take into account elbows or other duct fittings that are part of every actual duct system. The configuration of the actual duct system immediately upstream and downstream of the damper often contributes more pressure loss than the damper itself.

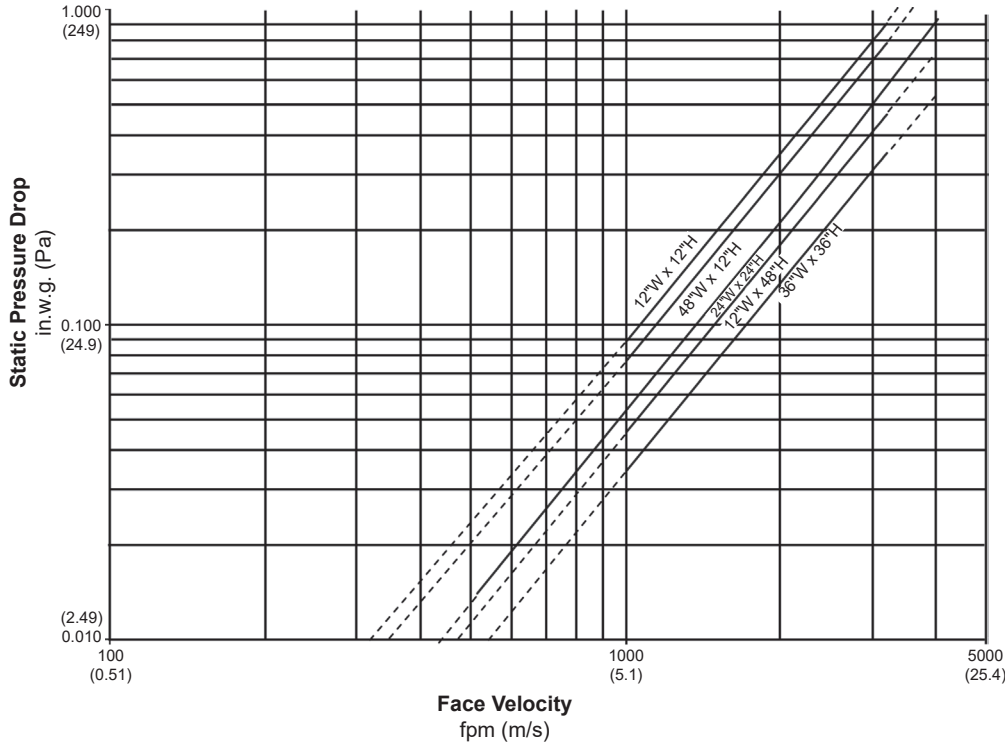

Tested in accordance with AMCA Standard 500D, Figure 5.3
 Intake air converted to standard air density.



Arrow United Industries certifies that the model AA1 damper shown here is licensed to bear the AMCA seal. The ratings shown are based on tests and procedures performed in accordance with AMCA Publication 511 and comply with the requirements of the AMCA Certified Ratings Program. The AMCA Certified Ratings Seal applies to Air Performance Ratings only.

MODEL AA1

Smoke Damper • Airfoil Blades • Leakage Class I • 250°F or 350°F Rated • Galvanized Steel

Sizing Chart

Damper Style	Temp Rating	Velocity & Pressure	Horizontal and Vertical Min Panel	Horizontal and Vertical Max Panel	Horizontal and Vertical Max Assembly
No Transition	250°F or 350°F	2000 FPM, 4 in. w.g.	8" x 6" frame	36" x 48" frame	144" x 96" frame -or- 288" x 48" frame
		3000 FPM, 4 in. w.g.		24" x 36" frame -or- 36" x 24" frame	96" x 72" frame
		4000 FPM, 4 in. w.g.			96" x 36" frame -or- 108" x 24" frame
	250°F	4000 FPM, 6 in. w.g.		16" x 24" frame -or- 24" x 20" frame	32"W x 24"H frame
	350°F	4000 FPM, 6 in. w.g. (external actuator only)		16" x 24" frame	
C-Round -or- C-Square	250°F or 350°F	2000 FPM, 4 in. w.g.	4" dia. duct -or- 4" x 4" duct (8" x 6" frame)	34" dia. duct -or- 34" x 34" duct	81" dia. duct -or- 81" x 81" duct
		3000 FPM, 4 in. w.g.		22" dia. duct -or- 22" x 22" duct	70" dia. duct -or- 70" x 70" duct
		4000 FPM, 4 in. w.g.			34" dia. -or- 34" x 34" duct
	250°F	4000 FPM, 6 in. w.g.		18" dia. duct -or- 18" x 18" duct	22" dia. duct -or- 22" x 22" duct
	350°F	4000 FPM, 6 in. w.g. (external actuator only)		14" dia. duct -or- 14" x 14" duct	
C-Oval -or- C-Rectangle	250°F or 350°F	2000 FPM, 4 in. w.g.	4" dia. duct (8" x 6" frame)	34" x 46" duct	70" x 94" duct -or- 94" x 70" duct
		3000 FPM, 4 in. w.g.		22" x 34" duct -or- 34" x 22" duct	94" x 70" duct
		4000 FPM, 4 in. w.g.			94" x 34" duct -or- 106" x 22" duct
	250°F	4000 FPM, 6 in. w.g.		14" x 22" duct -or- 22" x 18" duct	30" x 22" duct
	350°F	4000 FPM, 6 in. w.g. (external actuator only)		14" x 22" duct	

All dimensions are shown as width x height.

For dampers with no transition, the order size will equal frame size, which should equal duct size.

Unless notes, duct size will be the order size.

For dampers with transitions, the damper's frame size will equal the order width + 2 inches x the order height plus 2 inches.

When using a true 6" high damper, width is limited to 16". If damper is ordered as 6" high and width is less than 16", an 8" high damper with 2" short-height transition will be supplied.