

Combination Fire/Smoke Damper • 1½ Hr. Rated • Airfoil Blade • Leakage Class II • 250°F or 350°F Rated • Galvanized Steel

Standard Materials and Construction

- FRAME:** 5½" x 7⁄8" x 16 GA. galvanized steel hat channel. Flat head and sill for maximum free area on dampers less than or equal to 13" high.
- BLADES:** 20 GA. galvanized steel, double skinned (equal to 14 GA.), parallel action
- AXLES:** Plated solid steel stub.
- BEARINGS:** Oil impregnated bronze.
- LINKAGE:** Plated steel angle and crank plates with stainless steel pivots, in-jamb type.
- STOPS:** 18 GA. galvanized steel angles at head and sill
- BLADE SEALS:** Silicone.
- JAMB SEALS:** Stainless steel.
- SLEEVE:** Minimum 20 GA. galvanized steel by 18" long.
- CAULKING:** Hardcast Irongrip 601 or UL-listed equivalent.
- ACTUATOR:** Electric with heat response device (EHRD) or pneumatic with heat response device (PHRD). Factory-installed for power-open/spring-close (fail close) operation. External left hand mounted as viewed from jackshaft side of damper.
- FINISH:** Mill or galvanized steel.

Options

- Exact size (no undercut)
- Actuators - 120V, 24V, 230V or pneumatic
- Right hand and/or internal actuator mounting locations (restrictions apply)
- Dual Position Indication (DPI) switches
- Sensotherm Re-Openable Heat Response Device (ESOT) for electric actuators
- Sensotherm Re-Openable Heat Response Device (PSOT) for pneumatic actuators
- Model SM-501 flow-rated smoke detector
- Model 2151 no-flow smoke detector (12" minimum damper height)
- Momentary test switch
- Remote test box
- Transformers
- Tab-lock retaining angles
- Stainless steel bearings
- Stainless steel axles
- Security bars
- Copper tubing (for pneumatic actuators)
- Sleeves of various depths and gauge thicknesses (restriction apply)
- No sleeves (restriction apply)
- Round or oval transitions
- Short-width (less than 8") and/or short-height (less than 6") transitions

Notes

1. Nominal deductions will be made to the opening size given.
2. Dampers greater than or equal to 12" in height with factory mounted SM-501 smoke detectors require a minimum 19" deep sleeve (10½" on the actuator side). Detectors will be mounted on the side of the damper opposite actuator.
3. Dampers less than 12" in height with factory mounted SM-501 smoke detectors require a minimum 20 deep sleeve (11½" on the actuator side). Detectors will be mounted on the bottom or top of damper.
4. Smoke detectors can be ordered for field mounting with standard 18" deep sleeve.
5. Dampers for horizontal installation can only be mounted in a fire barrier constructed of masonry/concrete materials.

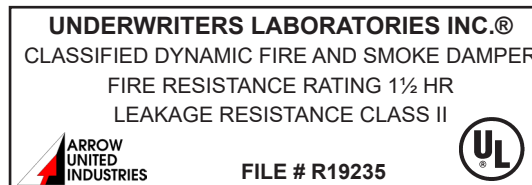

This combination fire/smoke damper meets the construction and performance requirements of:

- Underwriters Laboratories Inc. Standards 555 and 555S
- National Fire Protection Association Standards 80 and 90A
- ICC's International Building Code
- New York City MEA Listing #111-99-M
- California State Fire Marshal Listing #3225-1328:118
- Underwriters Laboratories Inc. Approved for dual direction airflow and dynamic conditions.
- Underwriters Laboratories Inc. Classified for use in fire resistive ratings of less than 3 hours.
- Underwriters Laboratories Inc. Classified for use in smoke control systems for Leakage Class II and 250°F or 350°F.
- Actuators must be arranged to operate automatically, must fail closed upon loss of power, and must be controlled by a smoke detection system.

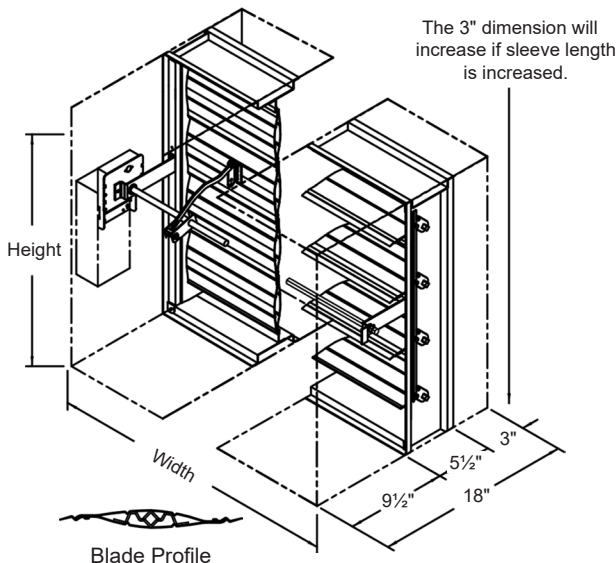

Damper Sizes

Orientation	Horz & Vert	** 2000 fpm, 4 in. w.g.				4000 fpm, 6 in. w.g.	
		Horizontal (floor)		Vertical (wall)		Horizontal & Vertical	
Panels	** Min Panel	Max Panel 250°F / 350°F	Max Assy 250°F / 350°F	Max Panel 250°F / 350°F	Max Assy 250°F / 350°F	Max Panel 250°F	Max Assy 250°F
Rectangular	4"W x 4"H (8"W x 6"H frame)	32"W x 48"H	96"W x 96"H	32"W x 48"H	128"W x 96"H	24"W x 24"H	96"W x 24"H
Round	4" dia. (8"W x 6"H frame)	30" dia.	81" dia.	30" dia.	81" dia.	22" dia.	-
Oval	4"W x 4"H (8"W x 6"H frame)	30"W x 46"H	45 sq. ft. 94"W x 94"H	30"W x 46"H	45 sq. ft. 106"W x 94"H	22"W x 22"H	45 sq. ft. 106"W x 94"H

*Dampers smaller than minimum frame size require a transition. Reference SD-TRFS.

** See sizing chart on page 3 for additional ratings.



Combination Fire/Smoke Damper • 1½ Hr. Rated • Airfoil Blade • Leakage Class II • 250°F or 350°F Rated • Galvanized Steel

Operational Ratings

Maximum Differential Pressure: 4 in. wg (6 in. wg for selected size/actuators combinations)
 Maximum Velocity: 2000 fpm (4000 fpm for selected size/actuator combinations)

Leakage Ratings

UL Leakage Class I
 10 cfm per sq. ft. maximum @ 1 in. wg
 20 cfm per sq. ft. maximum @ 4 in. wg
 24.5 cfm per sq. ft. maximum @ 6 in. wg

Pressure Drop Ratings

The Pressure drop data shown below is based on laboratory conditions. The test setup does not take into account elbows or other duct fittings that are part of every actual duct system. The configuration of the actual duct system immediately upstream and downstream of the damper often contributes more pressure loss than the damper itself.

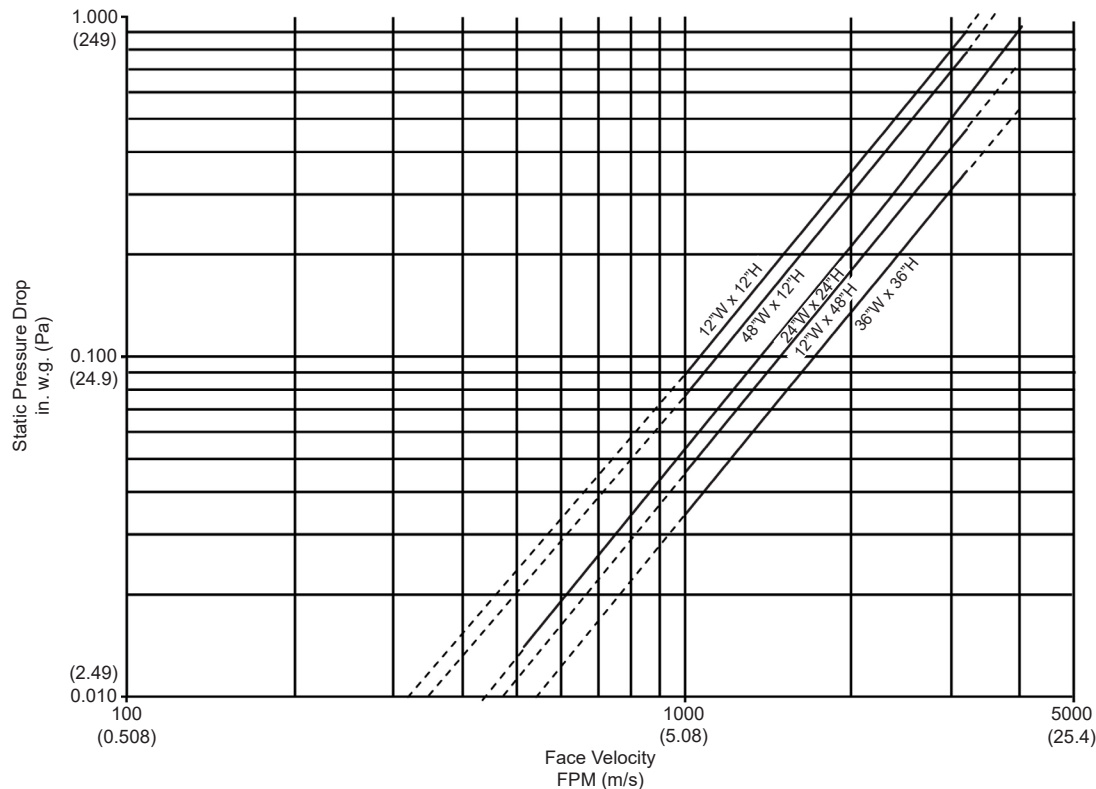

This product was tested in accordance with AMCA Standard 500D, Figure 5.3.

Intake air converted to standard air density.



Arrow United Industries certifies that the UA2 damper shown here is licensed to bear the AMA Seal. The ratings shown are based on tests and procedures performed in accordance with AMA Publication 511 and comply with the requirements of the AMCA Certified Ratings Program. The AMCA Certified Ratings Seal applies to the Air Performance Ratings only.

Item #	Qty	Damper Size	Horizontal	Vertical	250°F	350°F	Velocity	Pressure	
			Orientation		Temp. Rating		Operational Rating		
Arch. / Eng.:					EDR:		ECN:		Job:
Contractor:									
Project:					Date:		DWN:		DWG:



Sizing Chart

Damper Style	Temp. Rating (°F)	Velocity and Pressure	Minimum Panel (Horz & Vert)	Horizontal (Floor Mount)		Vertical (Wall Mount)	
				Max Panel	Max Assy	Max Panel	Max Assy
No Transition	250° or 350°	2000 FPM, 4in. w.g.	8"W x 6"H frame	32"W x 48"H frame	96"W x 96"H frame	32"W x 48"H frame	128"W x 96"H frame
		3000 FPM, 4in. w.g.		24"W x 36"H frame or 32"W x 24"H frame	96"W x 72"H frame or 96"W x 36"H frame	24"W x 36"H frame or 32"W x 24"H frame	96"W x 72"H frame or 96"W x 36"H frame
		4000 FPM, 4in. w.g.		24"W x 24"H frame	96"W x 24"H frame	24"W x 24"H frame	96"W x 24"H frame
	250°	4000 FPM, 6in. w.g.		16"W x 24"H frame	32"W x 24"H frame	16"W x 24"H frame	32"W x 24"H frame
	350°	4000 FPM, 6in. w.g. (external actuator)					
C-round or C-square	250° or 350°	2000 FPM, 4in. w.g.	4" dia. duct or 4"W x 4"H duct (8"W x 6"H frame)	30" dia. duct or 30"W x 30"H duct	81" dia. duct or 81"W x 81"H duct	30" dia. duct or 30"W x 30"H duct	81" dia. duct or 81"W x 81"H duct
		3000 FPM, 4in. w.g.		22" dia. duct or 22"W x 22"H duct	70" dia. duct or 70"W x 70"H duct or 34" dia. duct or 34"W x 34"H duct	22" dia. duct or 22"W x 22"H duct	70" dia. duct or 70"W x 70"H duct or 34" dia. duct or 34"W x 34"H duct
		4000 FPM, 4in. w.g.		22" dia. duct or 22"W x 22"H duct			
	250°	4000 FPM, 6in. w.g.		14" dia. duct or 14"W x 14"H duct	22" dia. duct or 22"W x 22"H duct	14" dia. duct or 14"W x 14"H duct	22" dia. duct or 22"W x 22"H duct
	350°	4000 FPM, 6in. w.g. (external actuator)					
C-oval or C-rectangle	250° or 350°	2000 FPM, 4in. w.g.	4"W x 4"H duct (8"W x 6"H frame)	30"W x 46"H duct	70"W x 94"H duct or 94"W x 70"H duct	30"W x 46"H duct	70"W x 94"H duct or 94"W x 70"H duct
		3000 FPM, 4in. w.g.		22"W x 34"H duct or 28"W x 22"H duct	94"W x 70"H duct or 94"W x 34"H duct	22"W x 34"H duct or 30"W x 22"H duct	94"W x 70"H duct or 94"W x 34"H duct
		4000 FPM, 4in. w.g.		22"W x 22"H duct	94"W x 22"H duct	22"W x 22"H duct	94"W x 22"H duct
	250°	4000 FPM, 6in. w.g.		14"W x 22"H duct	30"W x 22"H duct	14"W x 22"H duct	30"W x 22"H duct
	350°	4000 FPM, 6in. w.g. (external actuator)					

NOTES

- For dampers with no transition, the size to order will be frame size, which is equal to the size of the ductwork unless otherwise noted.
- For dampers with transition, the size to order will be as follows: width + 2" by height + 2"
- When the damper is 6" high, width is limited to 16". If the damper is ordered as 6" high and its width is less than 16", an 8" high damper with a 2" short-height transition will be supplied.