

Steel Control Damper • 5½" Deep • Airfoil Blade • 200°F Max Temperature • Parallel (517) or Opposed (518)

Standard Materials and Construction

- FRAME:** 5½" x 7/8" x 16 GA. galvanized steel hat channel.
- BLADE:** Airfoil shaped, double skin galvanized steel construction, 6% wide.
- LINKAGE:** Plated steel tie bar and crank plates with stainless steel pivots contained in jamb.
- AXLES:** ½" square plated steel.
- BEARINGS:** Heavy duty molded nylon.
- SEALS:** Vinyl on blades and stop angles, and stainless steel at jambs.
- FINISH:** Mill.
- TEMP. LIMIT:** -40 to 200°F

Options

- Exact Size
- Blade Action - Parallel (517) or Opposed (518)
- Material - 304 Stainless Steel
- Face/Bypass - Vertical, Horizontal or Perpendicular
- Sleeve - Transition - Sideplate
- Vertical Blades
- Flange - Front, Rear or Both
- Jackshaft (1/2" or 1" diameter, depending on damper size)
- Actuators - 120V, 24V, 230V or Pneumatic
- Accessories - manual quadrants, standoffs, extended shafts
- Position Indication - PK1200, PK1201 or integral to actuator Transformer
- Explosion Proof Housing
- Pilot Positioner (for pneumatic actuators)
- Copper Tubing (for pneumatic actuators)
- Tab-Lock Retaining Angles - 1 or 2 sets
- Bearings - OIL or Stainless Steel
- Axle - Stainless Steel
- Security Bars
- Finishes - Baked Enamel, Baked Epoxy or Prime Coat

Notes

1. Nominal deductions of ¼" made to the opening size (unless specified as exact size).
2. Depending upon damper height, a variable width blade may be required, which could extend to a maximum of 2⅝" from either face of the damper. Contact the factory if exact dimensions of this variable blade are critical.
3. Dampers less than 14" tall are flat head/sill construction to maximize free area.
4. Shipping weight is approximately 6.5 lbs/sqft

Damper Sizes

Panels	Min Panel	Max Single Panel
Parallel Blade	8"W x 6"H	48"W x 72"H
Opposed Blade	8"W x 12"H	48"W x 72"H

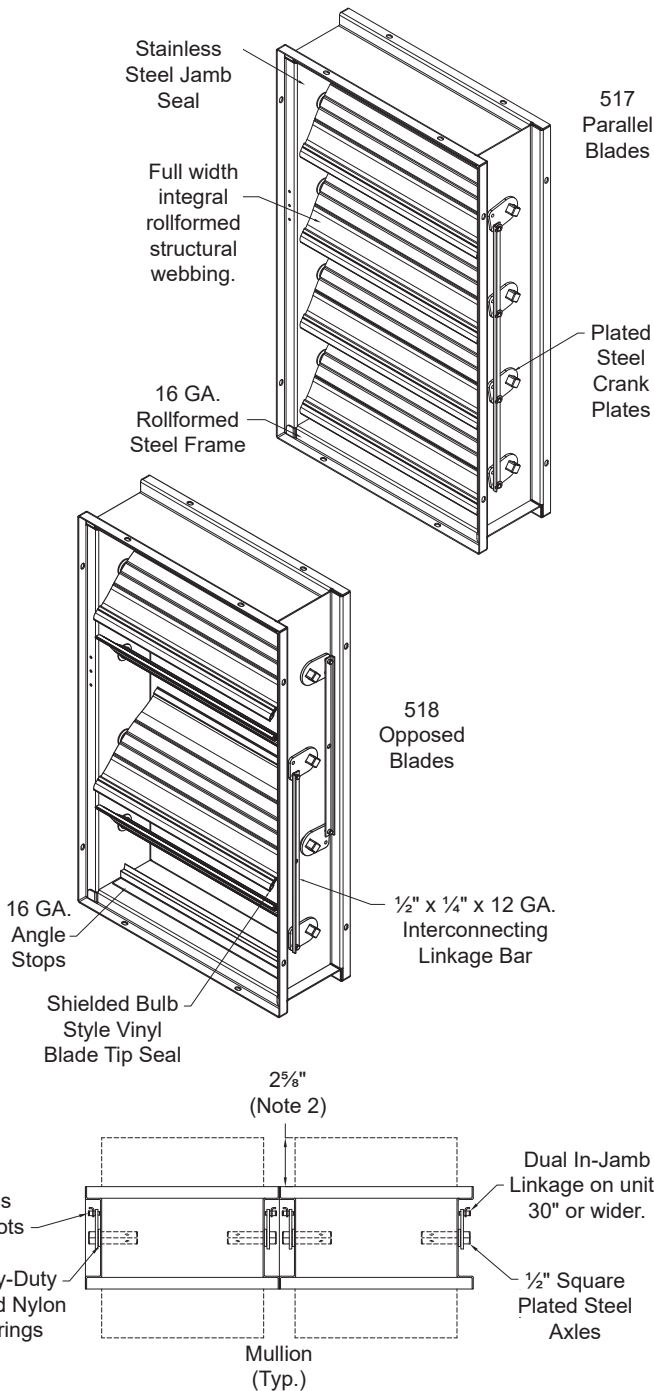

Item #	Qty	Width	Height	Parallel Blades	Opposed Blades	Seals	Actuator Model	Interior	Exterior	N.C.	N.O.	Union Made
								Act. Location		Function		
Arch. / Eng.:				EDR:		ECN:		Job:				
Contractor:				Date:		DWN:		DWG:				
Project:												



Steel Control Damper • 5½" Deep • Airfoil Blade • 200°F Max Temperature • Parallel (517) or Opposed (518)

Air Leakage

Air Leakage is based on operation between 32° F and 120° F. Tested for air leakage in accordance with ANSI/AMCA Standard 500-D, Figure 5.4. Data are based on a torque of 7 in-lb/ft² applied to close and seat the damper during the test. All data has been corrected to represent standard air density .075 lb/ft³.

Leakage Class Test Results

Parallel (517)

Damper Size	1 in. w.g.	4 in. w.g.	6 in. w.g.	8 in. w.g.	12 in. w.g.
12" W x 48" H	1A	1	1	1	1
36" W x 36" H	1A	1	1	1	1
48" W x 36" H	1A	1	1	1	-

Opposed (518)

Damper Size	1 in. w.g.	4 in. w.g.	6 in. w.g.	8 in. w.g.	12 in. w.g.
12" W x 48" H	1A	1	1	1	1
36" W x 36" H	1A	1	1	1	1
48" W x 36" H	1A	1	1	-	-

Air Performance

Tested for Air Performance in accordance with ANSI/AMCA Standard 500-D, Figure 5.3. Air performance testing was conducted using opposed blade dampers; the same results can be applied to parallel blade dampers. All data has been corrected to represent standard air density .075 lb/ft³.

Damper Size
12" x 12"

Velocity (fpm)	Δ P (in. w.g.)
500	0.01
1000	0.05
1500	0.11
2000	0.20
2500	0.31
3000	0.45
3500	0.61
4000	0.80
4500	1.01
5000	1.25

Damper Size
24" x 24"

Velocity (fpm)	Δ P (in. w.g.)
500	0.01
1000	0.03
1500	0.08
2000	0.14
2500	0.21
3000	0.31
3500	0.42
4000	0.55
4500	0.69
5000	0.85

Damper Size
12" x 48"

Velocity (fpm)	Δ P (in. w.g.)
500	0.01
1000	0.04
1500	0.08
2000	0.14
2500	0.22
3000	0.32
3500	0.43
4000	0.57
4500	0.72
5000	0.88

Damper Size
36" x 36"

Velocity (fpm)	Δ P (in. w.g.)
500	0.01
1000	0.02
1500	0.05
2000	0.09
2500	0.16
3000	0.20
3500	-
4000	-
4500	-
5000	-

Damper Size
48" x 12"

Velocity (fpm)	Δ P (in. w.g.)
500	0.01
1000	0.03
1500	0.08
2000	0.14
2500	0.21
3000	0.30
3500	0.41
4000	0.54
4500	0.68
5000	0.84

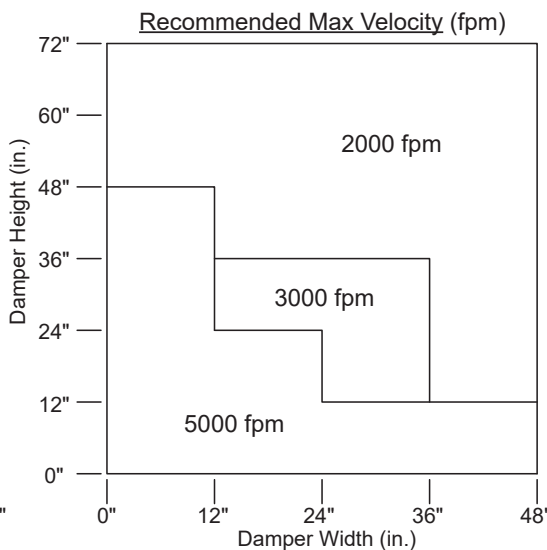
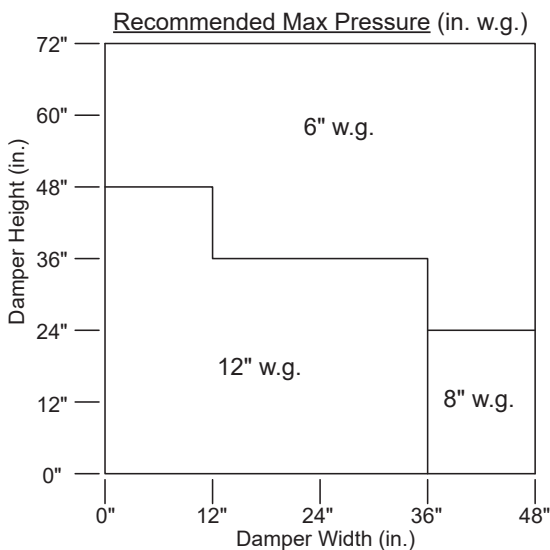

Arrow United Industries certifies that the Model 517-518 shown herein is licensed to bear the AMCA Seal. The ratings shown are based on tests and procedures performed in accordance with AMCA Publication 511 and comply with the requirements of the AMCA Certified Ratings Program. The AMCA Certified Ratings Seal applies to Air Leakage and Air Performance ratings only.