

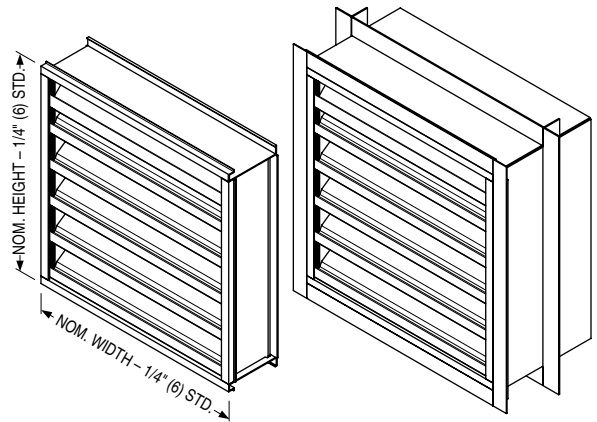

EXTRUDED ALUMINUM STATIONARY LOUVER
MIAMI-DADE QUALIFIED • FLORIDA PRODUCT APPROVAL PENDING
HIGH PERFORMANCE DRAINABLE BLADE
6" (152) DEEP • HORIZONTAL BLADE
MODEL: 1606DHPM

QUALIFICATIONS:

- Miami-Dade County NOA No. : 18-1217.02
- Florida Product Approval Pending.
- Tested in accordance with: TAS-100A (Wind-Driven Rain [with optional Model 2020 damper in closed position]), TAS-201 (Large Missile Impact Test), TAS-202 (Uniform Static Air Pressure Test) and TAS-203 (Cyclic Wind Pressure Loading Test).
- AMCA 500-L (Water Penetration, Airflow).
- AMCA 540 (Wind-Borne Debris Impact Test [Enhanced "Level E" Protection]).
- AMCA 550 (High Velocity Wind-Driven Rain Resistance Test [with optional Model 2020 damper in closed position]).
- Wind load rating +/- 150 PSF.



STANDARD CONSTRUCTION:

- FRAME:** 6" (152) deep, Type 6063-T6 extruded aluminum, .120" (3.05) nominal wall thickness. Integral downspouts and caulking slot provided.
- BLADES:** Type 6063-T6 extruded aluminum, .100" (2.54) nominal wall thickness, with reinforcing bosses.
- BLADE ANGLE:** Fixed at 37.5 degrees.
- BLADE SPACING:** Approximately 4" (102) on centers.
- BLADE SUPPORT:** Concealed type, factory installed on rear of louver. Reinforced with 2" x 2" (51 x 51) angle (adds approximately 2" [51] to overall louver depth).
- SCREEN:** 5/8" x .050 (15.9 x 1.27) expanded, flattened aluminum bird screen in removable frame, inside (rear) mount (adds approx. 3/8" [10] to louver depth).
- FINISH:** Mill.
- MINIMUM SIZE:** 12" W x 12" H (305 x 305).
- MAX. SINGLE SECTION SIZE:** 72" W x 120" H (1829 x 3048). 60 sq. ft. (5.6 m²) (36" W x 120" H [914 x 3048] with optional Model 2020 damper). Larger louvers will require field assembly of smaller sections.
- OVERALL MAX. SIZE:** Unlimited Width x 120" H (3048).

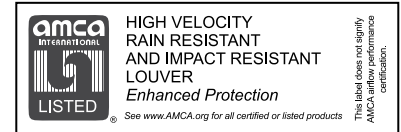
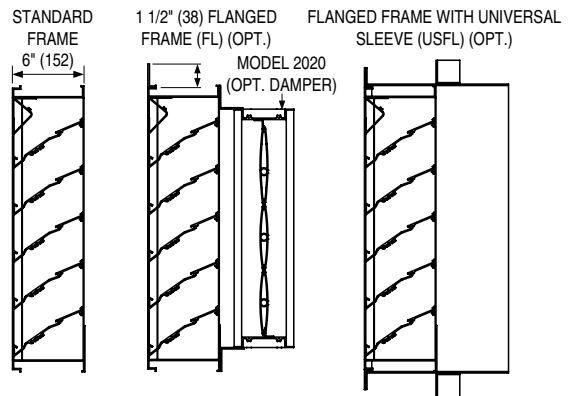

OPTIONS:

- BSSS** Type 304 S.S. Bird Screen.
- BSN** No Bird Screen.
- ISA** Aluminum Insect Screen.
- ISSS** Type 304 S.S. Insect Screen.
- FL** Flanged Frame.
- USFL** Universal Sleeve/Flanged Frame.
- ESI** Extended Sill.
- PASI** Sill Pan.
- Other: _____

OPTIONAL FINISHES:

- PC3** Powder Coat AAMA 2603. Color: _____
- PC4** High Performance Powder Coat AAMA 2604 (Equivalent to 50% Kynar®). Color: _____
- PC5** Fluoropolymer Powder Coat AAMA 2605 (Equivalent to 70% Kynar®). Color: _____
- PCC** Prime Coat.
- AN04** Clear Anodized 204-R1.
- AN15** Clear Anodized 215-R1.
- ANLB** Light Bronze.

- ANMB** Medium Bronze.
 - ANDB** Dark Bronze.
 - ANBK** Black.
- OPT. FACTORY MOUNTED 2020 CONTROL DAMPER:**
- Extruded Aluminum
 - Opposed Airfoil Blades
 - Concealed Linkage
 - Silicone Blade Seal
 - Cambered Stainless Steel Jamb Seals
 - 1/2" (13) Plated Steel Axles

SCHEDULE TYPE:	For Installation Instructions, see IOM-LOUVERINSTFPA.			
PROJECT:	Page 1 of 3 Dimensions are in inches (mm).			
ENGINEER:	DATE	B SERIES	SUPERSEDES	DRAWING NO.
CONTRACTOR:	4 - 9 - 19	1600M	NEW	1606DHPM



EXTRUDED ALUMINUM STATIONARY LOUVER
MIAMI-DADE QUALIFIED • FLORIDA PRODUCT APPROVAL PENDING
HIGH PERFORMANCE DRAINABLE BLADE
6" (152) DEEP • HORIZONTAL BLADE • PERFORMANCE DATA
MODEL: 1606DHPM

AIRFLOW/WATER PENETRATION DATA
for 48" x 48" (1219 x 1219) Louver Size

Free Area %		60%
Free Area sq. ft. (sq. m.)		9.65 (0.90)
I N T A K E	Free Area Velocity at Point of Beginning Water Penetration at .01 oz./sq. ft. (3 ml/sq. m) (15 min. test duration)	1164 fpm (361 m/min.)
	Air Volume at 1186 fpm Free Area Velocity	11,445 cfm (5401 l/s)
	Pressure Drop @ 1000 fpm	.15 in. w.g. (37 Pa)

NOTE: To minimize water penetration when sizing intake louvers, select a Free Area Velocity that is **below** the beginning point of water penetration.



Safe-Air Dowco certifies the Model 1606DHPM shown herein is licensed to bear the AMCA Seal. The ratings shown are based on tests and procedures performed in accordance with AMCA Publication 511 and comply with the requirements of the AMCA Certified Ratings Program. Seal applies to air performance ratings and water penetration ratings.



**HIGH VELOCITY
 RAIN RESISTANT
 AND IMPACT RESISTANT
 LOUVER**
Enhanced Protection

See www.AMCA.org for all certified or listed products

This label does not signify AMCA airflow performance certification.

Safe-Air Dowco certifies that the 1606DHPM shown herein is approved to bear the AMCA Listing Label. The ratings shown are based on tests and procedures performed in accordance with AMCA publications and comply with the requirements of the AMCA Listing Label Program. The AMCA Listing Label applies to Wind Borne Debris Impact Resistant Louvers. The AMCA Listing Label applies to High Velocity Wind Driven Rain Resistant Louvers.

PRESSURE DROP

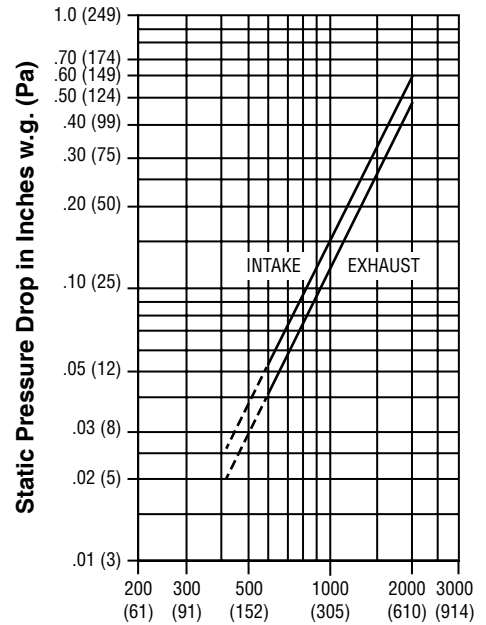

**Air Velocity in Feet (Meters) Per Minute
 Through Free Area**

Louver test size: 48" x 48" (1219 x 1219 mm).
 Standard air density @ 0.075 lbs/ft³.
 Tested to AMCA Fig. 5.5 – 6.5.

SCHEDULE TYPE:	Page 2 of 3			
PROJECT:	Dimensions are in inches (mm).			
ENGINEER:	DATE	B SERIES	SUPERSEDES	DRAWING NO.
CONTRACTOR:	4 - 9 - 19	1600M	NEW	1606DHPM



EXTRUDED ALUMINUM STATIONARY LOUVER
MIAMI-DADE QUALIFIED • FLORIDA PRODUCT APPROVAL PENDING
HIGH PERFORMANCE DRAINABLE BLADE
6" (152) DEEP • HORIZONTAL BLADE • PERFORMANCE DATA
MODEL: 1606DHPM

FREE AREA in Square Feet and Square Meters

		Width in Inches and Meters										
		12 0.30	18 0.46	24 0.61	30 0.76	36 0.91	42 1.07	48 1.22	54 1.37	60 1.52	66 1.68	72 1.83
Height in Inches and Meters	12 0.30	0.31 0.03	0.51 0.05	0.70 0.07	0.89 0.08	1.09 0.10	1.28 0.12	1.48 0.14	1.67 0.16	1.87 0.17	2.06 0.19	2.25 0.21
	18 0.46	0.60 0.06	0.98 0.09	1.35 0.13	1.73 0.16	2.11 0.20	2.48 0.23	2.86 0.27	3.23 0.30	3.61 0.34	3.99 0.37	4.36 0.41
	24 0.61	0.90 0.08	1.47 0.14	2.03 0.19	2.60 0.24	3.16 0.29	3.73 0.35	4.29 0.40	4.85 0.45	5.42 0.50	5.98 0.56	6.55 0.61
	30 0.76	1.19 0.11	1.93 0.18	2.68 0.25	3.42 0.32	4.16 0.39	4.90 0.46	5.64 0.52	6.39 0.59	7.13 0.66	7.87 0.73	8.61 0.80
	36 0.36	1.33 0.12	2.16 0.20	3.00 0.28	3.83 0.36	4.66 0.43	5.49 0.51	6.32 0.59	7.15 0.66	7.98 0.74	8.81 0.82	9.65 0.90
	42 1.07	1.77 0.16	2.87 0.27	3.97 0.37	5.07 0.47	6.17 0.57	7.27 0.68	8.37 0.78	9.47 0.88	10.57 0.98	11.67 1.08	12.78 1.19
	48 1.22	2.05 0.19	3.33 0.31	4.61 0.43	5.89 0.55	7.17 0.67	8.45 0.79	9.65 0.90	11.01 1.02	12.29 1.14	13.57 1.26	14.85 1.38
	54 1.37	2.34 0.22	3.80 0.35	5.26 0.49	6.73 0.62	8.19 0.76	9.65 0.90	11.11 1.03	12.57 1.17	14.03 1.30	15.49 1.44	16.95 1.57
	60 1.52	2.64 0.24	4.28 0.40	5.92 0.55	7.57 0.70	9.21 0.86	10.86 1.01	12.50 1.16	14.14 1.31	15.79 1.47	17.43 1.62	19.07 1.77
	66 1.68	2.92 0.27	4.74 0.44	6.56 0.61	8.39 0.78	10.21 0.95	12.03 1.12	13.85 1.29	15.67 1.46	17.49 1.63	19.31 1.79	21.13 1.96
	72 1.83	3.21 0.30	5.22 0.48	7.22 0.67	9.22 0.86	11.23 1.04	13.23 1.23	15.24 1.42	17.24 1.60	19.24 1.79	21.25 1.97	23.25 2.16
	78 1.98	3.50 0.33	5.68 0.53	7.87 0.73	10.05 0.93	12.23 1.14	14.41 1.34	16.60 1.54	18.78 1.74	20.96 1.95	23.14 2.15	25.33 2.35
	84 2.13	3.79 0.35	6.16 0.57	8.52 0.79	10.89 1.01	13.25 1.23	15.61 1.45	17.98 1.67	20.34 1.89	22.71 2.11	25.07 2.33	27.43 2.55
	90 2.29	4.08 0.38	6.63 0.62	9.17 0.85	11.72 1.09	14.26 1.32	16.81 1.56	19.35 1.80	21.89 2.03	24.44 2.27	26.98 2.51	29.53 2.74
	96 2.44	4.37 0.41	7.09 0.66	9.82 0.91	12.54 1.17	15.27 1.42	17.99 1.67	20.71 1.92	23.44 2.18	26.16 2.43	28.89 2.68	31.61 2.94
	102 2.59	4.66 0.43	7.57 0.70	10.47 0.97	13.38 1.24	16.28 1.51	19.19 1.78	22.09 2.05	25.00 2.32	27.90 2.59	30.81 2.86	33.71 3.13
108 2.74	4.95 0.46	8.04 0.75	11.12 1.03	14.21 1.32	17.29 1.61	20.38 1.89	23.46 2.18	26.55 2.47	29.63 2.75	32.72 3.04	35.80 3.33	
114 2.90	5.24 0.49	8.51 0.79	11.78 1.09	15.04 1.40	18.31 1.70	21.58 2.00	24.84 2.31	28.11 2.61	31.38 2.92	34.65 3.22	37.91 3.52	
120 3.05	5.53 0.51	8.98 0.83	12.42 1.15	15.87 1.47	19.31 1.79	22.76 2.11	26.21 2.43	29.65 2.75	33.10 3.07	36.54 3.40	39.99 3.72	

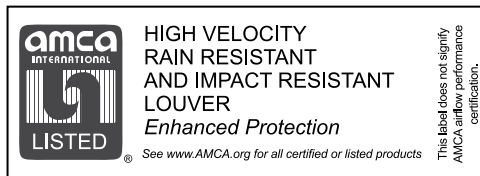

This label does not signify AMCA airflow performance certification.

SCHEDULE TYPE:	Page 3 of 3			
PROJECT:	Dimensions are in inches (mm).			
ENGINEER:	DATE	B SERIES	SUPERSEDES	DRAWING NO.
CONTRACTOR:	4 - 9 - 19	1600M	NEW	1606DHPM