



KRUGER

BNC

PLENUM FAN

with Backward Curved Wheels



BNC Series

PLENUM FAN with Backward Curved Wheels



Kruger* Ventilation Industries Asia Co., Ltd. certifies that the BNC Series shown herein is licensed to bear the AMCA Seal. The ratings shown are based on tests and procedures performed in accordance with AMCA Publication 211 and AMCA Publication 311 and comply with the requirements of the AMCA Certified Ratings Program.



*Kruger Ventilation Industries Asia Co., Ltd.



*Kruger Ventilation Industries (India) Pvt. Ltd.



*Kruvent Industries (M) Sdn Bhd



*Kruger Ventilation (Taiwan) Co., Ltd.

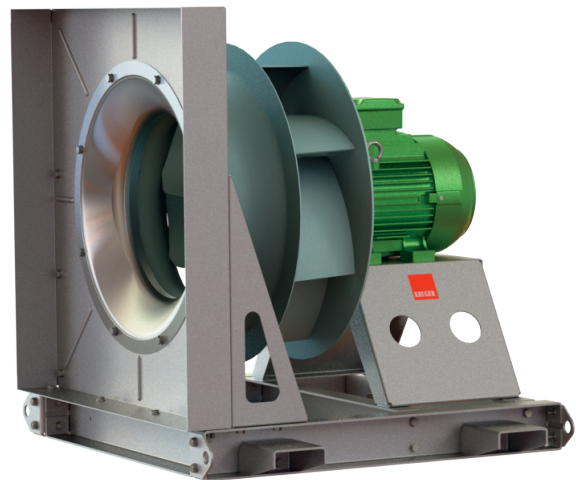
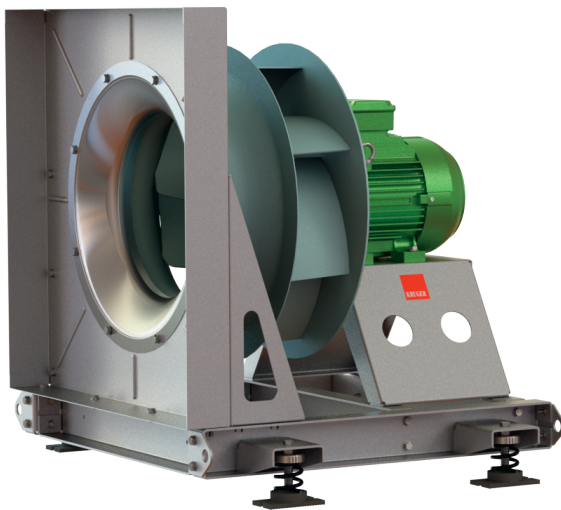

BNC Series

Plenum Fans – Backward curved wheels

Kruger Plenum Fans are designed for air handling application where the fan wheel operates without housing, inside a plenum. This results in saving of space normally occupied by the fan housing, transition and diffusers. The fan wheel pressurizes the entire plenum in which the fan is installed. This allows air ducts to be directly connected from any direction to the plenum. The compact size of the plenum fan makes it an excellent selection for retrofit and replacement application and for variable air volume systems.

There are three types of BNC Series, i.e. BNC-R (regular type), BNC-P (high pressure ratio type), BNC-Q (high volume ratio type).

NOMENCLATURE

MODEL: BNC-R 450 / D I

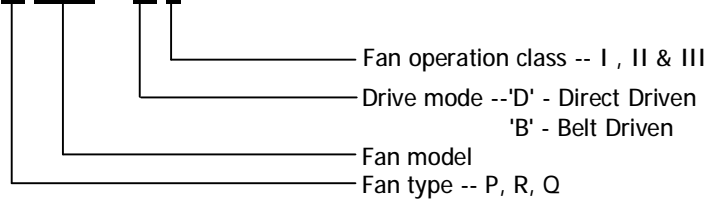

TYPE / OPERATING LIMIT

Each fan type has its maximum operating speed and power due to its mechanical design.

The operating limit of BNC series is set according to the requirement of class I, II and III limit as defined in AMCA standard 99.

The BNC series is available in Direct Driven and Belt Driven, Type D, B as follow:

ECOWATT BNC Series-Direct Drive

This direct drive Ecowatt BNC series comes with a Kruger Ecowatt permanent magnet motor and a Kruger Ecowatt drive with Kruger Ecowatt demand-controlled ventilation system. This construction is mainly for users who desire to have high energy saving with fluctuating demands particularly long over operating hours.

Kruger Ecowatt Motor

- 3-phase TEFC Squirrel Cage Premium Efficiency Permanent Magnet Motor with IE4/IE5 efficiency.
- Design Standards BS 4999, BS 5000, IEC 60034, IEC 60072
- 380-415 Hz/50Hz \pm 10% of rated voltage
- Stator Insulation; Class F Insulation; Class B Temperature Rise
- Horizontal foot mounting or flange mounting: B3; B5, B14, B34; B35; V1
- Environmental Conditions: Standard Ambient Temperature: -20°C to 40°C; RH: <90% RH (non-condensation); Altitude < 1000m above sea level.



Kruger Ecowatt Drive

- High Performance with advanced vector control technology.
- Energy saving by PID function for Demand Controlled Ventilation.
- Easy control by Analog signal 0-10V, 4-20mA and RS485 Modbus RTU.
- Various drives both AC induction motor and Permanent magnet synchronous motor.
- IP54 protection rating, independent duct design (IP20 also available).
- Safety by STO (Safe Torque OFF) and fire overdrive function.
- Wide range of power 2.2kW – 220kW.



Kruger Ecowatt Demand Controlled Ventilation

- Automatic close loop PID control by TDP-PI Ventilation controller
 - Constant Airflow control
 - Constant Differential pressure control



Controller will maintain Pressure or Airflow as setting value by change fan speed up-down automatically follow actual load demand.

- Manual speed control by REB-Ecowatt
 - Adjust Fan speed by your hand with potentiometer 10kohm



Why Choose an Ecowatt System

- Highly efficient backward curved with FEG rating from 85-90 with direct coupling reduces frictional losses and optimizes transmission and improves energy costs.
- The energy that the electric motor generates is transmitted directly to the impeller, which passes into airflow and pressure development increases the overall fan system efficiency.
- In addition, zero belt wears and break on belt improves reliability and productive run time and unnecessary maintenance.
- Save energy cost up to 78% when driven by Kruger Ecowatt system.

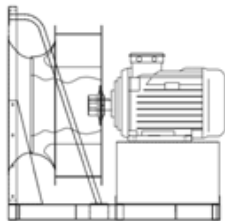

Direct Driven 'D'

This type is supplied with no belts nor pulley and therefore minimal maintenance is required. It is a compact, space saving design with motor directly connected to wheel. This construction is mainly for cleanroom, with or without VFD, since there is an absence of belt residue which may contaminate the airstreams.

Fan Size : 315 to 1,800
Volume : 3,000 to 300,000 m³/h
Total Pressure : up to 4,500 Pa

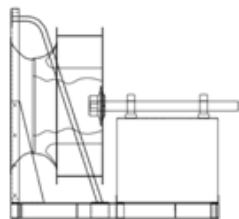

Belt Driven 'B'

No bearings in the fan inlet to affect performance. Separate base for motor mounting is required.

Fan Size : 315 to 1,800
Volume : 3,000 to 300,000 m³/h
Total Pressure : up to 4,500 Pa

Drawings and dimension data of belt driven are available upon request.

TECHNICAL SPECIFICATION

Wheel

The wheels of BNC series have backward curved blades manufactured in mild steel with polyester powder coating finish.

Shaft

Shafts are manufactured from C45 carbon steel using an automatic process for positioning and cutting of the keyways. All dimensional tolerances of the shaft are fully checked to ensure a precision fit. All shafts are then coated with an anti-corrosion varnish after assembly.

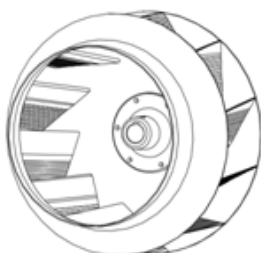

Bearing

Bearings used are either deep groove ball bearings with an adapter sleeve, or spherical roller bearings sealed at both sides for different duty application.

The bearings are lubricated for life and maintenance-free. If relubrication is necessary, it is recommended to use lithium base grease suitable for all temperatures within the operational limits.

Balancing Quality

All wheels are statically and dynamically balanced to ISO1940 and AMCA 204 – G2.5 standard.

All fans after assembly are trim-balanced to ISO1940 and AMCA 204 - G2.5 standard.

Other standard rather than G2.5 is available upon request.

ACCESSORIES

Inlet Guard

Inlet guards may be a requirement in some industrial safety regulations. These are available upon request.

Motor Selection

The power curves shown on each performance graph represents the absorbed power at the shaft of the fan measured in kW.

To determine the power of the motor to be installed, a correction factor should be applied to compensate for the transmission loss.

For conversion to horsepower (HP), use multiplying factor 1.34.

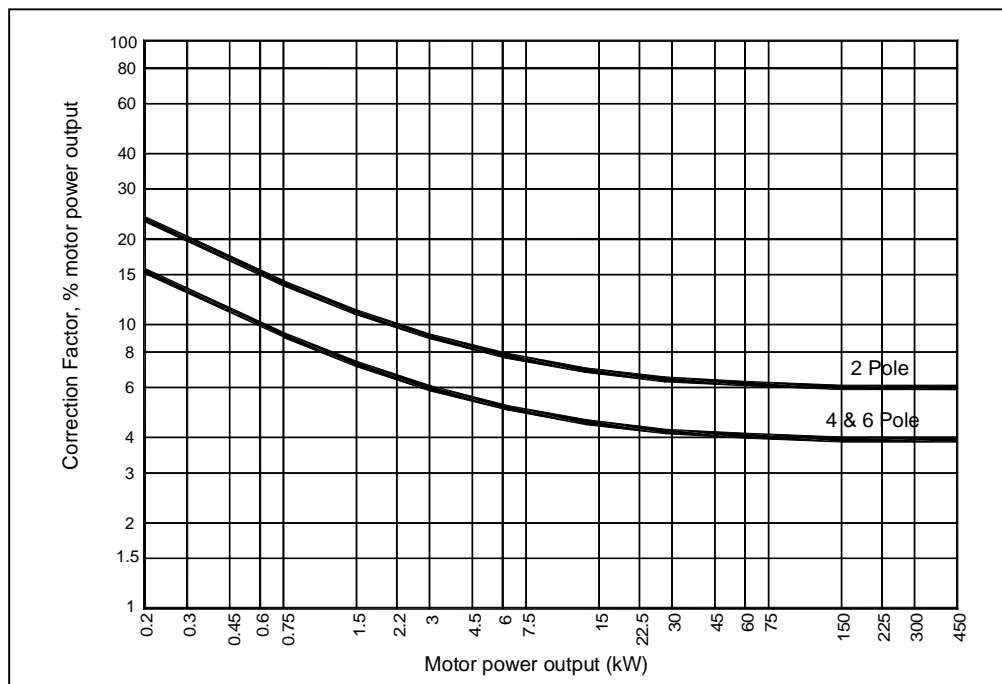

PERFORMANCE

The performance data shown on each diagram is derived from tests conducted in accordance with AMCA Standard 210 Fig 15 Installation type A (free inlet and free outlet condition).

Ratings refer to standard air density with the total pressure as a function of the air volume, using logarithmic scale.

It is essential that, the same installation type and test standards are used at all times, when comparing fan performance.

According to ISO 12759/AMCA 205, BNC series can be classified as FEG 80 based on fan peak efficiency. The following is the explanation of FEG classification:

1. Fan size is the impeller diameter in mm.
2. The fan peak efficiency shall be calculated from the fan (total) pressure.
3. If this method is used for a direct driven fan, the fan efficiency is the impeller efficiency.
4. The FEG label for a given fan size is assigned when the fan peak efficiency is equal or lower than the efficiency at the grade upper limit and higher than efficiency at the grade upper limit of the next lower grade for the fan size.
5. For any fan sizes larger than 1016 mm, the values of the grade upper limits are the same as for a size of 1016 mm.
6. No labels are considered for the fans with the fan peak total efficiency below FEG50.
7. The values of efficiencies are calculated for fan sizes in the preferred R40 Series.
8. Not all fan sizes in preferred numbers shown.

Fan Efficiency Grades (FEG) for Fans without Drives (SI) – ISO 12759/AMCA 205

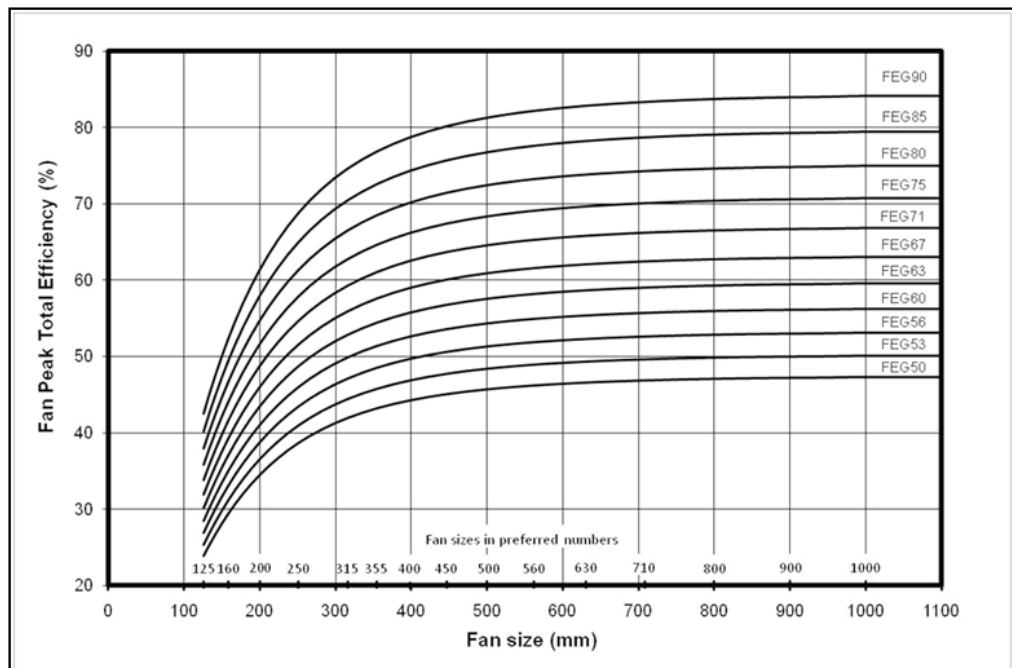

NOISE

The noise levels shown on each diagram refer to the sound power, "A-weighted" values and the data are obtained at the outlet side from tests conducted in accordance to AMCA Standard 300. The noise levels are determined as follow:

- n Sound power level - ("A" scale): $L_w(A)$ as catalogue
- n Octave band spectrum: $L_w = L_w(A) + L_w \text{ rel. dB}$ [refer to Kruger for more details]
- n Sound pressure level:
 - a) free field
 $L_p(A) = L_w(A) - (20\log_{10}d) - 11$
 - b) room conditions
 $L_p(A) = L_w(A) - (20\log_{10}d) - 7$where d = distance of fan (m)

Example of Selection

- Air Volume $Q=5000\text{m}^3/\text{h}$
- Outlet Velocity $V=8.8\text{m/s}$
- Dynamic Pressure $P_d=48\text{Pa}$
- Total Pressure $P_t=900\text{Pa}$
- Fan Speed $N=2200\text{rpm}$
- Absorbed Power $W=1.7\text{kW}$
- Total Efficiency $\eta=72\%$
- Sound Power Level $L_w(A)=92.5\text{dB(A)}$

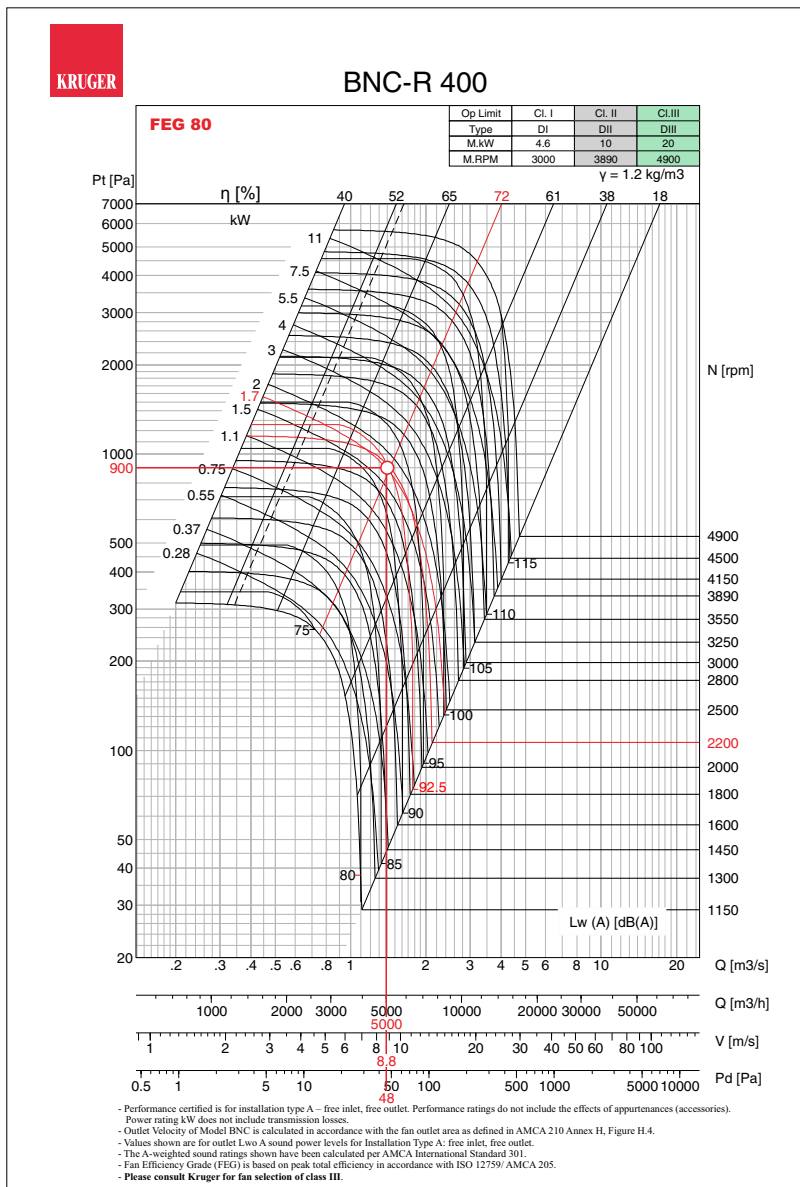



BNC-P 315

FEG 80

Op Limit	Cl. I	Cl. II	Cl. III
Type	DI	DII	DIII
M.kW	2.2	5	9.7
M.RPM	3500	4600	5800

$\gamma = 1.2 \text{ kg/m}^3$

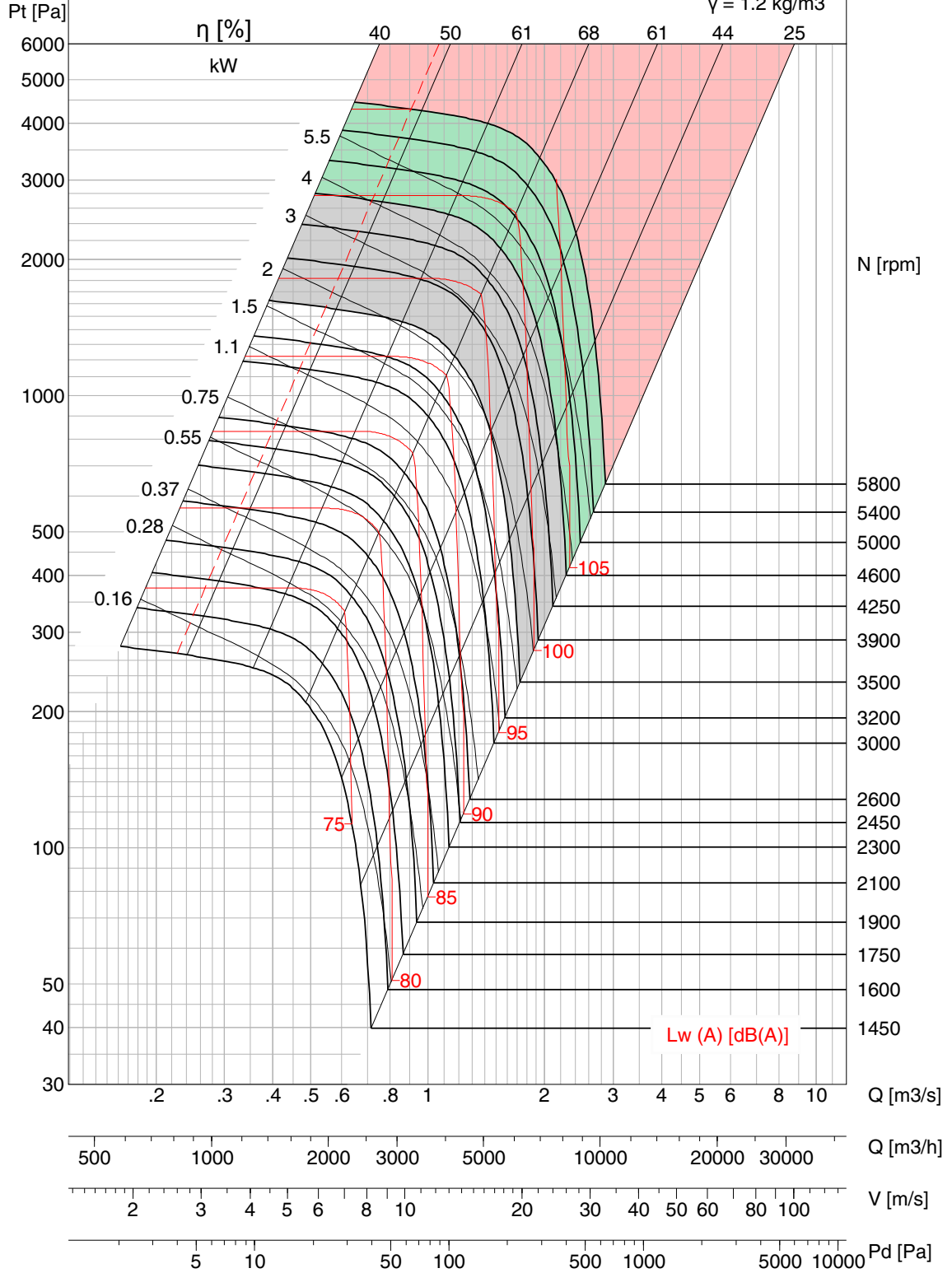

- Performance certified is for installation type A – free inlet, free outlet. Performance ratings do not include the effects of appurtenances (accessories). Power rating kW does not include transmission losses.
- Outlet Velocity of Model BNC is calculated in accordance with the fan outlet area as defined in AMCA 210 Annex H, Figure H.4.
- Values shown are for outlet Lwo A sound power levels for Installation Type A: free inlet, free outlet.
- The A-weighted sound ratings shown have been calculated per AMCA International Standard 301.
- Fan Efficiency Grade (FEG) is based on peak total efficiency in accordance with ISO 12759/ AMCA 205.
- Please consult Kruger for fan selection of class III.



BNC-R 315

FEG 80

Op Limit	Cl. I	Cl. II	Cl. III
Type	DI	DII	DIII
M.kW	2.4	5.2	10.4
M.RPM	3550	4600	5800

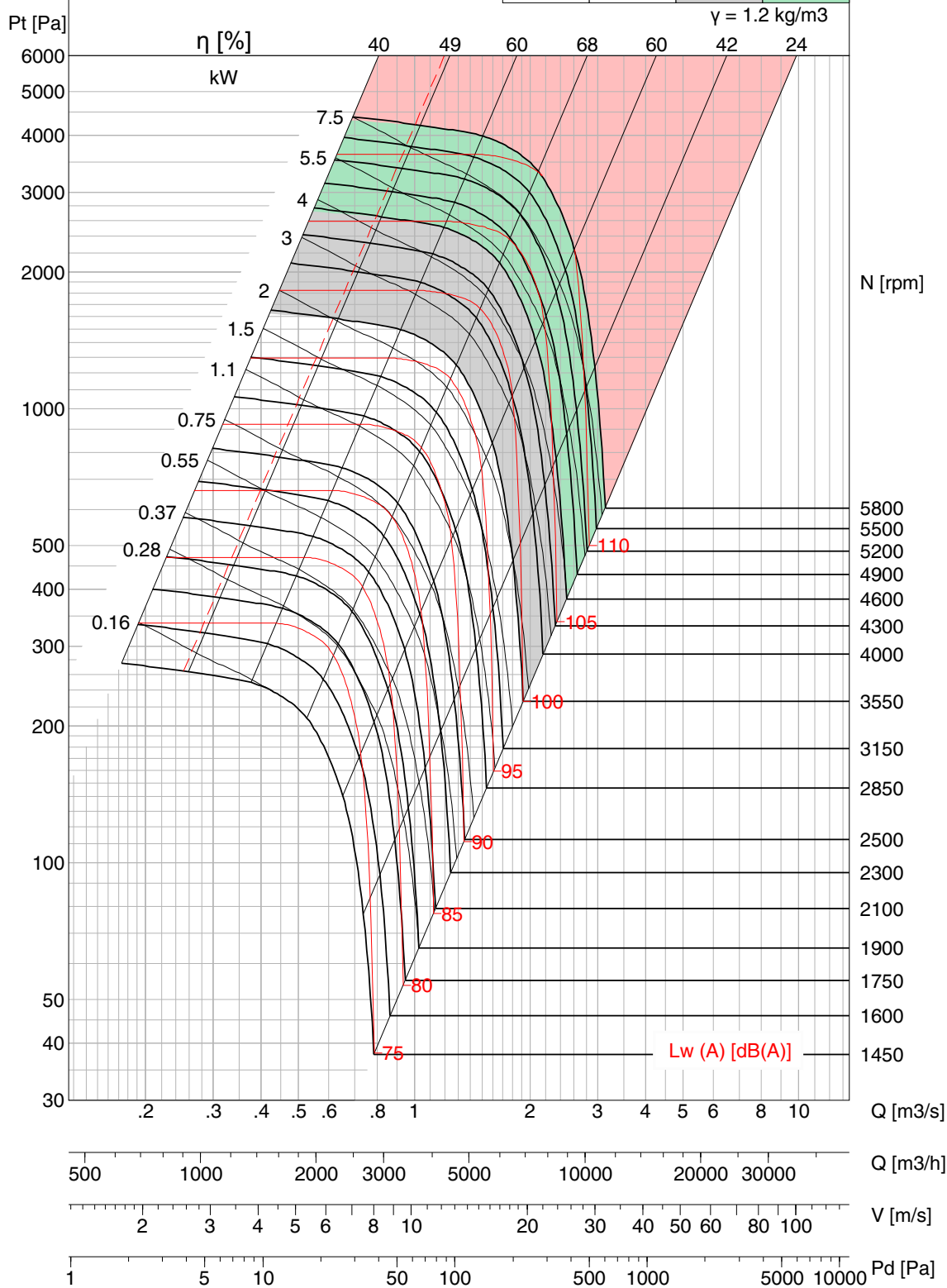

- Performance certified is for installation type A – free inlet, free outlet. Performance ratings do not include the effects of appurtenances (accessories).
- Power rating kW does not include transmission losses.
- Outlet Velocity of Model BNC is calculated in accordance with the fan outlet area as defined in AMCA 210 Annex H, Figure H.4.
- Values shown are for outlet Lwo A sound power levels for Installation Type A: free inlet, free outlet.
- The A-weighted sound ratings shown have been calculated per AMCA International Standard 301.
- Fan Efficiency Grade (FEG) is based on peak total efficiency in accordance with ISO 12759/ AMCA 205.
- Please consult Kruger for fan selection of class III.



BNC-Q 315

FEG 80

Op Limit	Cl. I	Cl. II	Cl. III
Type	DI	DII	DIII
M.kW	3	6.5	13
M.RPM	3700	4800	6100

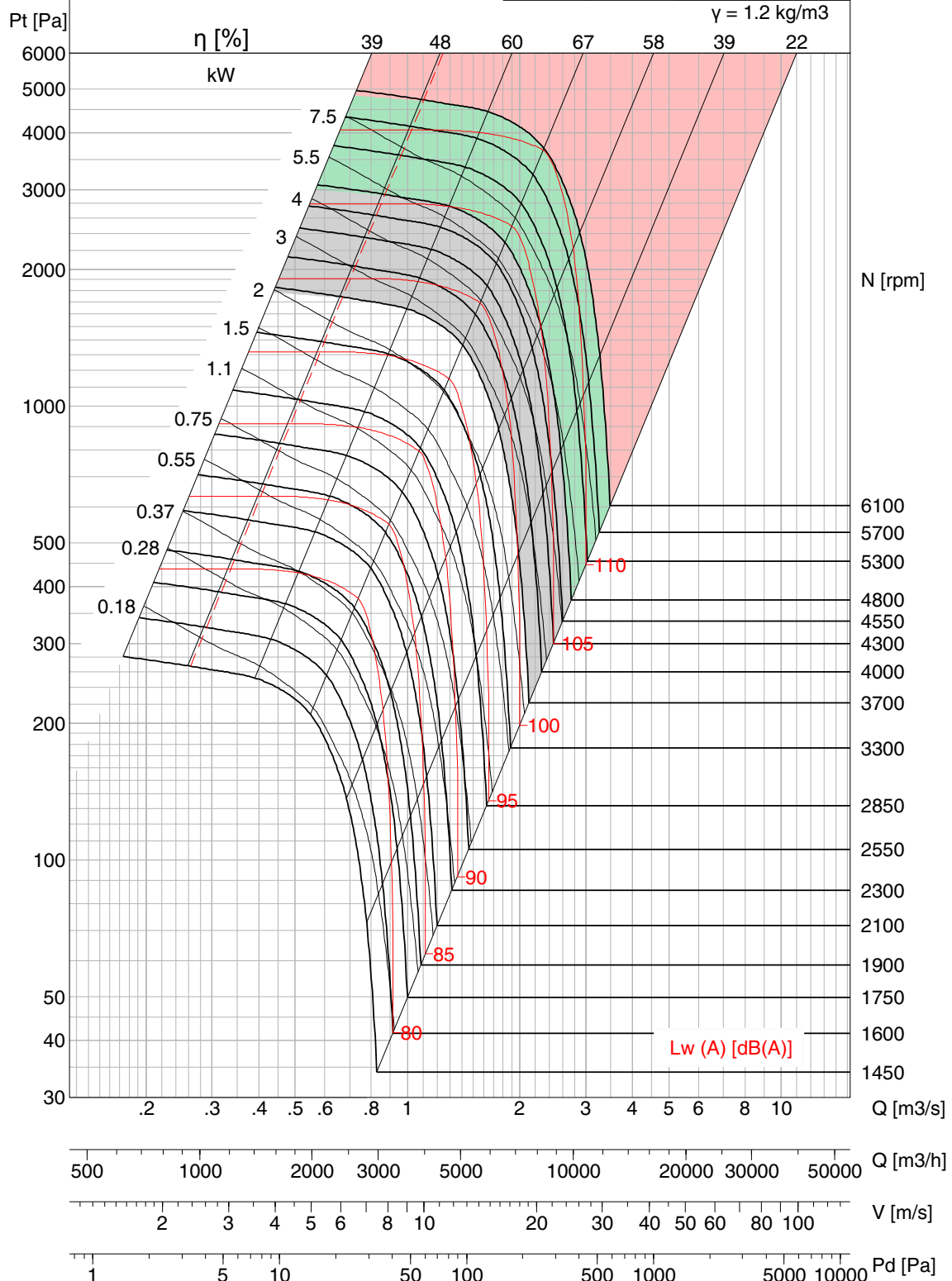

- Performance certified is for installation type A – free inlet, free outlet. Performance ratings do not include the effects of appurtenances (accessories).
- Power rating kW does not include transmission losses.
- Outlet Velocity of Model BNC is calculated in accordance with the fan outlet area as defined in AMCA 210 Annex H, Figure H.4.
- Values shown are for outlet Lwo A sound power levels for Installation Type A: free inlet, free outlet.
- The A-weighted sound ratings shown have been calculated per AMCA International Standard 301.
- Fan Efficiency Grade (FEG) is based on peak total efficiency in accordance with ISO 12759/ AMCA 205.
- Please consult Kruger for fan selection of class III.



BNC-P 355

FEG 80

Op Limit	Cl. I	Cl. II	Cl. III
Type	DI	DII	DIII
M.kW	3	6	11.5
M.RPM	3100	4000	5000

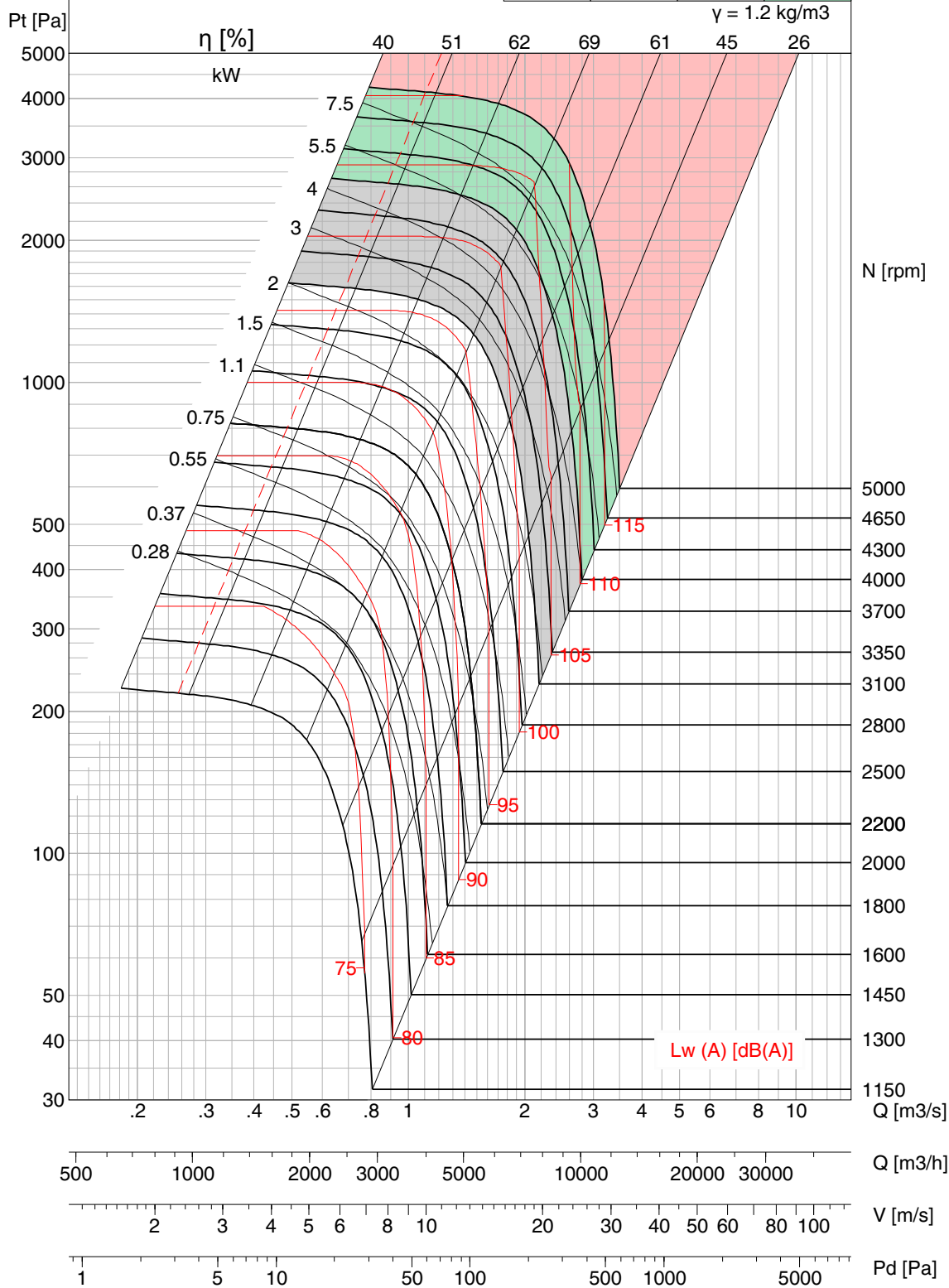

- Performance certified is for installation type A – free inlet, free outlet. Performance ratings do not include the effects of appurtenances (accessories).
- Power rating kW does not include transmission losses.
- Outlet Velocity of Model BNC is calculated in accordance with the fan outlet area as defined in AMCA 210 Annex H, Figure H.4.
- Values shown are for outlet Lwo A sound power levels for Installation Type A: free inlet, free outlet.
- The A-weighted sound ratings shown have been calculated per AMCA International Standard 301.
- Fan Efficiency Grade (FEG) is based on peak total efficiency in accordance with ISO 12759/ AMCA 205.
- Please consult Kruger for fan selection of class III.



BNC-R 355

FEG 80

Op Limit	Cl. I	Cl. II	Cl. III
Type	DI	DII	DIII
M.kW	3	6.8	13.3
M.RPM	3180	4150	5200

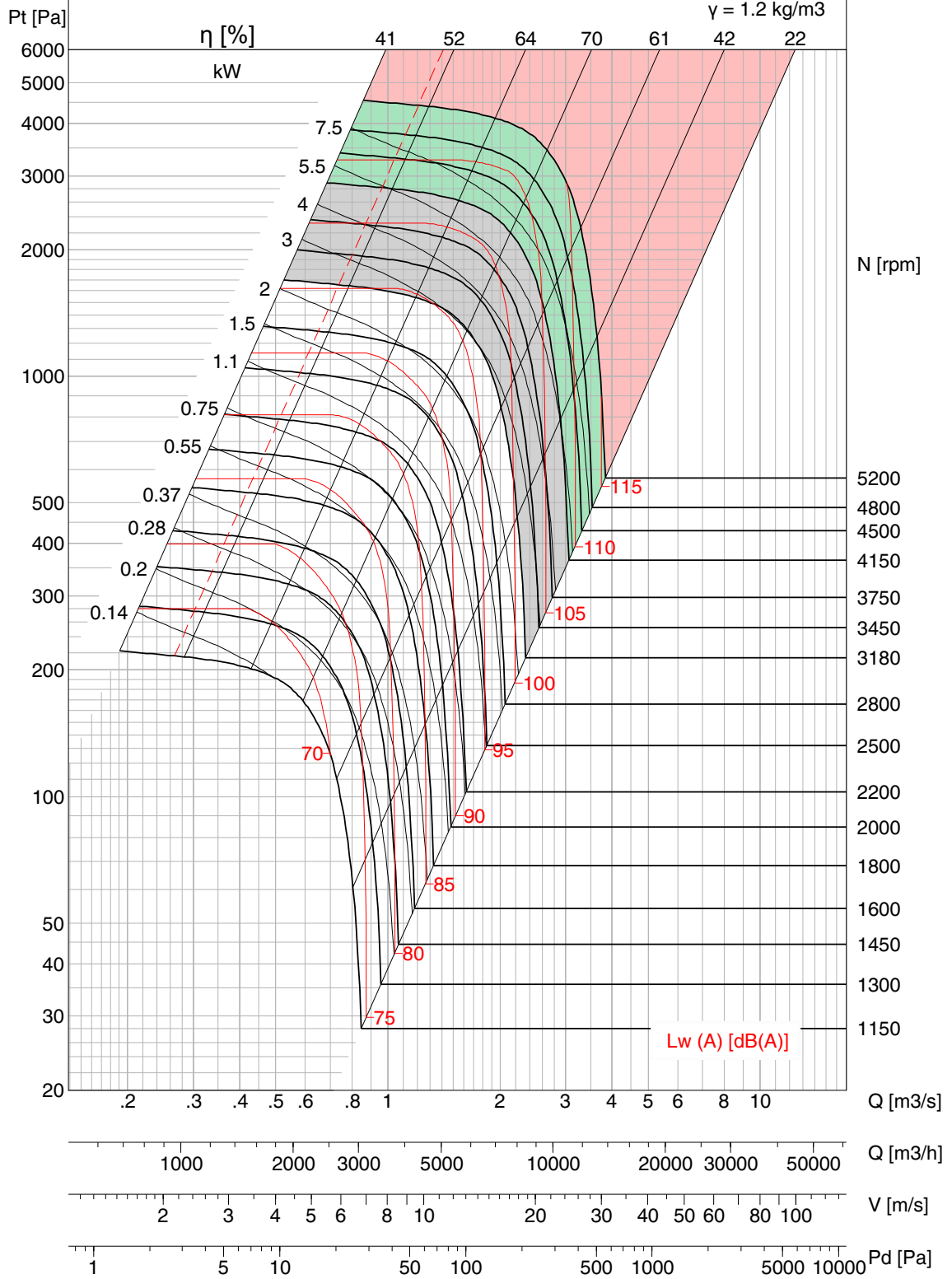

- Performance certified is for installation type A – free inlet, free outlet. Performance ratings do not include the effects of appurtenances (accessories).
- Power rating kW does not include transmission losses.
- Outlet Velocity of Model BNC is calculated in accordance with the fan outlet area as defined in AMCA 210 Annex H, Figure H.4.
- Values shown are for outlet Lwo A sound power levels for Installation Type A: free inlet, free outlet.
- The A-weighted sound ratings shown have been calculated per AMCA International Standard 301.
- Fan Efficiency Grade (FEG) is based on peak total efficiency in accordance with ISO 12759/ AMCA 205.
- Please consult Kruger for fan selection of class III.



BNC-Q 355

FEG 80

Op Limit	Cl. I	Cl. II	Cl. III
Type	DI	DII	DIII
M.kW	4	8.6	17
M.RPM	3370	4370	5500

$\gamma = 1.2 \text{ kg/m}^3$

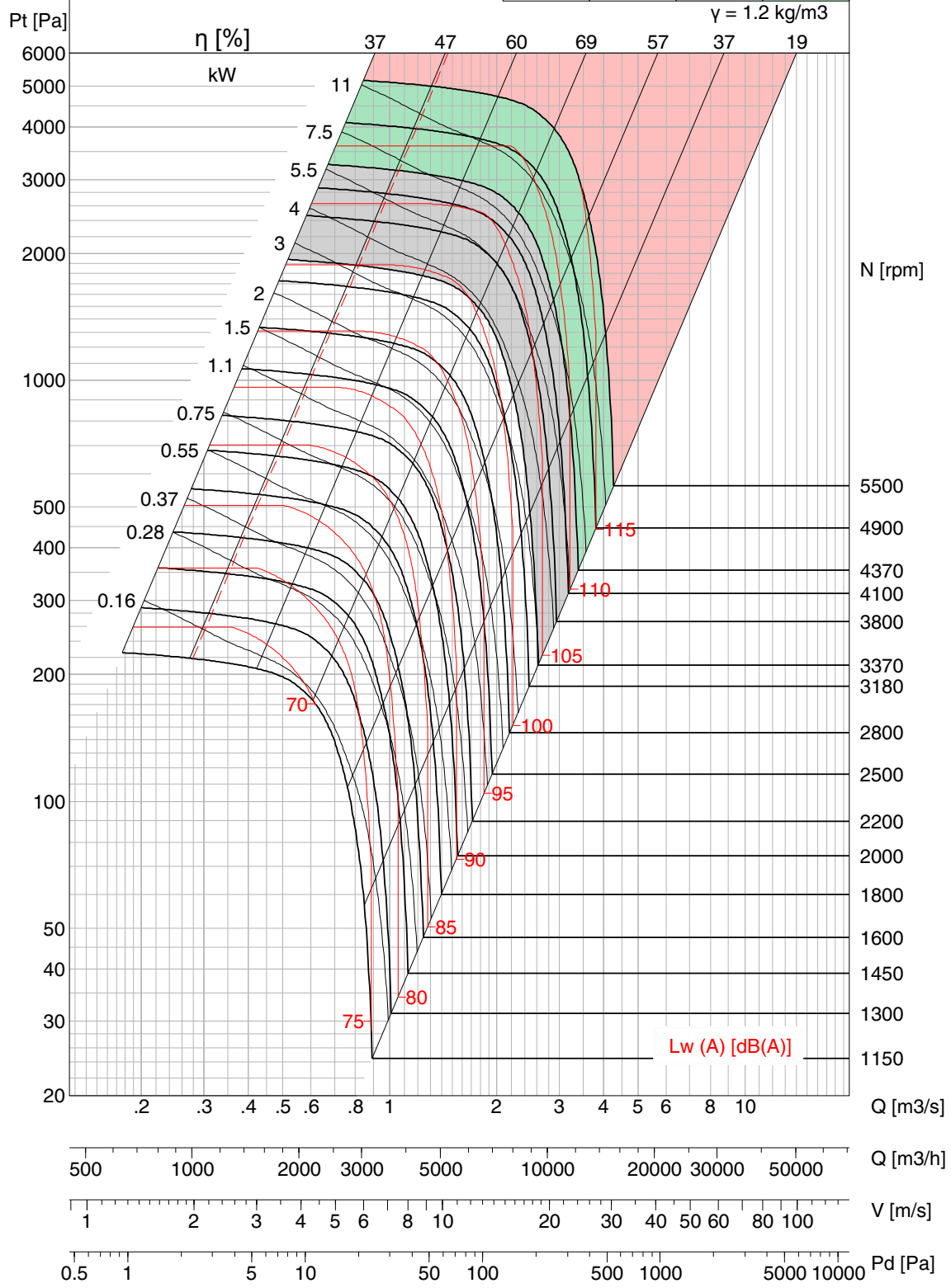

- Performance certified is for installation type A – free inlet, free outlet. Performance ratings do not include the effects of appurtenances (accessories).
- Power rating kW does not include transmission losses.
- Outlet Velocity of Model BNC is calculated in accordance with the fan outlet area as defined in AMCA 210 Annex H, Figure H.4.
- Values shown are for outlet Lwo A sound power levels for Installation Type A: free inlet, free outlet.
- The A-weighted sound ratings shown have been calculated per AMCA International Standard 301.
- Fan Efficiency Grade (FEG) is based on peak total efficiency in accordance with ISO 12759/ AMCA 205.
- Please consult Kruger for fan selection of class III.



BNC-P 400

FEG 80

Op Limit	Cl. I	Cl. II	Cl. III
Type	DI	DII	DIII
M.kW	3.3	7.2	14
M.RPM	2750	3550	4450

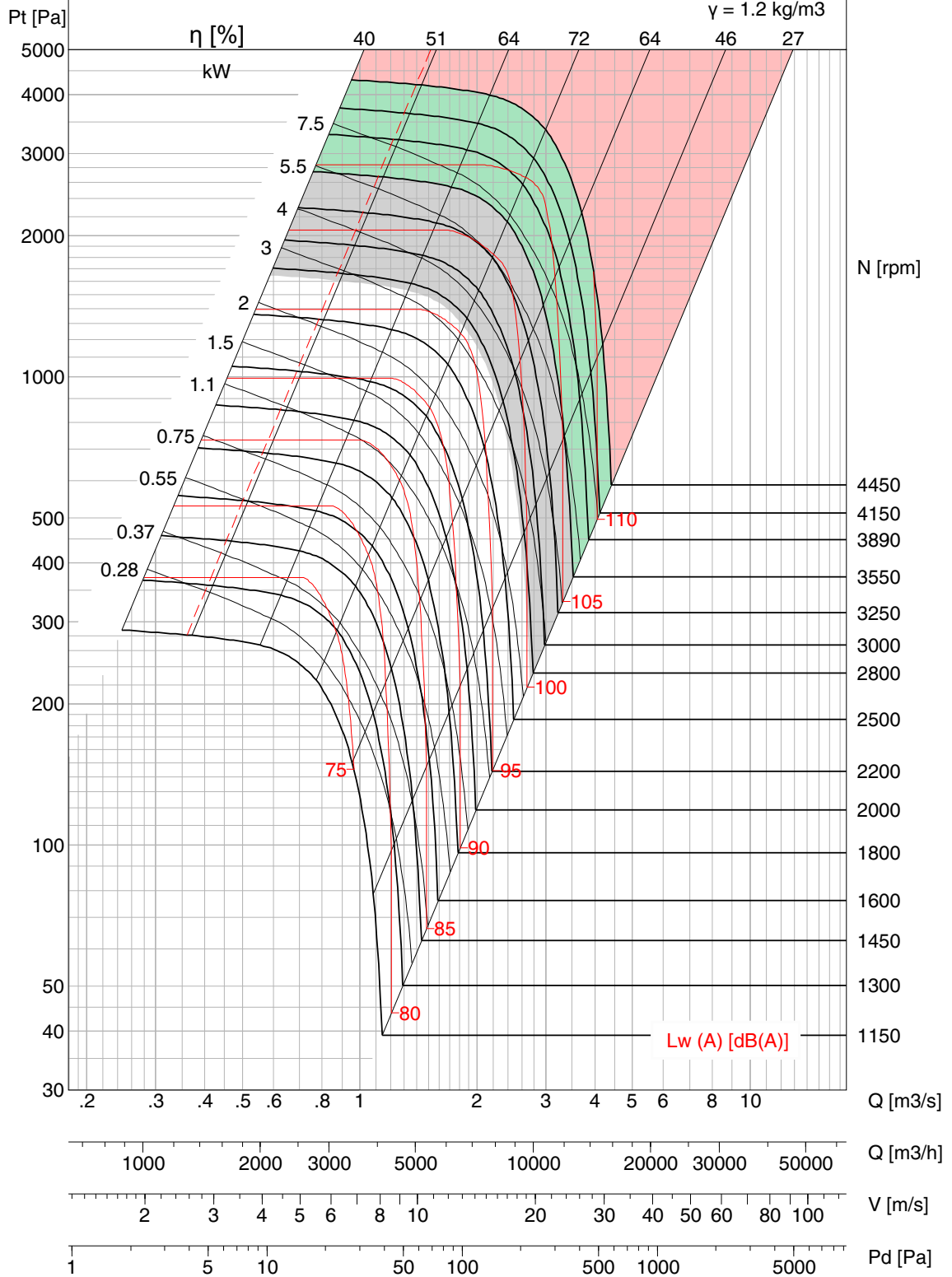

- Performance certified is for installation type A – free inlet, free outlet. Performance ratings do not include the effects of appurtenances (accessories). Power rating kW does not include transmission losses.
- Outlet Velocity of Model BNC is calculated in accordance with the fan outlet area as defined in AMCA 210 Annex H, Figure H.4.
- Values shown are for outlet Lwo A sound power levels for Installation Type A: free inlet, free outlet.
- The A-weighted sound ratings shown have been calculated per AMCA International Standard 301.
- Fan Efficiency Grade (FEG) is based on peak total efficiency in accordance with ISO 12759/ AMCA 205.
- Please consult Kruger for fan selection of class III.



BNC-R 400

FEG 80

Op Limit	Cl. I	Cl. II	Cl. III
Type	DI	DII	DIII
M.kW	4.6	10	20
M.RPM	3000	3890	4900

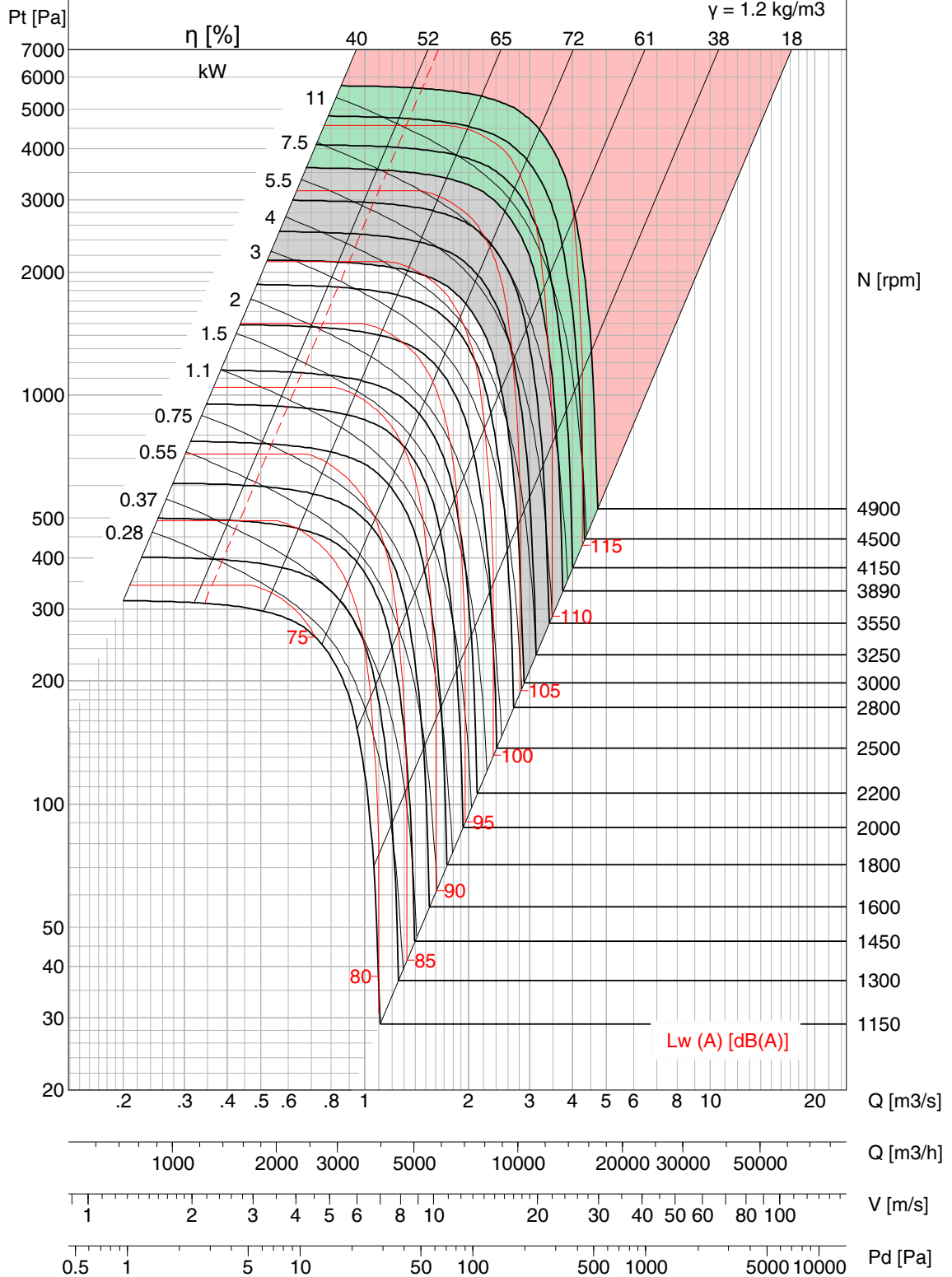

- Performance certified is for installation type A – free inlet, free outlet. Performance ratings do not include the effects of appurtenances (accessories). Power rating kW does not include transmission losses.
- Outlet Velocity of Model BNC is calculated in accordance with the fan outlet area as defined in AMCA 210 Annex H, Figure H.4.
- Values shown are for outlet Lwo A sound power levels for Installation Type A: free inlet, free outlet.
- The A-weighted sound ratings shown have been calculated per AMCA International Standard 301.
- Fan Efficiency Grade (FEG) is based on peak total efficiency in accordance with ISO 12759/ AMCA 205.
- Please consult Kruger for fan selection of class III.



BNC-Q 400

FEG 80

Op Limit	Cl. I	Cl. II	Cl. III
Type	DI	DII	DIII
M.kW	5	11	22
M.RPM	2900	3750	4750

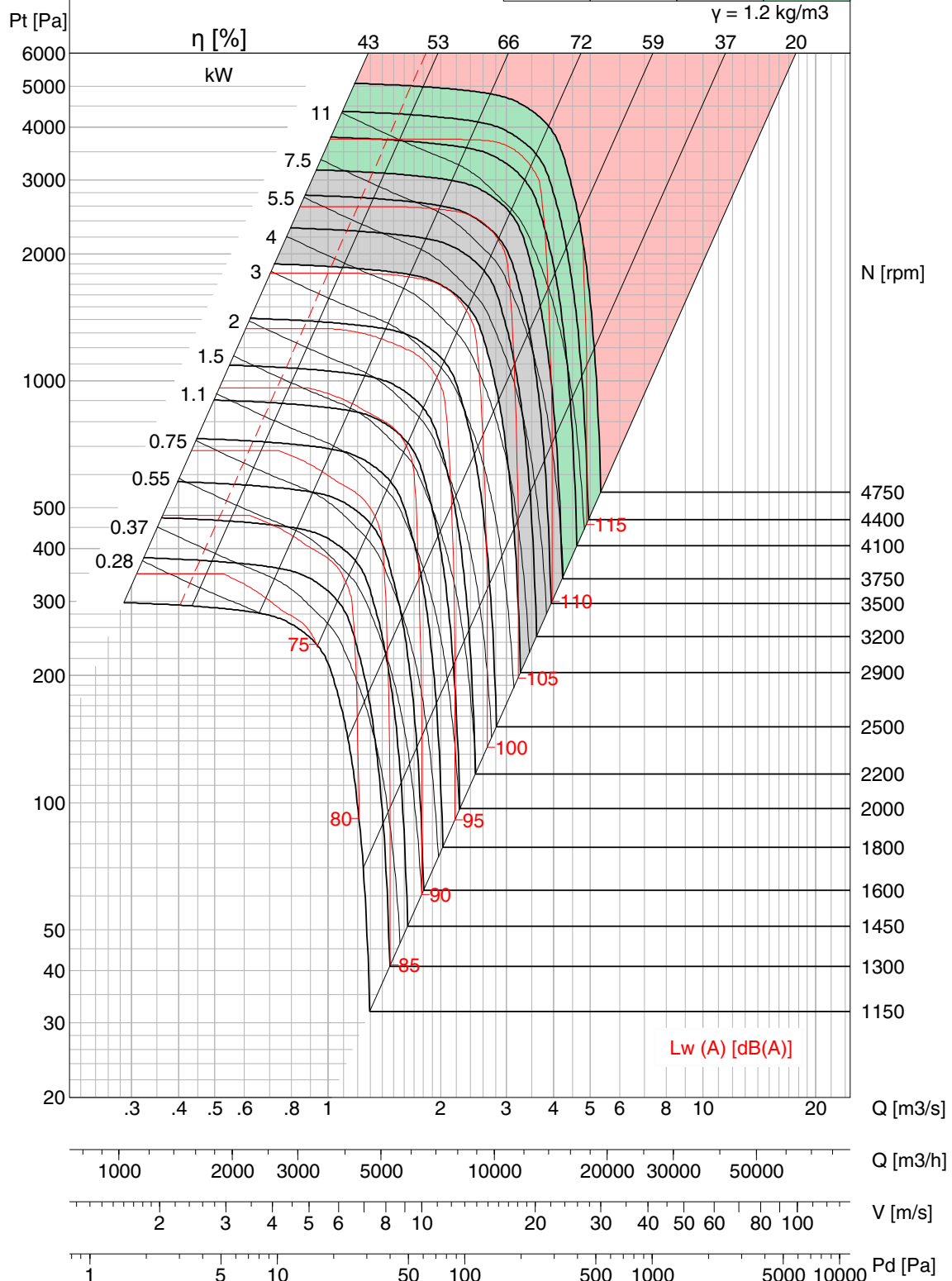

- Performance certified is for installation type A – free inlet, free outlet. Performance ratings do not include the effects of appurtenances (accessories).
- Power rating kW does not include transmission losses.
- Outlet Velocity of Model BNC is calculated in accordance with the fan outlet area as defined in AMCA 210 Annex H, Figure H.4.
- Values shown are for outlet Lwo A sound power levels for Installation Type A: free inlet, free outlet.
- The A-weighted sound ratings shown have been calculated per AMCA International Standard 301.
- Fan Efficiency Grade (FEG) is based on peak total efficiency in accordance with ISO 12759/ AMCA 205.
- Please consult Kruger for fan selection of class III.



BNC-P 450

FEG 80

Op Limit	Cl. I	Cl. II	Cl. III
Type	DI	DII	DIII
M.kW	4.3	9.5	19
M.RPM	2450	3170	4000

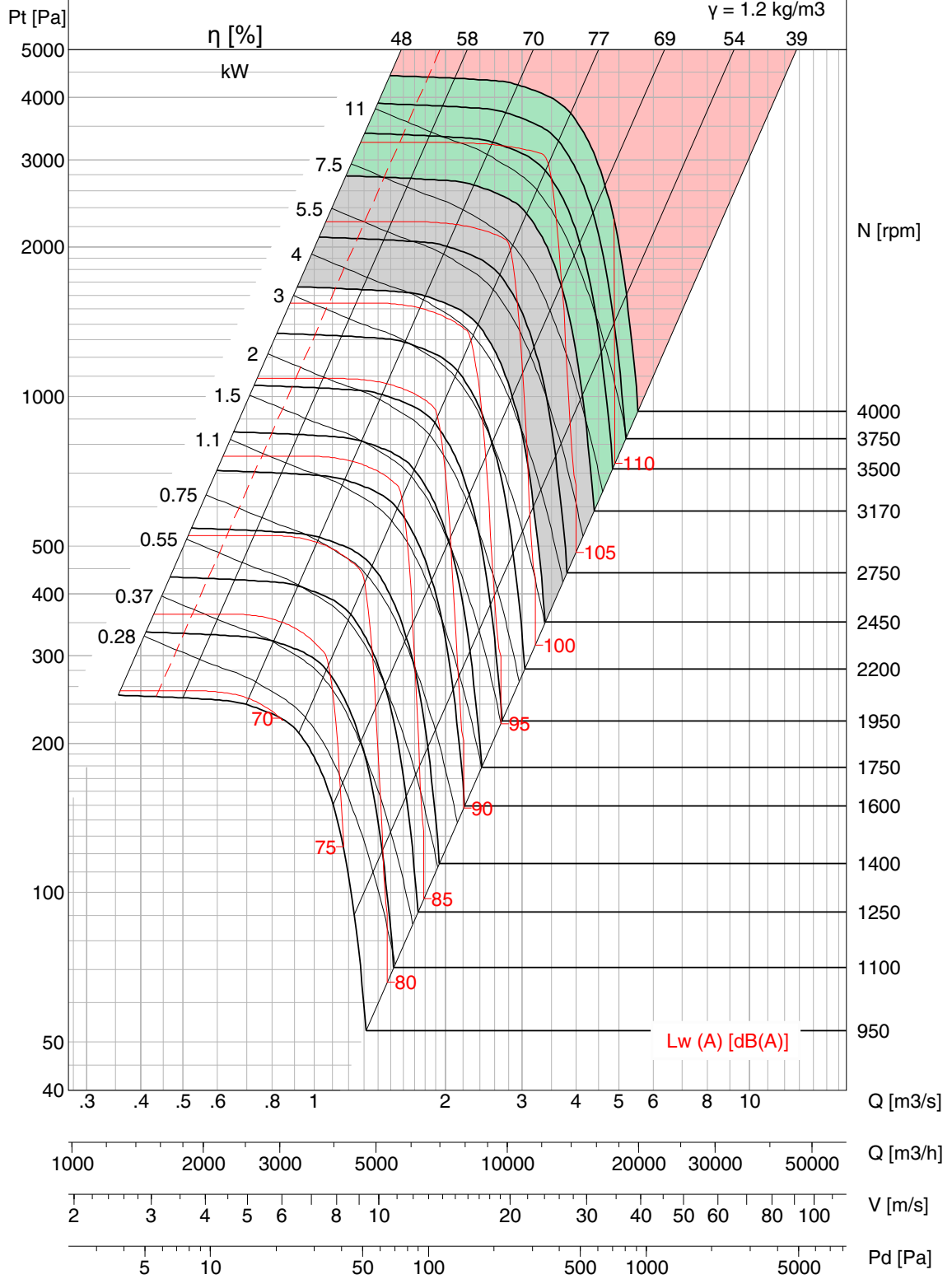

- Performance certified is for installation type A – free inlet, free outlet. Performance ratings do not include the effects of appurtenances (accessories).
- Power rating kW does not include transmission losses.
- Outlet Velocity of Model BNC is calculated in accordance with the fan outlet area as defined in AMCA 210 Annex H, Figure H.4.
- Values shown are for outlet Lwo A sound power levels for Installation Type A: free inlet, free outlet.
- The A-weighted sound ratings shown have been calculated per AMCA International Standard 301.
- Fan Efficiency Grade (FEG) is based on peak total efficiency in accordance with ISO 12759/ AMCA 205.
- Please consult Kruger for fan selection of class III.



BNC-R 450

FEG 80

Op Limit	Cl. I	Cl. II	Cl. III
Type	DI	DII	DIII
M.kW	4.6	10.6	21.5
M.RPM	2470	3200	4050

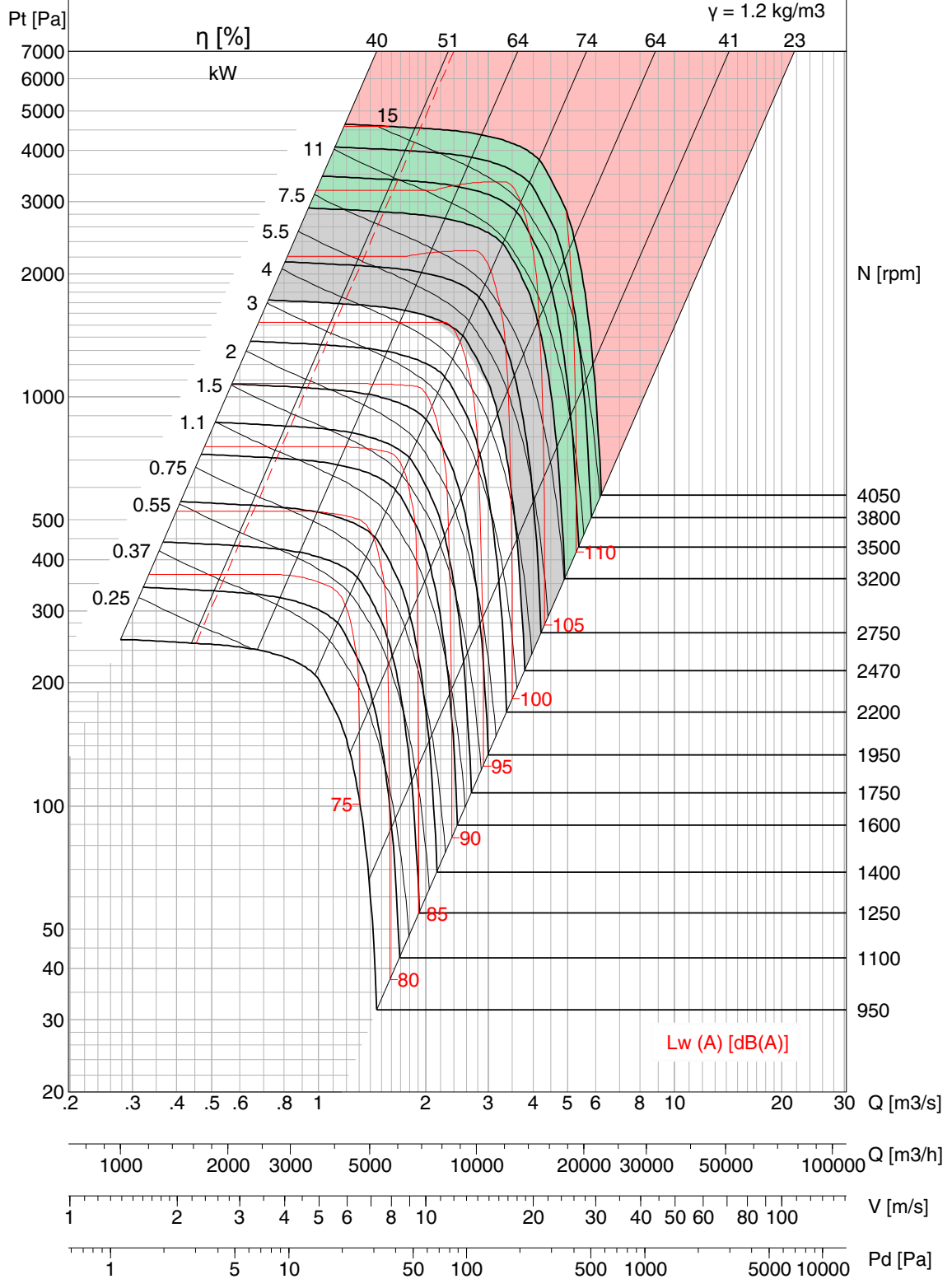

- Performance certified is for installation type A – free inlet, free outlet. Performance ratings do not include the effects of appurtenances (accessories). Power rating kW does not include transmission losses.
- Outlet Velocity of Model BNC is calculated in accordance with the fan outlet area as defined in AMCA 210 Annex H, Figure H.4.
- Values shown are for outlet Lwo A sound power levels for Installation Type A: free inlet, free outlet.
- The A-weighted sound ratings shown have been calculated per AMCA International Standard 301.
- Fan Efficiency Grade (FEG) is based on peak total efficiency in accordance with ISO 12759/ AMCA 205.
- Please consult Kruger for fan selection of class III.



BNC-Q 450

FEG 80

Op Limit	Cl. I	Cl. II	Cl. III
Type	DI	DII	DIII
M.kW	6.1	13.6	27.5
M.RPM	2600	3400	4300

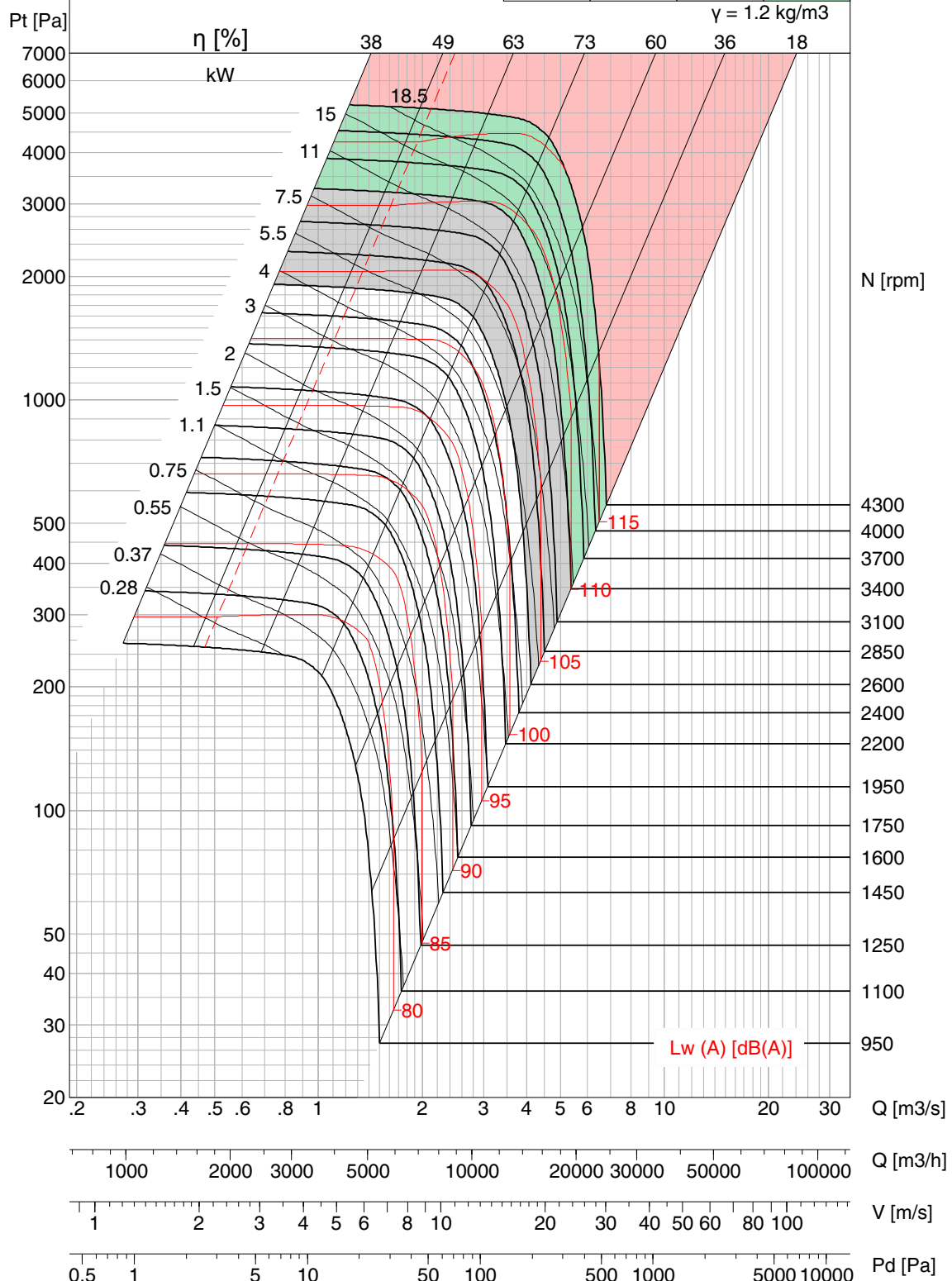

- Performance certified is for installation type A – free inlet, free outlet. Performance ratings do not include the effects of appurtenances (accessories). Power rating kW does not include transmission losses.
- Outlet Velocity of Model BNC is calculated in accordance with the fan outlet area as defined in AMCA 210 Annex H, Figure H.4.
- Values shown are for outlet Lwo A sound power levels for Installation Type A: free inlet, free outlet.
- The A-weighted sound ratings shown have been calculated per AMCA International Standard 301.
- Fan Efficiency Grade (FEG) is based on peak total efficiency in accordance with ISO 12759/ AMCA 205.
- Please consult Kruger for fan selection of class III.



BNC-P 500

FEG 80

Op Limit	Cl. I	Cl. II	Cl. III
Type	DI	DII	DIII
M.kW	5.3	11.5	23.2
M.RPM	2200	2850	3600

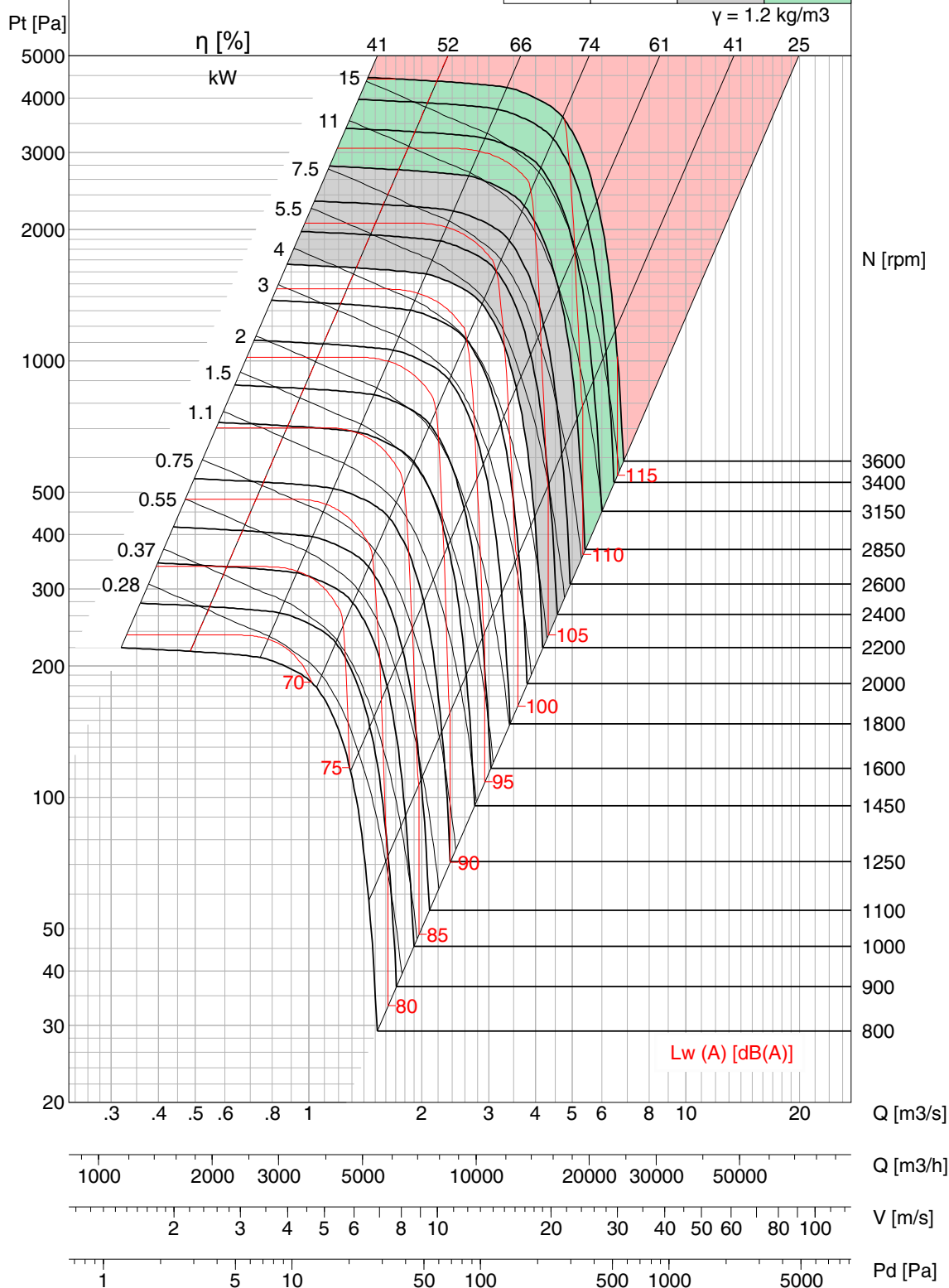

- Performance certified is for installation type A – free inlet, free outlet. Performance ratings do not include the effects of appurtenances (accessories).
- Power rating kW does not include transmission losses.
- Outlet Velocity of Model BNC is calculated in accordance with the fan outlet area as defined in AMCA 210 Annex H, Figure H.4.
- Values shown are for outlet Lwo A sound power levels for Installation Type A: free inlet, free outlet.
- The A-weighted sound ratings shown have been calculated per AMCA International Standard 301.
- Fan Efficiency Grade (FEG) is based on peak total efficiency in accordance with ISO 12759/ AMCA 205.
- Please consult Kruger for fan selection of class III.



BNC-R 500

FEG 80

Op Limit	Cl. I	Cl. II	Cl. III
Type	DI	DII	DIII
M.kW	6	13	27
M.RPM	2220	2880	3650

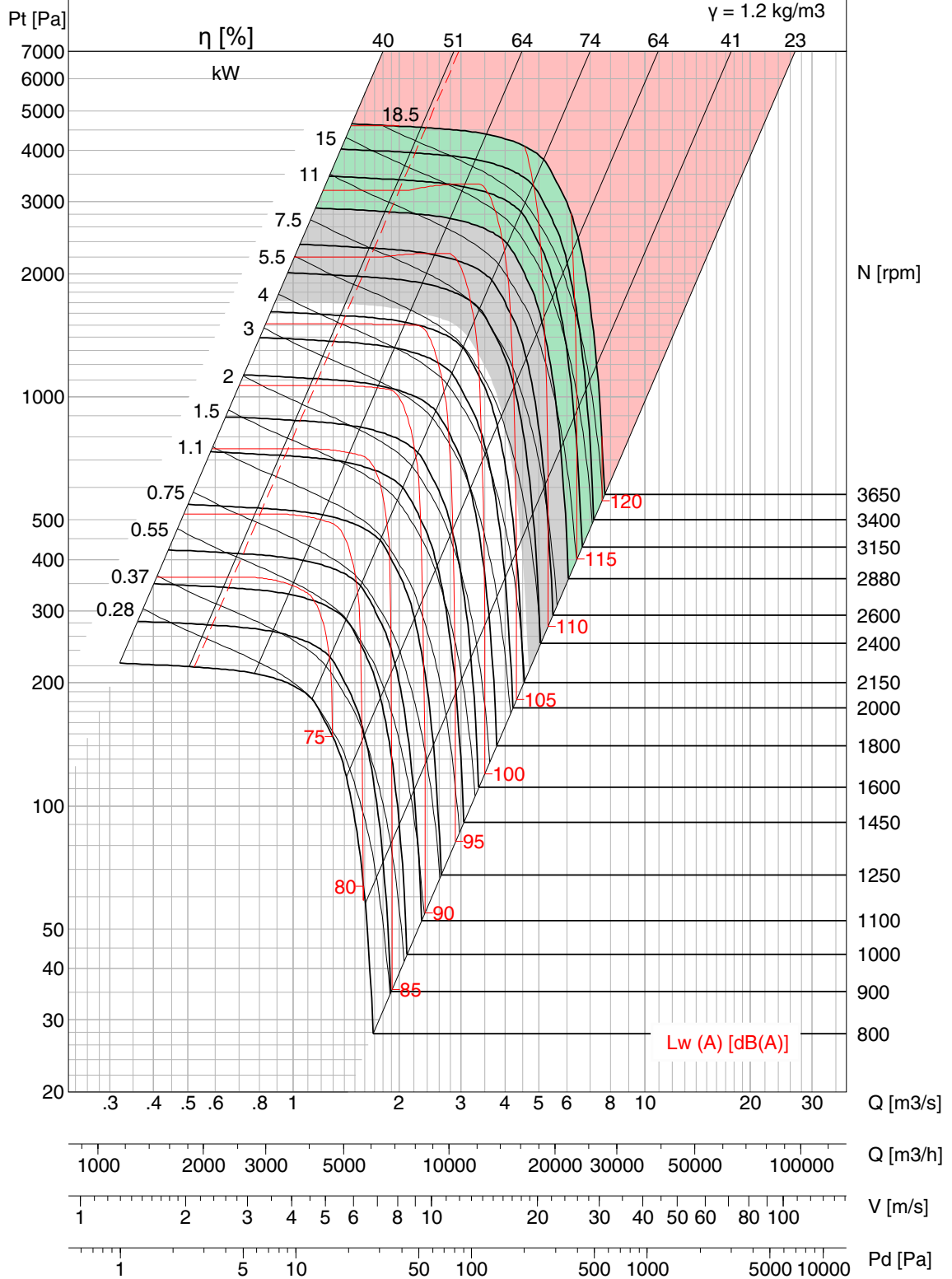

- Performance certified is for installation type A – free inlet, free outlet. Performance ratings do not include the effects of appurtenances (accessories). Power rating kW does not include transmission losses.
- Outlet Velocity of Model BNC is calculated in accordance with the fan outlet area as defined in AMCA 210 Annex H, Figure H.4.
- Values shown are for outlet Lwo A sound power levels for Installation Type A: free inlet, free outlet.
- The A-weighted sound ratings shown have been calculated per AMCA International Standard 301.
- Fan Efficiency Grade (FEG) is based on peak total efficiency in accordance with ISO 12759/ AMCA 205.
- Please consult Kruger for fan selection of class III.



BNC-Q 500

FEG 80

Op Limit	Cl. I	Cl. II	Cl. III
Type	DI	DII	DIII
M.kW	7.6	16.7	33.5
M.RPM	2350	3050	3850

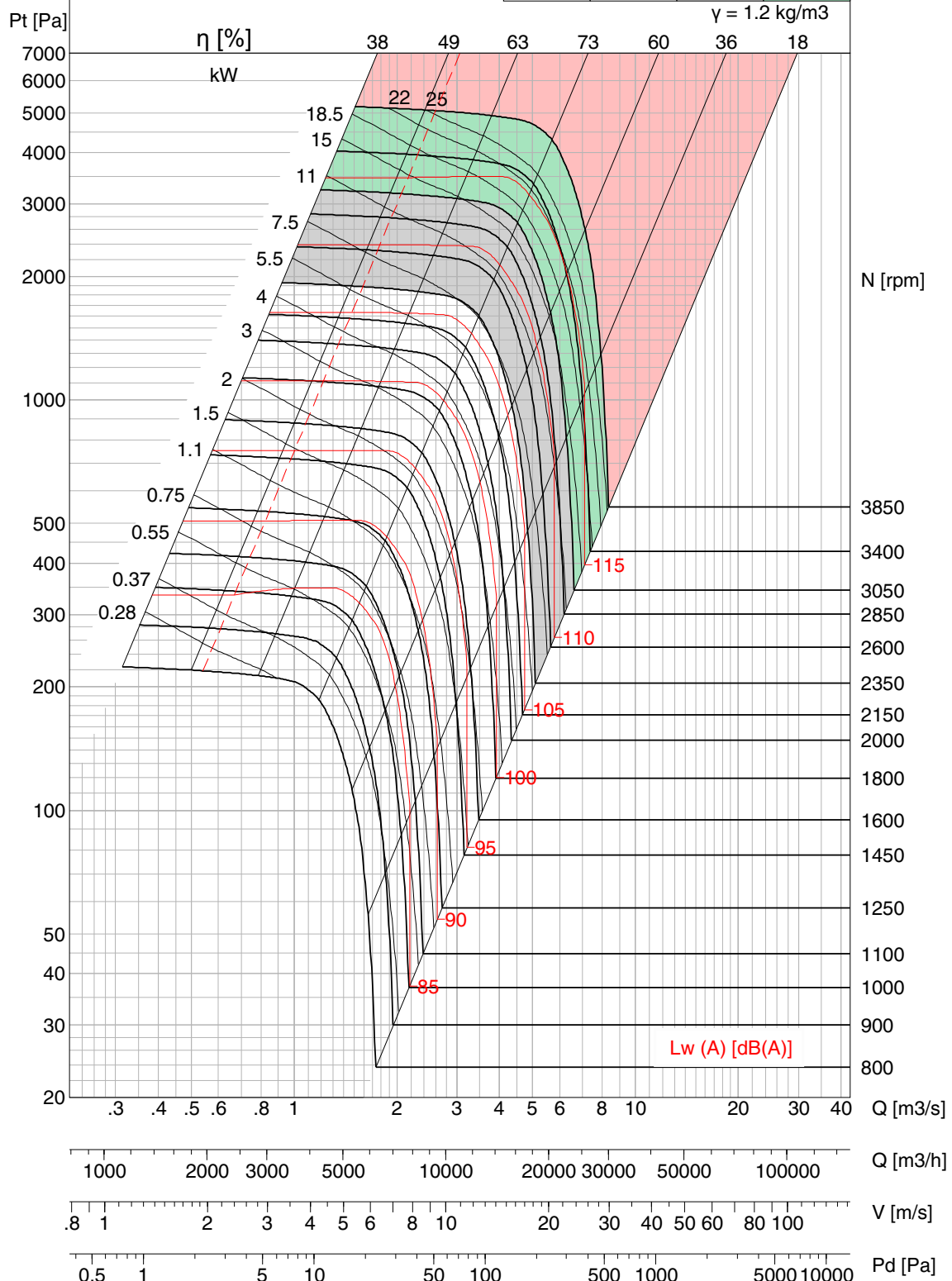

- Performance certified is for installation type A – free inlet, free outlet. Performance ratings do not include the effects of appurtenances (accessories).
- Power rating kW does not include transmission losses.
- Outlet Velocity of Model BNC is calculated in accordance with the fan outlet area as defined in AMCA 210 Annex H, Figure H.4.
- Values shown are for outlet Lwo A sound power levels for Installation Type A: free inlet, free outlet.
- The A-weighted sound ratings shown have been calculated per AMCA International Standard 301.
- Fan Efficiency Grade (FEG) is based on peak total efficiency in accordance with ISO 12759/ AMCA 205.
- Please consult Kruger for fan selection of class III.



BNC-P 560

FEG 80

Op Limit	Cl. I	Cl. II	Cl. III
Type	DI	DII	DIII
M.kW	6.4	13.4	26.7
M.RPM	1950	2500	3150

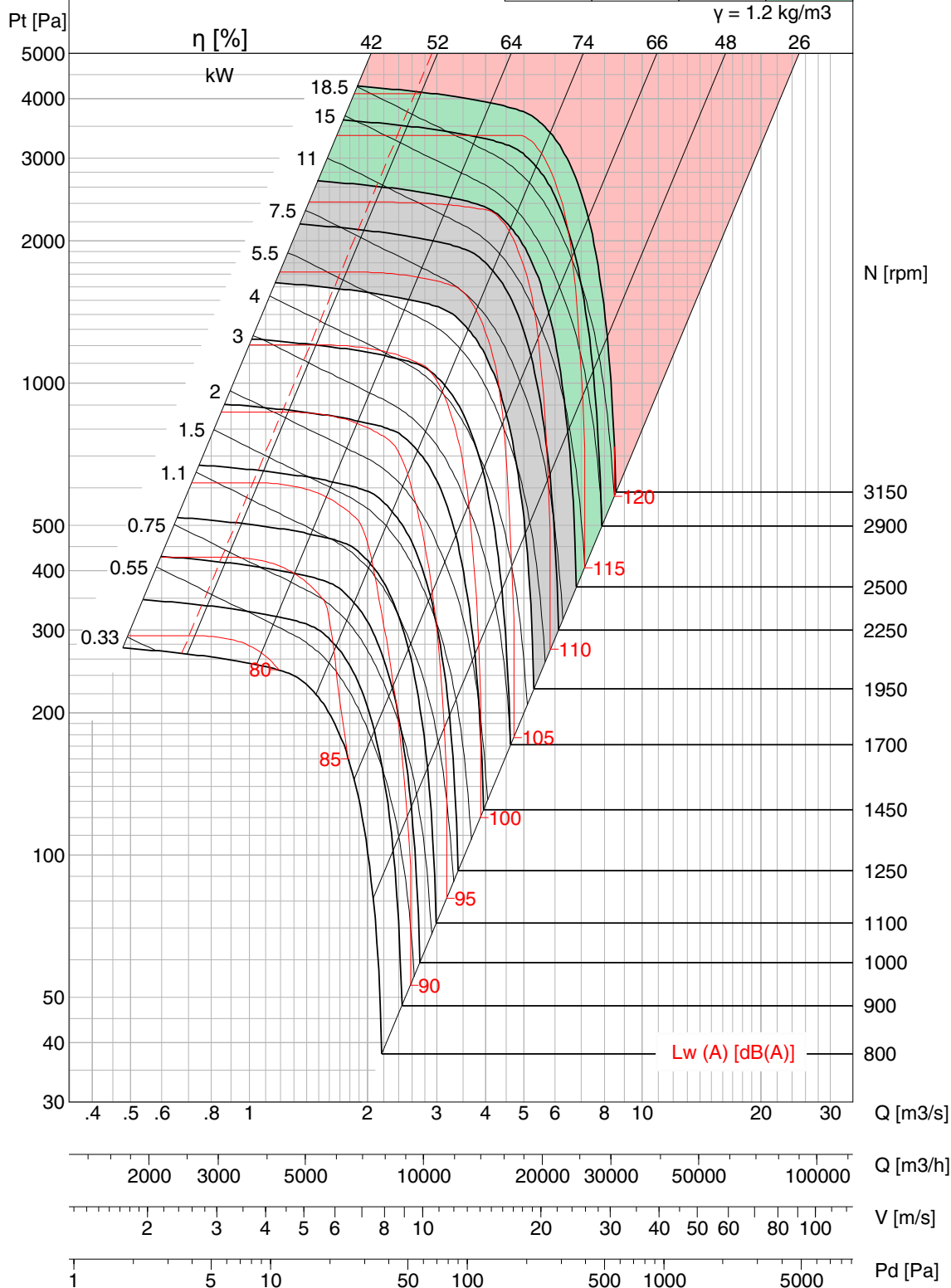

- Performance certified is for installation type A – free inlet, free outlet. Performance ratings do not include the effects of appurtenances (accessories). Power rating kW does not include transmission losses.
- Outlet Velocity of Model BNC is calculated in accordance with the fan outlet area as defined in AMCA 210 Annex H, Figure H.4.
- Values shown are for outlet Lwo A sound power levels for Installation Type A: free inlet, free outlet.
- The A-weighted sound ratings shown have been calculated per AMCA International Standard 301.
- Fan Efficiency Grade (FEG) is based on peak total efficiency in accordance with ISO 12759/ AMCA 205.
- Please consult Kruger for fan selection of class III.



BNC-R 560

FEG 80

Op Limit	Cl. I	Cl. II	Cl. III
Type	DI	DII	DIII
M.kW	7.1	15.6	31.5
M.RPM	1950	2540	3200

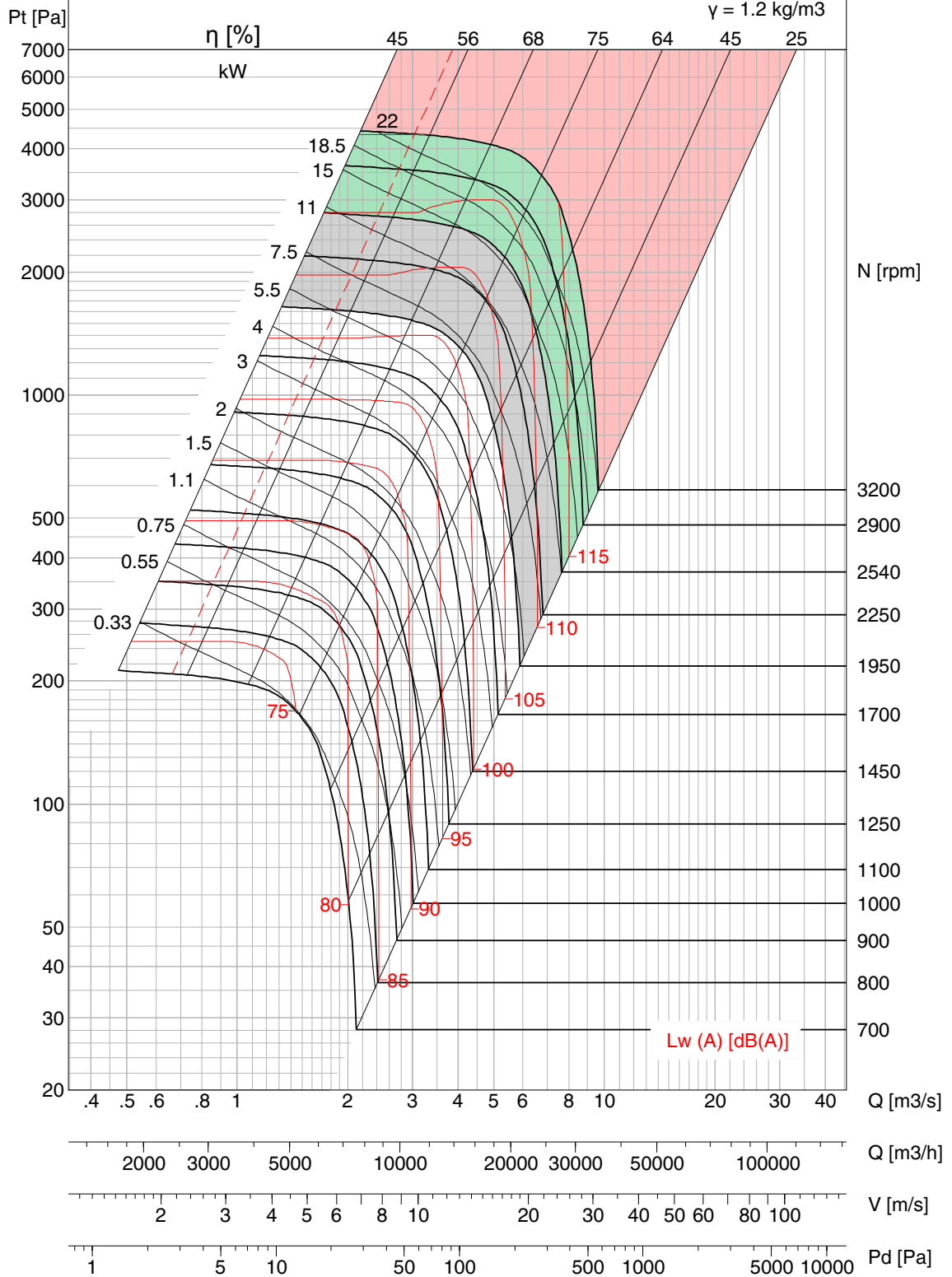

- Performance certified is for installation type A – free inlet, free outlet. Performance ratings do not include the effects of appurtenances (accessories). Power rating kW does not include transmission losses.
- Outlet Velocity of Model BNC is calculated in accordance with the fan outlet area as defined in AMCA 210 Annex H, Figure H.4.
- Values shown are for outlet Lwo A sound power levels for Installation Type A: free inlet, free outlet.
- The A-weighted sound ratings shown have been calculated per AMCA International Standard 301.
- Fan Efficiency Grade (FEG) is based on peak total efficiency in accordance with ISO 12759/ AMCA 205.
- Please consult Kruger for fan selection of class III.



BNC-Q 560

FEG 80

Op Limit	Cl. I	Cl. II	Cl. III
Type	DI	DII	DIII
M.kW	9	20.5	40.8
M.RPM	2050	2700	3400

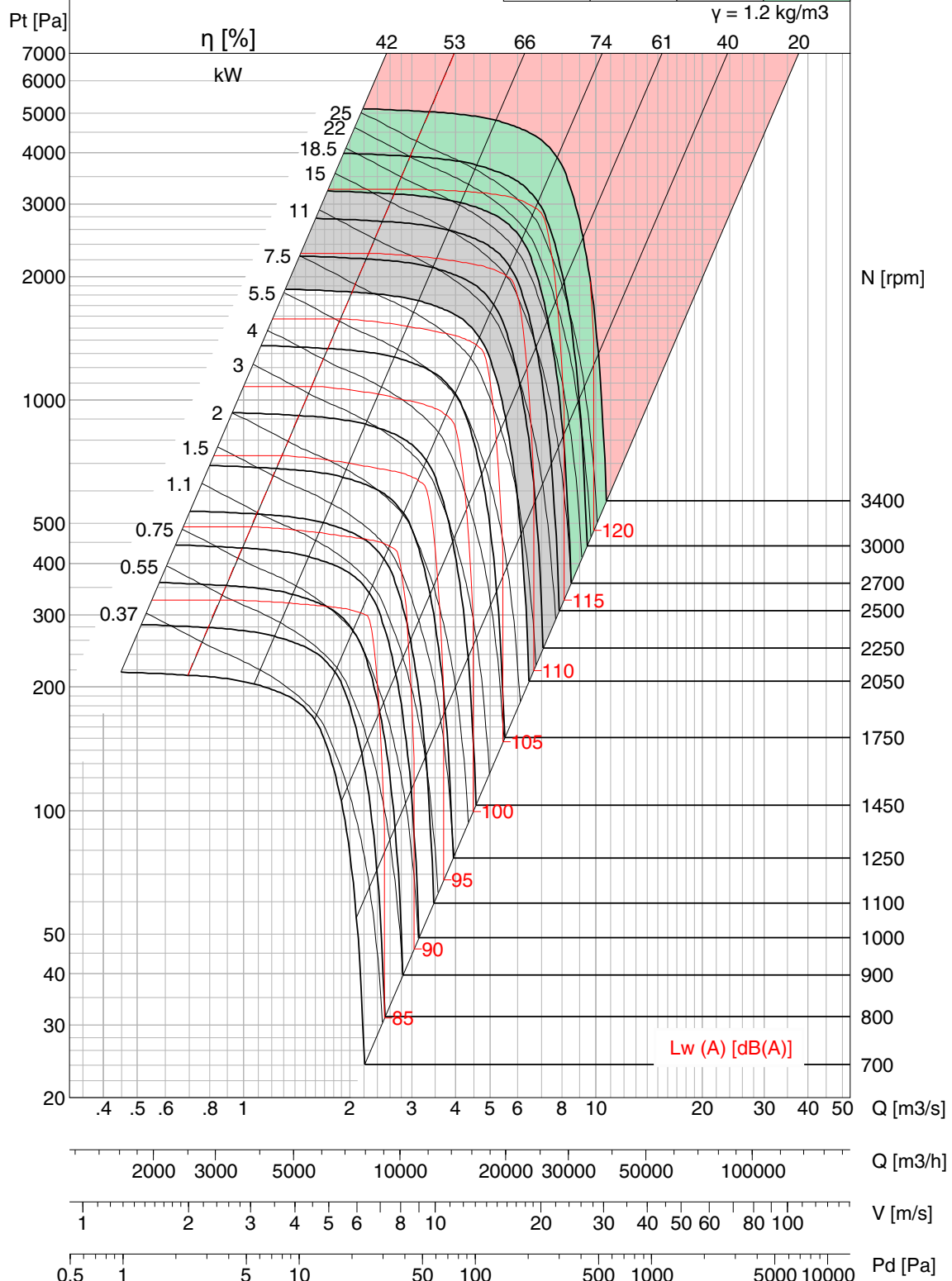

- Performance certified is for installation type A – free inlet, free outlet. Performance ratings do not include the effects of appurtenances (accessories).
- Power rating kW does not include transmission losses.
- Outlet Velocity of Model BNC is calculated in accordance with the fan outlet area as defined in AMCA 210 Annex H, Figure H.4.
- Values shown are for outlet Lwo A sound power levels for Installation Type A: free inlet, free outlet.
- The A-weighted sound ratings shown have been calculated per AMCA International Standard 301.
- Fan Efficiency Grade (FEG) is based on peak total efficiency in accordance with ISO 12759/ AMCA 205.
- Please consult Kruger for fan selection of class III.



BNC-P 630

FEG 80

Op Limit	Cl. I	Cl. II	Cl. III
Type	DI	DII	DIII
M.kW	7.4	16	33
M.RPM	1700	2200	2800

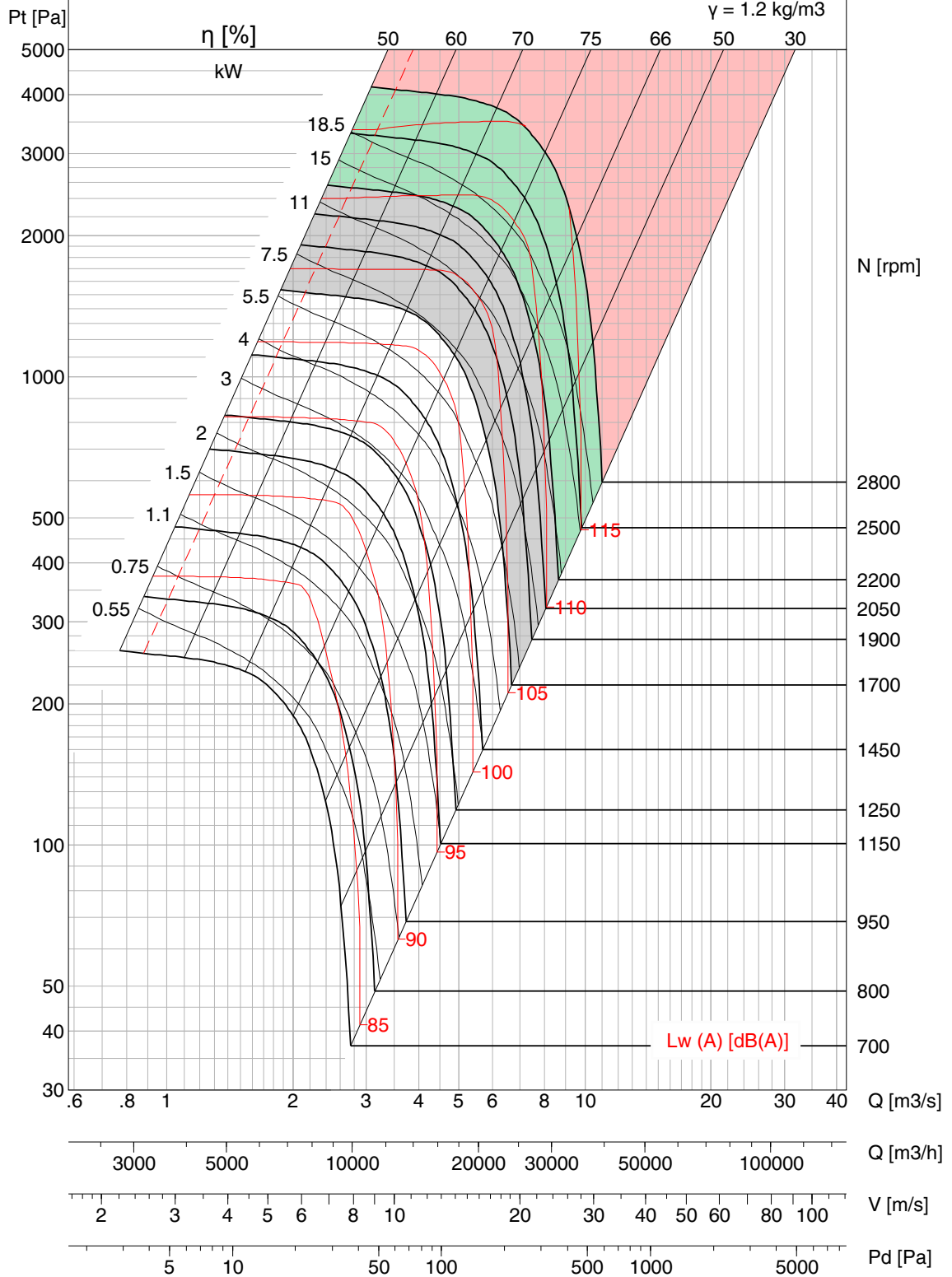

- Performance certified is for installation type A – free inlet, free outlet. Performance ratings do not include the effects of appurtenances (accessories). Power rating kW does not include transmission losses.
- Outlet Velocity of Model BNC is calculated in accordance with the fan outlet area as defined in AMCA 210 Annex H, Figure H.4.
- Values shown are for outlet Lwo A sound power levels for Installation Type A: free inlet, free outlet.
- The A-weighted sound ratings shown have been calculated per AMCA International Standard 301.
- Fan Efficiency Grade (FEG) is based on peak total efficiency in accordance with ISO 12759/ AMCA 205.
- Please consult Kruger for fan selection of class III.



BNC-R 630

FEG 80

Op Limit	Cl. I	Cl. II	Cl. III
Type	DI	DII	DIII
M.kW	9	19	38
M.RPM	1720	2230	2800

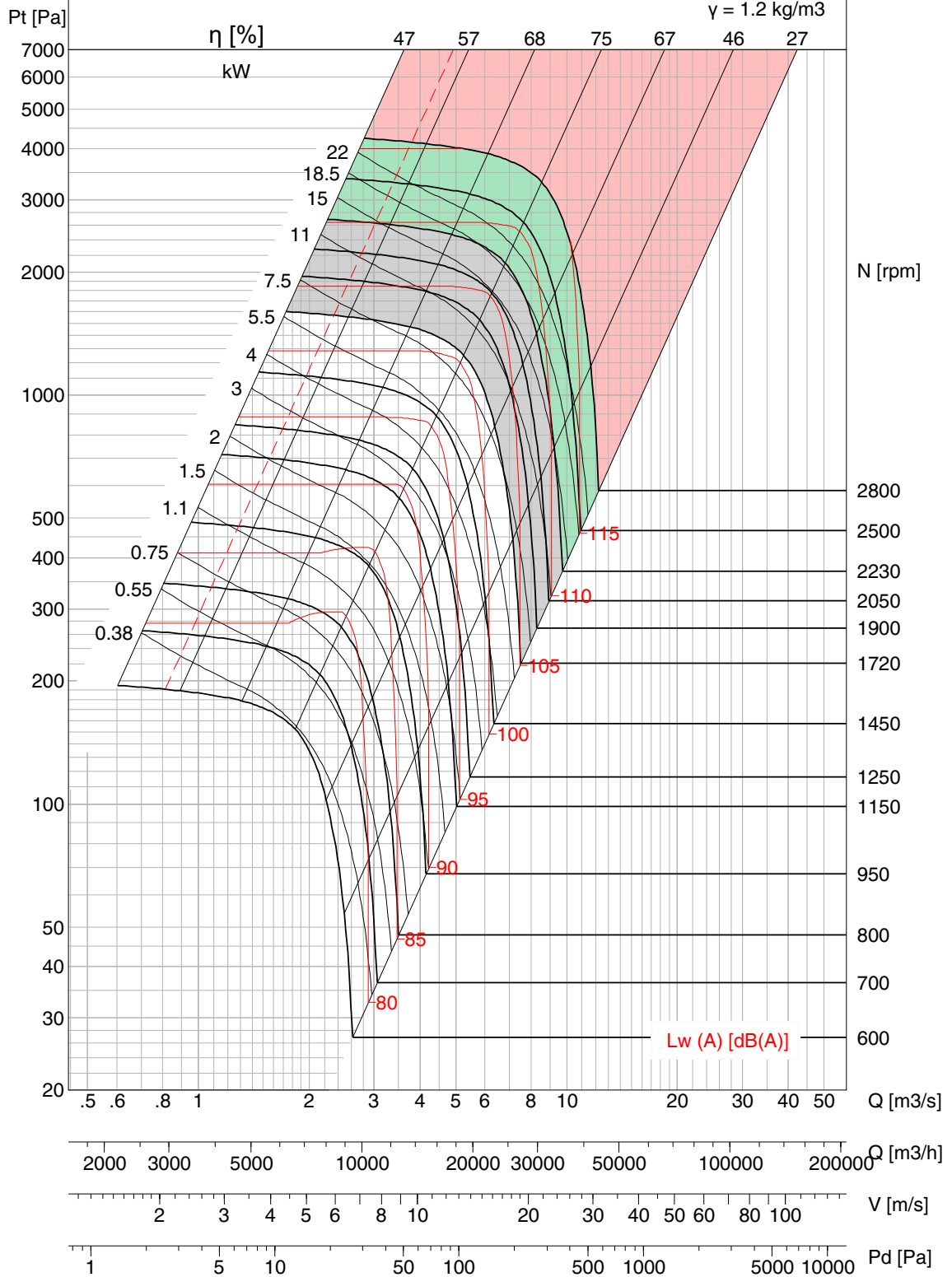

- Performance certified is for installation type A – free inlet, free outlet. Performance ratings do not include the effects of appurtenances (accessories).
- Power rating kW does not include transmission losses.
- Outlet Velocity of Model BNC is calculated in accordance with the fan outlet area as defined in AMCA 210 Annex H, Figure H.4.
- Values shown are for outlet Lwo A sound power levels for Installation Type A: free inlet, free outlet.
- The A-weighted sound ratings shown have been calculated per AMCA International Standard 301.
- Fan Efficiency Grade (FEG) is based on peak total efficiency in accordance with ISO 12759/ AMCA 205.
- Please consult Kruger for fan selection of class III.



BNC-Q 630

FEG 80

Op Limit	Cl. I	Cl. II	Cl. III
Type	DI	DII	DIII
M.kW	11	24	50
M.RPM	1800	2350	3000

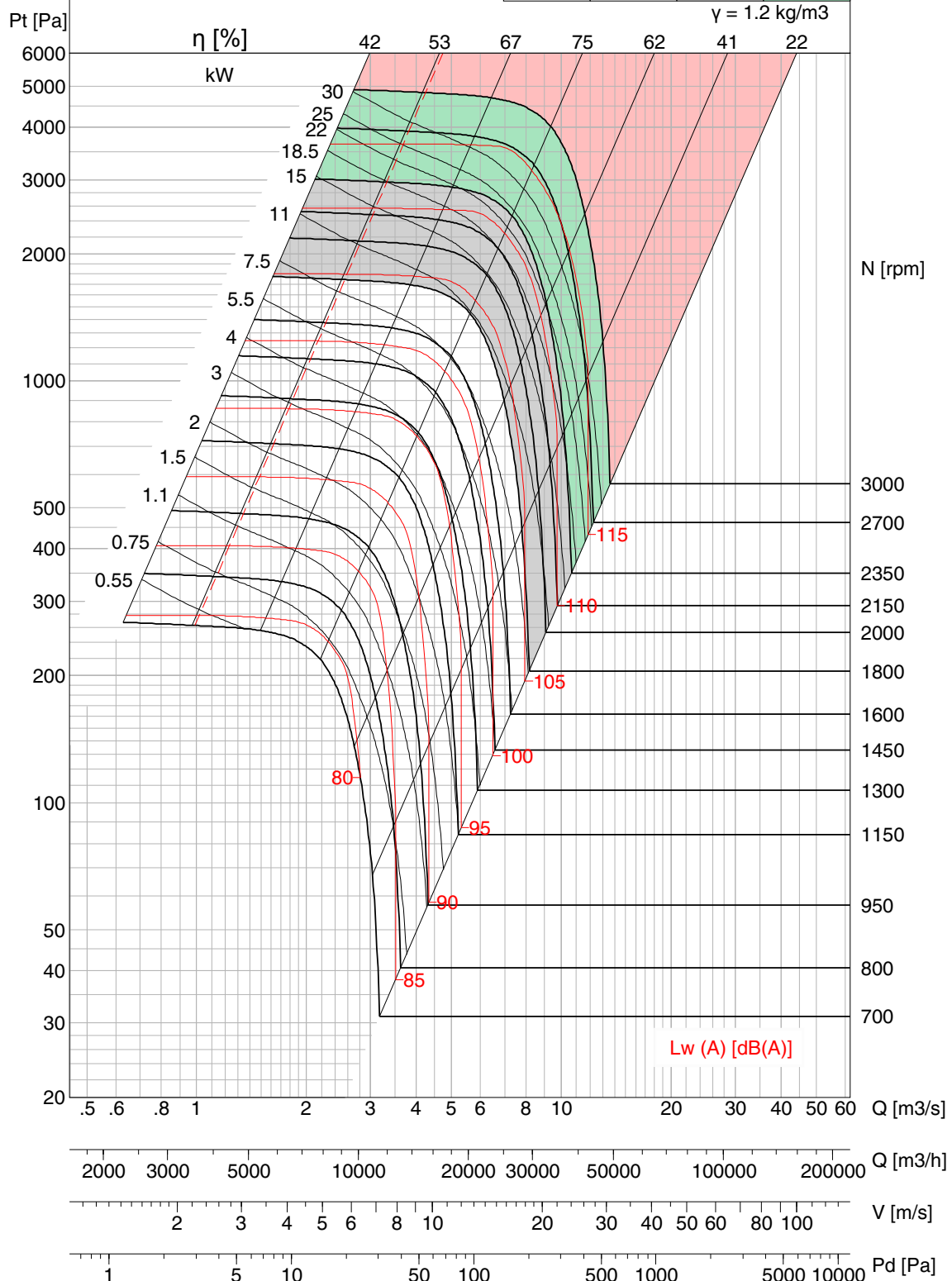

- Performance certified is for installation type A – free inlet, free outlet. Performance ratings do not include the effects of appurtenances (accessories). Power rating kW does not include transmission losses.
- Outlet Velocity of Model BNC is calculated in accordance with the fan outlet area as defined in AMCA 210 Annex H, Figure H.4.
- Values shown are for outlet Lwo A sound power levels for Installation Type A: free inlet, free outlet.
- The A-weighted sound ratings shown have been calculated per AMCA International Standard 301.
- Fan Efficiency Grade (FEG) is based on peak total efficiency in accordance with ISO 12759/ AMCA 205.
- Please consult Kruger for fan selection of class III.



BNC-P 710

FEG 80

Op Limit	Cl. I	Cl. II	Cl. III
Type	DI	DII	DIII
M.kW	9.7	21.3	42.3
M.RPM	1520	1980	2490

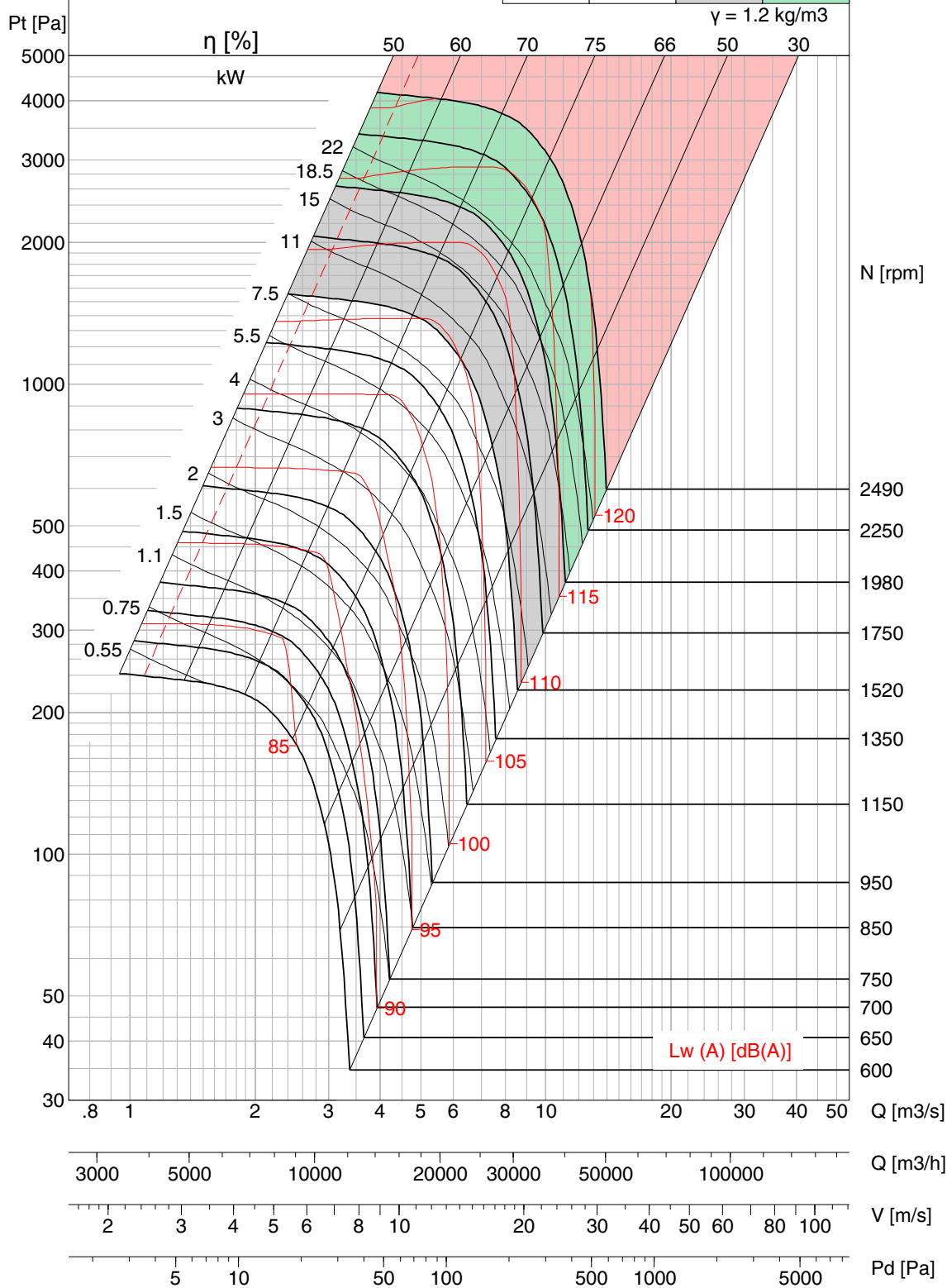

- Performance certified is for installation type A – free inlet, free outlet. Performance ratings do not include the effects of appurtenances (accessories). Power rating kW does not include transmission losses.
- Outlet Velocity of Model BNC is calculated in accordance with the fan outlet area as defined in AMCA 210 Annex H, Figure H.4.
- Values shown are for outlet Lwo A sound power levels for Installation Type A: free inlet, free outlet.
- The A-weighted sound ratings shown have been calculated per AMCA International Standard 301.
- Fan Efficiency Grade (FEG) is based on peak total efficiency in accordance with ISO 12759/ AMCA 205.
- Please consult Kruger for fan selection of class III.



BNC-R 710

FEG 80

Op Limit	Cl. I	Cl. II	Cl. III
Type	DI	DII	DIII
M.kW	11	25	49
M.RPM	1530	1990	2500

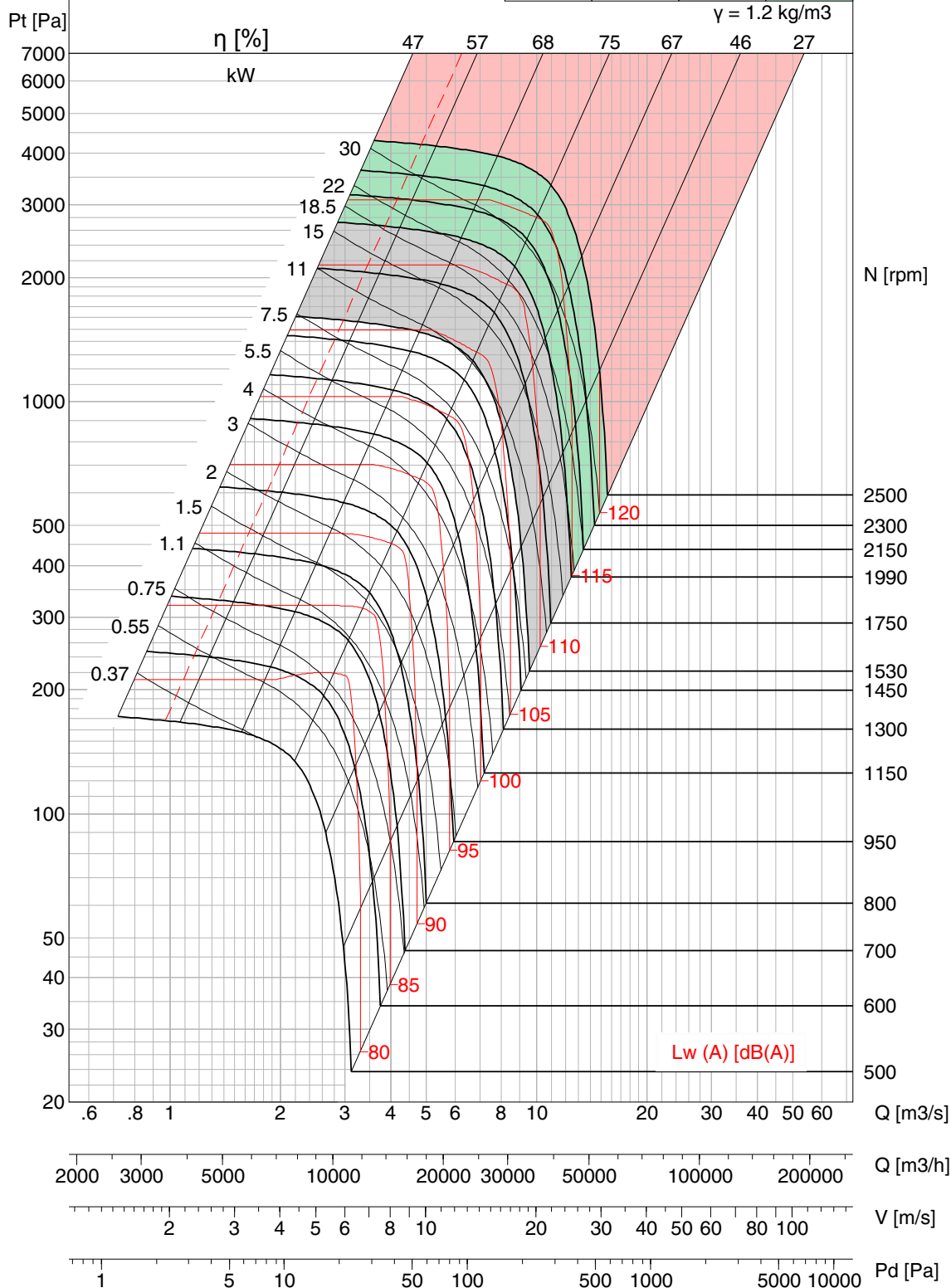

- Performance certified is for installation type A – free inlet, free outlet. Performance ratings do not include the effects of appurtenances (accessories).
- Power rating kW does not include transmission losses.
- Outlet Velocity of Model BNC is calculated in accordance with the fan outlet area as defined in AMCA 210 Annex H, Figure H.4.
- Values shown are for outlet Lwo A sound power levels for Installation Type A: free inlet, free outlet.
- The A-weighted sound ratings shown have been calculated per AMCA International Standard 301.
- Fan Efficiency Grade (FEG) is based on peak total efficiency in accordance with ISO 12759/ AMCA 205.
- Please consult Kruger for fan selection of class III.



BNC-Q 710

FEG 80

Op Limit	Cl. I	Cl. II	Cl. III
Type	DI	DII	DIII
M.kW	13.8	31.2	62.7
M.RPM	1600	2100	2650

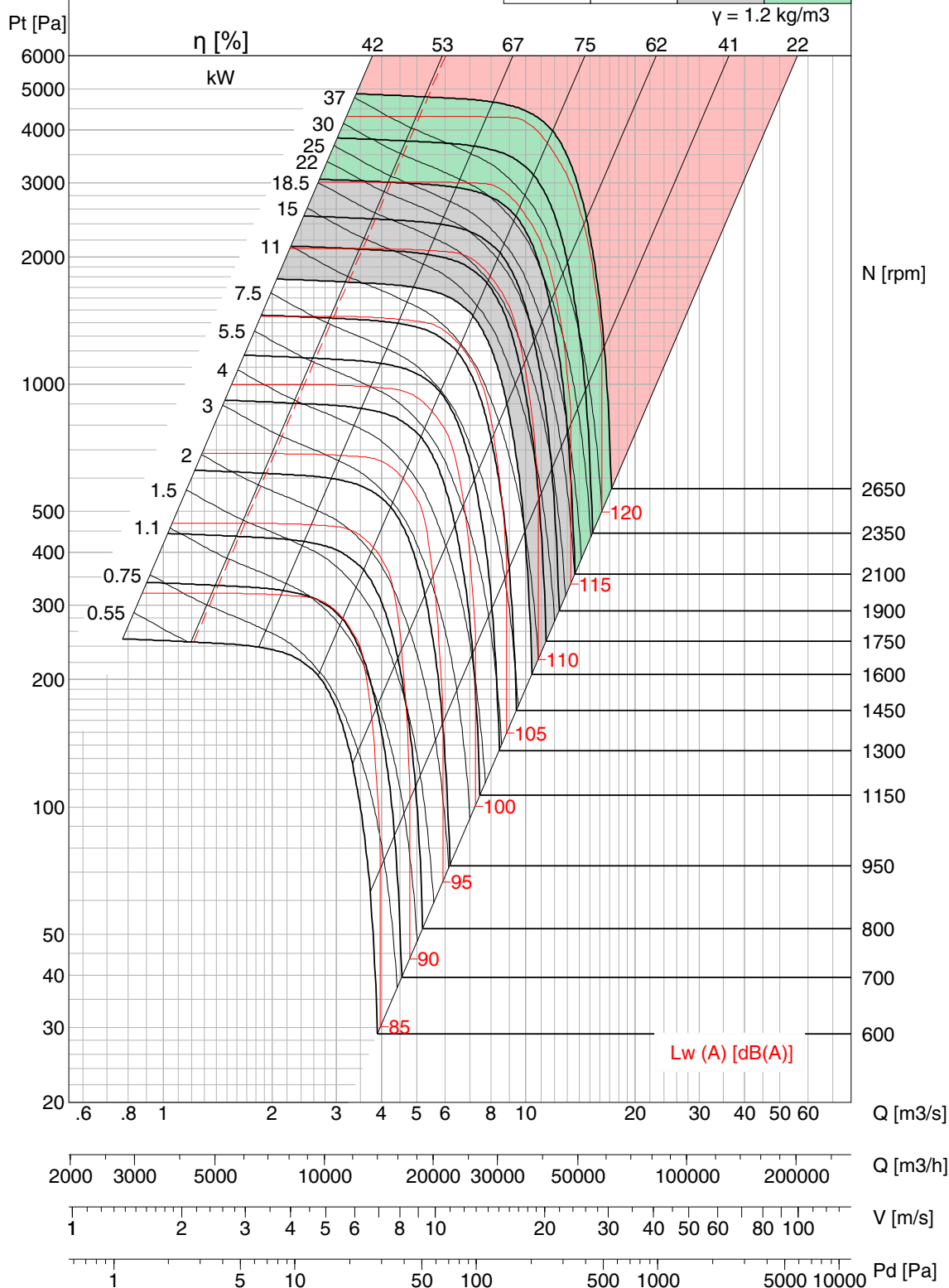

- Performance certified is for installation type A – free inlet, free outlet. Performance ratings do not include the effects of appurtenances (accessories).
- Power rating kW does not include transmission losses.
- Outlet Velocity of Model BNC is calculated in accordance with the fan outlet area as defined in AMCA 210 Annex H, Figure H.4.
- Values shown are for outlet Lwo A sound power levels for Installation Type A: free inlet, free outlet.
- The A-weighted sound ratings shown have been calculated per AMCA International Standard 301.
- Fan Efficiency Grade (FEG) is based on peak total efficiency in accordance with ISO 12759/ AMCA 205.
- Please consult Kruger for fan selection of class III.



BNC-P 800

FEG 80

Op Limit	Cl. I	Cl. II	Cl. III
Type	DI	DII	DIII
M.kW	12.3	26.7	53
M.RPM	1350	1750	2200

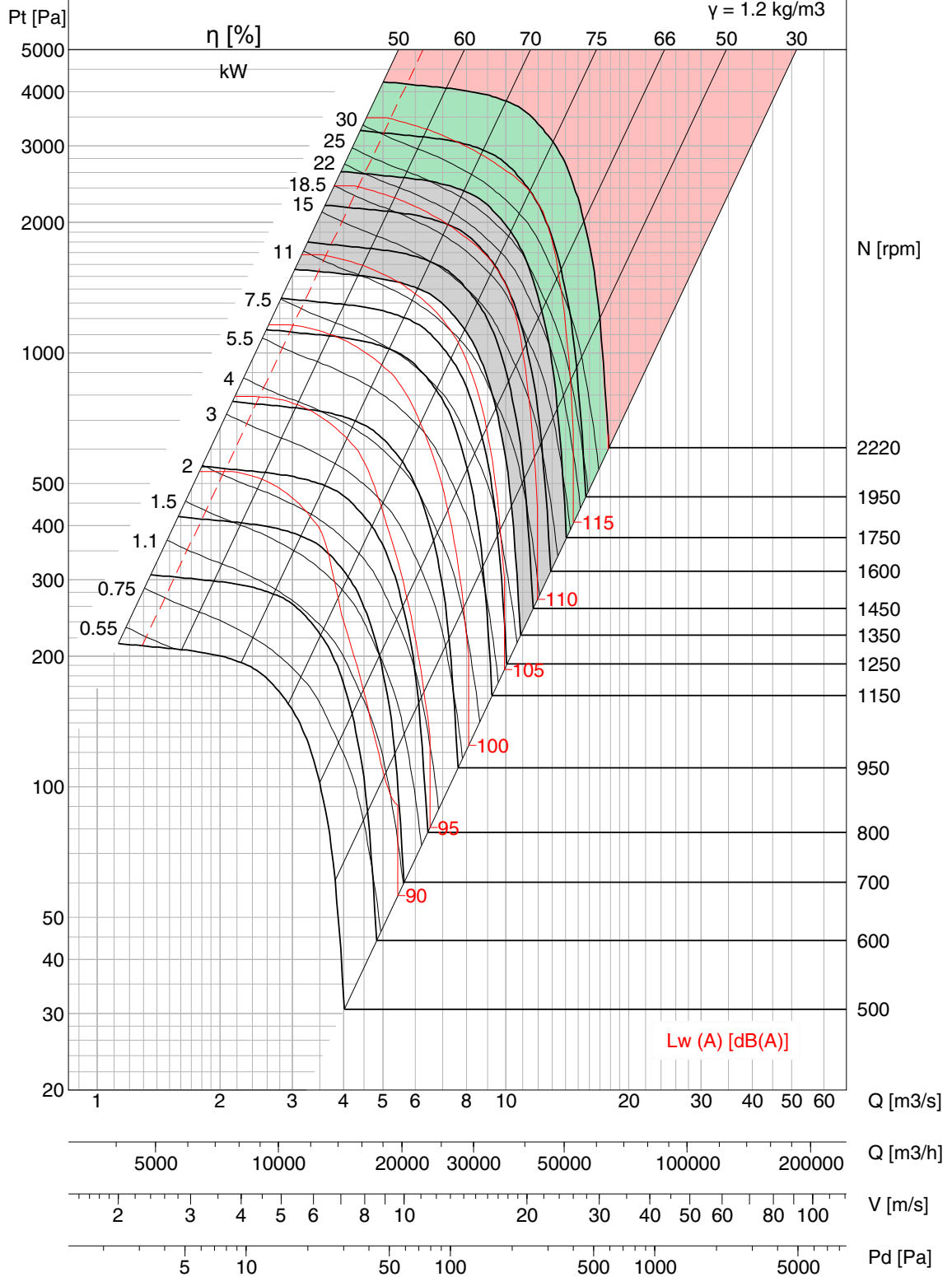

- Performance certified is for installation type A – free inlet, free outlet. Performance ratings do not include the effects of appurtenances (accessories). Power rating kW does not include transmission losses.
- Outlet Velocity of Model BNC is calculated in accordance with the fan outlet area as defined in AMCA 210 Annex H, Figure H.4.
- Values shown are for outlet Lwo A sound power levels for Installation Type A: free inlet, free outlet.
- The A-weighted sound ratings shown have been calculated per AMCA International Standard 301.
- Fan Efficiency Grade (FEG) is based on peak total efficiency in accordance with ISO 12759/ AMCA 205.
- Please consult Kruger for fan selection of class III.



BNC-R 800

FEG 80

Op Limit	Cl. I	Cl. II	Cl. III
Type	DI	DII	DIII
M.kW	14.6	31.5	62
M.RPM	1370	1770	2220

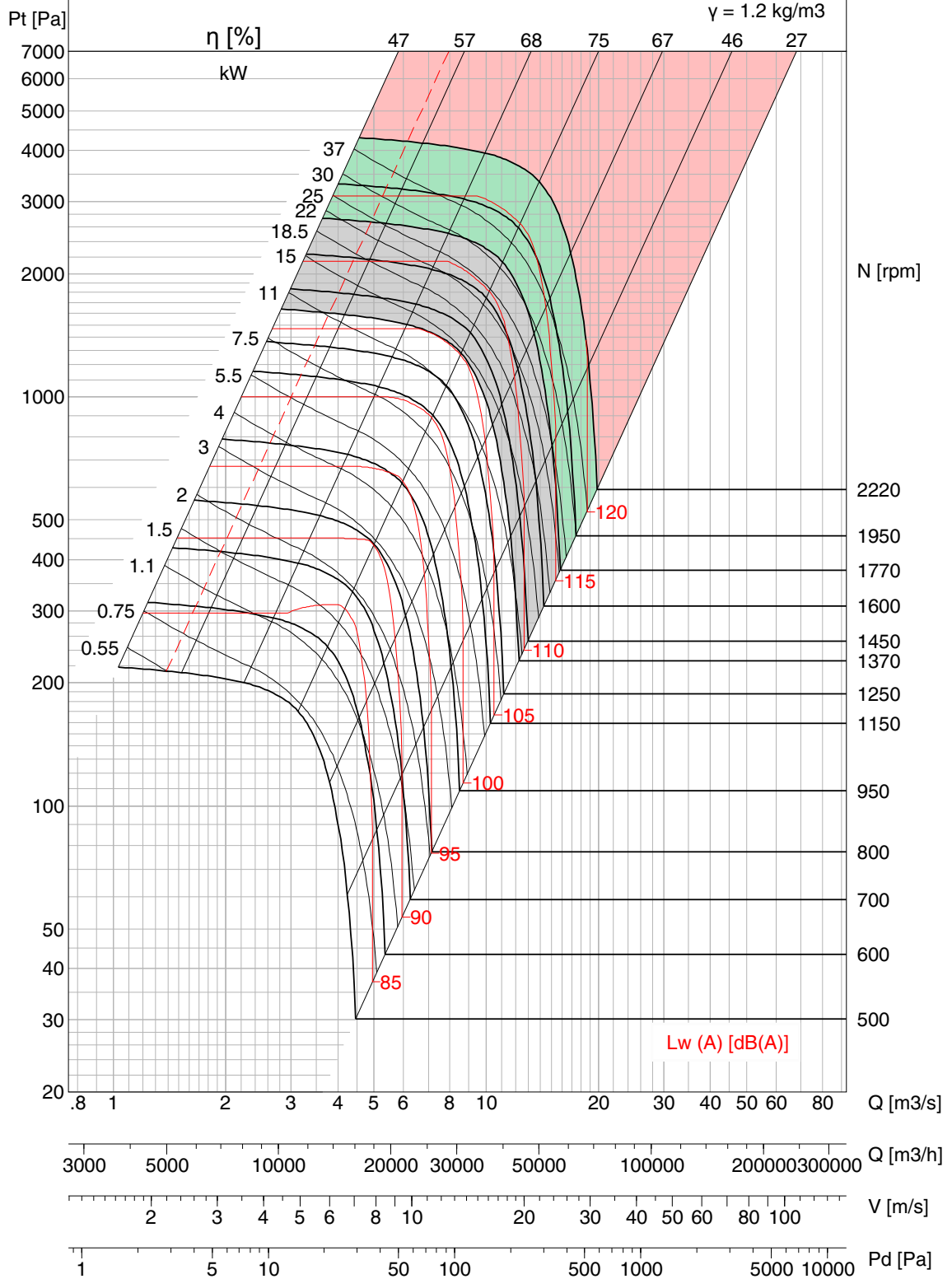

- Performance certified is for installation type A – free inlet, free outlet. Performance ratings do not include the effects of appurtenances (accessories).
- Power rating kW does not include transmission losses.
- Outlet Velocity of Model BNC is calculated in accordance with the fan outlet area as defined in AMCA 210 Annex H, Figure H.4.
- Values shown are for outlet Lwo A sound power levels for Installation Type A: free inlet, free outlet.
- The A-weighted sound ratings shown have been calculated per AMCA International Standard 301.
- Fan Efficiency Grade (FEG) is based on peak total efficiency in accordance with ISO 12759/ AMCA 205.
- Please consult Kruger for fan selection of class III.



BNC-Q 800

FEG 80

Op Limit	Cl. I	Cl. II	Cl. III
Type	DI	DII	DIII
M.kW	18.7	38.8	79.4
M.RPM	1450	1850	2350

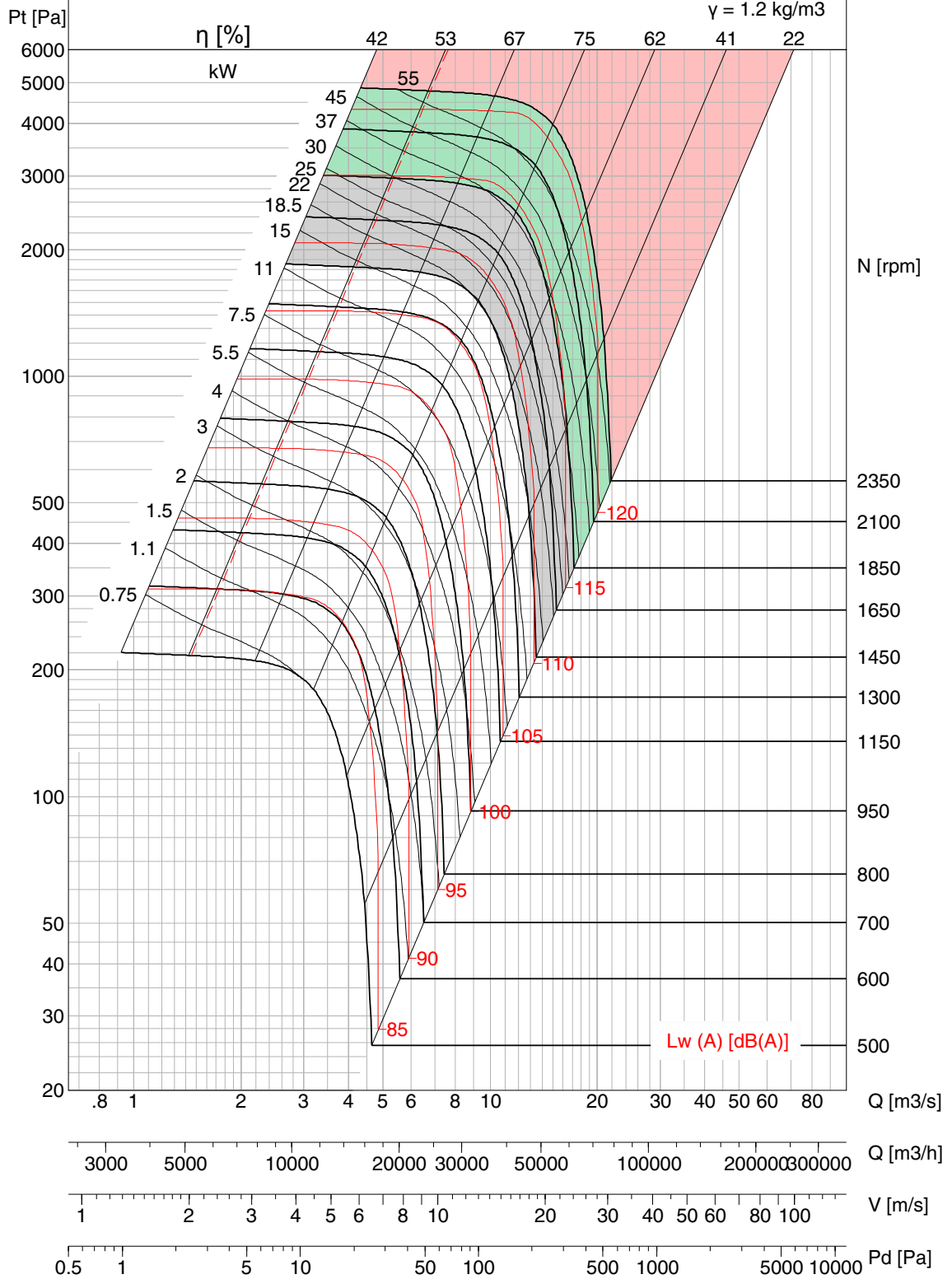

- Performance certified is for installation type A – free inlet, free outlet. Performance ratings do not include the effects of appurtenances (accessories).
- Power rating kW does not include transmission losses.
- Outlet Velocity of Model BNC is calculated in accordance with the fan outlet area as defined in AMCA 210 Annex H, Figure H.4.
- Values shown are for outlet Lwo A sound power levels for Installation Type A: free inlet, free outlet.
- The A-weighted sound ratings shown have been calculated per AMCA International Standard 301.
- Fan Efficiency Grade (FEG) is based on peak total efficiency in accordance with ISO 12759/ AMCA 205.
- Please consult Kruger for fan selection of class III.



BNC-P 900

FEG 80

Op Limit	Cl. I	Cl. II	Cl. III
Type	DI	DII	DIII
M.kW	15.3	33.5	67.4
M.RPM	1170	1520	1920

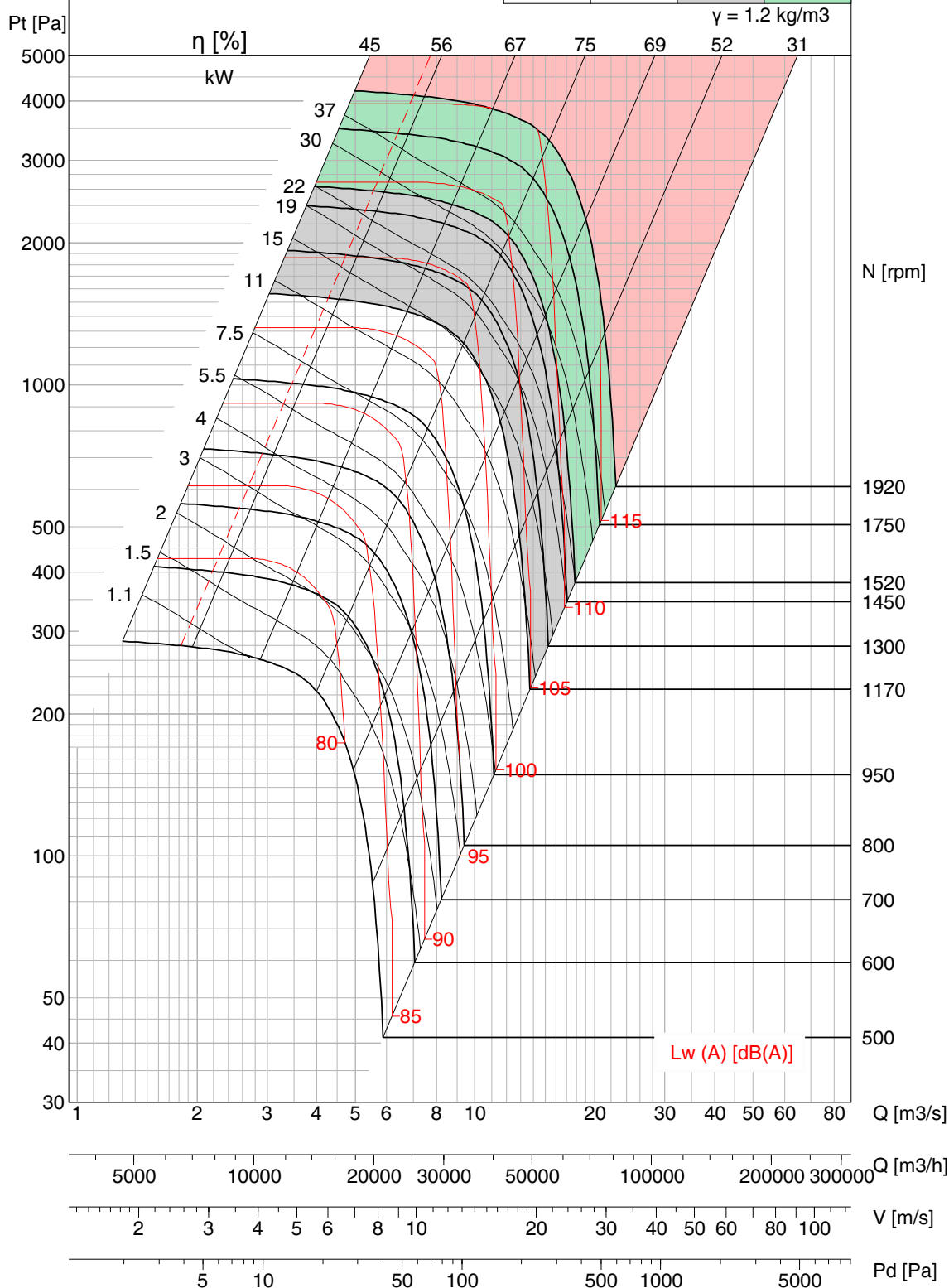

- Performance certified is for installation type A – free inlet, free outlet. Performance ratings do not include the effects of appurtenances (accessories). Power rating kW does not include transmission losses.
- Outlet Velocity of Model BNC is calculated in accordance with the fan outlet area as defined in AMCA 210 Annex H, Figure H.4.
- Values shown are for outlet Lwo A sound power levels for Installation Type A: free inlet, free outlet.
- The A-weighted sound ratings shown have been calculated per AMCA International Standard 301.
- Fan Efficiency Grade (FEG) is based on peak total efficiency in accordance with ISO 12759/ AMCA 205.
- Please consult Kruger for fan selection of class III.



BNC-R 900

FEG 80

Op Limit	Cl. I	Cl. II	Cl. III
Type	DI	DII	DIII
M.kW	18	39	78
M.RPM	1210	1570	1980

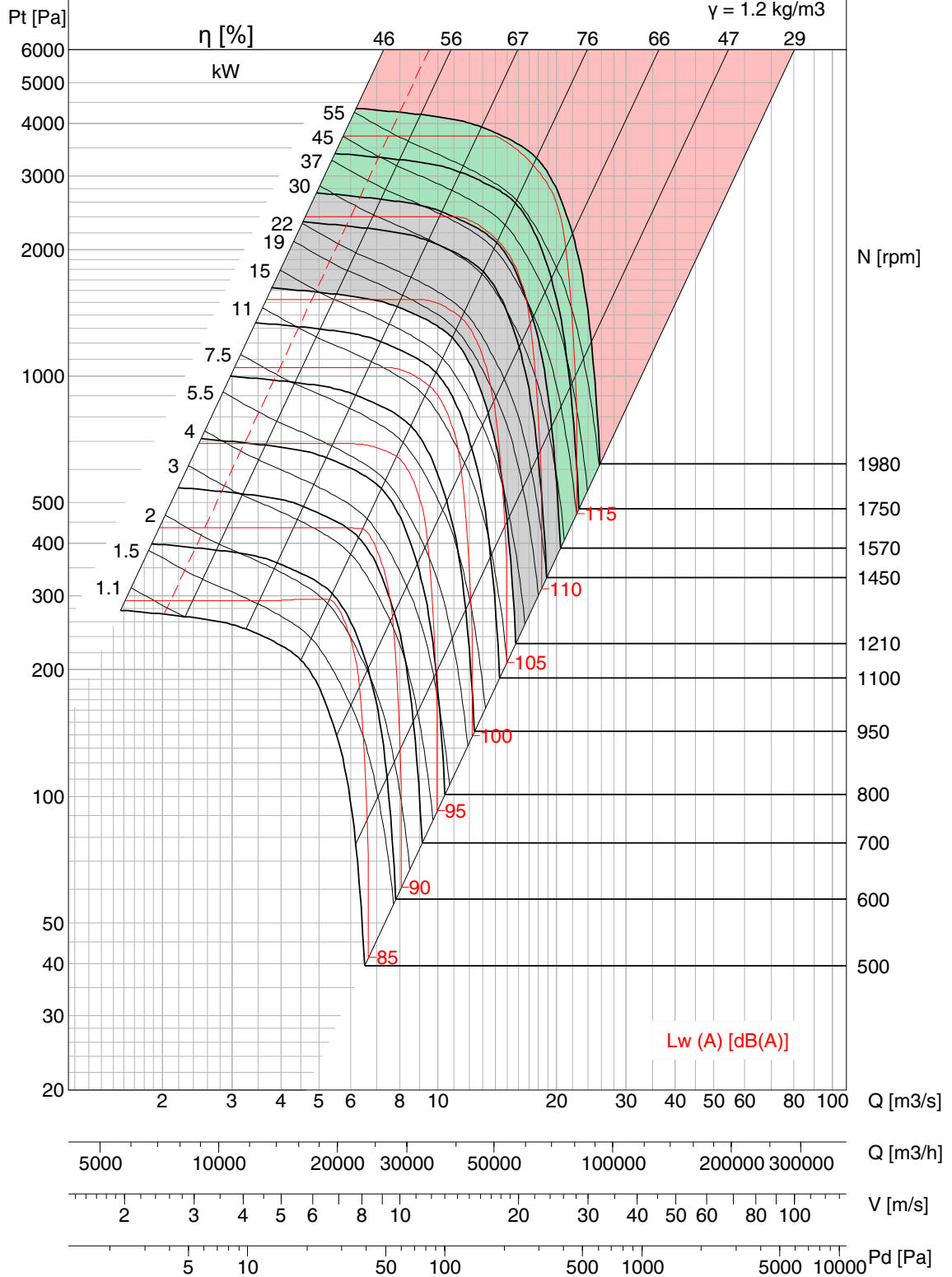

- Performance certified is for installation type A – free inlet, free outlet. Performance ratings do not include the effects of appurtenances (accessories).
- Power rating kW does not include transmission losses.
- Outlet Velocity of Model BNC is calculated in accordance with the fan outlet area as defined in AMCA 210 Annex H, Figure H.4.
- Values shown are for outlet Lwo A sound power levels for Installation Type A: free inlet, free outlet.
- The A-weighted sound ratings shown have been calculated per AMCA International Standard 301.
- Fan Efficiency Grade (FEG) is based on peak total efficiency in accordance with ISO 12759/ AMCA 205.
- Please consult Kruger for fan selection of class III.



BNC-Q 900

FEG 80

Op Limit	Cl. I	Cl. II	Cl. III
Type	DI	DII	DIII
M.kW	22.2	46.5	97.7
M.RPM	1250	1600	2050

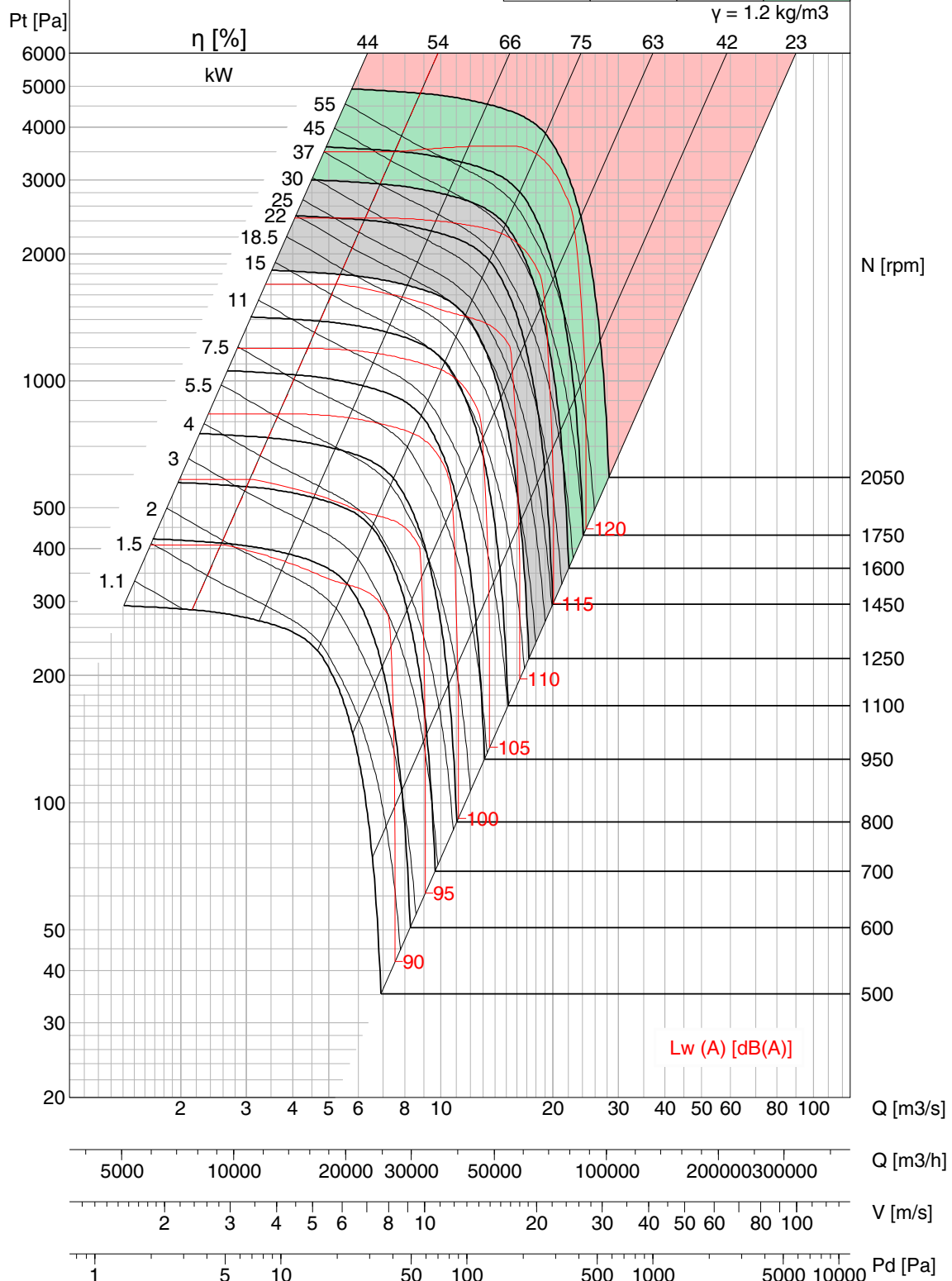

- Performance certified is for installation type A – free inlet, free outlet. Performance ratings do not include the effects of appurtenances (accessories).
- Power rating kW does not include transmission losses.
- Outlet Velocity of Model BNC is calculated in accordance with the fan outlet area as defined in AMCA 210 Annex H, Figure H.4.
- Values shown are for outlet Lwo A sound power levels for Installation Type A: free inlet, free outlet.
- The A-weighted sound ratings shown have been calculated per AMCA International Standard 301.
- Fan Efficiency Grade (FEG) is based on peak total efficiency in accordance with ISO 12759/ AMCA 205.
- Please consult Kruger for fan selection of class III.



BNC-P 1000

FEG 80

Op Limit	Cl. I	Cl. II	Cl. III
Type	DI	DII	DIII
M.kW	19.3	42.4	86.5
M.RPM	1060	1380	1750

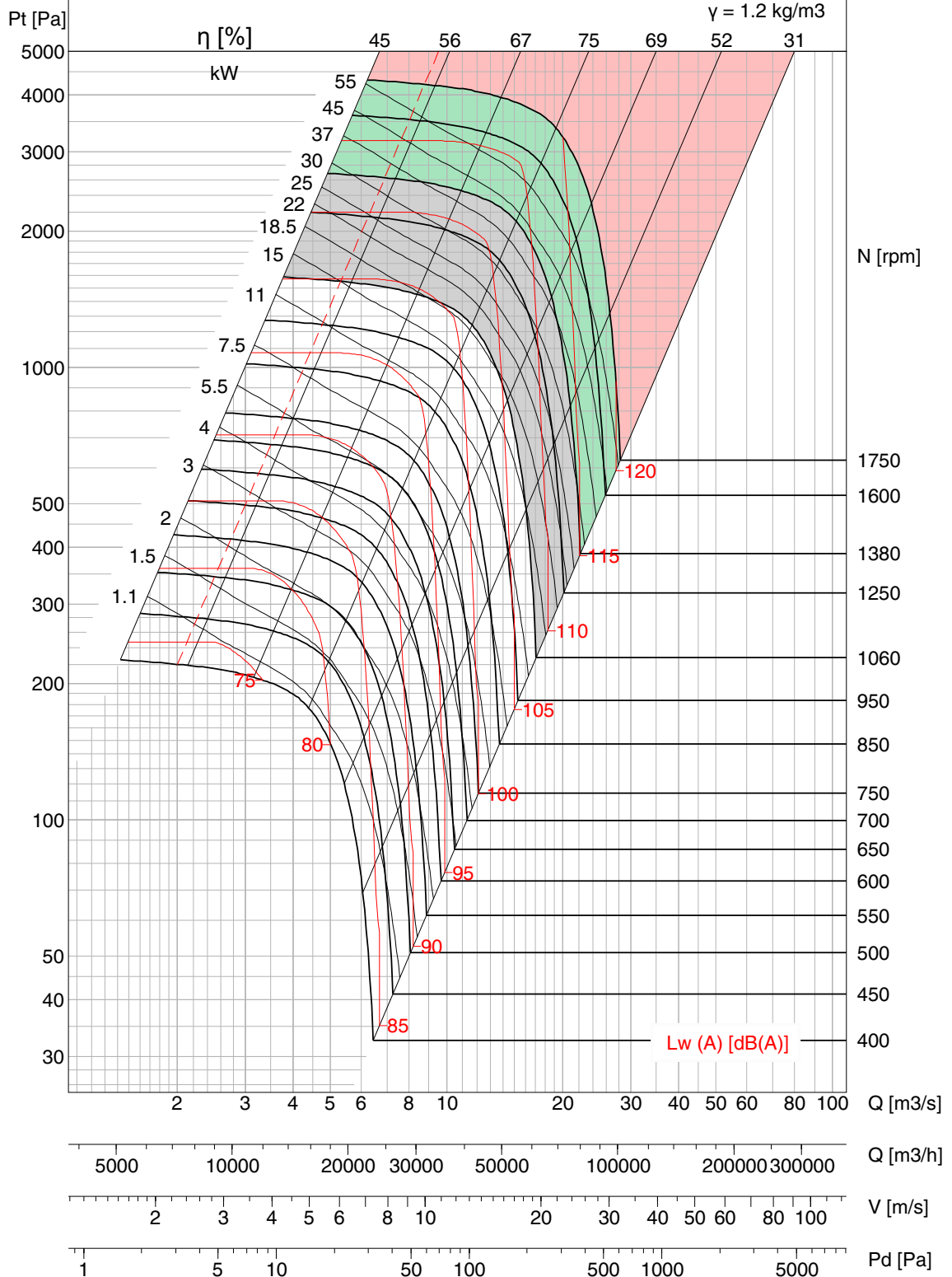

- Performance certified is for installation type A – free inlet, free outlet. Performance ratings do not include the effects of appurtenances (accessories). Power rating kW does not include transmission losses.
- Outlet Velocity of Model BNC is calculated in accordance with the fan outlet area as defined in AMCA 210 Annex H, Figure H.4.
- Values shown are for outlet Lwo A sound power levels for Installation Type A: free inlet, free outlet.
- The A-weighted sound ratings shown have been calculated per AMCA International Standard 301.
- Fan Efficiency Grade (FEG) is based on peak total efficiency in accordance with ISO 12759/ AMCA 205.
- Please consult Kruger for fan selection of class III.



BNC-R 1000

FEG 80

Op Limit	Cl. I	Cl. II	Cl. III
Type	DI	DII	DIII
M.kW	21.4	47	94
M.RPM	1080	1400	1770

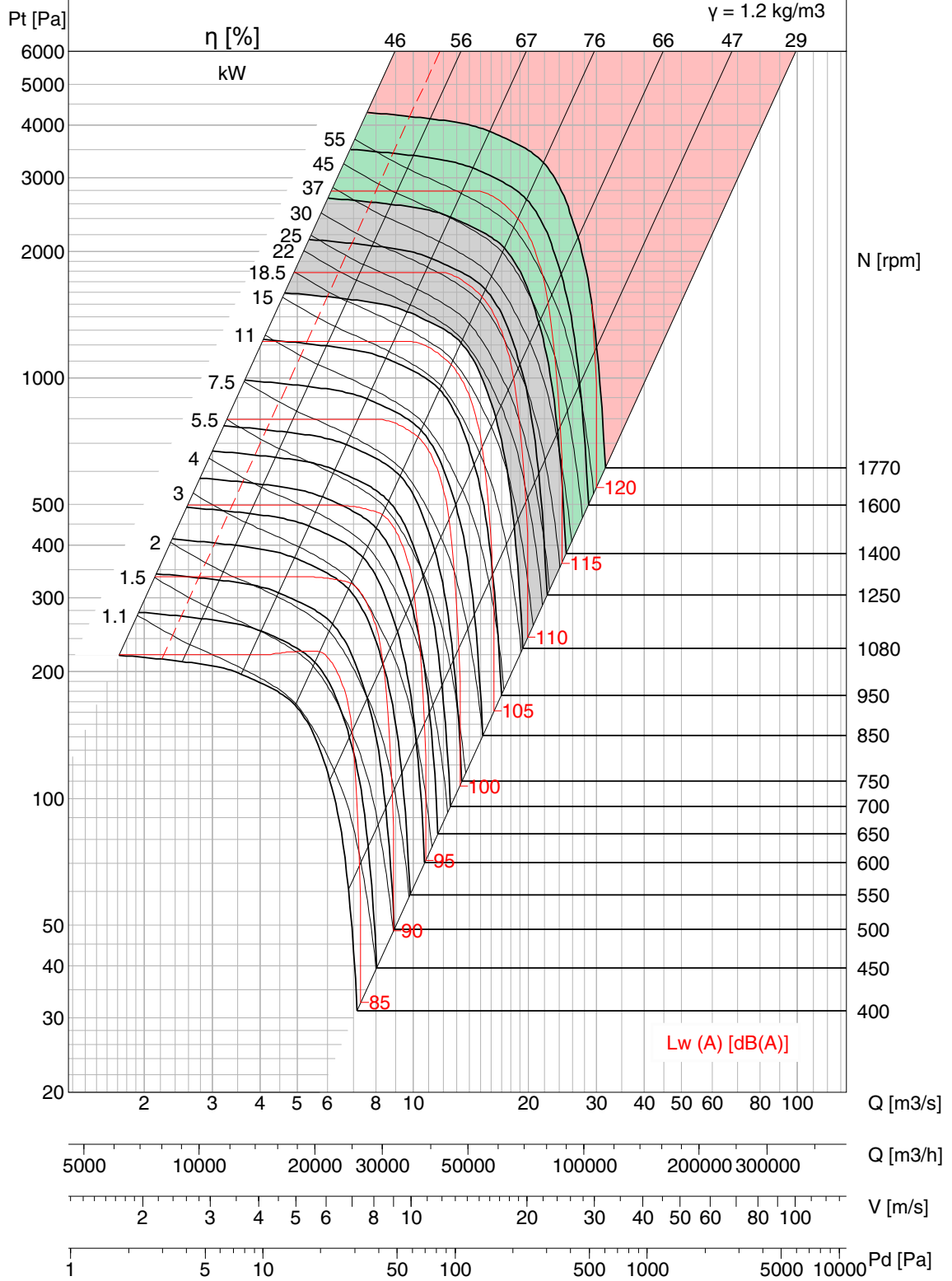

- Performance certified is for installation type A – free inlet, free outlet. Performance ratings do not include the effects of appurtenances (accessories). Power rating kW does not include transmission losses.
- Outlet Velocity of Model BNC is calculated in accordance with the fan outlet area as defined in AMCA 210 Annex H, Figure H.4.
- Values shown are for outlet Lwo A sound power levels for Installation Type A: free inlet, free outlet.
- The A-weighted sound ratings shown have been calculated per AMCA International Standard 301.
- Fan Efficiency Grade (FEG) is based on peak total efficiency in accordance with ISO 12759/ AMCA 205.
- Please consult Kruger for fan selection of class III.



BNC-Q 1000

FEG 80

Op Limit	Cl. I	Cl. II	Cl. III
Type	DI	DII	DIII
M.kW	27	59	122
M.RPM	1120	1450	1850

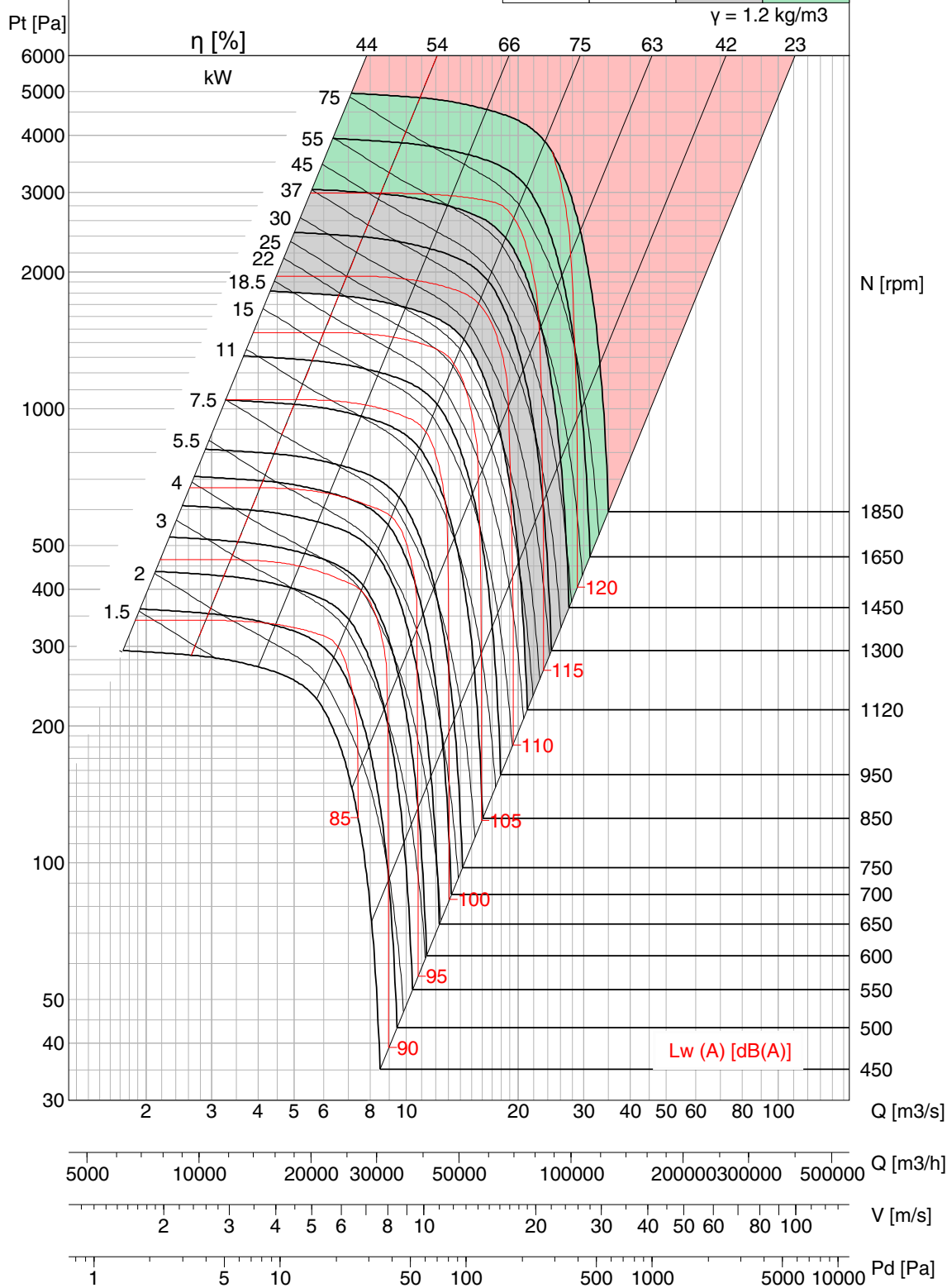

- Performance certified is for installation type A – free inlet, free outlet. Performance ratings do not include the effects of appurtenances (accessories). Power rating kW does not include transmission losses.
- Outlet Velocity of Model BNC is calculated in accordance with the fan outlet area as defined in AMCA 210 Annex H, Figure H.4.
- Values shown are for outlet Lwo A sound power levels for Installation Type A: free inlet, free outlet.
- The A-weighted sound ratings shown have been calculated per AMCA International Standard 301.
- Fan Efficiency Grade (FEG) is based on peak total efficiency in accordance with ISO 12759/ AMCA 205.
- Please consult Kruger for fan selection of class III.



BNC-P 1120

FEG 80

Op Limit	Cl. I	Cl. II	Cl. III
Type	DI	DII	DIII
M.kW	24.5	53	106
M.RPM	950	1230	1550

$\gamma = 1.2 \text{ kg/m}^3$

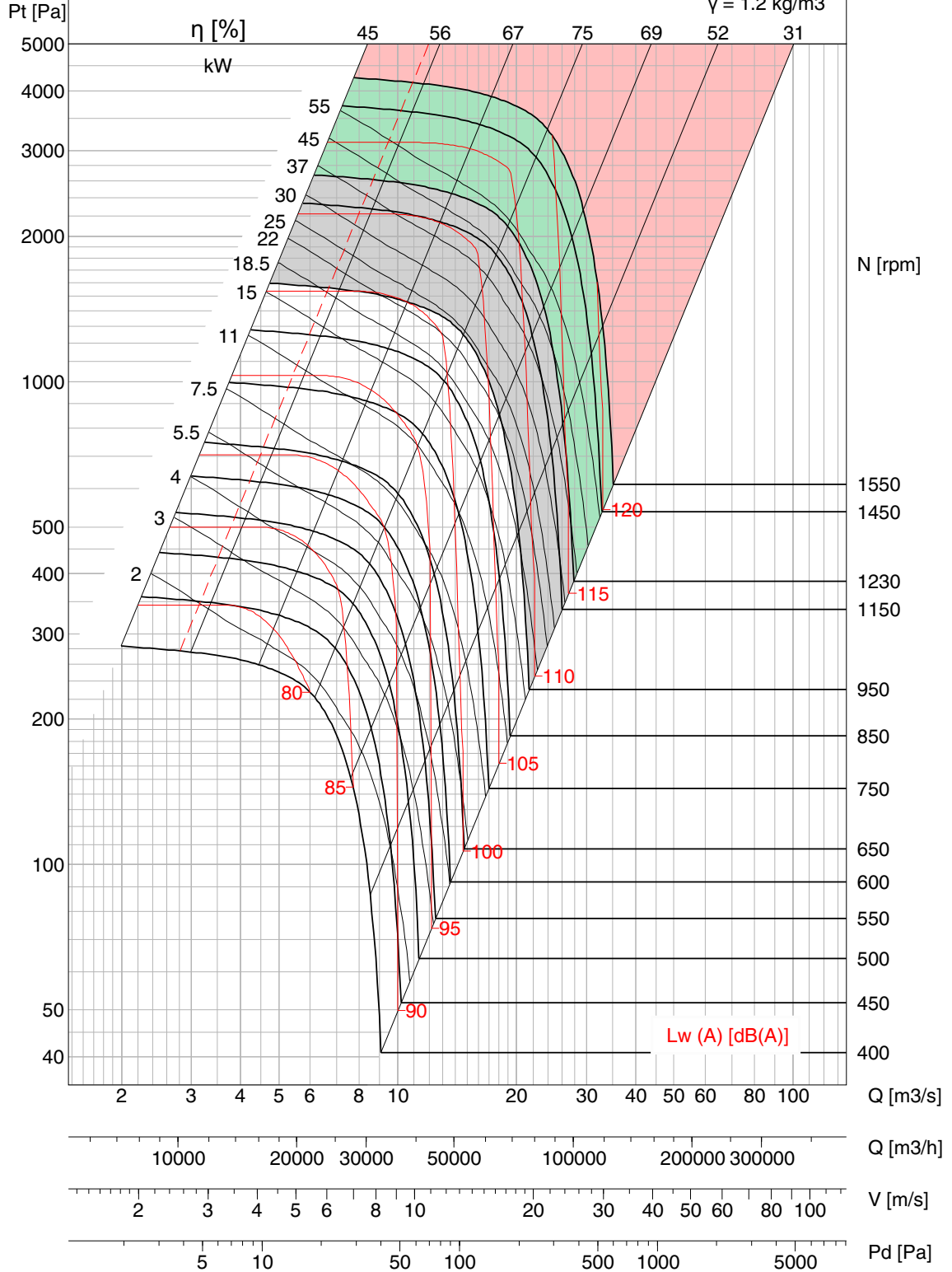

- Performance certified is for installation type A – free inlet, free outlet. Performance ratings do not include the effects of appurtenances (accessories). Power rating kW does not include transmission losses.
- Outlet Velocity of Model BNC is calculated in accordance with the fan outlet area as defined in AMCA 210 Annex H, Figure H.4.
- Values shown are for outlet Lwo A sound power levels for Installation Type A: free inlet, free outlet.
- The A-weighted sound ratings shown have been calculated per AMCA International Standard 301.
- Fan Efficiency Grade (FEG) is based on peak total efficiency in accordance with ISO 12759/ AMCA 205.
- Please consult Kruger for fan selection of class III.



BNC-R 1120

FEG 80

Op Limit	Cl. I	Cl. II	Cl. III
Type	DI	DII	DIII
M.kW	27.5	58.5	118
M.RPM	970	1250	1580

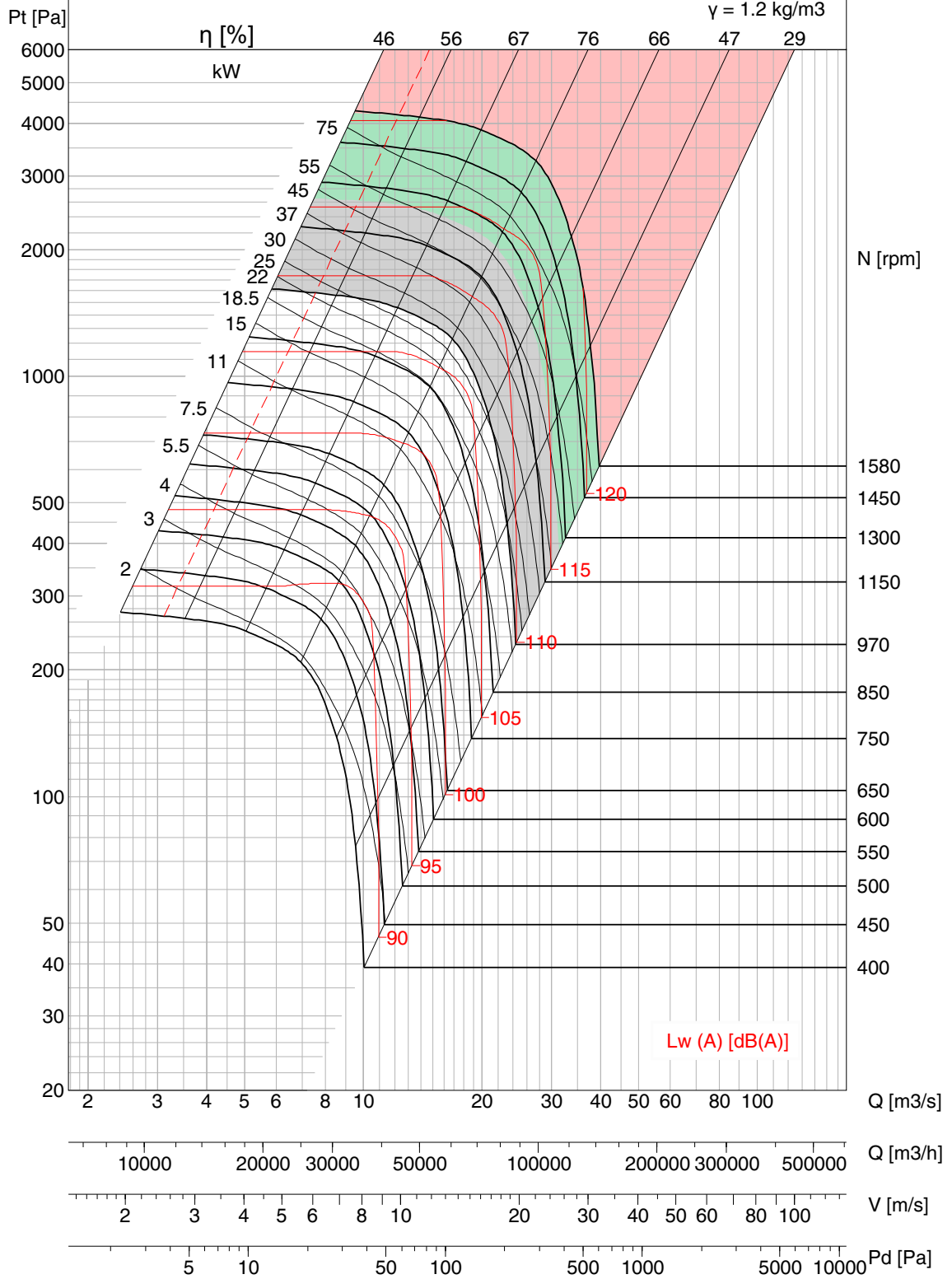

- Performance certified is for installation type A – free inlet, free outlet. Performance ratings do not include the effects of appurtenances (accessories).
- Power rating kW does not include transmission losses.
- Outlet Velocity of Model BNC is calculated in accordance with the fan outlet area as defined in AMCA 210 Annex H, Figure H.4.
- Values shown are for outlet Lwo A sound power levels for Installation Type A: free inlet, free outlet.
- The A-weighted sound ratings shown have been calculated per AMCA International Standard 301.
- Fan Efficiency Grade (FEG) is based on peak total efficiency in accordance with ISO 12759/ AMCA 205.
- Please consult Kruger for fan selection of class III.



BNC-Q 1120

FEG 80

Op Limit	Cl. I	Cl. II	Cl. III
Type	DI	DII	DIII
M.kW	34	74.5	152
M.RPM	1000	1300	1650

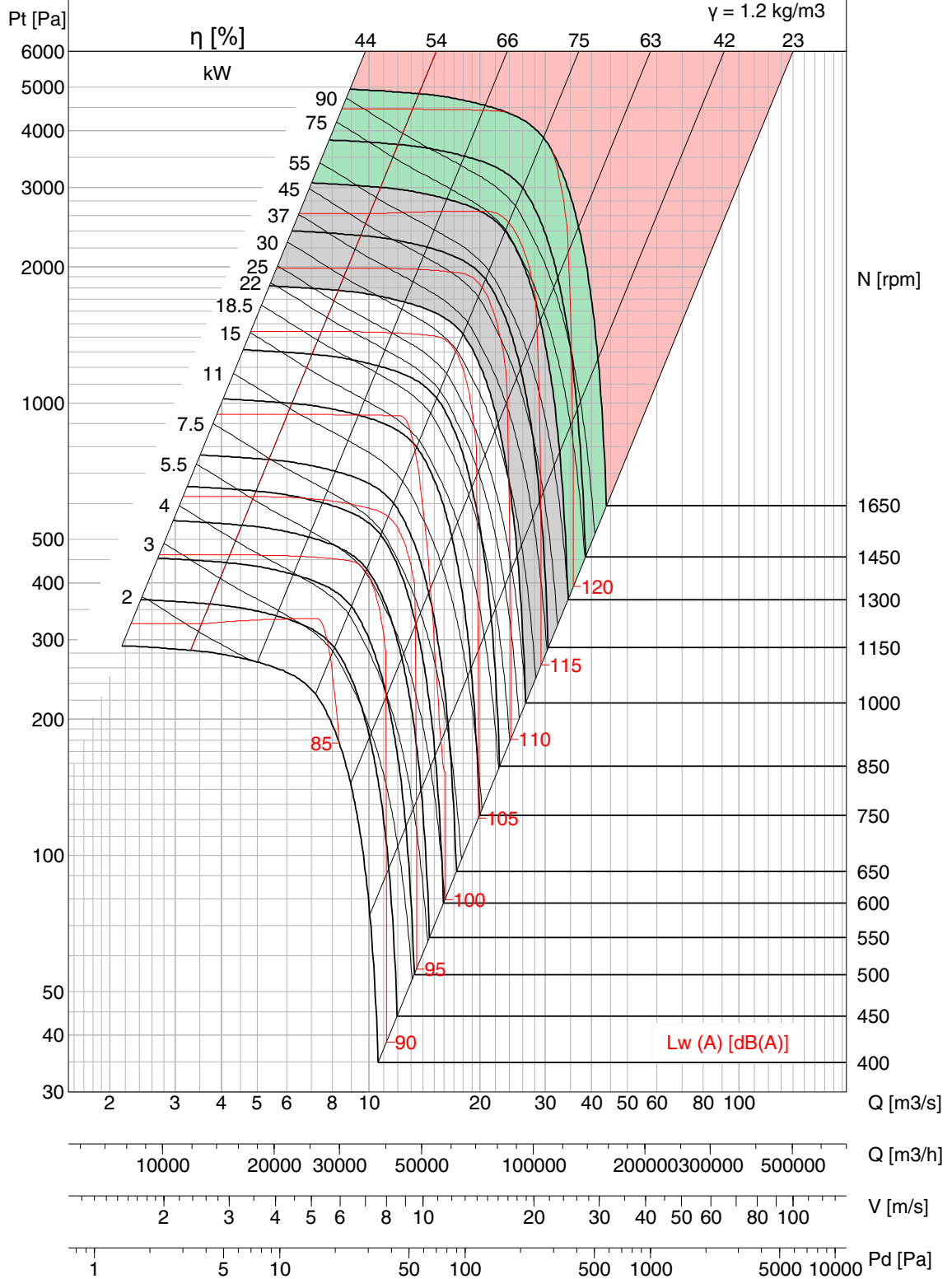

- Performance certified is for installation type A – free inlet, free outlet. Performance ratings do not include the effects of appurtenances (accessories). Power rating kW does not include transmission losses.
- Outlet Velocity of Model BNC is calculated in accordance with the fan outlet area as defined in AMCA 210 Annex H, Figure H.4.
- Values shown are for outlet Lwo A sound power levels for Installation Type A: free inlet, free outlet.
- The A-weighted sound ratings shown have been calculated per AMCA International Standard 301.
- Fan Efficiency Grade (FEG) is based on peak total efficiency in accordance with ISO 12759/ AMCA 205.
- Please consult Kruger for fan selection of class III.



BNC-P 1250

FEG 80

Op Limit	Cl. I	Cl. II	Cl. III
Type	DI	DII	DIII
M.kW	30.3	65.5	135
M.RPM	850	1100	1400

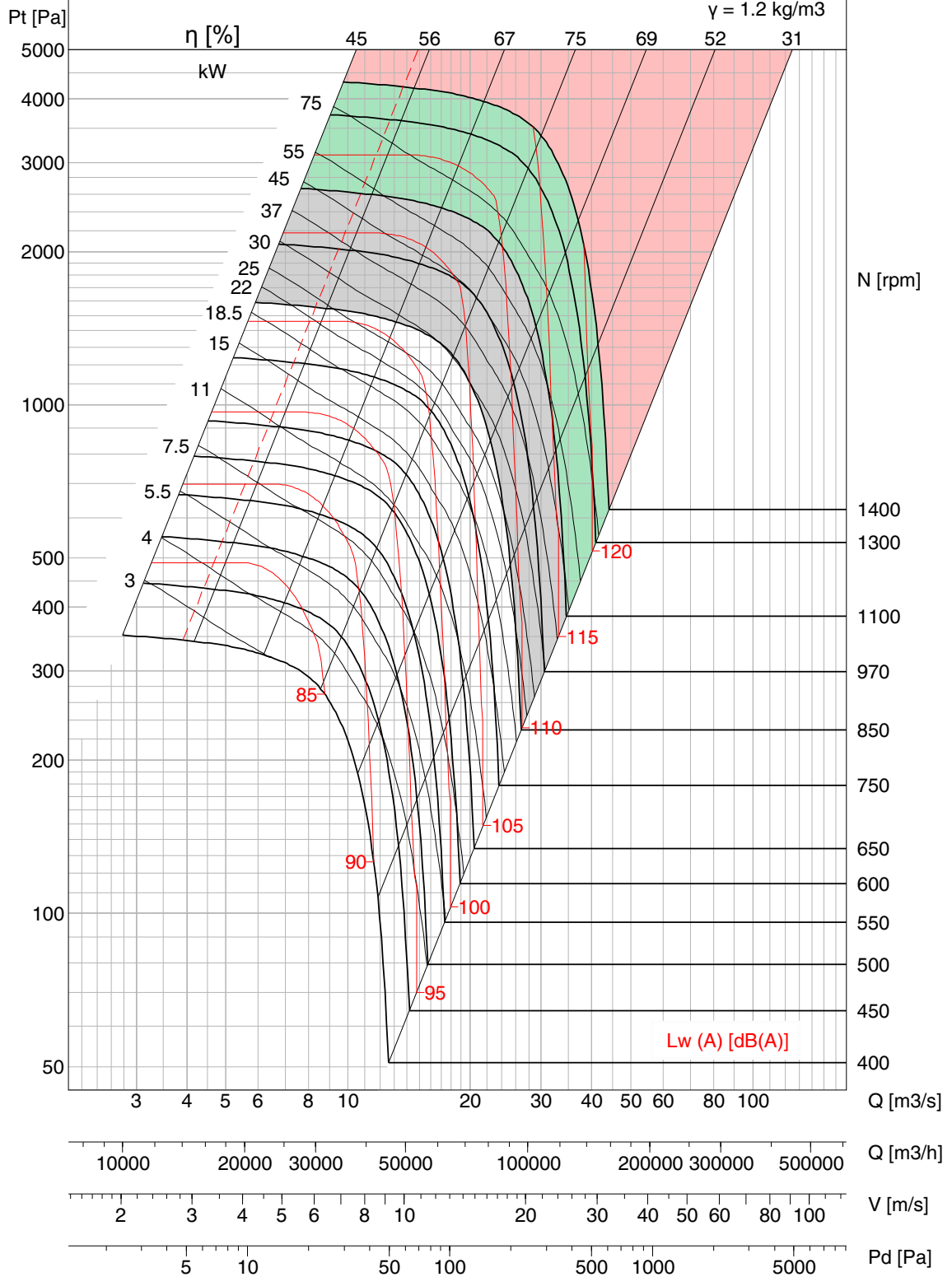

- Performance certified is for installation type A – free inlet, free outlet. Performance ratings do not include the effects of appurtenances (accessories). Power rating kW does not include transmission losses.
- Outlet Velocity of Model BNC is calculated in accordance with the fan outlet area as defined in AMCA 210 Annex H, Figure H.4.
- Values shown are for outlet Lwo A sound power levels for Installation Type A: free inlet, free outlet.
- The A-weighted sound ratings shown have been calculated per AMCA International Standard 301.
- Fan Efficiency Grade (FEG) is based on peak total efficiency in accordance with ISO 12759/ AMCA 205.
- Please consult Kruger for fan selection of class III.



BNC-R 1250

FEG 80

Op Limit	Cl. I	Cl. II	Cl. III
Type	DI	DII	DIII
M.kW	34	75	145
M.RPM	870	1130	1420

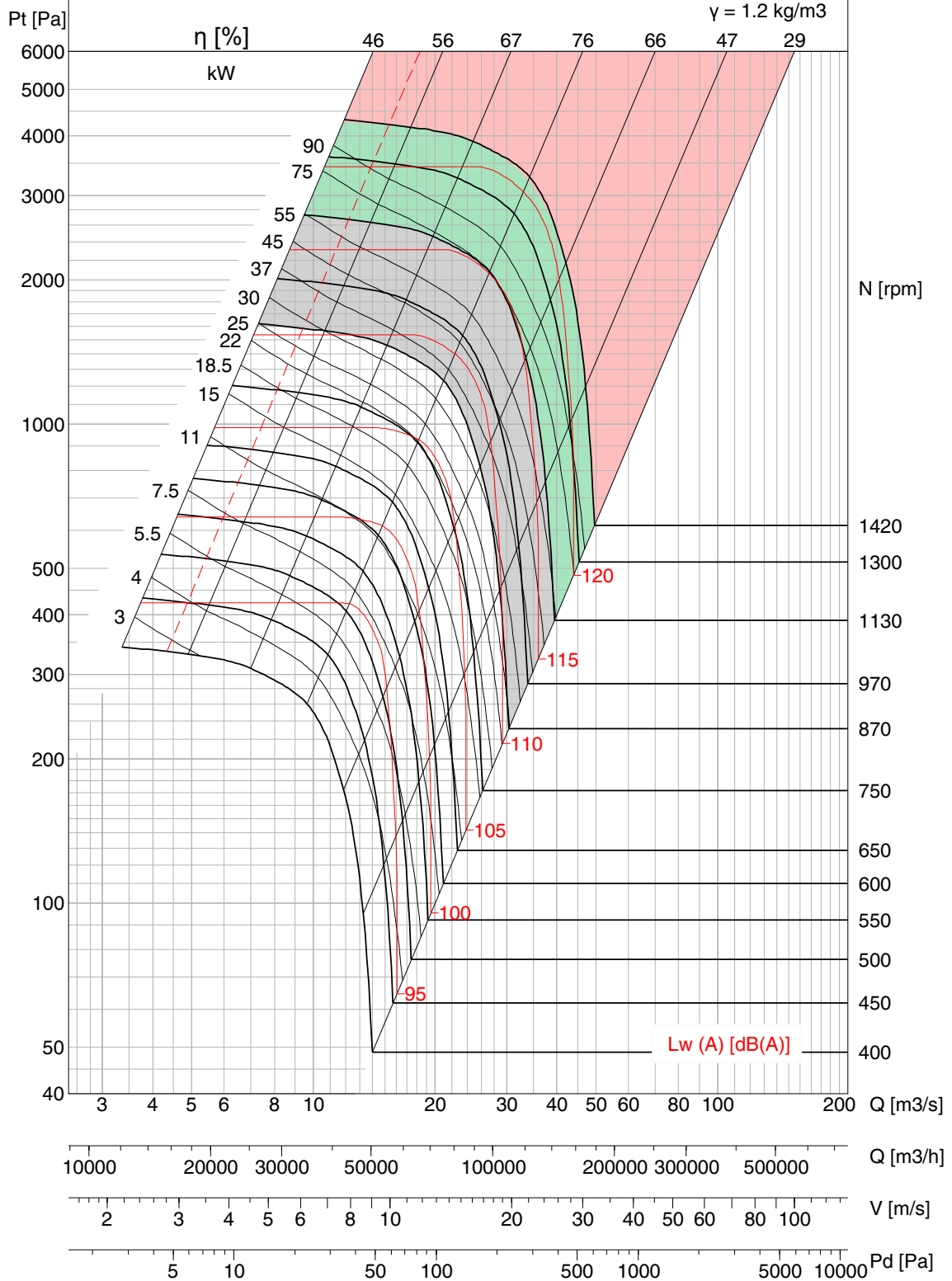

- Performance certified is for installation type A – free inlet, free outlet. Performance ratings do not include the effects of appurtenances (accessories).
- Power rating kW does not include transmission losses.
- Outlet Velocity of Model BNC is calculated in accordance with the fan outlet area as defined in AMCA 210 Annex H, Figure H.4.
- Values shown are for outlet Lwo A sound power levels for Installation Type A: free inlet, free outlet.
- The A-weighted sound ratings shown have been calculated per AMCA International Standard 301.
- Fan Efficiency Grade (FEG) is based on peak total efficiency in accordance with ISO 12759/ AMCA 205.
- Please consult Kruger for fan selection of class III.



BNC-Q 1250

FEG 80

Op Limit	Cl. I	Cl. II	Cl. III
Type	DI	DII	DIII
M.kW	42	94	183
M.RPM	890	1170	1460

$\gamma = 1.2 \text{ kg/m}^3$

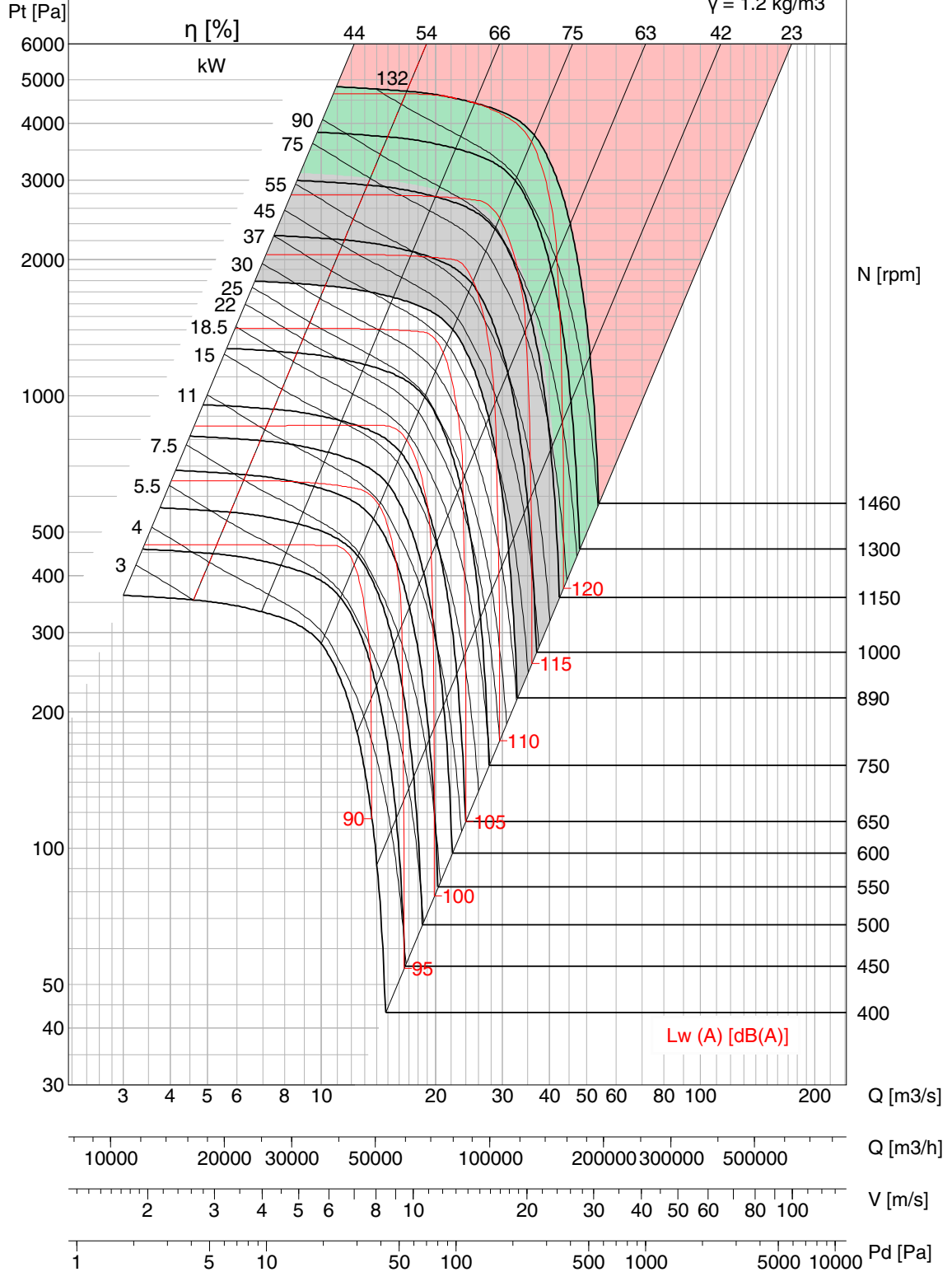

- Performance certified is for installation type A – free inlet, free outlet. Performance ratings do not include the effects of appurtenances (accessories).
- Power rating kW does not include transmission losses.
- Outlet Velocity of Model BNC is calculated in accordance with the fan outlet area as defined in AMCA 210 Annex H, Figure H.4.
- Values shown are for outlet Lwo A sound power levels for Installation Type A: free inlet, free outlet.
- The A-weighted sound ratings shown have been calculated per AMCA International Standard 301.
- Fan Efficiency Grade (FEG) is based on peak total efficiency in accordance with ISO 12759/ AMCA 205.
- Please consult Kruger for fan selection of class III.



BNC-P 1400

FEG 80

Op Limit	Cl. I	Cl. II	Cl. III
Type	DI	DII	DIII
M.kW	37	82	170
M.RPM	750	980	1250

$\gamma = 1.2 \text{ kg/m}^3$

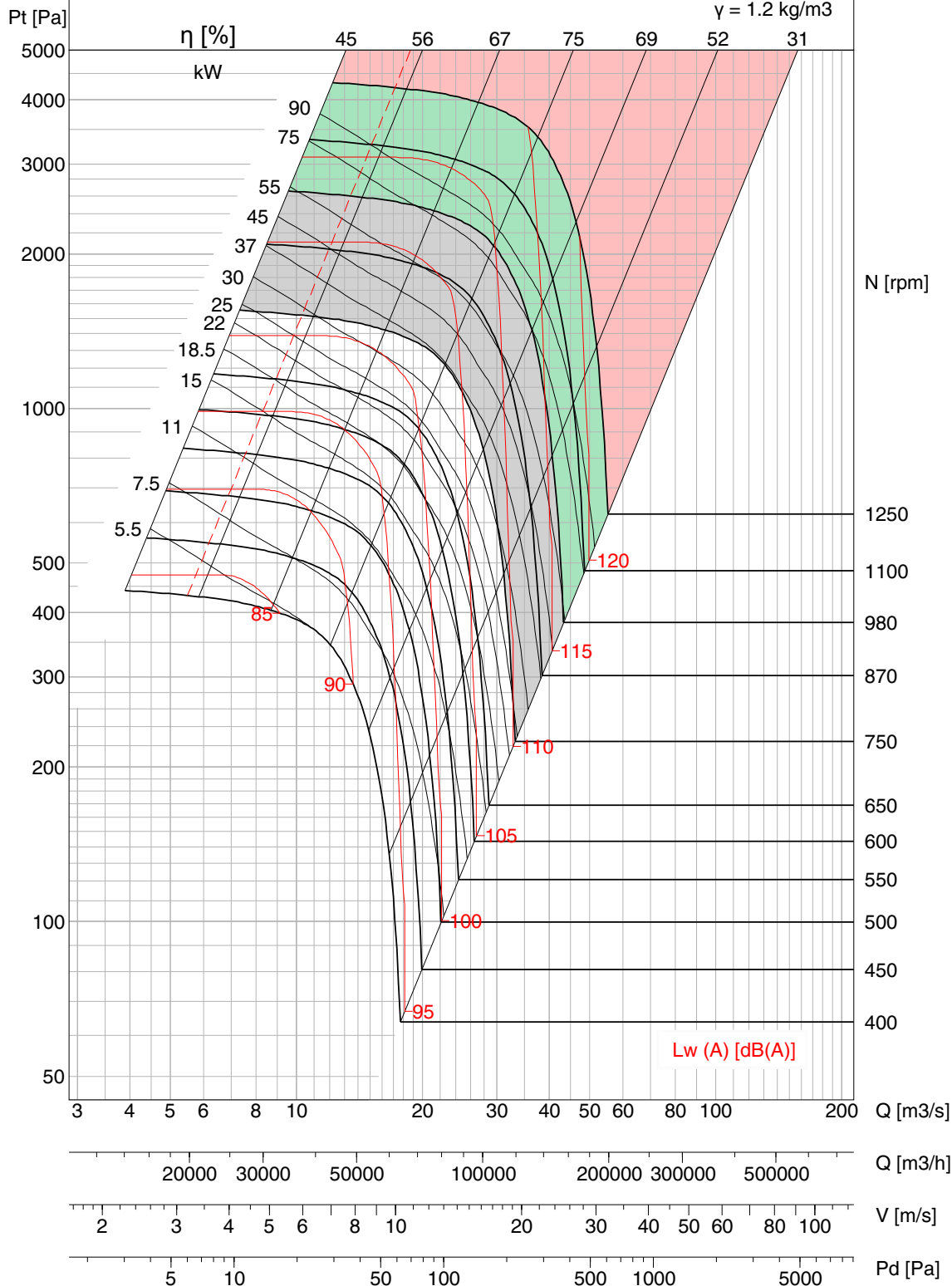

- Performance certified is for installation type A – free inlet, free outlet. Performance ratings do not include the effects of appurtenances (accessories). Power rating kW does not include transmission losses.
- Outlet Velocity of Model BNC is calculated in accordance with the fan outlet area as defined in AMCA 210 Annex H, Figure H.4.
- Values shown are for outlet Lwo A sound power levels for Installation Type A: free inlet, free outlet.
- The A-weighted sound ratings shown have been calculated per AMCA International Standard 301.
- Fan Efficiency Grade (FEG) is based on peak total efficiency in accordance with ISO 12759/ AMCA 205.
- Please consult Kruger for fan selection of class III.



BNC-R 1400

FEG 80

Op Limit	Cl. I	Cl. II	Cl. III
Type	DI	DII	DIII
M.kW	42	91.5	187
M.RPM	770	1000	1270

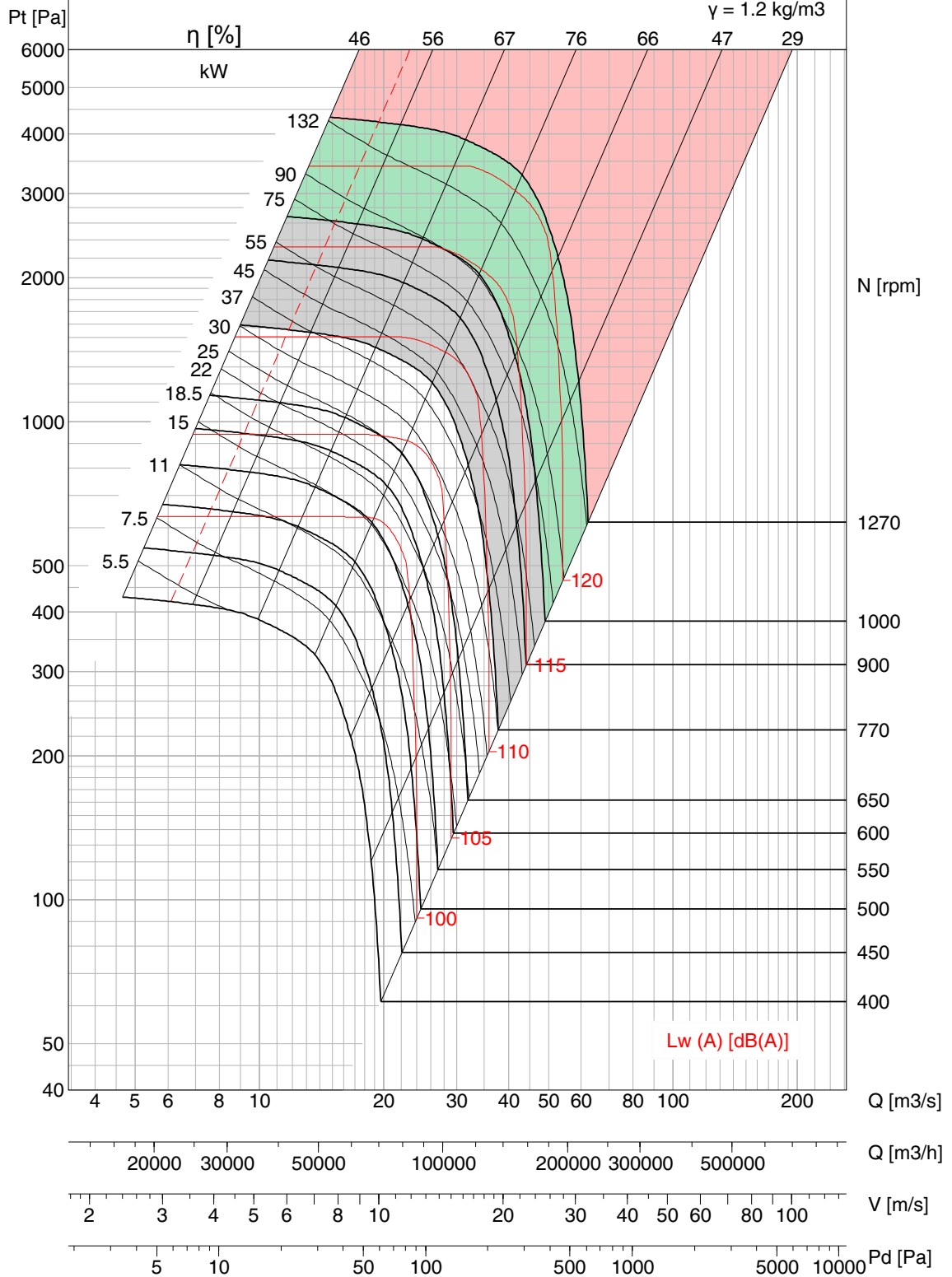

- Performance certified is for installation type A – free inlet, free outlet. Performance ratings do not include the effects of appurtenances (accessories). Power rating kW does not include transmission losses.
- Outlet Velocity of Model BNC is calculated in accordance with the fan outlet area as defined in AMCA 210 Annex H, Figure H.4.
- Values shown are for outlet Lwo A sound power levels for Installation Type A: free inlet, free outlet.
- The A-weighted sound ratings shown have been calculated per AMCA International Standard 301.
- Fan Efficiency Grade (FEG) is based on peak total efficiency in accordance with ISO 12759/ AMCA 205.
- Please consult Kruger for fan selection of class III.



BNC-Q 1400

FEG 80

Op Limit	Cl. I	Cl. II	Cl. III
Type	DI	DII	DIII
M.kW	53	113	227
M.RPM	800	1030	1300

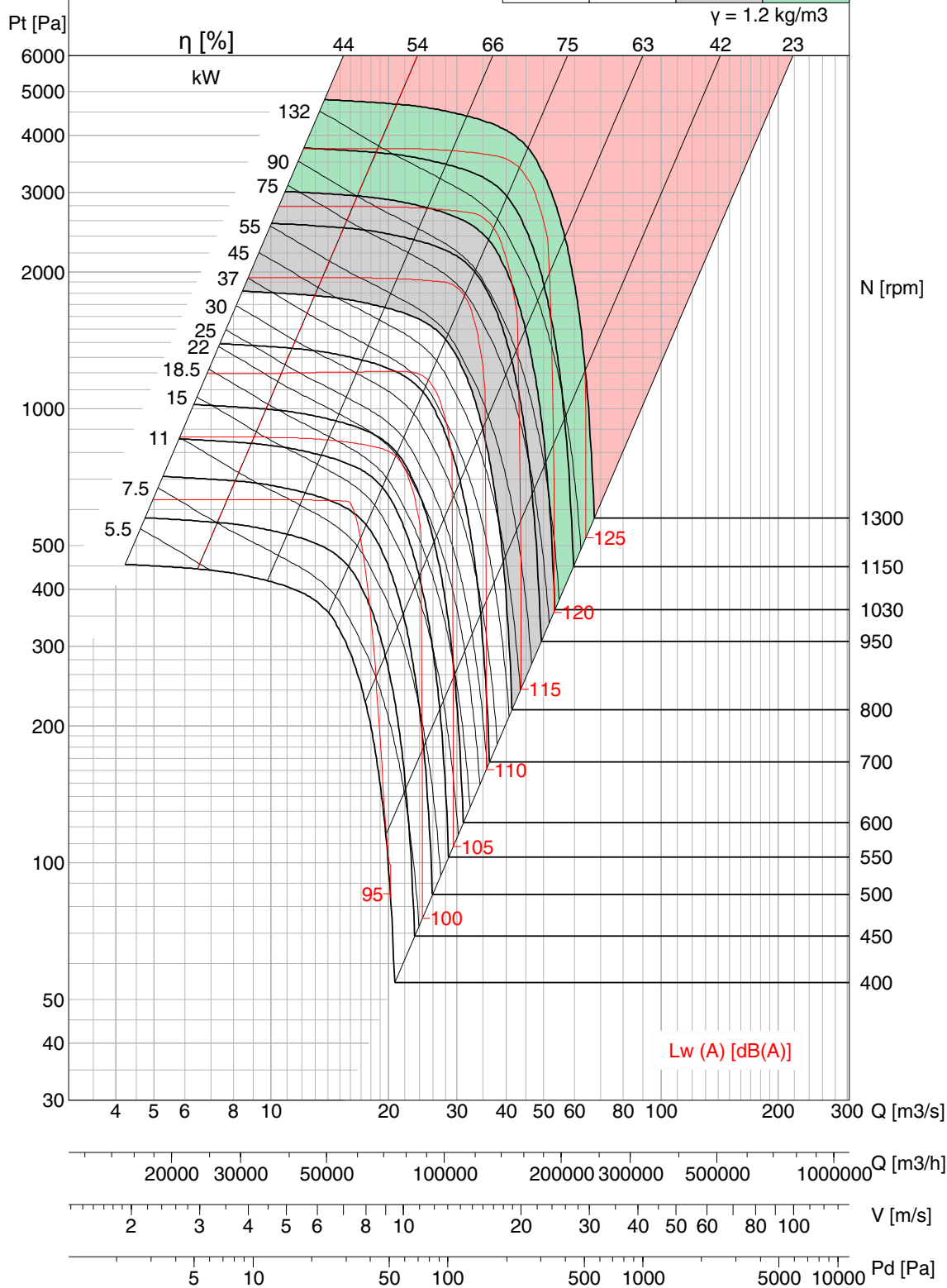

- Performance certified is for installation type A – free inlet, free outlet. Performance ratings do not include the effects of appurtenances (accessories). Power rating kW does not include transmission losses.
- Outlet Velocity of Model BNC is calculated in accordance with the fan outlet area as defined in AMCA 210 Annex H, Figure H.4.
- Values shown are for outlet Lwo A sound power levels for Installation Type A: free inlet, free outlet.
- The A-weighted sound ratings shown have been calculated per AMCA International Standard 301.
- Fan Efficiency Grade (FEG) is based on peak total efficiency in accordance with ISO 12759/ AMCA 205.
- Please consult Kruger for fan selection of class III.



BNC-P 1600

FEG 80

Op Limit	Cl. I	Cl. II	Cl. III
Type	DI	DII	DIII
M.kW	49	108	225
M.RPM	660	860	1100

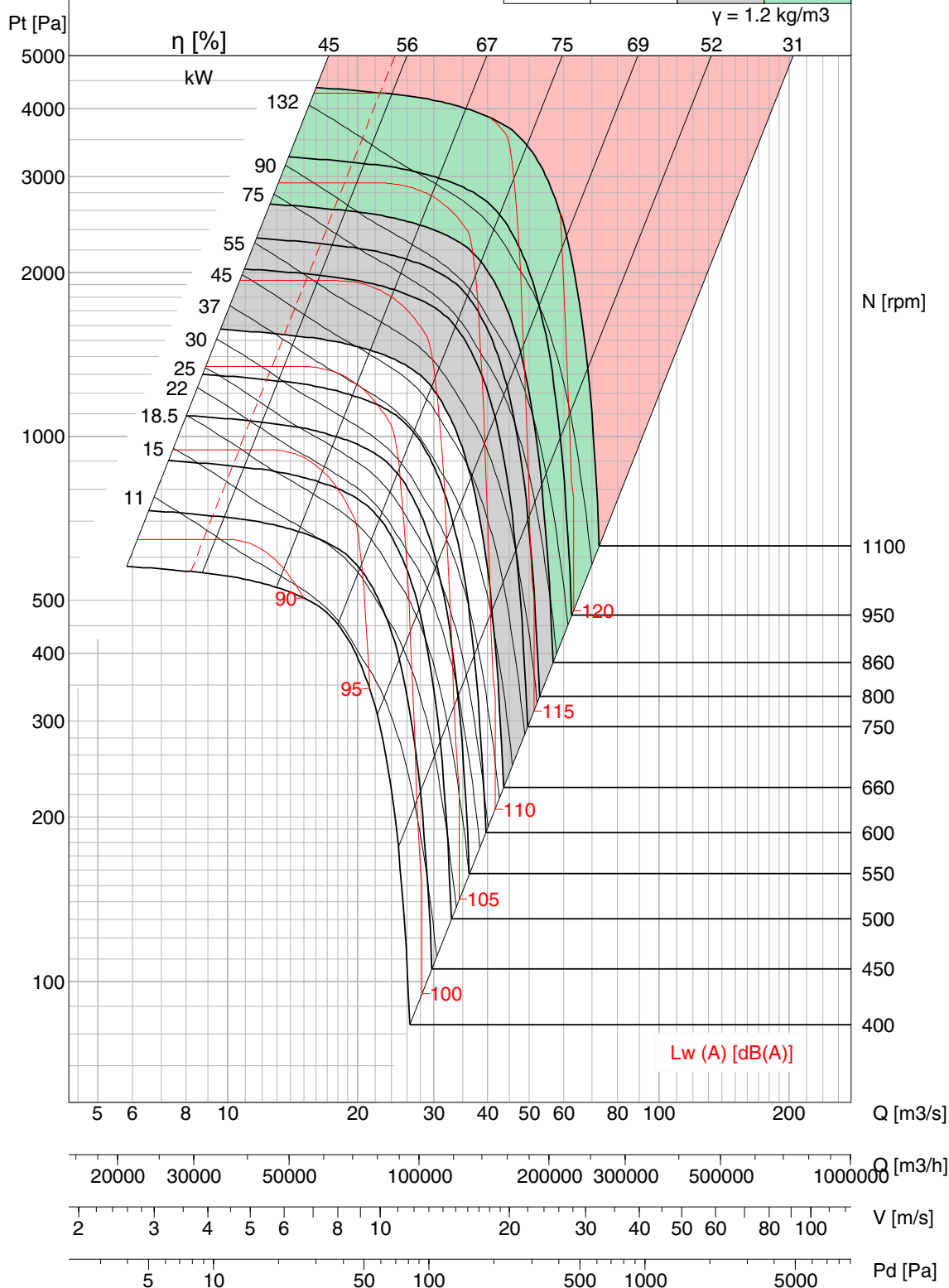

- Performance certified is for installation type A – free inlet, free outlet. Performance ratings do not include the effects of appurtenances (accessories). Power rating kW does not include transmission losses.
- Outlet Velocity of Model BNC is calculated in accordance with the fan outlet area as defined in AMCA 210 Annex H, Figure H.4.
- Values shown are for outlet Lwo A sound power levels for Installation Type A: free inlet, free outlet.
- The A-weighted sound ratings shown have been calculated per AMCA International Standard 301.
- Fan Efficiency Grade (FEG) is based on peak total efficiency in accordance with ISO 12759/ AMCA 205.
- Please consult Kruger for fan selection of class III.



BNC-R 1600

FEG 80

Op Limit	Cl. I	Cl. II	Cl. III
Type	DI	DII	DIII
M.kW	56	121.5	244
M.RPM	680	880	1110

$\gamma = 1.2 \text{ kg/m}^3$

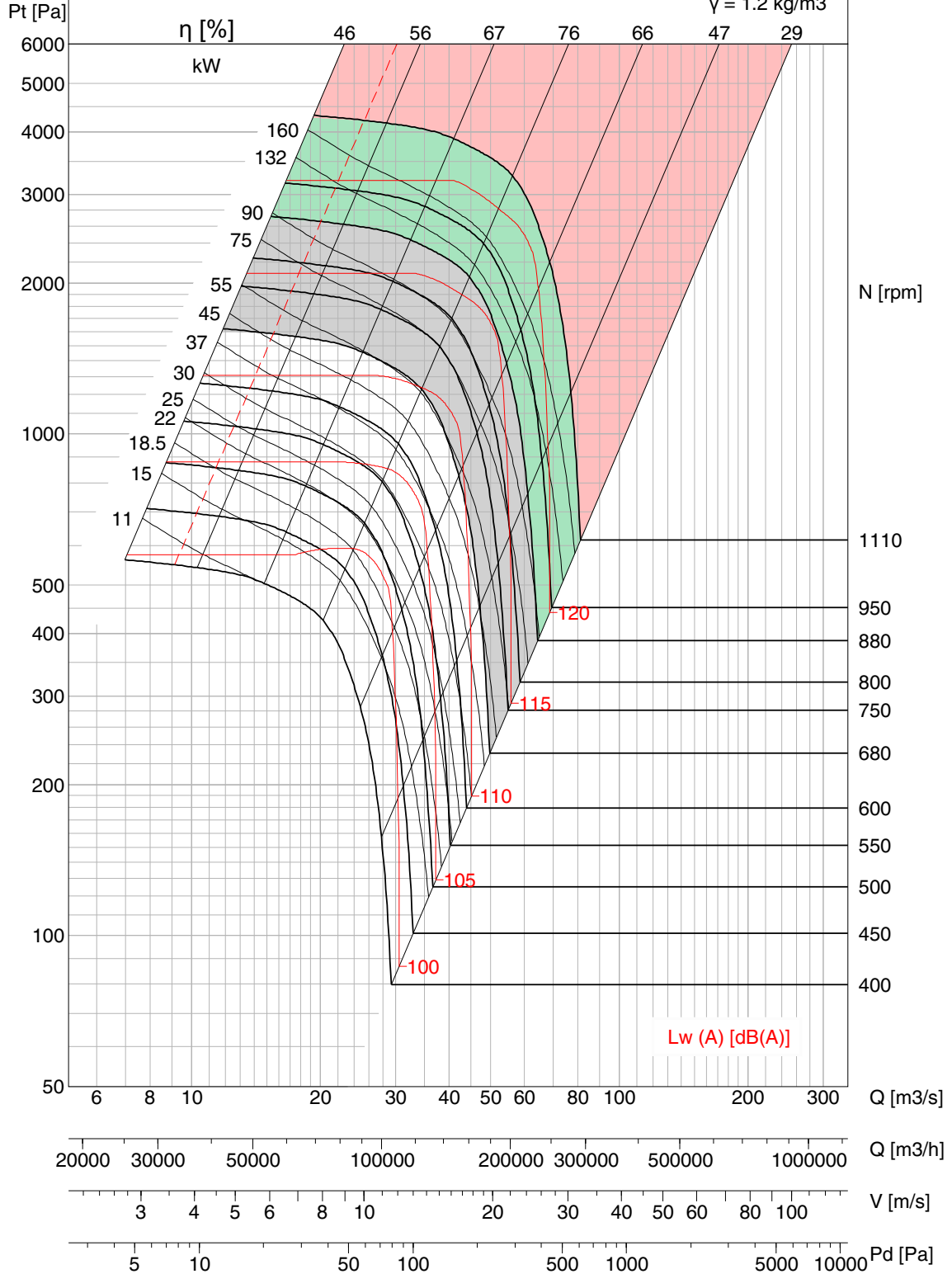

- Performance certified is for installation type A – free inlet, free outlet. Performance ratings do not include the effects of appurtenances (accessories).
- Power rating kW does not include transmission losses.
- Outlet Velocity of Model BNC is calculated in accordance with the fan outlet area as defined in AMCA 210 Annex H, Figure H.4.
- Values shown are for outlet Lwo A sound power levels for Installation Type A: free inlet, free outlet.
- The A-weighted sound ratings shown have been calculated per AMCA International Standard 301.
- Fan Efficiency Grade (FEG) is based on peak total efficiency in accordance with ISO 12759/ AMCA 205.
- Please consult Kruger for fan selection of class III.



BNC-Q 1600

FEG 80

Op Limit	Cl. I	Cl. II	Cl. III
Type	DI	DII	DIII
M.kW	69	147	306
M.RPM	700	900	1150

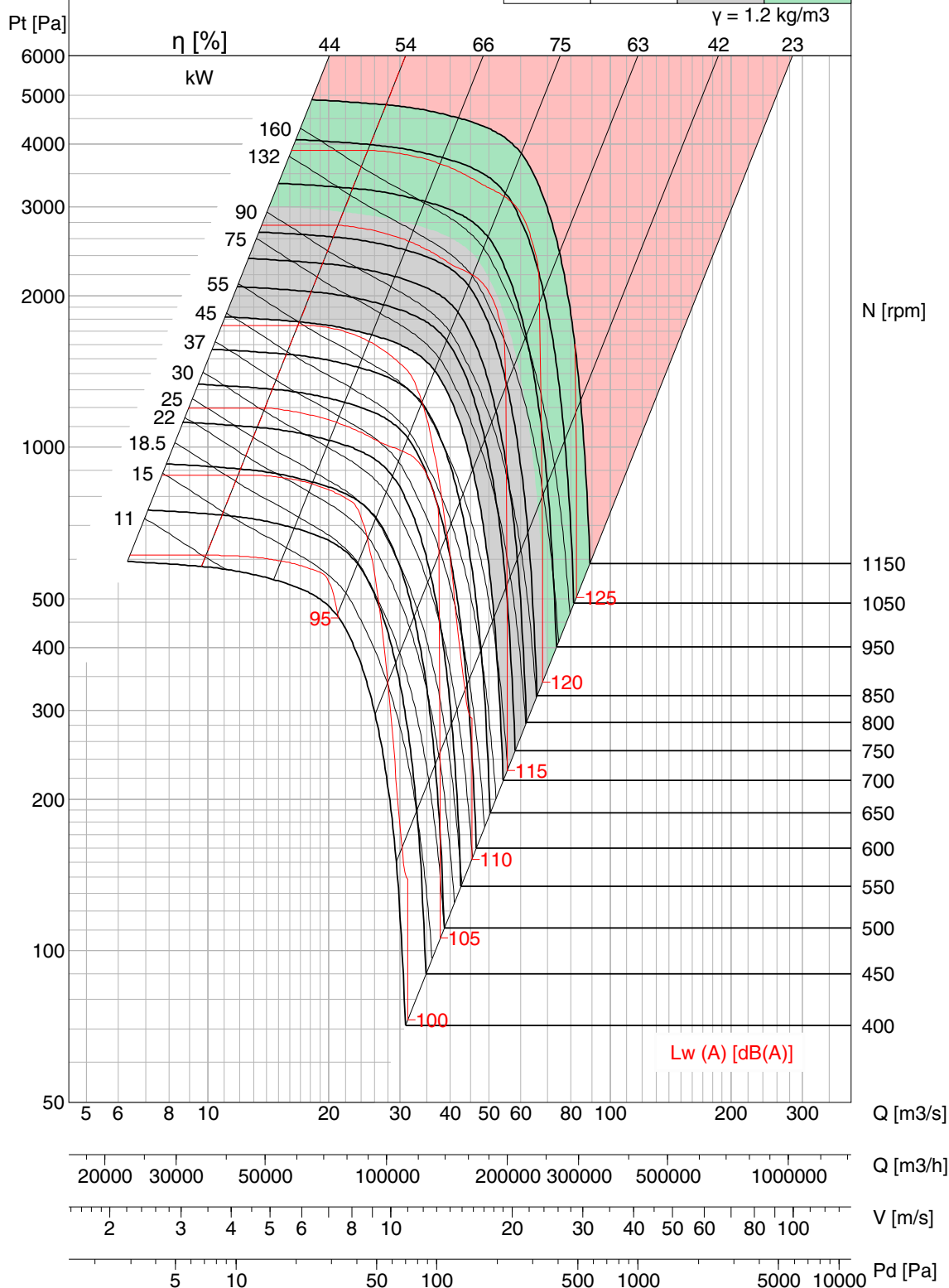

- Performance certified is for installation type A – free inlet, free outlet. Performance ratings do not include the effects of appurtenances (accessories). Power rating kW does not include transmission losses.
- Outlet Velocity of Model BNC is calculated in accordance with the fan outlet area as defined in AMCA 210 Annex H, Figure H.4.
- Values shown are for outlet Lwo A sound power levels for Installation Type A: free inlet, free outlet.
- The A-weighted sound ratings shown have been calculated per AMCA International Standard 301.
- Fan Efficiency Grade (FEG) is based on peak total efficiency in accordance with ISO 12759/ AMCA 205.
- Please consult Kruger for fan selection of class III.



BNC-P 1800

FEG 80

Op Limit	Cl. I	Cl. II	Cl. III
Type	DI	DII	DIII
M.kW	63	140	280
M.RPM	590	770	970

$\gamma = 1.2 \text{ kg/m}^3$

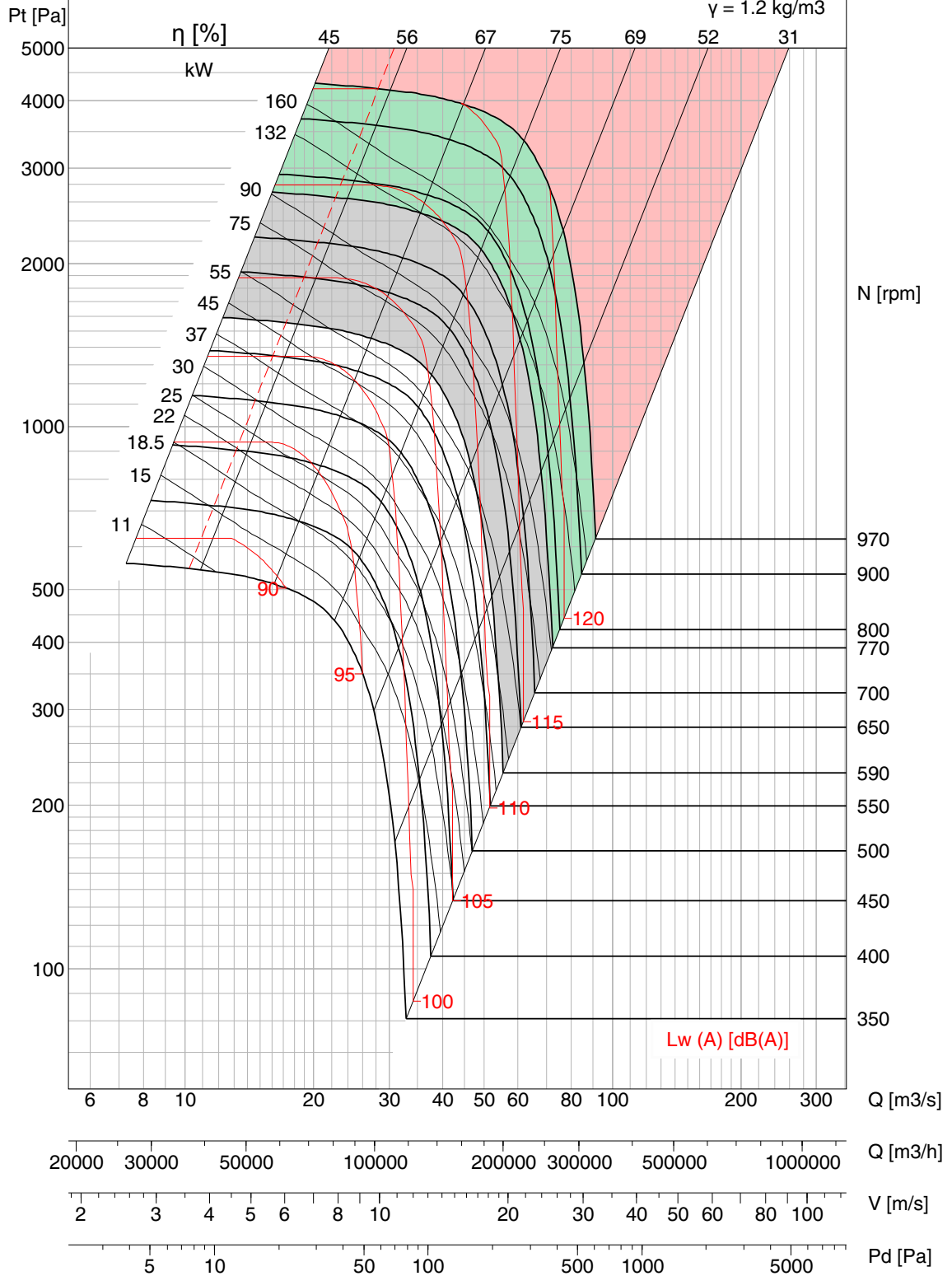

- Performance certified is for installation type A – free inlet, free outlet. Performance ratings do not include the effects of appurtenances (accessories). Power rating kW does not include transmission losses.
- Outlet Velocity of Model BNC is calculated in accordance with the fan outlet area as defined in AMCA 210 Annex H, Figure H.4.
- Values shown are for outlet Lwo A sound power levels for Installation Type A: free inlet, free outlet.
- The A-weighted sound ratings shown have been calculated per AMCA International Standard 301.
- Fan Efficiency Grade (FEG) is based on peak total efficiency in accordance with ISO 12759/ AMCA 205.
- Please consult Kruger for fan selection of class III.



BNC-R 1800

FEG 80

Op Limit	Cl. I	Cl. II	Cl. III
Type	DI	DII	DIII
M.kW	69.3	152	302
M.RPM	600	780	980

$\gamma = 1.2 \text{ kg/m}^3$

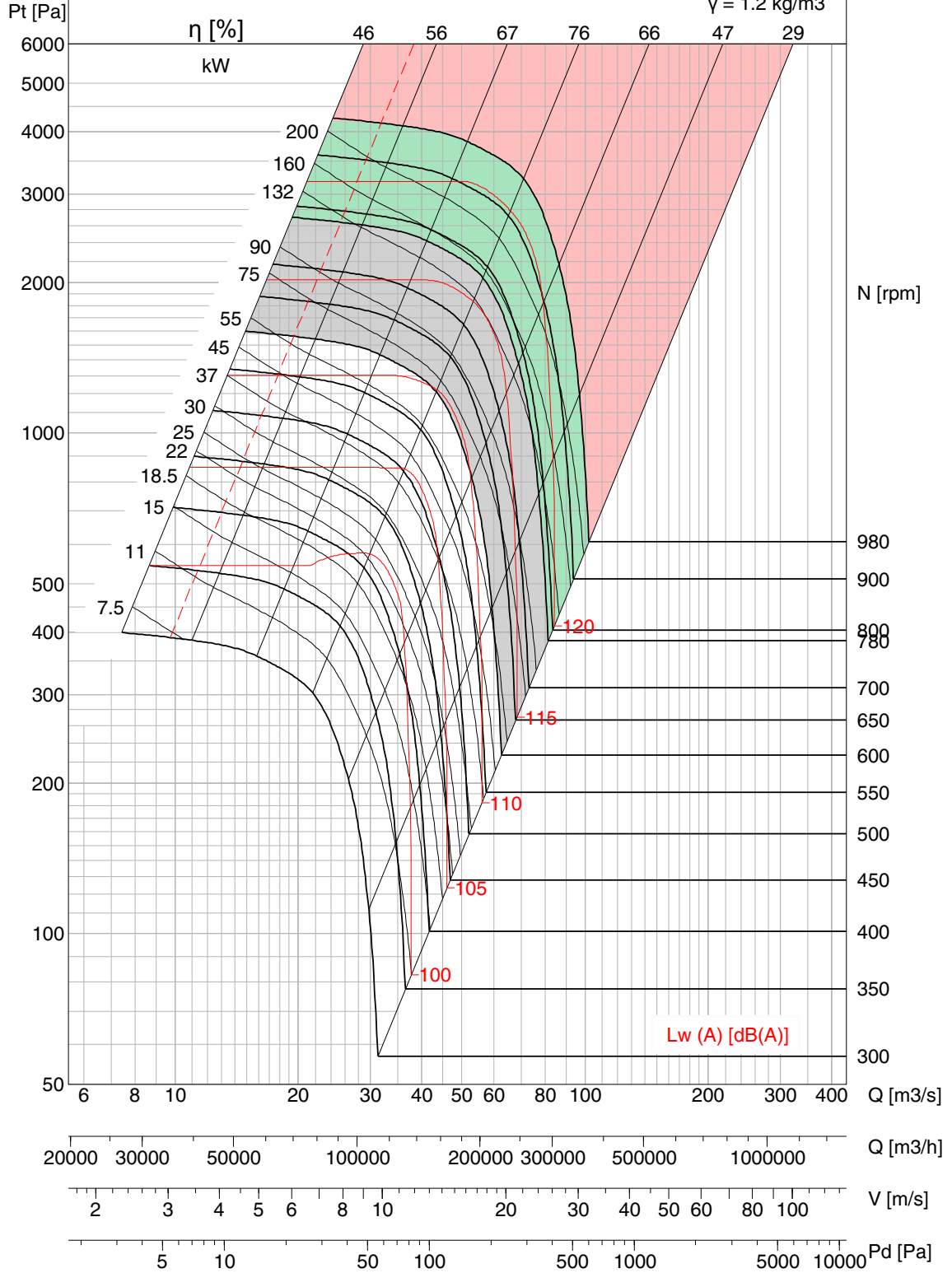

- Performance certified is for installation type A – free inlet, free outlet. Performance ratings do not include the effects of appurtenances (accessories).
- Power rating kW does not include transmission losses.
- Outlet Velocity of Model BNC is calculated in accordance with the fan outlet area as defined in AMCA 210 Annex H, Figure H.4.
- Values shown are for outlet Lwo A sound power levels for Installation Type A: free inlet, free outlet.
- The A-weighted sound ratings shown have been calculated per AMCA International Standard 301.
- Fan Efficiency Grade (FEG) is based on peak total efficiency in accordance with ISO 12759/ AMCA 205.
- Please consult Kruger for fan selection of class III.



BNC-Q 1800

FEG 80

Op Limit	Cl. I	Cl. II	Cl. III
Type	DI	DII	DIII
M.kW	87	193	385
M.RPM	620	810	1020

$\gamma = 1.2 \text{ kg/m}^3$

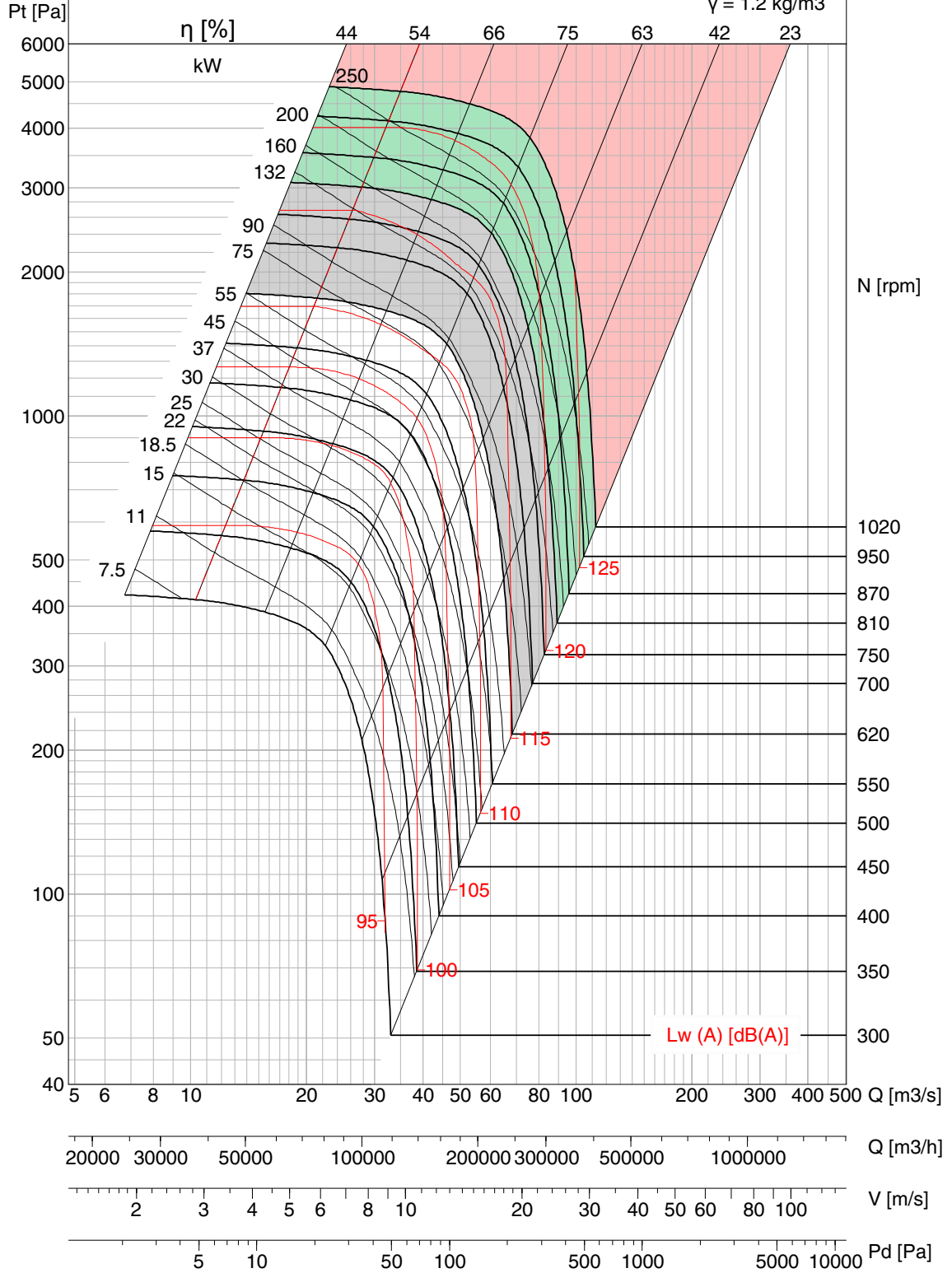

- Performance certified is for installation type A – free inlet, free outlet. Performance ratings do not include the effects of appurtenances (accessories). Power rating kW does not include transmission losses.
- Outlet Velocity of Model BNC is calculated in accordance with the fan outlet area as defined in AMCA 210 Annex H, Figure H.4.
- Values shown are for outlet Lwo A sound power levels for Installation Type A: free inlet, free outlet.
- The A-weighted sound ratings shown have been calculated per AMCA International Standard 301.
- Fan Efficiency Grade (FEG) is based on peak total efficiency in accordance with ISO 12759/ AMCA 205.
- Please consult Kruger for fan selection of class III.

BNC 315~630'D'

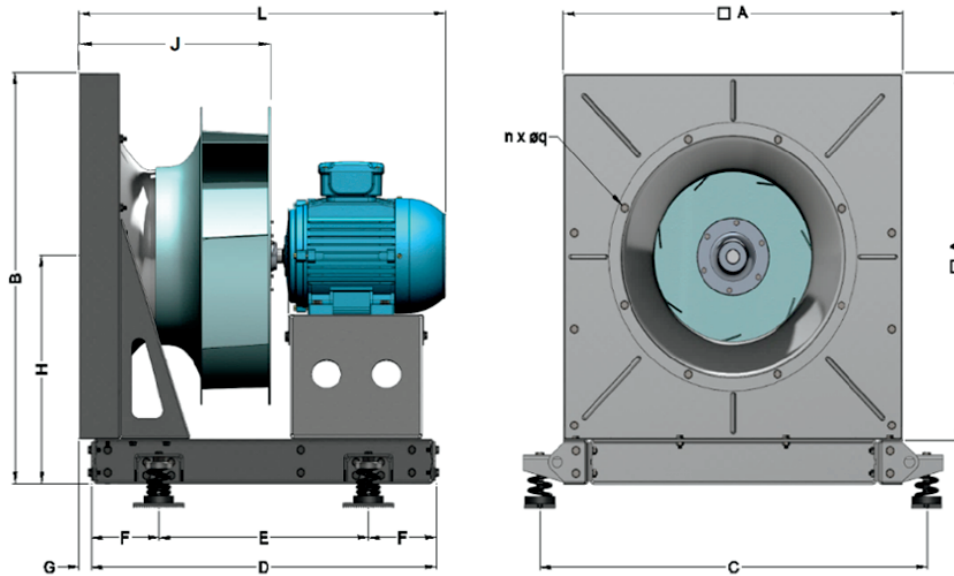

Model	A	B	C	D	E	n x øq	L			Frame size	F	G	H	J			Weight w/o Motor (Kg)												
							Fan Type							Fan Type															
							P	R	Q					P	R	Q													
315	490	555	588	525	325	6 x 9	513	526	536	71	100	28	310	266	279	289	26												
				565	365																							28	
355	530	595	628	580	340	6 x 9	562	575	587	80	120	28	330	289	304	315	35												
				650	410																							38	
400	580	645	678	613	353	8 x 9	629	645	658	90	130	28	355	322	338	351	40												
				803	543																								45
450	630	715	730	673	393	8 x 12	667	685	703	90	140	28	400	358	376	394	45												
				863	583																								54
500	700	785	800	714	434	8 x 12	706	725	747	90	140	28	435	392	412	434	70												
				904	624																								79
				1100	820																								85
560	790	875	890	820	500	8 x 12	768	790	813	100	160	28	480	431	452	476	95												
				990	670																								105
				1150	830																								115
630	890	990	1000	865	545	8 x 12	825	850	870	100	160	28	545	471	496	517	100												
				1035	715																								110
				1185	865																								120

All Dimensions in mm.

BNC 710~1000'D'

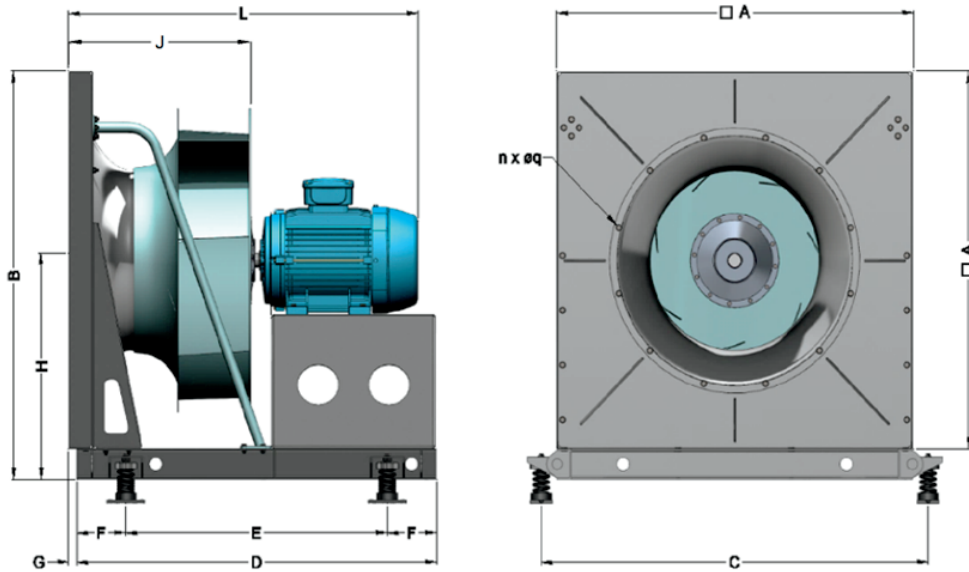

Model	A	B	C	D	E	n x øq	L			Frame size	F	G	H	J			Weight w/o Motor (Kg)							
							Fan Type							Fan Type										
							P	R	Q					P	R	Q								
710	1000	1100	1100	938	618	8 x 12	888	916	939	112	160	28	600	522	550	573	140							
				1128	808		983	1011	1034	132								200	225	250	280	170		
							1123	1151	1174	160														
							1148	1176	1199	180														
							1223	1251	1274	200														
							1268	1296	1319	225														
							1333	1361	1384	250														
				1423	1451		1474	280	190															
				1328	1008		1024	1056		1082							132	160	28	660	575	607	633	185
							1159	1191		1217							160							
1194	1226	1252	180																					
1248	1280	1307	200																					
800	1120	1220	1230	1130	810	8 x 12	1267	1299	1326	225	170	28	720	630	665	695	195							
				1230	910		1332	1364	1391	250														
				1380	1060		1422	1454	1481	280							215							
				1252	912		12 x 12	1225	1259	1289								160	170	28	720	630	665	695
								1255	1289	1319							180							
								1325	1359	1389							200							
								1390	1424	1454							225							
								1455	1489	1519							250							
1545	1579	1609	280																					
900	1240	1340	1350	1342	1002	12 x 12	1825	1859	1889	315	230	28	820	713	751	784	265							
				1500	1160		1886	1924	1957	315														
				1620	1280		1291	1329	1362	160							230	28	820	713	751	784	290	
				1334	874		1321	1359	1392	180														
							1391	1429	1462	200														
							1446	1484	1517	225														
1516	1554	1587	250																					
1580	1120	1606	1644	1677	280	230	28	820	713	751	784	410												
		1710	1250	1886	1924								1957	315	430									
1000	1390	1515	1520	1434	974	12 x 12	1886	1924	1957	315	230	28	820	713		751	784	430						
				1580	1120		1886	1924	1957	315														

All Dimensions in mm.

BNC 1120~1800'D'

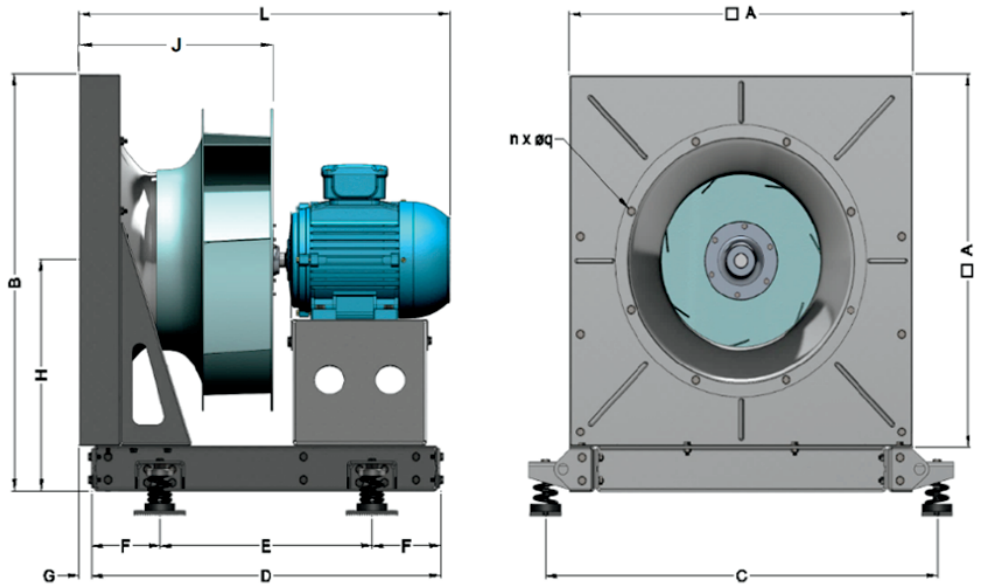

Model	A	B	C	D	E	n x øq	L			Frame size	F	G	H	J			Weight w/o Motor (Kg)
							Fan Type							Fan Type			
							P	R	Q					P	R	Q	
1120	1550	1700	1660	1450	900	12 x 12	1410	1454	1491	180	275	28	925	807	851	888	510
				1600	1050		1480	1524	1561	200							540
				1750	1200		1515	1559	1596	225							590
							1604	1639	1676	250							
							1705	1749	1786	280							
1250	1700	1850	1810	1540	940	14 x 12	1494	1544	1585	180	300	28	1000	872	922	963	650
				1690	1090		1564	1614	1655	200							685
				1890	1290		1599	1649	1690	225							
							1664	1714	1755	250							
							1789	1839	1880	280							
2069	2119	2160	315		735												
1400	1900	2050	2010	1612	1012	16 x 16	1563	1617	1666	180	300	28	1100	952	1006	1052	650
				1780	1180		1633	1687	1736	200							700
				1930	1330		1678	1732	1781	225							
							1868	1922	1971	280							
							2148	2202	2251	315							
2523	2577	2626	355		800												
1600	2204	2354	2354	1882	1252	18 x 16	1695	1768	1821	200	315	28	1252	1100	1173	1226	900
				1740	1813		1866	225									
				1805	1878		1931	250									
				1895	1968		2021	280									
				2175	2248		2301	315									
2550	2623	2676	355		1000												
1800	2480	2630	2630	2117	1487	32 x 16	1912	1983	2043	225	315	28	1390	1272	1343	1403	1080
				1977	2048		2108	250									
				2067	2138		2198	280									
				2347	2418		2478	315									
				2722	2793		2853	355		1180							

All Dimensions in mm.

NOTES

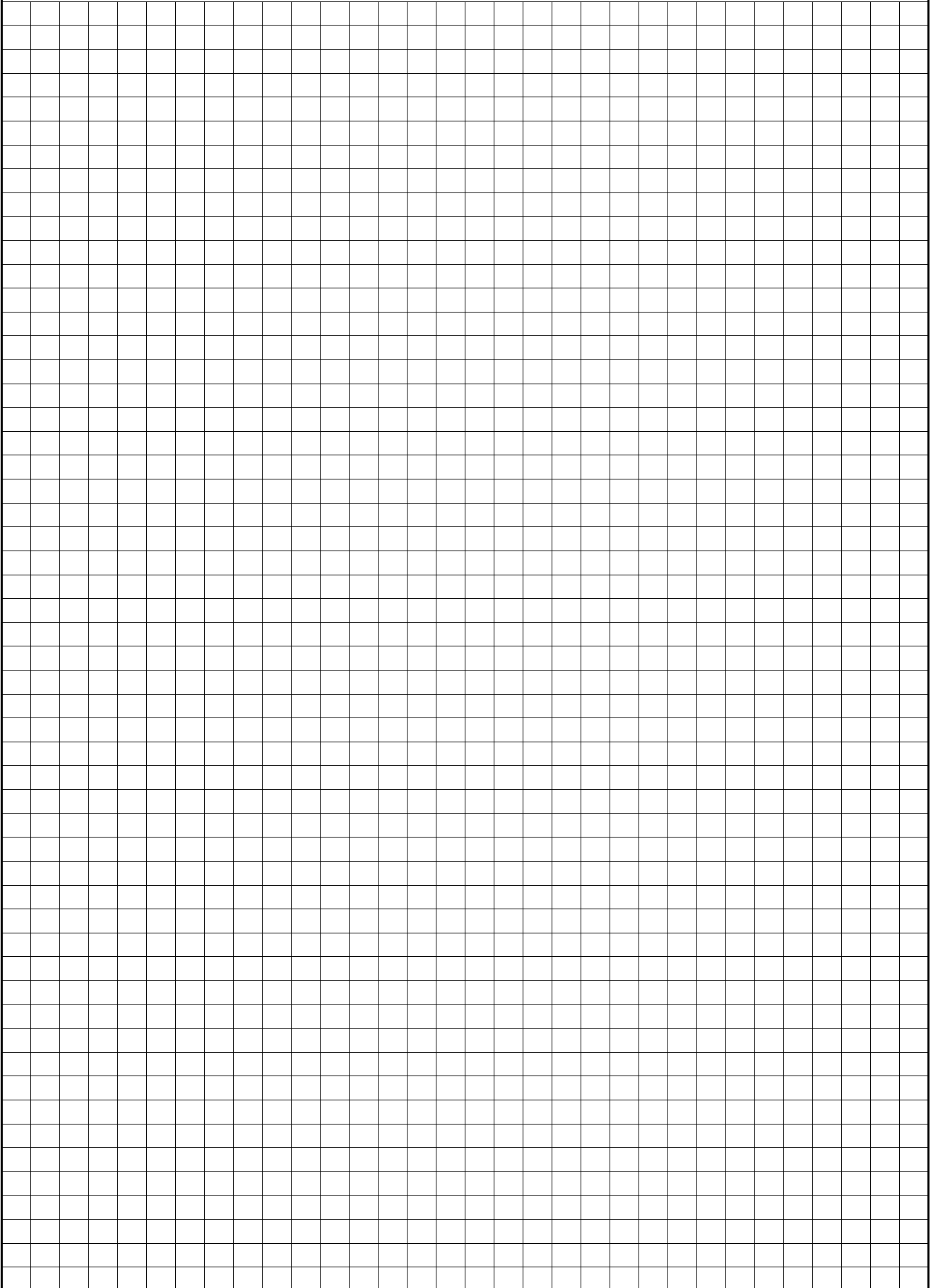

Operational Limits - BNC-P

	315	355	400	450	500	560	630	710	800	900	1000	1120	1250	1400	1600	1800		
Maximum Absorbed Power	CL.I	kW	2.2	3	3.3	4.3	5.3	6.4	7.4	9.7	12.3	15.3	19.3	24.5	30.3	37	49	63
	CL.II	kW	5	6	7.2	9.5	11.5	13.4	16	21.3	26.7	33.5	42.4	53	65.5	82	108	140
	CL.III	kW	9.7	11.5	14	19	23.2	26.7	33	42.3	53	67.4	86.5	106	135	170	225	280
Maximum Fan Speed	CL.I	rpm	3500	3100	2750	2450	2200	1950	1700	1520	1350	1170	1060	950	850	750	660	590
	CL.II	rpm	4600	4000	3550	3170	2850	2500	2200	1980	1750	1520	1380	1230	1100	980	860	770
	CL.III	rpm	5800	5000	4450	4000	3600	3150	2800	2490	2200	1920	1750	1550	1400	1250	1100	970
Temperature Range/ Min. -20°C	CL.I-CL.III	Max.°C	55	55	55	55	55	55	55	55	55	55	55	55	55	55	55	55
Wheel	Diameter	mm	315	355	400	450	500	560	630	710	800	900	1000	1120	1250	1400	1600	1800
	J = PD ² /4	kgm ²	0.13	0.22	0.34	0.62	1.07	1.88	2.99	5.27	9.52	14.7	24.7	45.1	72.4	117	234	405

Operational Limits - BNC-R

	315	355	400	450	500	560	630	710	800	900	1000	1120	1250	1400	1600	1800		
Maximum Absorbed Power	CL.I	kW	2.4	3	4.6	4.6	6	7.1	9	11	14.6	18	21.4	27.5	34	42	56	69.3
	CL.II	kW	5.2	6.8	10	10.6	13	15.6	19	25	31.5	39	47	58.5	75	91.5	121.5	152
	CL.III	kW	10.4	13.3	20	21.5	27	31.5	38	49	62	78	94	118	145	187	244	302
Maximum Fan Speed	CL.I	rpm	3550	3180	3000	2470	2220	1950	1720	1530	1370	1210	1080	970	870	770	680	600
	CL.II	rpm	4600	4150	3890	3200	2880	2540	2230	1990	1770	1570	1400	1250	1130	1000	880	780
	CL.III	rpm	5800	5200	4900	4050	3650	3200	2800	2500	2220	1980	1770	1580	1420	1270	1110	980
Temperature Range/ Min. -20°C	CL.I-CL.III	Max.°C	55	55	55	55	55	55	55	55	55	55	55	55	55	55	55	55
Wheel	Diameter	mm	315	355	400	450	500	560	630	710	800	900	1000	1120	1250	1400	1600	1800
	J = PD ² /4	kgm ²	0.13	0.23	0.36	0.64	1.12	1.95	3.11	5.53	10.0	15.4	26.0	47.0	75.5	122	244	420

Operational Limits - BNC-Q

	315	355	400	450	500	560	630	710	800	900	1000	1120	1250	1400	1600	1800		
Maximum Absorbed Power	CL.I	kW	3	4	5	6.1	7.6	9	11	13.8	18.7	22.2	27	34	42	53	69	87
	CL.II	kW	6.5	8.6	11	13.6	16.7	20.5	24	31.2	38.8	46.5	59	74.5	94	113	147	193
	CL.III	kW	13	17	22	27.5	33.5	40.8	50	62.7	79.4	97.7	122	152	183	227	306	385
Maximum Fan Speed	CL.I	rpm	3700	3370	2900	2600	2350	2050	1800	1600	1450	1250	1120	1000	890	800	700	620
	CL.II	rpm	4800	4370	3750	3400	3050	2700	2350	2100	1850	1600	1450	1300	1170	1030	900	810
	CL.III	rpm	6100	5500	4750	4300	3850	3400	3000	2650	2350	2050	1850	1650	1460	1300	1150	1020
Temperature Range/ Min. -20°C	CL.I-CL.III	Max.°C	55	55	55	55	55	55	55	55	55	55	55	55	55	55	55	55
Wheel	Diameter	mm	315	355	400	450	500	560	630	710	800	900	1000	1120	1250	1400	1600	1800
	J = PD ² /4	kgm ²	0.14	0.24	0.37	0.67	1.16	2.01	3.21	5.75	10.3	15.9	27.0	48.7	78.1	126	253	434

THAILAND (Regional Head Quarter)

KRUGER VENTILATION INDUSTRIES ASIA CO. LTD.
30/159 Moo 1, Sinsakorn Industrial Estate, Chetsadawithi Road,
Khok Kham Mueng, Samuthsakorn 74000, Thailand
Tel: +662 1054298 Fax: +662 0248256-9
Website: www.krugerfan.com

THAILAND

KRUGER VENTILATION IND. (THAILAND) CO. LTD.
30/105 Moo 1, Sinsakorn Industrial Estate, Chetsadawithi Road,
Khok Kham Mueng, Samuthsakorn 74000, Thailand
Tel: +662 1050399 Fax: +662 1050370-2
Email: mktg@kruger.co.th

INDIA

KRUGER VENTILATION INDUSTRIES (INDIA) PVT. LTD.
Kruger Centre, Mumbai-Nasik Highway, Kalamgaon, Shahapur,
Thane 421601, Maharashtra, India
Tel: +91 9960558899/9975577211
Email: sales@krugerindia.com

INDIA (NORTH)

KRUGER VENTILATION INDUSTRIES (INDIA) PVT. LTD.
Khasra No. 150//20/2/1, 21/1/2, 22/2, 151//16/2/2, Village Rohad,
Tehsil Bahadurgarh, Jhajjar, Haryana-124507, India
Tel: +91-9958991652/9958991660/8586966303
Fax +91-1276-278096
Email: sales.kni@krugerindia.com , service@krugerindia.com

KOREA

NEOMATE CO. LTD.
2-1010, Ace High Tech City B/D, 775 Gyeongin-ro,
Yeongdeungpo-gu, Seoul, Korea. Postal Code 07299
Tel: +82-2-2679-2052 Fax: +82-2-2679-2174
Email: y7890@neomate.co.kr

SINGAPORE

KRUGER ENGINEERING PTE. LTD.
2 Venture Drive #20-23, Vision Exchange,
Singapore 608526.
Tel: +65 68631191 Fax: +65 68631151
Email: mktg@krugerfan.com

AUSTRALIA

S&P KRUGER AUSTRALIA PTY. LTD.
2 Cunningham St, Moorebank N.S.W. 2170
Tel: +61 2-98227747
Fax: +61 2-98227757
Email: info@sandpkruger.com.au

INDONESIA

P.T. KRUGER VENTILATION INDONESIA.
JL. Teuku Umar No.20,
Karawaci - Tangerang 15115, Indonesia
Tel: +62 21-5512288/5513557 Fax: +62 21-5513502
Email: mktg@krugerindo.co.id

VIETNAM

KRUGER VENTILATION INDUSTRIES (VIETNAM) CO. LTD.
Lot A7. 2-4, C2 Road, Thanh Thanh Cong IZ,
Trang Bang Dist. Tay Ninh Province, Vietnam
Tel: +84-276 3585200/01/02 Fax: +84-276 3585199
Email: mktg@krugervn.com

CHINA (GUANGZHOU)

GUANGZHOU KRUGER VENTILATION CO. LTD.
No. 9 Huahui Road, Huashan, Huadu,
Guangzhou, P.R. China 510880
Tel: +86 20-66356635 Fax: +86 20-86786001/86786500
Email: gzkruger@krugergz.com

CHINA (TIANJIN)

TIANJIN KRUGER VENTILATION CO. LTD.
Jingjin Science and Technology Park
Wuqing District, Tianjin, China
Tel: +86 22-22143480/3481 Fax: +86 22-22143482
Email: krugertj@krugertj.com

CHINA (SHANGHAI)

SHANGHAI KRUGER VENTILATION CO., LTD.
No.500 Yuanguo Road, Anting, Jiading District,
Shanghai 201814, P.R. China
Tel: +86 21-69573266 Fax: +86 21-69573296
Email: shkru@krugerchina.com

CHINA (WUHAN)

WUHAN KRUGER VENTILATION CO. LTD.
No. 805, Huian Ave, Dongxihu District, Wuhan,
Hubei, P.R. China 430040
Tel: +86 27- 83248840/83060522/83097505
Fax: +86 27- 83261886
Email: whkruger@krugerwh.com

HONG KONG

KRUGER VENTILATION (HONG KONG) LIMITED.
Flat C, 9/F, Yeung Yiu Chung (No.8) Industrial Building,
20 Wang Hoi Road, Kowloon Bay, Kowloon, Hong Kong
Tel: +852 22469182 Fax: +852 22469187
Email: info@kruger.com.hk

TAIPEI

KRUGER VENTILATION (TAIWAN) CO., LTD.
No. 157, Ping-an Rd, Hengfeng Village, Dayuan Shiang
Taoyuan County 337, Taiwan
Tel: +886 3-3859119 Fax: +886 3-3859118
Email: sales@krugertwn.com.tw

MALAYSIA

KRUVENT INDUSTRIES (M) SDN. BHD.
Lot 850, Jalan Subang 7, Taman Perindustrian Subang,
47500, Subang Jaya, Selangor D.E.
Tel: +603 80743399 Fax: +603 80743388
Email: mktg@kruger.com.my

PHILIPPINES

KRUGER M & E INDUSTRIES CORPORATION
B3 Welborne Industrial Park Bancal Carmona Cavite
4116, Philippines
Tel: +63-2-7 6223260 * +63-46 4129652
HP: +63 925 8018444
Email: mktg@krugerph.net



A member of



CNo.-CAT028.E2 JULY 2023