

Inline Fans

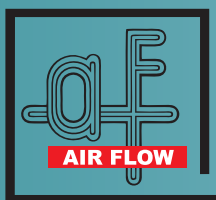

An ISO 9001:2008 Company

AFMI



An ISO 9001:2008 Company

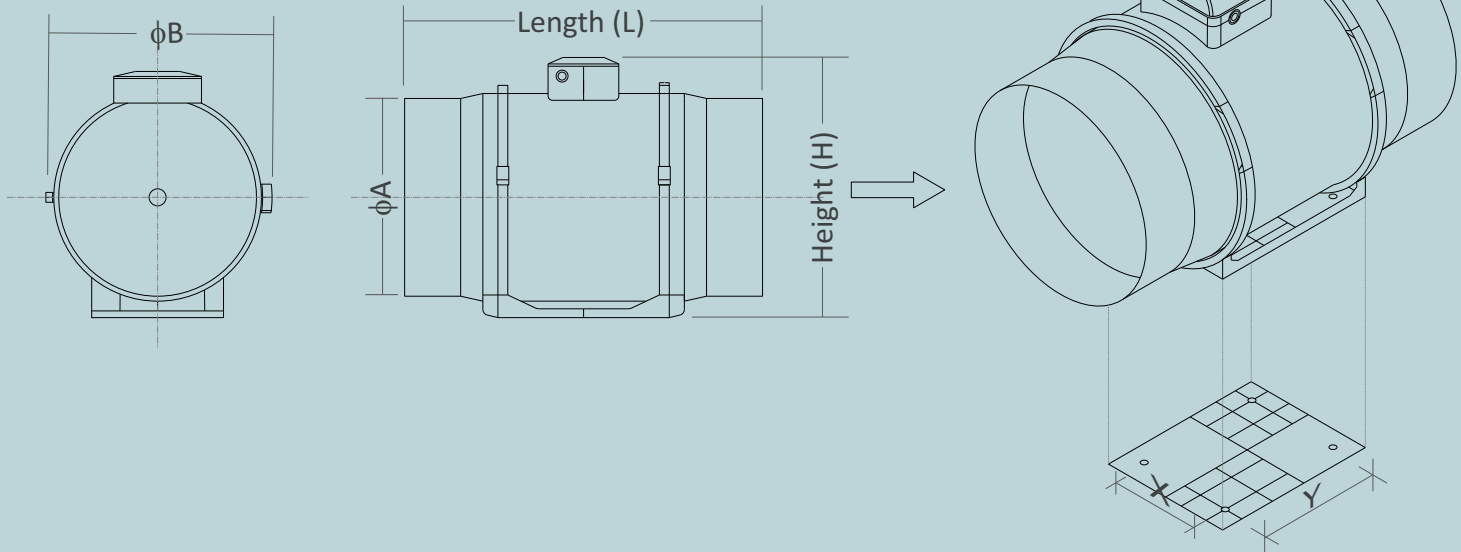

Fan Model	Fan Dia (mm)	Motor Power (watts)	φA (mm)	φB (mm)	H (mm)	L (mm)	X	Y
AFMI 125	125mm	40W	121	192	225	250	60	80
AFMI 150	150mm	65W	146	215	250	310	60	80
AFMI 200	200mm	100W	197	243	270	310	60	112
AFMI 250	250mm	235W	245	276	320	375	140	230
AFMI 315	308mm	335W	308	343	400	450	195	270

Dimension are in mm





An ISO 9001:2008 Company

Company Profile

We “Efforts combined with a sincere selfless commitment and continuous pursuance of excellence Translate into Success;”

At Air Flow, these 4 decades of existence have been an endless process of attaining ‘Success’ with enhancing capabilities, consolidating commitment and cementing faith in quality and innovation. Right from the inception in 1973, we have been leaders in manufacturing , Exporting and importing Air Terminal Products, Air Distribution Products, Smoke/Fire Damper, Jet Fans Axial Flow Fans, Vane Axial Flow, Plug Fans, Centrifugal Fans, Flexible Duct Connectors, Jet Nozzles and Louvers through this long duration of time. The way we’re empowering our product line and winning laurels from our clients world over by continuously improving upon our existing set on skills, technology, and range, we are poised to set more and more landmarks globally in the future.

Being in the good books of architects, consultants, contractors and builders is one of the key assets we cherish from the core of our heart. Yet again, it’s the idea of giving this best and always raising the bar of standards high that propel us towards accomplishing what many think impossible. Fire Rating for Axial Flow Fans & Jet Fans, truly stands the acknowledgment of the most powerful characteristic of the Company as ever.

Not only did we set new benchmarks in achieving the Exova for our Axial Flow Fans, we happen to be the sole manufacturers of the one of a kind UL Listed Axial Flow fans in the Aisa Certified by Underwriters Laboratories in accordance with UL-705. Now-a-days, the UL Fans has become important part of basement ventilation.

Air Flow has a team of hard core professionals who believe in ‘ just make it happen’ Our tremendous growth over the year speaks volumes about our professional integrity and never-say–die spirit. Surely, at Air Flow we understand the importance of staying self-motivated and determined to make a difference through what we do’



An ISO 9001:2008 Company

Introduction



Air Flow Pvt. Ltd. certifies that the Inline Fans AFMI-150, AFMI-250, AFMI-315 (page 14 to page16) shown herein are licensed to bear the AMCA Seal. The ratings shown are based on tests and procedures performed in accordance with AMCA publication 211 and AMCA Publication 311 and comply with the requirements of the AMCA Certified Ratings Program.

Design

The fan casing is made of high quality and durable materials: ABS plastic for the “Air Flow - AFMI” series which is low flammable polypropylene.

The removable impeller and motor block with a terminal box is fixed to the casing assembled with the spigots by means of special clamps with latches. This makes the fan maintenance fast and easy. The fan maintenance does not require total disassembling. Just pull out the central block from the casing and perform required servicing.

The Removable Body with the junction box can be rotated 180° to Facilitate Mounting and Wiring. The inlet spigot is equipped with a collector to enable smooth air inlet to the fan. The hemispheric impeller shape and specially profiled blades increase the air flow circular velocity and provide higher pressure and capacity as compared to standard axial fans. The diffuser, the specially profiled impeller and the directing vanes at outlet from the fan casing distribute air flow in such a way as to attain the best combination of high performance, enhanced pressure and low noise.

Motor

These Fan models are equipped with a single phase motor and are available in two speed modifications, with low energy demand. The motors have thermal overheating protection to prevent the motor overload. The ball bearings extend the motor service life up to 40000 hrs at non-stop operation. The motor has IPX4 ingress protection rating.

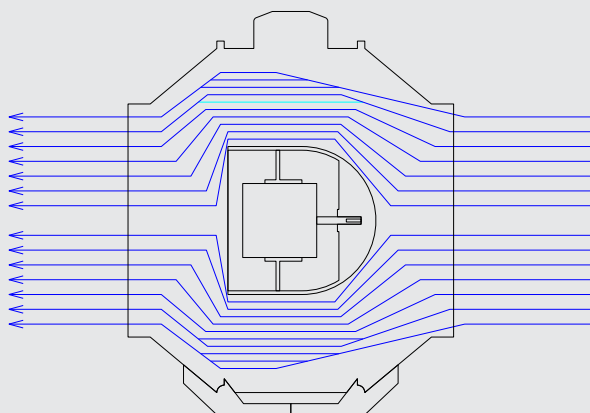



An ISO 9001:2008 Company

Application

The “Air Flow Mixed Flow Inline Fans” are featured with wide capabilities and high performance of axial and centrifugal fans and are specifically designed for supply and exhaust ventilation of premises requiring high pressure, powerful air flow and low noise level. The fans are compatible with round air ducts from \varnothing 100 to 315 mm. The inline fans are designed to provide supply and exhaust ventilation for residential and commercial premises with limited space and proved to be best solution for some Ventilation systems based on these fans are as follows:

- Living rooms
- Bedrooms
- Bathrooms
- Business offices
- Conference rooms
- Lunch break rooms
- Smoking rooms
- Libraries, etc.

Mounting

The fans are suitable for mounting at any angle and point of the system. Several fans may be installed inside one system. Several fans may be installed inside one system:

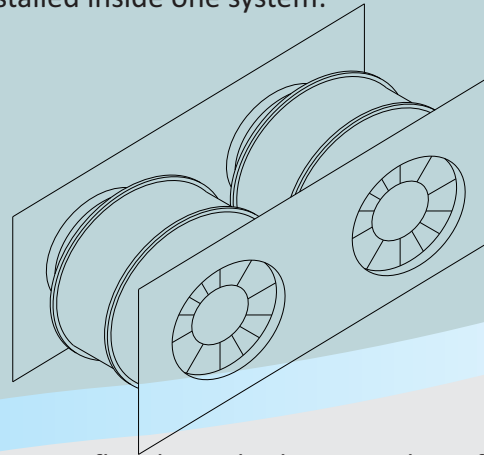

Parallel mounting to increase flow by multiplying number of Fans for same pressure

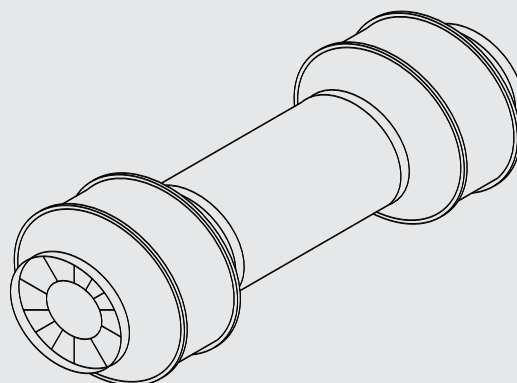

Series mounting to increase operating pressure by multiplying number of Fans same flow



An ISO 9001:2008 Company

The fan case is equipped with a flat mounting plate to attach the fan to the wall. The mounting box may be installed in any position to facilitate mounting and wiring.

Salient features

- High performance
- Low noise
- Energy efficient
- Compact size
- Wide variety sizes
- Installation at any angle
- Easy mounting
- Simple electric connection and servicing
- Great variety fans for ventilation in various premises.

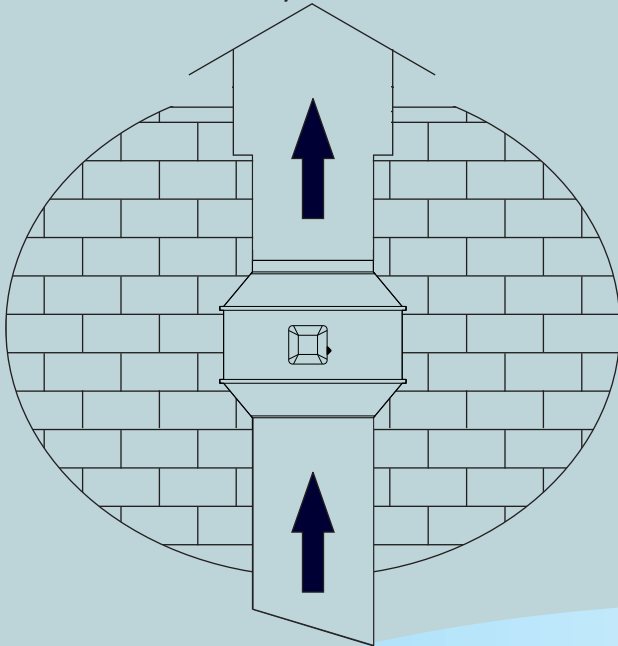

Vertical Wall fitting

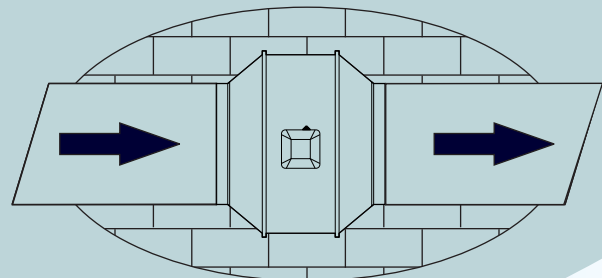

Horizontal Wall Fitting

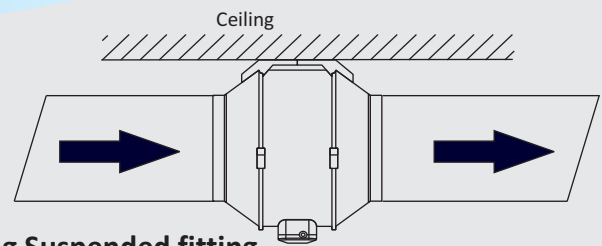

Ceiling Suspended fitting

System Effects

Factors affecting Air Performance

System Effect: A pressure loss which recognizes the effect of fan inlet restrictions, fan outlet restrictions or other conditions influencing fan performance when installed in the system. Duct elbows, transitions or other disruptions to uniform airflow may contribute to system effect, by the proximity to walls, beams and other obstruction to air flow in case of unducted fans. For a quantitative discussion of system effects refer to AMCA Publication 201 - Fans and Systems.

The diagram below shows some more common causes of system effect.

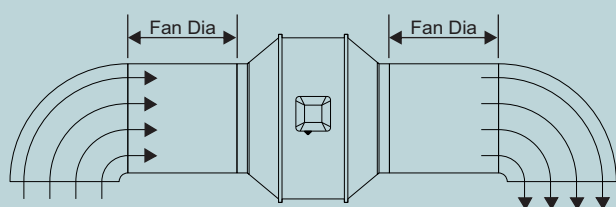

Good
(Fan Inlet & Outlet bends connected after Fan dia distance)

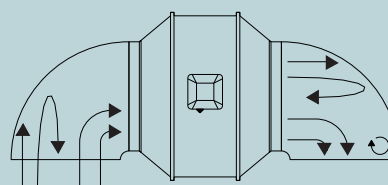

Poor
(Fan Inlet or/and Outlet bends connected immediately at Fan, may even leads to Impeller, bearing or Motor damage, system may demand excessive pressure for desired air quantity)

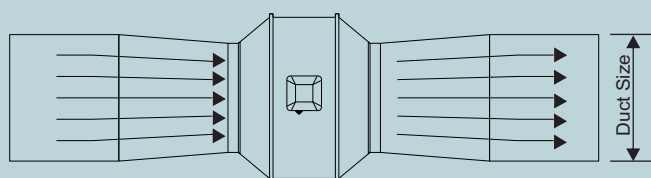

Good
(Duct Size greater than Fan Inlet)

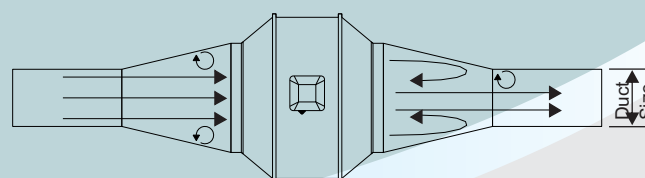

Poor
(Duct Size smaller than Fan Inlet or/and Fan Outlet connected immediately at Fan, may even leads to Impeller, bearing or Motor damage, system may demand excessive pressure for desired air quantity)

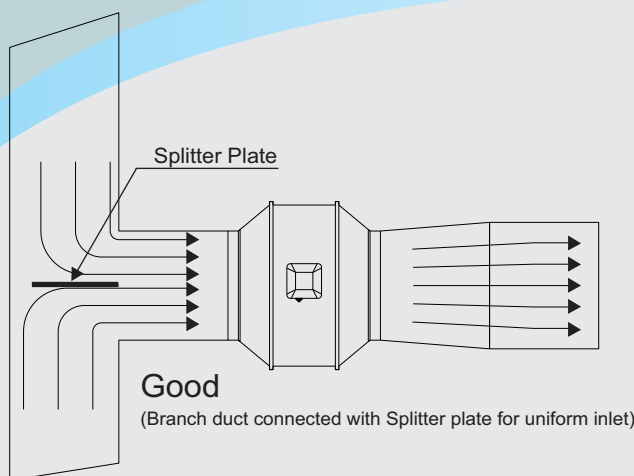

Good
(Branch duct connected with Splitter plate for uniform inlet)

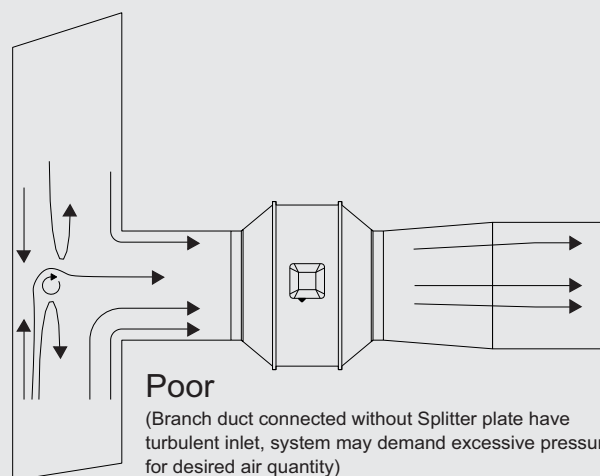

Poor
(Branch duct connected without Splitter plate have turbulent inlet, system may demand excessive pressure for desired air quantity)

*Installation of Fan with "Poor" condition ducting, may leads to impeller damage, bearing damage, low Air quantity flow, excessive power consumption, turbulent noise, lower Fan life



An ISO 9001:2008 Company

Fan Laws

$$CMH_2 = CMH_1 \times \left(\frac{RPM_2}{RPM_1}\right)^1 \times \left(\frac{D_2}{D_1}\right)^3 \times \left(\frac{d_2}{d_1}\right)^0$$

$$SP_2 = SP_1 \times \left(\frac{RPM_2}{RPM_1}\right)^2 \times \left(\frac{D_2}{D_1}\right)^2 \times \left(\frac{d_2}{d_1}\right)^1$$

$$BKW_2 = BKW_1 \times \left(\frac{RPM_2}{RPM_1}\right)^3 \times \left(\frac{D_2}{D_1}\right)^5 \times \left(\frac{d_2}{d_1}\right)^1$$

CMH - Air quantity in Cubic Meter per Hour

SP - Static Pressure in mm WG

BKW - Fan Brake Kilowatt

RPM - Fan revolution per minute

D - Fan diameter

d - Density of air Standard air density = 1.2kg/m³

At higher than standard elevations and temperatures, air density will be lower than standard.

1 - Initial State

2 - Final State

To calculate:

Total Pressure = static pressure + velocity Pressure

Velocity Pressure (Pa) = ½ x d (density of air kg/m³ x (Fan Outlet velocity m/s)²

Fan outlet Velocity (m/s) = CMH ÷ Duct area (sq. mtr) ÷ 3600

Tip speed (m/s) = π x fan diameter (mtr) x fan rpm ÷ 60

Total efficiency η % = $\frac{CMS \times Total \ Pressure \ (mm \ WG)}{102 \times \ BKW}$

Velocity

Feet/Min. (fpm)	Meter/Sec (mps)	Meters/Min. (mpm)	Meters/Hr. (mph)
1.0	0.00508	0.3048	18.288
60.0	0.3038	18.228	1093.7
80.0	0.4	26.822	1609.4
196.85	1.0	60.0	3600.0
3.2808	0.0167	1.0	60.0
0.05468	0.000267	0.01667	1.0

Volume Flow Rates:

Cubic Ft./Min (CFM)	Cubic Meter/Sec. (M3/S)	Cubic Meters/Hr. (M3/Hr.)
1.0	0.000472	1.699
0.01667	0.00000787	0.02832
2118.9	1.0	3600.0
35.315	0.01667	60.0
0.58858	0.00028	1.0
2.1189	0.001	3.6

MISCELLANEOUS CONVERSION FACTORS

LENGTH

1 in = 2.54 cm
 1 ft = .348 m
 1 yd = .9144 m
 1 mi = 1.6093 km
 1 nau. mi = 1.1516 mi

AREA

1 in² = 6.4516 cm²
 1 Ft² = .0929 m²
 1 yd² = .8381 m²
 1 mi² = 2.5899 Km²

POWER

1 hp = .746 KW
 1 hp = 550 ft-lb/sec
 1 hp = 33000 ft-lb/min
 1 hp = 76.04 kg-m/sec
 1 hpm = 75.00 kg-m/sec

HEAT

1 Btu = 777.97 Ft-lb
 1 hp = 2545 Btu/hr
 1 hp = 1.014 metric hp
 1 hp = .0761 boiler hp
 1 kw = 3414 Btu/hr
 1 Ton = 12000 Btu/hr

DENSITY

1 lb/ft³ = 16.018 kg/m²

TIP SPEED

1 fpm = .0051 m/s

Asking for 90dBA Fan

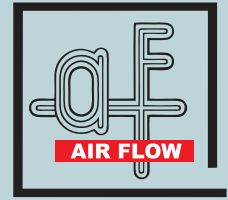

An ISO 9001:2008 Company

* Article abstract from AMCA Techspec Vol.III - No.1

Asking for 90dBA Fan is a lot like asking for a “light”, you don't know what you are going to get. The term dBA relates to sound pressure. How much sound pressure emanates from a fan depends on a number of variable. Calculate sound pressure from the fan sound power rating using unknown variables.

Comparing light levels

Most of us are much more familiar with light, If someone says he has a 100 watt light bulb you have some idea of the candlepower available. If the light bulb is frosted you know more about the available light, but if you want to read by the light, you want to know the light intensity level at the reading location. Light intensity level is expressed as foot candles, this is equivalent to sound pressure level in dB.

If you think in terms of light intensity for reading, using only light from a 100 Watt frosted light bulb, there are lot of question to be answered. Some question are:

	Question for client	Light aspect	Sound aspect
a)	How far is the Light?	If the light is the mile away it is not much use.	How far is the fan?
b)	Is the light outdoors?	With no walls, all but the direct light radiates out into “free field” of space.	Is the fan outdoors?
c)	How big is the room?	Light could reflect off all the walls of a small room.	How big is the room?
d)	Are the room walls white?	A room covered with black velvet would not reflect much light regardless of its size.	How sound absorbent are the walls?

Calculating Sound Pressure

Sound questions are very similar to the light questions. Sound instruments measure only sound pressure, this pressure varies depending on the surroundings. To calculate sound pressure from sound power, all the variables have to be considered. AMCA publication 303 Application of Sound Power Level Ratings for fan is an introduction to the complex relationship between sound power level at one location and the sound pressure level, what is heard, at a second location.

Human Response

One further complication of working with a sound is that the ear sensitivity varies with frequency. A low frequency sound of a certain power does not seem as loud as a higher frequency sound of the identical power. To account for this difference a “weighting scale” has been developed . Sound power levels adjusted by this specific weighting scale are called “A weighted”. Sound pressure levels are calculated to a single number dBA.

Free Field Ratings

Because one environment, a free field, can be easily defined it is sometimes used to specify desired sound pressure levels. If a fan is placed on the ground in a large open field all of its sound would radiate out in a hemispherical free field with no sound reflected back .These condition are fully defined and it is possible to convert fan sound power to sound pressure at a specific distance. As the distance increases the sound pressure decreases, so only sound pressure comparisons at a given distance are valid. If you specify a 90 dBA maximum fan at five feet in a hemispherical free field, it is possible to calculate dBA sound pressure from sound power rating.

When no conditions are given comparisons cannot be made. Fan A measures 90 dBA at 10 feet and a 12 dB louder fan, Fan B, measures 90 dBA at 40 feet, both in a hemispherical free field .Any fan can meet the maximum criterion if properly located.

Since few fans are used in an open field it is likely that a 90 dBA specification refers to a specific location. Much more data are needed to decide fan sound power limits which will provide a 90 dBA pressure measurement.



An ISO 9001:2008 Company

Use the Air change calculation to determine Air Quantity

What is an Air Change per hour - ACPH?

An air change is how many times the air enters and exits a room from the HVAC system in one hour. Or, how many times a room would fill up with the air from the supply registers in sixty minutes.

You can then compare the number of room air changes to the Required Air Changes Table below. If it's in the range, you can proceed to design or balance the airflow and have an additional assurance that you're doing the right thing. If it's way out of range, you'd better take another look.

The Air Changes Formula

To calculate room air changes, measure the supply airflow in CMH . Then divide by the volume of the room in cubic meter.

Air changes per hour (ACPH) = CMH/ Volume of room in cubic meter

Typical Air changes per hour			
S.no	Area type	Room type	ACPH
1.	Residential	Bedrooms	5-6
2.		Bathrooms	6-7
3.		Family living room	6-8
4.	Offices	Business offices	6-8
5.		Lunch break rooms	7-8
6.		Conference rooms	8-12
7.		Copy rooms	10-12
8.		Main computer rooms	10-14
9.		Smoking room	13-15
10.	Public buildings	Hallways	6-8
11.		Retail Stores	6-10
12.		Foyers	8-10
13.		Restrooms	10-12
14.		Smoking rooms	15-20

Calculation for room CMH = ACPH X Volume of room in cubic meter

Insufficient airflow performance of a ventilating fans are subject to factors that cause excessive pressure loss. These factors could be expressed as below:

1. "Airtight rooms", as Fan can not generate air, for supply or exhaust even a powerful fan is not able to pump in or pump out sufficient air from airtight room.
2. "Insufficient size openings", even if ventilation fan is installed, its function would not work unless a right size of inlet and /or outlet duct opening, duct cross-section size if not maintained.
3. "Pressure drop across duct", lengths, bends & duct operational air velocity and system resistance like inlet/outlet grilles, supply air path & return air path, filters, dampers, heaters etc in between system should be considered in pressure drop calculation for adequate supply.
4. "Pressure drop due to confluence" causes pressure loss by air confluence in the same duct.
5. "Outside wind pressure" is especially important in the case of high rise building.



An ISO 9001:2008 Company

AFMI- 125 @ 2650 / 2050rpm

Inlet area: 0.0113 sq. mtr. & Outlet area: 0.0113 sq. mtr

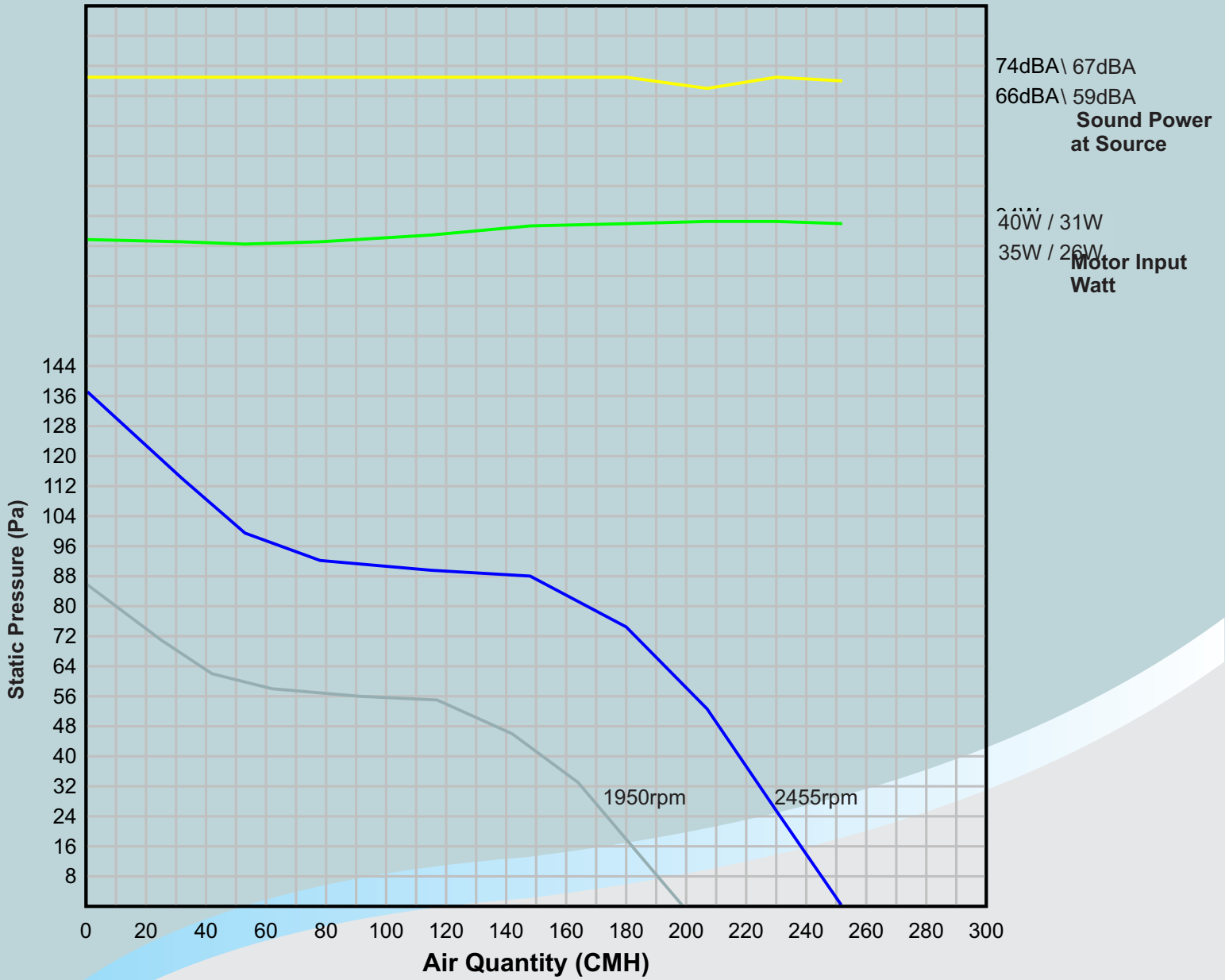

Performance is for installation type D - Ducted inlet, Ducted Outlet. Performance ratings do not include the effects of appurtenances (accessories). The A-weighted sound ratings shown have been calculated per AMCA International Standard 301. Values shown are for inlet LwiA sound power level for Installation Type D: Ducted inlet, Ducted outlet. Model: AFMI - 125 is not licensed to bear the AMCA Certified Ratings Seal.



An ISO 9001:2008 Company

AFMI- 200 @ 2500 / 1800rpm

Inlet area: 0.0290 sq. mtr & Outlet area: 0.0290 sq. mtr

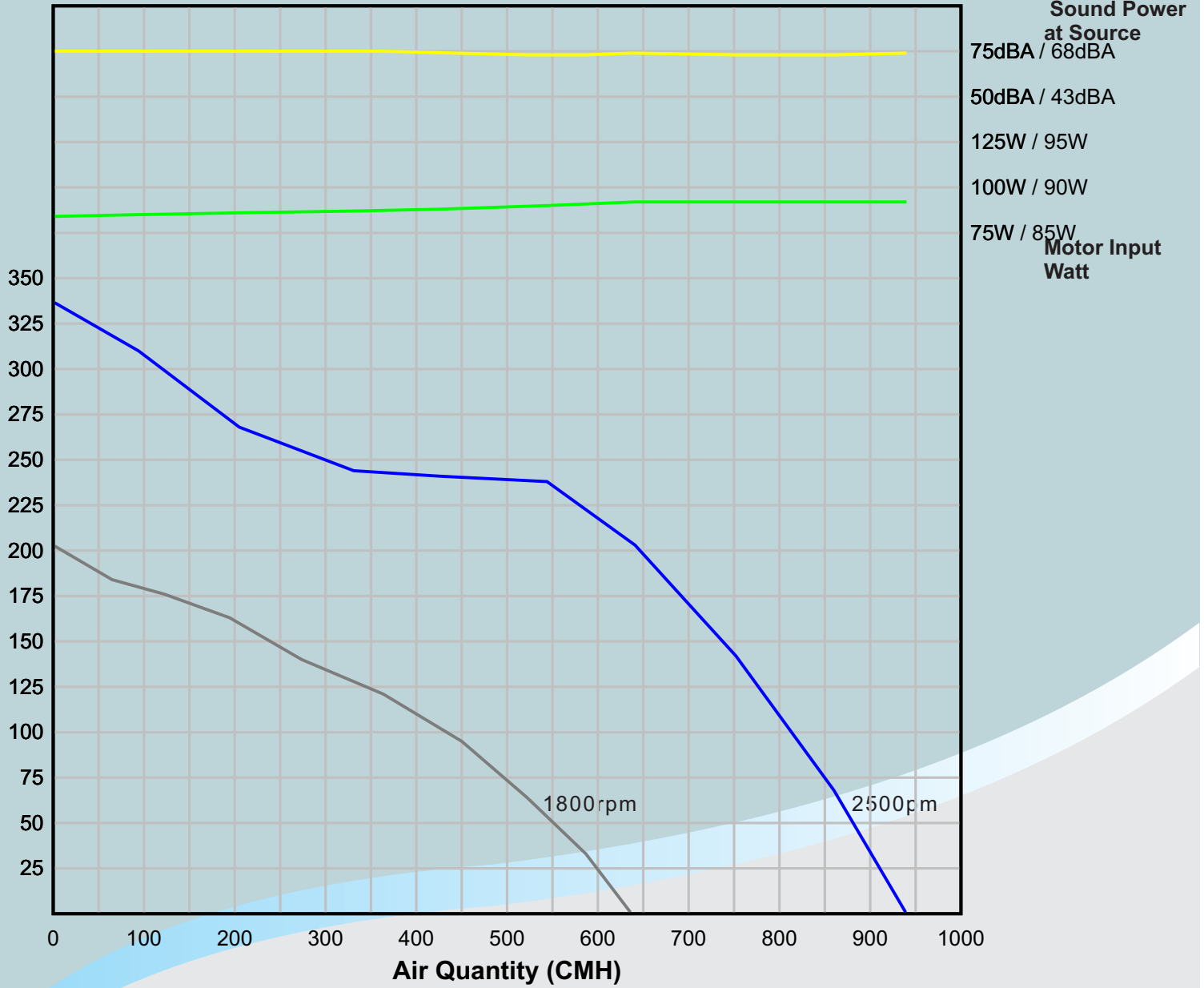

Performance is for installation type D - Ducted inlet, Ducted Outlet. Performance ratings do not include the effects of appurtenances (accessories). The A-weighted sound ratings shown have been calculated per AMCA International Standard 301. Values shown are for inlet LwiA sound power level for Installation Type D: Ducted inlet, Ducted outlet. Model: AFMI - 200 is not licensed to bear the AMCA Certified Ratings Seal.

CMH	St. Pr. (Pa)	RPM	Watt (W)	Sound Power Levels Lwi (dB)								Overall LwiA (dBA)	Loudness in Sones
				63	125	250	500	1000	2000	4000	8000		
940	0	2421	133	79	86	72	68	65	66	63	54	74	9.6
860	68	2425	132	78	86	72	66	64	64	61	54	73	8.8
752	142	2452	129	79	86	71	65	63	64	61	55	73	8.6
544	238	2421	118	81	84	80	71	65	66	61	55	75	9.9



AFMI-150 @ 2520rpm

Inlet area: 0.0158 sq. mtr & Outlet area: 0.0158 sq. mtr

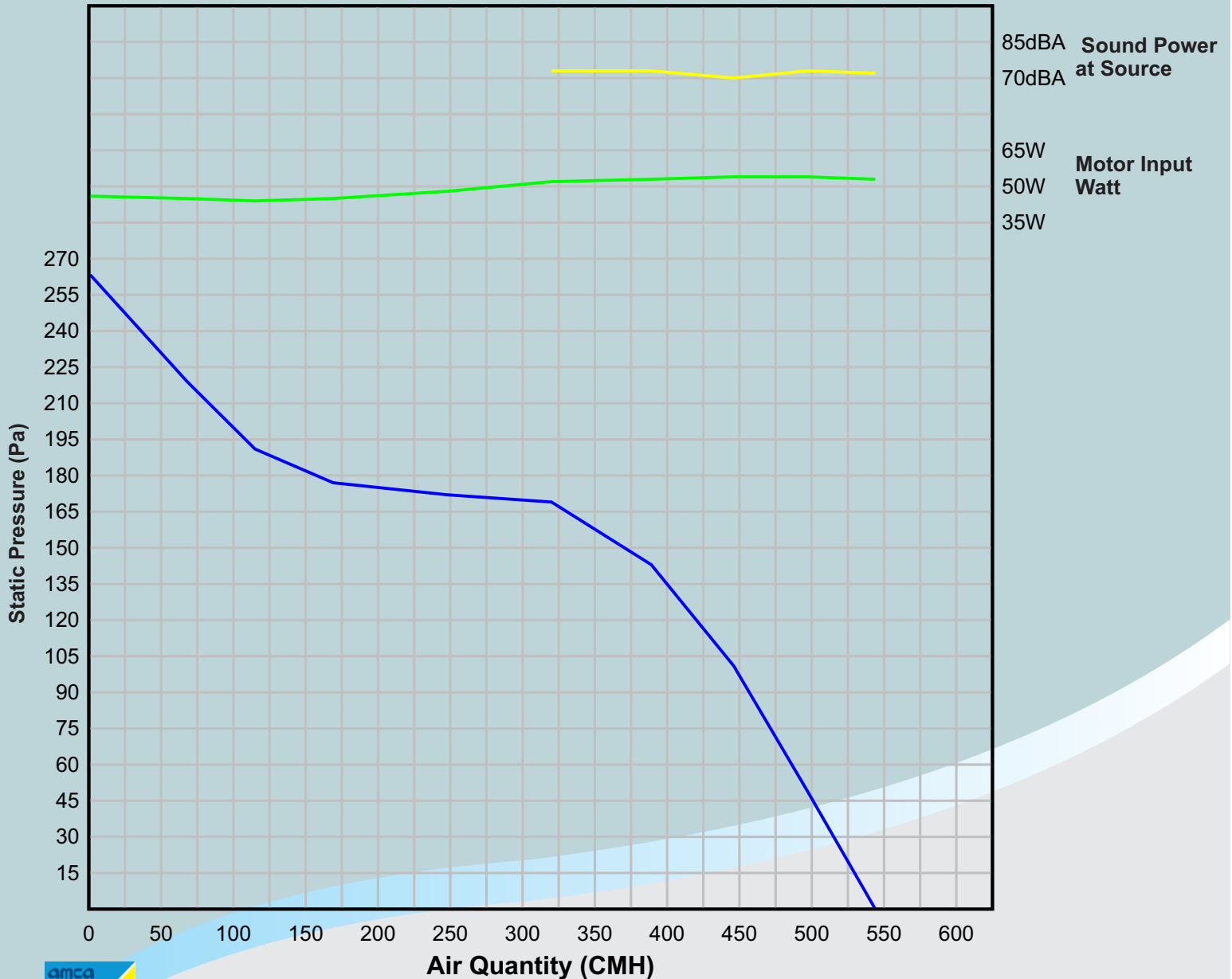

Air Flow Private Limited certifies that the Inline Fan series AFMI-150 shown herein are licensed to bear the AMCA Seal. The ratings shown are based on tests and procedures performed in accordance with AMCA Publication 211 and AMCA Publication 311 and comply with the requirements of the AMCA Certified Ratings Program. Speed (RPM) shown is nominal. Performance is based on actual speed of test.

Performance certified is for installation type D - Ducted inlet, Ducted Outlet. Performance ratings do not include the effects of appurtenances (accessories). The A-weighted sound ratings shown have been calculated per AMCA International Standard 301. Values shown are for inlet Lwi and inlet LwiA sound power levels for Installation Type D: Ducted inlet, Ducted outlet. Ratings include the effects of duct end correction.

CMH	St. Pr. (Pa)	RPM	Watt (W)	Sound Power Levels Lwi (dB)								Overall LwiA (dBA)	Loudness in Sones
				63	125	250	500	1000	2000	4000	8000		
544	0	2514	53	78	74	77	68	63	62	58	52	72	7.7
497	49	2491	54	79	73	79	68	61	61	56	51	72	7.5
446	101	2473	54	77	76	73	67	61	59	54	49	69	6.5
320	169	2557	52	79	74	79	70	62	58	55	49	73	7.1

The sound ratings shown are loudness values in fan sones at a distance of 1.5m (5ft) in a hemispherical free field calculated per AMCA International Standard 301, Values shown are for installation Type D: Ducted inlet hemispherical sone levels. Ratings do not include the effect of duct end correction



An ISO 9001:2008 Company

AFMI-250 @ 2400rpm

Inlet area: 0.047 sq. mtr & Outlet area: 0.047 sq. mtr

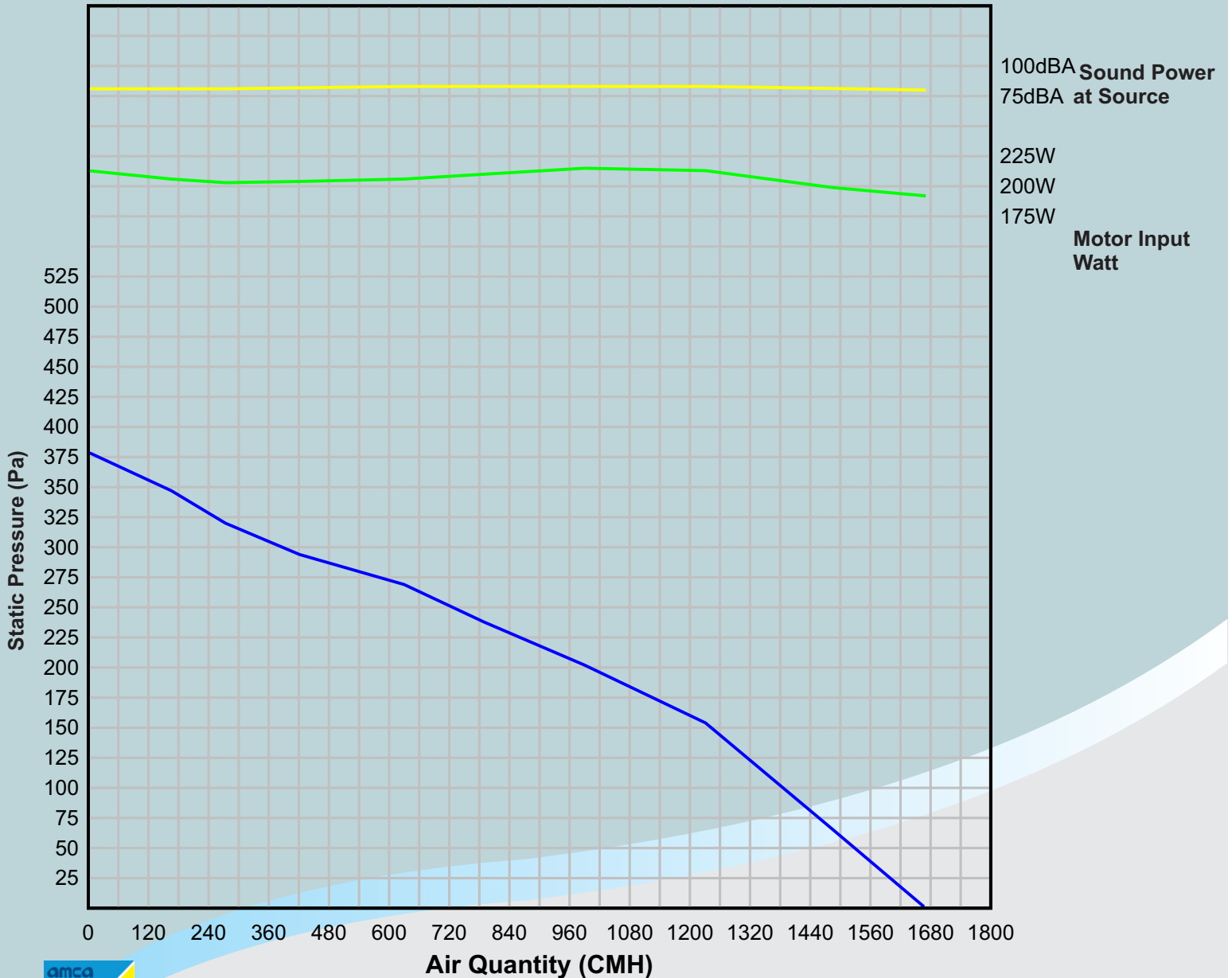

Air Flow Private Limited certifies that the Inline Fan series AFMI-250 shown herein are licensed to bear the AMCA Seal. The ratings shown are based on tests and procedures performed in accordance with AMCA Publication 211 and AMCA Publication 311 and comply with the requirements of the AMCA Certified Ratings Program. Speed (RPM) shown is nominal. Performance is based on actual speed of test.

Performance certified is for installation type D - Ducted inlet, Ducted Outlet. Performance ratings do not include the effects of appurtenances (accessories). The A-weighted sound ratings shown have been calculated per AMCA International Standard 301. Values shown are for inlet Lwi and inlet LwiA sound power levels for Installation Type D: Ducted inlet, Ducted outlet. Ratings include the effects of duct end correction.

CMH	St. Pr. (Pa)	RPM	Watt (W)	Sound Power Levels Lwi (dB)								Overall LwiA (dBA)	Loudness in Sones
				63	125	250	500	1000	2000	4000	8000		
1670	0	2555	192	78	95	75	76	72	70	64	56	80	12.3
1274	142	2429	210	77	92	90	78	73	69	62	56	83	14.6
702	256	2454	208	84	93	90	79	73	70	65	59	83	15.3
238	328	2494	202	92	93	85	76	73	69	65	60	81	13.6

The sound ratings shown are loudness values in fan sones at a distance of 1.5m (5ft) in a hemispherical free field calculated per AMCA International Standard 301, Values shown are for installation Type D: Ducted inlet hemispherical sone levels. Ratings do not include the effect of duct end correction



AFMI-315@ 2400rpm

Inlet area: 0.0702 sq.mtr & Outlet area: 0.0702 sq.mtr

An ISO 9001:2008 Company

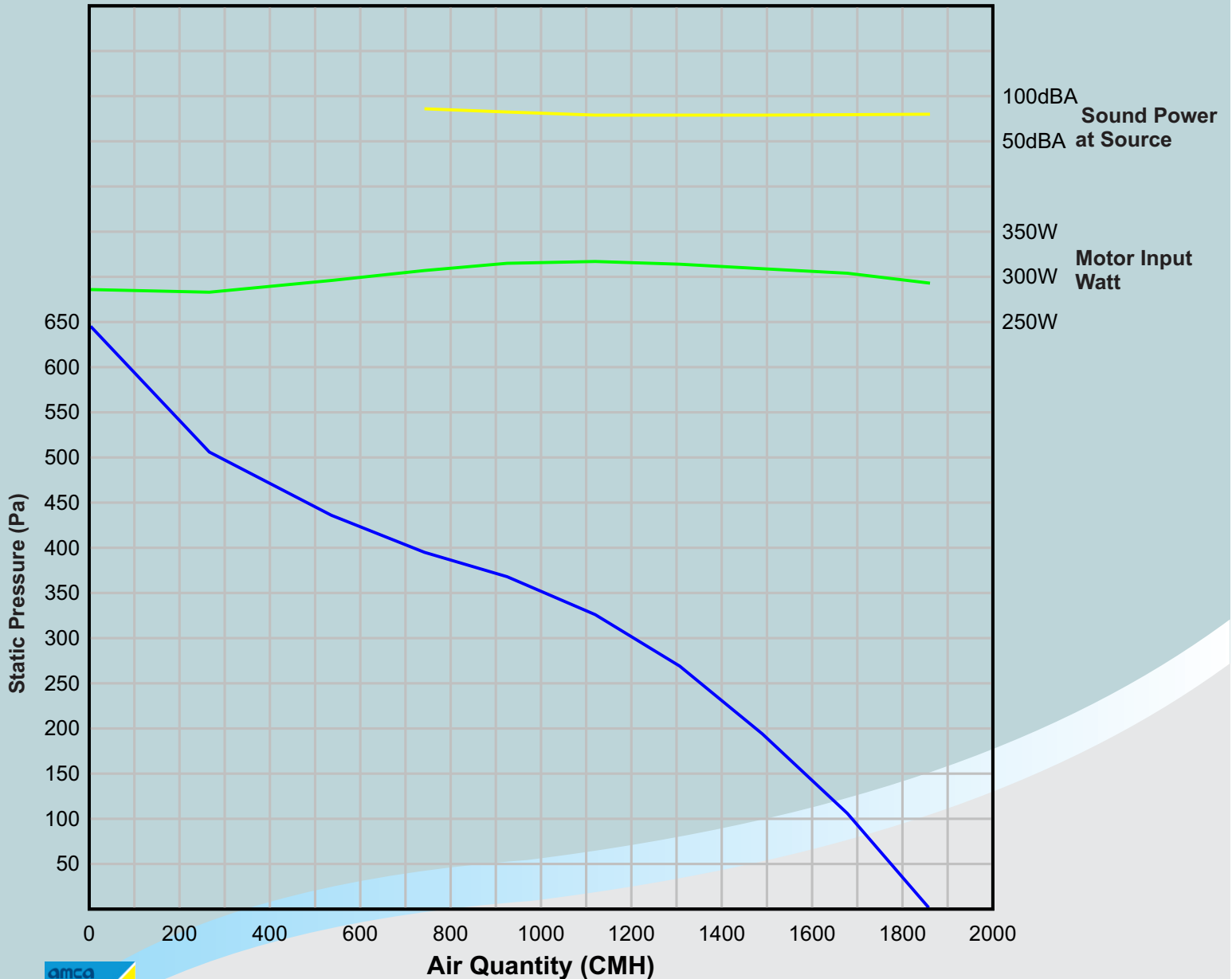





Air Flow Private Limited certifies that the Inline Fan series AFMI-315 shown herein are licensed to bear the AMCA Seal. The ratings shown are based on tests and procedures performed in accordance with AMCA Publication 211 and AMCA Publication 311 and comply with the requirements of the AMCA Certified Ratings Program. Speed (RPM) shown is nominal. Performance is based on actual speed of test.

Performance certified is for installation type D - Ducted inlet, Ducted Outlet. Performance ratings do not include the effects of appurtenances (accessories). The A-weighted sound ratings shown have been calculated per AMCA International Standard 301. Values shown are for inlet Lwi and inlet LwiA sound power levels for Installation Type D: Ducted inlet, Ducted outlet. Ratings include the effects of duct end correction.

CMH	St. Pr. (Pa)	RPM	Watt (W)	Sound Power Levels Lwi (dB)								Overall LwiA (dBA)	Loudness in Sones
				63	125	250	500	1000	2000	4000	8000		
1861	0	2504	293	73	81	74	74	77	73	69	63	80	14.8
1490	194	2357	309	72	81	75	75	75	71	66	59	78	13.6
1120	326	2275	317	75	81	84	74	74	69	63	58	79	13.0
742	395	2333	307	82	96	92	78	75	71	65	59	86	18.0

The sound ratings shown are loudness values in fan sones at a distance of 1.5m (5ft) in a hemispherical free field calculated per AMCA International Standard 301, Values shown are for installation Type D: Ducted inlet hemispherical sone levels. Ratings do not include the effect of duct end correction

Easy Installation Procedure:	
Fix the fan mounting plate on the flat surface.	
Install the removable body inside the fan case.	
Lock the removable body by clamps with latches.	
Secure latches by screws.	
Attach the ducts with clamps	
Insert the plug into electrical socket - the fan is READY to GO!	
Select a required speed by built-in speed switch. ENJOY the FRESH AIR.	
Forget about dismantling! Just remove the central body from the case and complete the servicing!	

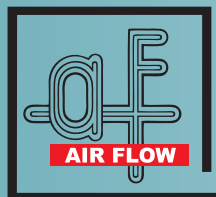

An ISO 9001:2008 Company

AIR FLOW PVT. LTD.

H123, J-90 & 91, Site-5, Kasna, Greater Noida,
Surajpur Industrial Area, Uttar Pradesh, India - 201310

Phone: +91-1147602222, 28751236

email: mail@airflow.in, sales@airflow.in

www.airflow.in; <https://facebook.com/airflowindia>

Catalogue reference - AFPL:A57: C24 December 2025