

EME520DDE

Wind-Driven Rain Resistant Stationary Louver
High Performance Extruded Aluminum Construction
AMCA Certified and Florida Building Code Approved



APPLICATION

The EME520DDE is 5" deep, mechanically fastened, extruded aluminum, double drainable, horizontal, stationary louver designed to protect air intake and exhaust openings in exterior walls. This louver offers exceptional protection against wind-driven rain under the most severe conditions. This louver is designed with a drainable gutter system that channels water from the blades to downspouts in the jambs. Here, water is exhausted out of the front of the louver.

STANDARD CONSTRUCTION

Frame	5" (127) deep, 6063T6 extruded aluminum with .081" (2.1) nominal wall thickness.
Blades	6063T6 extruded aluminum .060" (1.5) nominal wall thickness. Double drainable blades are sightproof and spaced approximately 2" (51) center to center.
Screen	5/8" x .040" (16 x 1) expanded, flattened aluminum bird screen in removable frame. Screen adds approximately 1/2" (13) to louver depth.
Finish	Mill
Approximate Shipping Weight	7 lbs. per sq. ft. (34.2 kg/m ²)
Minimum Size	12"w x 12"h (305 x 305)
Maximum Factory Assembly Size	Single sections shall not exceed 120" x 90"h (3048 x 2286) or 90"w x 120"h (2286 x 3048). Louvers larger than the maximum single section size will require field assembly of smaller sections.
Supports	Louvers may be provided with rear mounted blade supports that increase overall louver depth depending on louver size, assembly configuration or windload.

FEATURES

- ▶ Closely spaced horizontal blades minimize the penetration of wind-driven rain, reducing damage and additional operating expenses.
- ▶ Published performance ratings based on testing in accordance with AMCA Publication 511.
- ▶ 47% Free Area.
- ▶ Beginning point of water penetration at .01 oz. /sq. ft. is above 1250 fpm (381 m/min).
- ▶ FBC #22554.1
- ▶ AMCA 540 Listed (Enhanced Protection).
- ▶ AMCA550 Listed for High Velocity Wind Driven Rain with Damper.

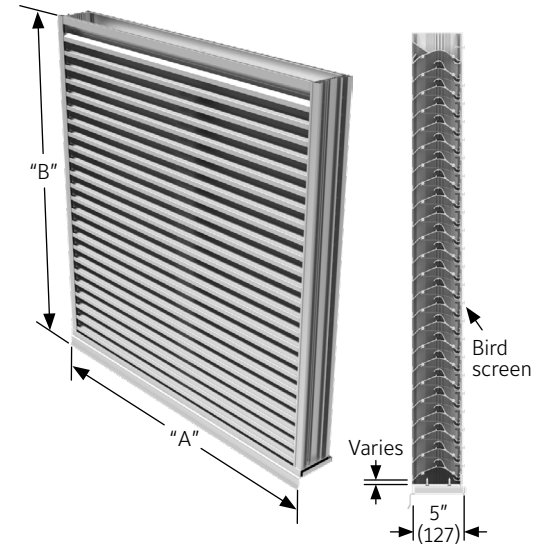

VARIATIONS

- ▶ Extended sill.
- ▶ Hinged frame.
- ▶ Front or rear security bars.
- ▶ Filter racks.
- ▶ Installation angles.
- ▶ A variety of bird and insect screens.
- ▶ Front Flange Frame and Sleeve required when combo AMCA550 option is chosen.
- ▶ Please provide rough opening dimensions for "A" and "B" dimensions. unless ordered as actual size, the louver will be provided 1/2" (12) smaller than "A" and "B" dimensions provided.
- ▶ Optional finishes available at additional cost: Prime coat, 50% PVDF (modified fluoropolymer), Epoxy, Pearledize, 70% PVDF, Clear and Anodized finishes. (Some variation in anodize color consistency is possible).

Consult Ruskin for other special requirements.

NOTE:

1. Dimensions in inches, parenthesis () indicate millimeters.
2. Units furnished 1/4" (6) smaller than given opening dimensions.

PERFORMANCE DATA



**HIGH VELOCITY
RAIN RESISTANT
WITH BLADES FULLY CLOSED**

See www.AMCA.org for all certified or listed products

This label does not signify
AMCA airflow performance
certification.

Ruskin certifies that the EME520DDE shown herein is approved to bear the AMCA Listing Label. The ratings shown are based on tests and procedures performed in accordance with AMCA Publications and comply with the requirements of the AMCA Listing Label Program.



**IMPACT
RESISTANT
LOUVER
Enhanced Protection Level E**

See www.AMCA.org for all certified or listed products

This label does not signify
AMCA airflow performance
certification.

The AMCA Listing Label applies to wind Born Debris Impact Resistant and High Velocity Wind Driven Rain Resistant Louvers (with optional CD40, CD50 or SD60 damper in the closed position)

FREE AREA GUIDE

Free Area Guide shows free area in ft² and m² for various sizes of EME520DDE.

Width – Inches and Meters

HEIGHT	12	18	24	30	36	42	48	54	60	66	72	78	84	90	96	102	108	114	120
	0.30	0.45	0.60	0.75	0.90	1.05	1.20	1.35	1.50	1.65	1.80	1.95	2.10	2.25	2.40	2.55	2.70	2.85	3.00
12 0.30	0.28 0.03	0.45 0.04	0.62 0.06	0.80 0.07	0.97 0.09	1.14 0.11	1.32 0.12	1.49 0.14	1.66 0.15	1.83 0.17	2.01 0.19	2.18 0.20	2.35 0.22	2.53 0.23	2.70 0.25	2.87 0.27	3.05 0.28	3.22 0.30	3.39 0.32
18 0.45	0.49 0.05	0.79 0.07	1.09 0.10	1.40 0.13	1.70 0.16	2.00 0.19	2.31 0.21	2.61 0.24	2.91 0.27	3.22 0.30	3.52 0.33	3.82 0.36	4.13 0.38	4.43 0.41	4.73 0.44	5.04 0.47	5.34 0.50	5.64 0.52	5.94 0.55
24 0.60	0.70 0.06	1.13 0.10	1.56 0.15	2.00 0.19	2.43 0.23	2.86 0.27	3.30 0.31	3.73 0.35	4.16 0.39	4.60 0.43	5.03 0.47	5.46 0.51	5.90 0.55	6.33 0.59	6.76 0.63	7.20 0.67	7.63 0.71	8.06 0.75	8.50 0.79
30 0.75	0.90 0.08	1.47 0.14	2.03 0.19	2.60 0.24	3.16 0.29	3.72 0.35	4.29 0.40	4.85 0.45	5.41 0.50	5.98 0.56	6.54 0.61	7.11 0.66	7.67 0.71	8.23 0.77	8.80 0.82	9.36 0.87	9.92 0.92	10.49 0.98	11.05 1.03
36 0.90	1.11 0.10	1.81 0.17	2.50 0.23	3.20 0.30	3.89 0.36	4.58 0.43	5.28 0.49	5.97 0.56	6.67 0.62	7.36 0.68	8.05 0.75	8.75 0.81	9.44 0.88	10.14 0.94	10.83 1.01	11.52 1.07	12.22 1.14	12.91 1.20	13.61 1.27
42 1.05	1.32 0.12	2.15 0.20	2.97 0.28	3.79 0.35	4.62 0.43	5.44 0.51	6.27 0.58	7.09 0.66	7.92 0.74	8.74 0.81	9.56 0.89	10.39 0.97	11.21 1.04	12.04 1.12	12.86 1.20	13.69 1.27	14.51 1.35	15.33 1.43	16.16 1.50
48 1.20	1.60 0.15	2.60 0.24	3.60 0.33	4.59 0.43	5.59 0.52	6.59 0.61	7.59 0.71	8.59 0.80	9.58 0.89	10.58 0.98	11.58 1.08	12.58 1.17	13.58 1.26	14.57 1.36	15.57 1.45	16.57 1.54	17.57 1.63	18.57 1.73	19.56 1.82
54 1.35	1.81 0.17	2.94 0.27	4.07 0.38	5.19 0.48	6.32 0.59	7.45 0.69	8.58 0.80	9.71 0.90	10.84 1.01	11.96 1.11	13.09 1.22	14.22 1.32	15.35 1.43	16.48 1.53	17.60 1.64	18.73 1.74	19.86 1.85	20.99 1.95	22.12 2.06
60 1.50	2.02 0.19	3.28 0.30	4.54 0.42	5.79 0.54	7.05 0.66	8.31 0.77	9.57 0.89	10.83 1.01	12.09 1.12	13.34 1.24	14.60 1.36	15.86 1.48	17.21 1.59	18.38 1.71	19.64 1.83	20.89 1.94	22.15 2.06	23.41 2.18	24.67 2.29
66 1.65	2.23 0.21	3.62 0.34	5.00 0.47	6.39 0.59	7.78 0.72	9.17 0.85	10.56 0.98	11.95 1.11	13.34 1.24	14.73 1.37	16.11 1.50	17.50 1.63	18.89 1.76	20.28 1.89	21.67 2.02	23.06 2.14	24.45 2.27	25.83 2.40	27.22 2.53
72 1.80	2.44 0.23	3.96 0.37	5.47 0.51	6.99 0.65	8.51 0.79	10.03 0.93	11.55 1.07	13.07 1.22	14.59 1.36	16.11 1.50	17.63 1.64	19.14 1.78	20.66 1.92	22.18 2.06	23.70 2.20	25.22 2.35	26.74 2.49	28.26 2.63	29.78 2.77
78 1.95	2.72 0.25	4.41 0.41	6.10 0.57	7.79 0.72	9.49 0.88	11.18 1.04	12.87 1.20	14.56 1.35	16.26 1.51	17.95 1.67	19.64 1.83	21.33 1.98	23.03 2.14	24.72 2.30	26.41 2.46	28.10 2.61	29.80 2.77	31.49 2.93	33.18 3.09
84 2.10	2.92 0.27	4.75 0.44	6.57 0.61	8.39 0.78	10.32 0.95	12.04 1.12	13.86 1.29	15.68 1.46	17.51 1.63	19.33 1.80	21.15 1.97	22.98 2.14	24.80 2.31	26.62 2.48	28.44 2.65	30.27 2.81	32.09 2.98	33.91 3.15	35.74 3.32
90 2.25	3.13 0.29	5.09 0.47	7.04 0.65	8.99 0.84	10.95 1.02	12.90 1.20	14.85 1.38	16.80 1.56	18.76 1.74	20.71 1.93	22.66 2.11	24.62 2.29	26.57 2.47	28.52 2.65	30.48 2.83	32.43 3.02	34.38 3.20	36.54 3.38	38.29 3.56
96 2.40	3.34 0.31	5.43 0.50	7.51 0.70	9.59 0.89	11.68 1.09	13.76 1.28	15.84 1.47	17.93 1.67	20.01 1.86	22.09 2.05	24.18 2.25	26.26 2.44	28.34 2.64	30.43 2.83	32.51 3.02	34.59 3.22	36.68 3.41	38.76 3.60	40.84 3.80
102 2.55	3.55 0.33	5.76 0.54	7.98 0.74	10.19 0.95	12.41 1.15	14.62 1.36	16.83 1.57	19.05 1.77	21.26 1.98	23.47 2.18	25.69 2.39	27.90 2.59	30.11 2.80	32.33 3.01	34.54 3.21	36.75 3.42	38.97 3.62	41.18 3.83	43.40 4.04
108 2.70	3.76 0.35	6.10 0.57	8.45 0.79	10.79 1.00	13.14 1.22	15.48 1.44	17.82 1.66	20.17 1.88	22.51 2.09	24.85 2.31	27.20 2.53	29.54 2.75	31.89 2.97	34.23 3.18	36.57 3.40	38.92 3.62	41.26 3.84	43.61 4.06	45.95 4.27
114 2.85	4.04 0.38	6.56 0.61	9.07 0.84	11.59 1.08	14.11 1.31	16.63 1.55	19.14 1.78	21.66 2.01	24.18 2.25	26.70 2.48	29.21 2.72	31.73 2.95	34.25 3.19	36.77 3.42	39.28 3.65	41.80 3.89	44.32 4.12	46.84 4.36	49.35 4.59
120 3.00	4.25 0.40	6.90 0.64	9.54 0.89	12.19 1.13	14.84 1.38	17.49 1.63	20.13 1.87	22.78 2.12	25.43 2.36	28.08 2.61	30.72 2.86	33.37 3.10	36.02 3.35	38.67 3.60	41.32 3.84	43.96 4.09	46.61 4.33	49.26 4.58	51.91 4.83

WATER PENETRATION GRAPH

AMCA Standard 500 provides a reasonable basis for testing and rating louvers. Testing to AMCA 500-L is performed under a certain set of laboratory conditions. This does not guarantee that other conditions will not occur in the actual environment where louvers must operate.

The louver system should be designed with a reasonable safety factor for louver performance. To ensure protection from water carryover design with a performance level somewhat below maximum desired pressure drop and .01 oz./sq. ft. of water penetration.



Ruskin Company certifies that the EME520DDE is licensed to bear the AMCA Seal. The ratings shown are based on tests and procedures performed in accordance with AMCA Publication 511 and comply with the requirements of the AMCA Certified Ratings Program. The AMCA Certified Ratings Seal applies to air performance ratings, water penetration ratings, and wind driven rain ratings only.

Test size 48" wide X 48" high (1219 X 1219)
Beginning point of water penetration at .01 oz. /sq. ft. is above 1250 fpm (381 m/min).

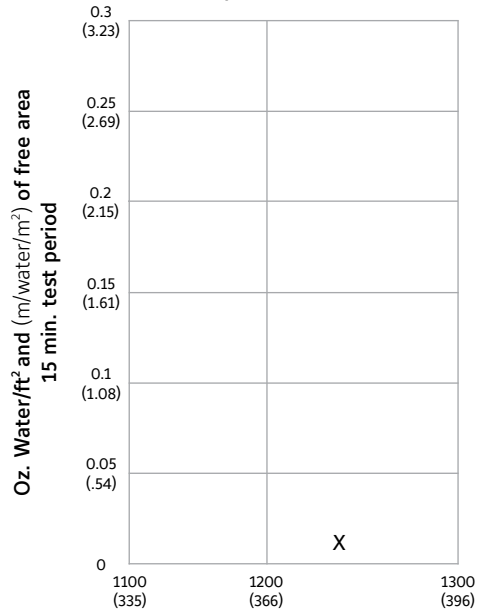

PRESSURE DROP

Pressure Drop testing performed on 48" x 48" (1219 x 1219) unit

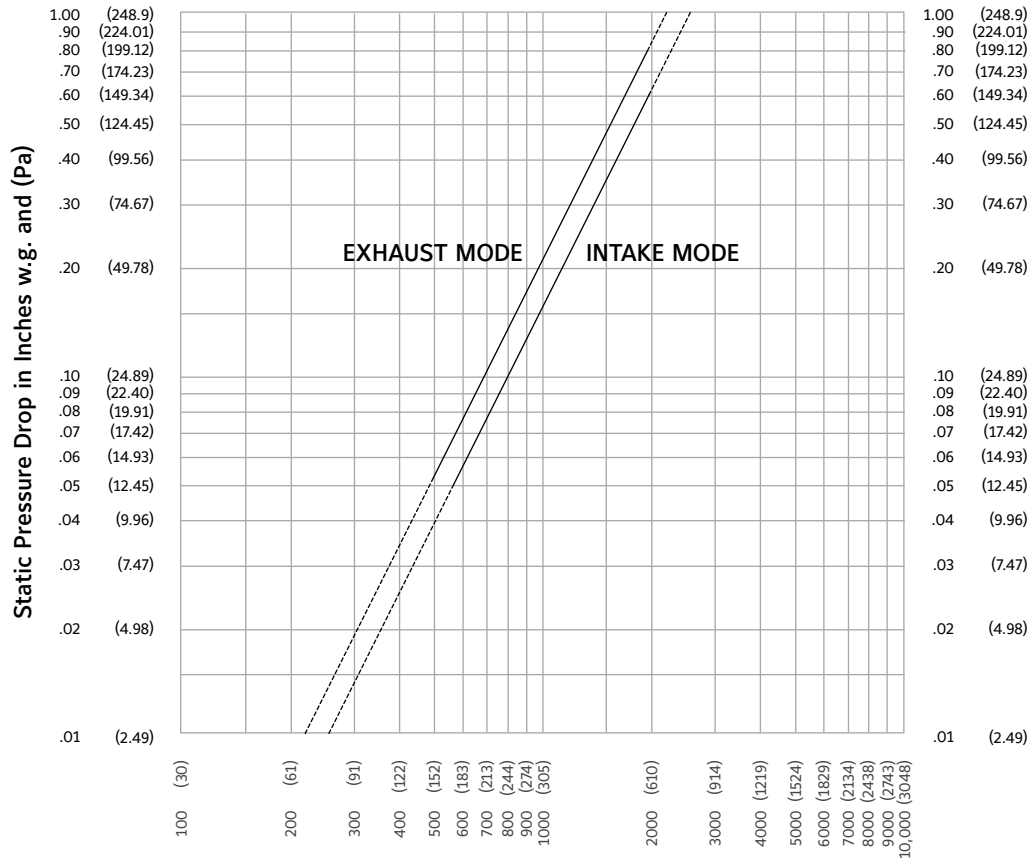

Ratings do not include the effect of a bird or insect screen.

Air Velocity in feet and (meters) per minute through Free Area
(Data corrected to standard air density and AMCA figure or figures testes to 5.5)

WIND-DRIVEN RAIN PERFORMANCE

Test size is 1m x 1m (39" x 39") core area, 1.04m x 1.12m (41" x 44") nominal. Free Area of test louver is 5.45 ft² (.51m²).

29 mph (47 kph) wind & 3" (76) per hour rain conditions

Core Velocity ₁ fpm (m/s)	Airflow cfm (m ³ /min)	Free Area Velocity ₂ fpm (m/sec.)	Effective- ness Ratio	Class ₃	Discharge Loss Class Intake
0 (0)	0 (0)	0 (0)	99.9%	A	2
98 (.5)	1060 (30)	226 (1.1)	99.9%	A	2
197 (1.0)	2119 (60)	389 (2.0)	99.9%	A	2
287 (1.5)	3179 (90)	583 (3.0)	99.9%	A	2
381 (1.9)	4239 (120)	778 (4.0)	99.9%	A	2
476 (2.4)	5299 (150)	972 (4.9)	99.9%	A	2
586 (3.0)	6358 (180)	1167 (5.9)	99.8%	A	2
673 (3.4)	7418 (210)	1361 (6.9)	99.7%	A	2
763 (3.9)	8478 (240)	1556 (7.9)	98.9%	B	2
882 (4.5)	9537 (270)	1750 (8.9)	97.3%	B	2
987 (5.0)	10597 (300)	1944 (9.9)	95.3%	B	2

50 mph (80 kph) wind & 8" (203) per hour rain conditions

Core Velocity ₁ fpm (m/s)	Airflow cfm (m ³ /min)	Free Area Velocity ₂ fpm (m/sec.)	Effective- ness Ratio	Class ₃	Discharge Loss Class Intake
0 (0)	0 (0)	0 (0)	99.4%	A	2
106 (.5)	1060 (30)	226 (1.1)	99.3%	A	2
184 (.9)	2119 (60)	389 (2.0)	99.2%	A	2
282 (1.4)	3179 (90)	583 (3.0)	99.0%	A	2
408 (1.9)	4239 (120)	778 (4.0)	99.0%	A	2
495 (2.5)	5299 (150)	972 (4.9)	98.9%	B	2
567 (2.9)	6358 (180)	1167 (5.9)	98.9%	B	2
680 (3.5)	7418 (210)	1361 (6.9)	98.3%	B	2
791 (4.0)	8478 (240)	1556 (7.9)	97.2%	B	2
882 (4.5)	9537 (270)	1750 (8.9)	95.1%	B	2
982 (5.0)	10597 (300)	1944 (9.9)	23.9%	D	2

NOTE:

1. Core area is the open area of the louver face (face area less louver frames). Core Velocity is the airflow velocity through the Core Area of the louver (1m x 1m).
2. Free Area of test size is calculated per AMCA standard 500-L.
3. Wind Driven Rain Penetration Classes:

Class	Effectiveness
A	1 to .99
B	0.989 to 0.95
C	0.949 to 0.80
D	Below 0.8

4. Intake Discharge Loss Class 2

Discharge Loss Coefficient is calculated by dividing a louver's actual airflow rate vs. a theoretical airflow for the opening. It provides an indication of the louver's airflow characteristics.

Discharge Loss Classes:

Class	Discharge Loss Coefficient
1	0.4 and above
2	0.3 to 0.399
3	0.2 to 0.299
4	0.199 and below

(The higher the coefficient, the less resistance to airflow.)

5. The AMCA Wind Driven Rain Test is performed in a laboratory environment and incorporates controlled wind, water and system airflow effects. In actual field installations, storms may create conditions not considered by the AMCA test. Penthouse and similar applications where wind can pass through multiple louvers in an enclosure is another condition that is not simulated by AMCA tests. These applications can create elevated water penetration rates through any louver. Because of these uncontrolled situations, it is recommended that provisions to manage water penetration through louvers be included in the building design.

AMCA550 DAMPER OPTIONS

CONTROL DAMPER

CD40 (Thin Line Control Damper)

(The CD40 combines the lowest leakage attainable-6cfm/sq.ft. at 4" w.g. with thin line, 4" overall depth when the damper is completely open.)

- ▶ Damper Frame and Blade Depth 4"
- ▶ Max Single Section 60"x 72"
- ▶ Opposed Blade
- ▶ Mill Finish
- ▶ Factory-Installed, pneumatic and electric actuators
- ▶ SP100 Switch Package
- ▶ Jack shafted or Extended Shaft option
- ▶ Concealed Linkage

CD50

(The CD50 is a low Leak, extruded aluminum damper designed with air foil blades for higher velocities and pressure HVAC systems. It meets the leakage requirements of the International Energy Conservation Code by leaking less than 3cfm/sq.ft. at 1" of static pressure and is AMCA licensed as a Class 1A damper)

- ▶ Air Leakage AMCA Class 1A
- ▶ Damper Frame Depth is 5" and Blade width is 6"
- ▶ Max Single Section 60"x 72"

- ▶ Opposed Blade
- ▶ Mill Finish
- ▶ Factory-Installed, pneumatic and electric actuators
- ▶ SP100 Switch Package
- ▶ Jack shafted or Extended Shaft option
- ▶ Concealed Linkage

SMOKE DAMPER

SD60 (UL555S Leakage Class 1 Damper)

(The SD60 is an ultra-low leakage rated smoke damper used in ducts that penetrate smoke rated barriers.)

- ▶ Air Leakage Class 1
- ▶ Damper Frame Depth is 5" and Blade width is 6"
- ▶ Max Single Section 48"x 72"
- ▶ Opposed Blade
- ▶ Mill Finish
- ▶ Factory-Installed, pneumatic and electric actuators
- ▶ SP100 Switch Package
- ▶ Jack shafted or Extended Shaft option
- ▶ Concealed Linkage

TYPICAL INSTALLATION DETAILS

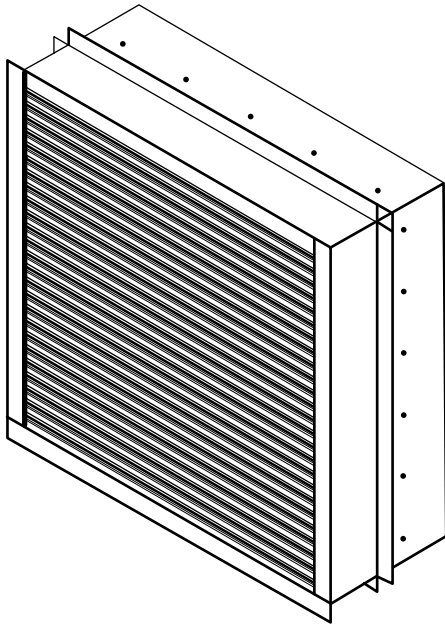

**LOUVER-DAMPER
COMBO**

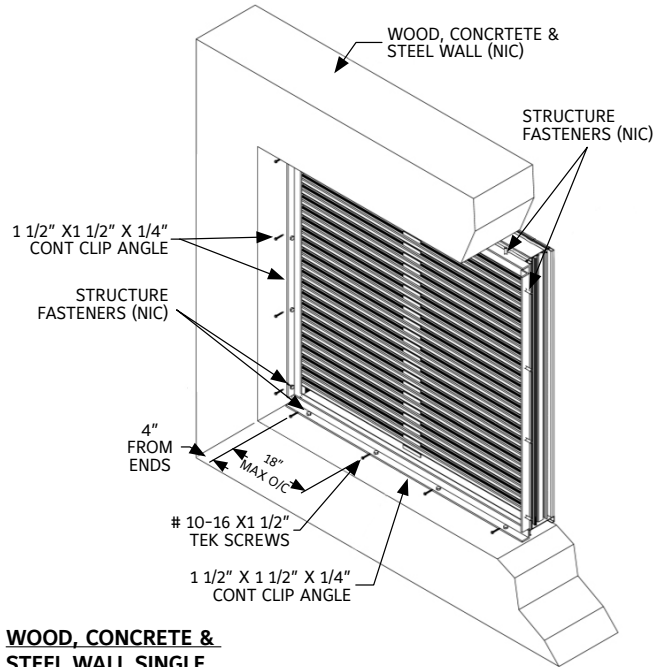

**WOOD, CONCRETE &
STEEL WALL SINGLE
SECTION INSTALLATION**

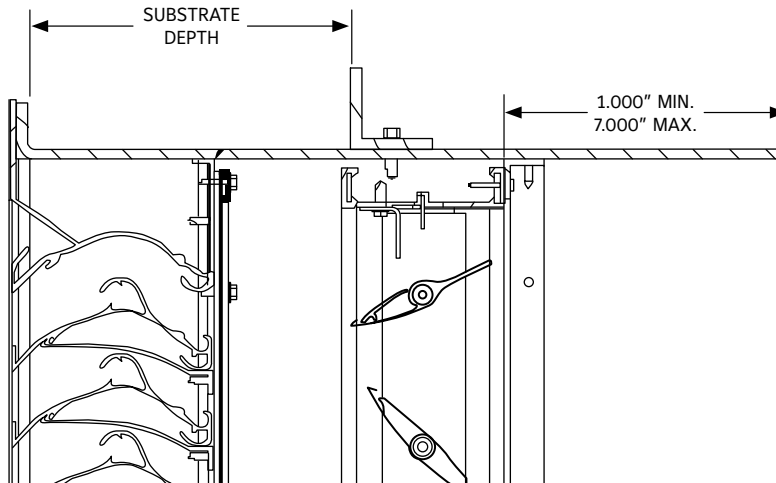

**DETAILS A
HEAD FRAME (FF) - SLEEVE ATTACHMENT DETAIL**

1. Reference separate Installation Instruction sheets for installation details. It is the responsibility of the installing contractor to properly install the louvers per the appropriate detail.
2. Louvers wider than the maximum single section width will be shipped in multiple sections and will require field assembly. Field assembly is not by Ruskin.

SUGGESTED SPECIFICATION

Furnish and install louvers as hereinafter specified where shown on plans or as described in schedules. Louvers shall possess stationary horizontal double drainable blades designed to prevent the penetration of wind-driven rain and meet the performance criteria established by AMCA and tested to TAS 203 (Cyclic Wind Loading), as called out in AMCA540.

Louver blades shall be contained within a 5" (127) frame. Extended sill shall be provided to capture and drain water to exterior of building. Louver components (heads, jambs, sill and blades) shall be factory assembled by the louver manufacturer. Louver sizes too large for shipping shall be built up by the contractor from factory assembled louver sections to provide overall sizes required. Louver design shall limit single span between visible mullions to 10' (3048) wide.

Louvers shall be Ruskin Model EME520DDE construction as follows:

Material

Frame: .081" (2.1) aluminum channel.

Blades: .060" (1.5) nominal wall thickness.

Screen: 5/8" mesh x .040" (16 x 1) expanded flattened aluminum bird screen in removable frame. Drainable blades are positioned at 37 1/2°.

Finish: Select finish specification from Ruskin/Valspar Finishes Brochure.

Published louver performance data bearing the AMCA Certified Ratings Seal for Air Performance and Water Penetration must be submitted for approval prior to fabrication and must demonstrate pressure drop equal to or less than the Ruskin model specified.

FRAME CONSTRUCTION

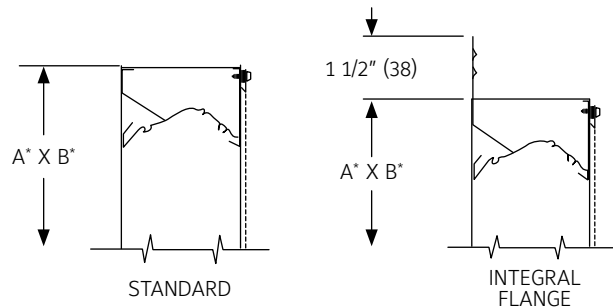

LINKS TO IMPORTANT DOCUMENTS

Document Title
Paint Finishes and Color Guide
Limited Warranty Document



3900 Doctor Greaves Road
Grandview, MO 64030
Website: www.ruskin.com
Phone: (816) 761-7476