



MANUFACTURING CO., INC.

2303 Taylors Valley Road

P.O. Box 210

Belton, Texas 76513-0210

Phone: 254-933-9000

Toll Free: 1-800-251-8265

Fax: 254-939-2644

Sales Fax: 254-933-3159

E-mail: sales@belco-mfg.com

www.belco-mfg.com



**FIBERGLASS DAMPERS
FOR ODOR CONTROL AND CORROSIVE
HVAC SYSTEMS**



©2014 Belco, Inc. All rights reserved. "Belco" and the Belco logo are registered trademarks of Belco Manufacturing Co., Inc., Catalog ID: BELCO Dampers, September, 2014

BELCO FIBERGLASS DAMPERS

BELCO Fiberglass Dampers are manufactured to meet the needs of the odor control and corrosive HVAC industries by providing a corrosion-resistant FRP Damper that is used to regulate a gas flow or shut off and isolate a system. The operating conditions for the dampers are designed to match the operating conditions of the duct system. Premium vinyl ester resins are used throughout the damper. Fire-retardant resins are also available for a Class 1 flame spread.

BELCO MANUFACTURING CO., INC. PROVIDES FOUR DAMPER MODELS:

- Model 201** Used to control airflow for balancing a system. Model 201 is less expensive and has a shaft seal, but does not have a blade seal.
- Model 202** Used to control airflow for balancing a system. Model 202 has a shaft seal and full circumferential blade stop.
- Model 203** Used for isolating a system with low leakage. Model 203 has a shaft seal, blade seal, and a full circumferential blade stop. Designed for up to 30”.
- Model 204** Used for isolating a system, and has a PTFE encapsulated O-ring to provide a factory-tested watertight seal. Each model 204 damper is tested watertight before shipping.

Other Damper Types are Available

Please contact BELCO's sales department at 254-933-9000 or e-mail: sales@belco-mfg.com.

DAMPER NAMES

Dampers are often referred to by many different industry names. The adjacent chart may be used as a guide to determine the BELCO Damper model(s) you require.

INDUSTRY NAME	BELCO MODEL EQUIVALENT
Control Dampers	201, 202
Volume Dampers	201, 202
Butterfly Dampers	201, 202, 203, 204
Shut-off Valves	203, 204
Isolation Valves	203, 204
Watertight Dampers	204 - Watertight

CERTIFIED RATINGS AUTHORIZED BY AMCA

BELCO Manufacturing Company, Inc. certifies that the Standard Model 203 & 204 Dampers shown herein are licensed to bear the AMCA Seal. The ratings shown are based on tests and procedures performed in accordance with AMCA Publication 511 and comply with the requirements of the AMCA Certified Ratings Program. The AMCA Certified Ratings Seal applies to air leakage and air performance ratings only.

- 1.) Test method per AMCA Standard 500-98
- 2.) Air leakage is based on operation between 50°F & 104°F

MODEL 203 ROUND DAMPERS		MODEL 204 ROUND DAMPERS	
DAMPER DIAMETER	6" - 48"	DAMPER DIAMETER	10" - 60"
AMCA LEAKAGE CLASS		AMCA LEAKAGE CLASS	
CLASS 1A 1" wg	CLASS 1 4"wg, 8"wg, 12"wg	CLASS 1A 1" wg	CLASS 1 4"wg, 8"wg, 12"wg

PRESSURE CLASS	LEAKAGE, L/s/m ² (ft ³ /min/ft ²)			
	REQUIRED RATING		EXTENDED RANGE (OPTIONAL)	
	0.25 kPa (1" wg)	1.0 kPa (4" wg)	2.0 kPa (8" wg)	3.0 kPa (12" wg)
1A	15.2 (3)	N/A	N/A	N/A
1	20.3 (4)	40.6 (8)	55.9 (11)	71.1 (14)
2	50.8 (10)	102 (20)	142 (28)	178 (35)
3	203 (40)	406 (80)	569 (112)	711 (140)

Contact BELCO Manufacturing Company, Inc. for tested leakage rates.

AIR PERFORMANCE FOR BELCO MODEL 203 & 204 DAMPERS FULL OPEN POSITION

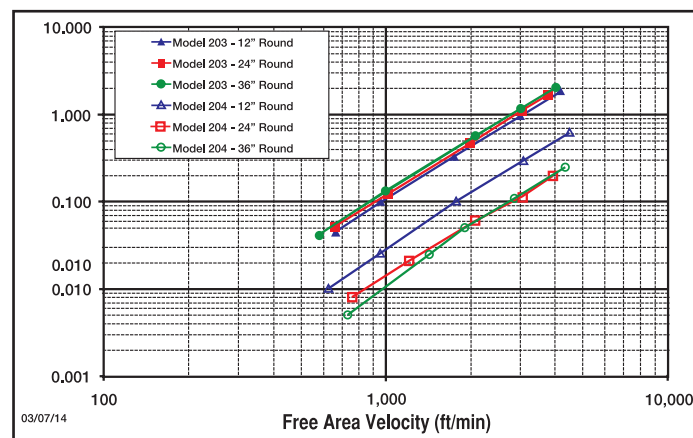

Tested to AMCA 5.3



WARRANTY

BELCO Fiberglass Dampers are warranted for eighteen (18) months from the date of shipment to be free from defects in manufacturing, materials, or workmanship. Liability shall not exceed the purchase price of the damper and, at BELCO's option, is limited to repair or replacement. BELCO Manufacturing Co., Inc. shall not be liable for any costs incurred either directly or indirectly other than repair or replacement of the product.

MODEL 201 DAMPER

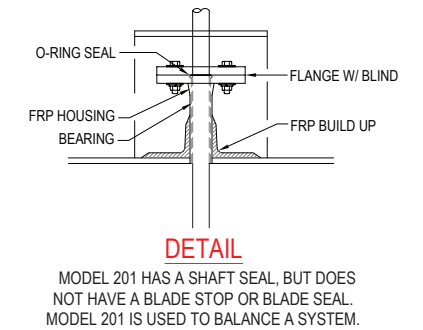
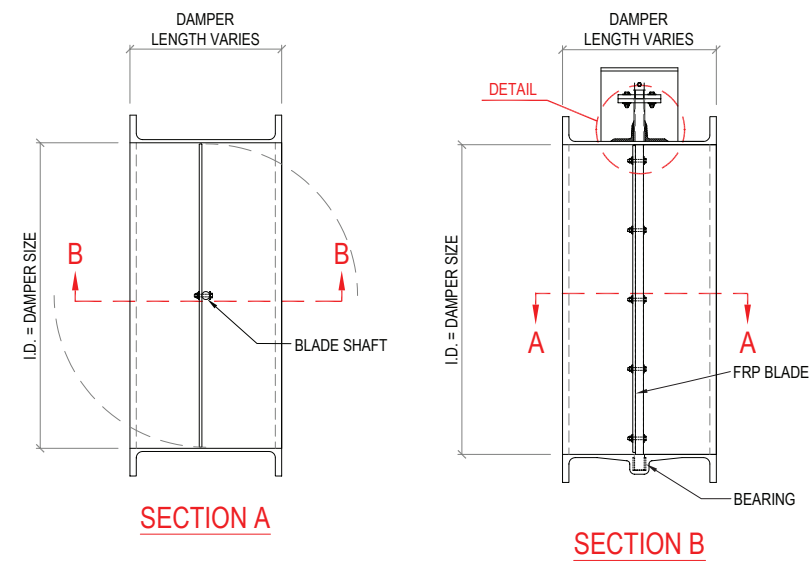

MODEL 202 DAMPER

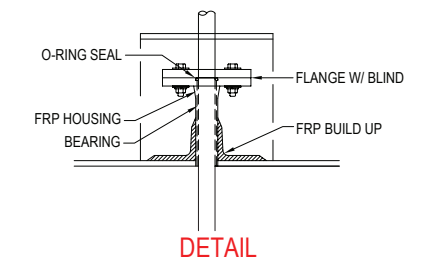
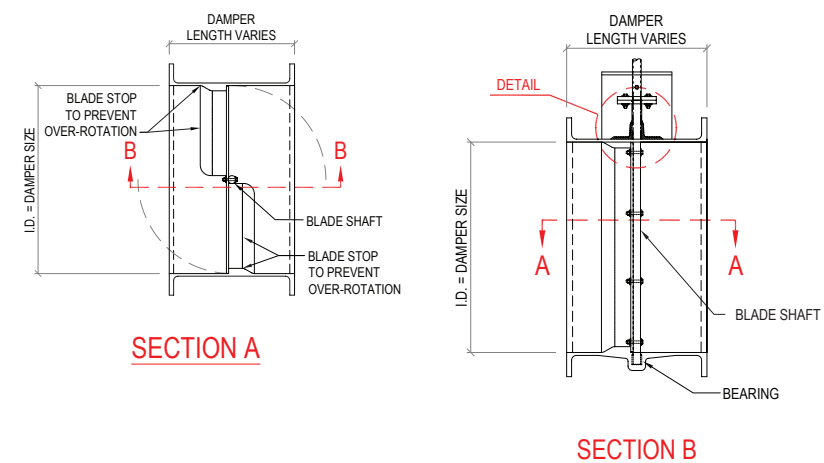

MODEL 203 DAMPER

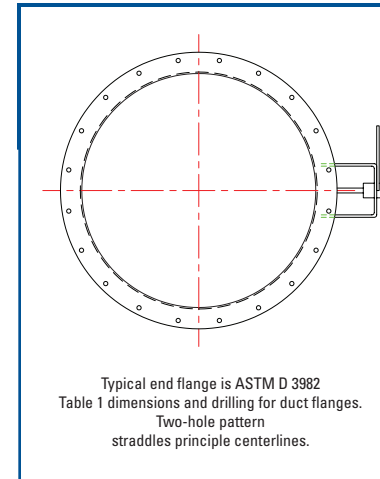
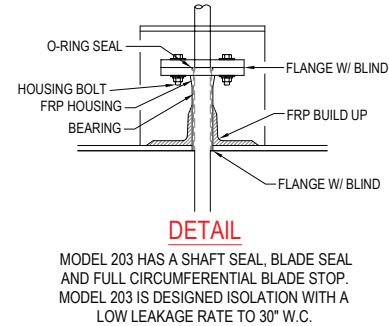
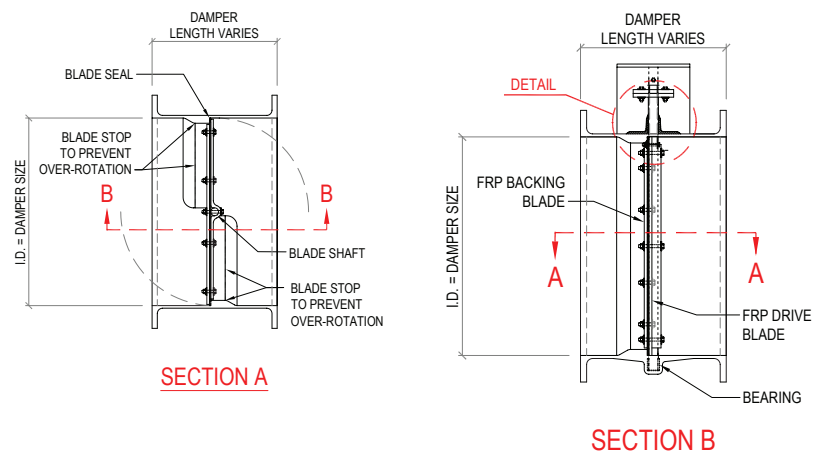

BELCO DAMPERS

SUGGESTED SPECIFICATION FOR MODEL 203 FRP DAMPERS*

Furnish and install at locations shown on plans, round FRP single-blade fiberglass dampers. Damper frame shall be of one piece construction with a resin rich interior corrosion barrier minimum of 100 mils. A structural lay-up shall consist of alternate layers of chopped strand mat and woven roving to conform to ASME/ANSI RTP-1 and ASTM D3982. The glass to resin ratio shall be a minimum of 35% glass to 65% resin. Wall thickness, flange thickness, drilling pattern and width shall conform to ASTM D3982 Table 1. Exterior surface of the damper shall contain UV inhibitors and a gel-coat, color to match duct system.

STANDARD CONSTRUCTION, TYPICAL OF MODEL 203

Resin System: Fire Retardant (FR) Vinyl Ester with MEKP Cure System

Frame: FR Vinyl Ester FRP

Axle: 316 or 304 Stainless Steel

Sizes: See Table Below

Max Operating Temp.: 200°F

External Coating: Gel Coat with UV (White, Gray, or Tan)

Face to Face: See Table Below

Actuator: Locking quadrant hand lever through 20" diameter, worm gear for larger than 20". (Electronic, pneumatic, and chain-wheel operators are available).

Options: Dampers can be made with a variety of resins, cure systems, gasket materials, shaft materials, internal hardware, external hardware, coatings, flange patterns, actuators, and face to face lengths. Contact BELCO Manufacturing for other available options.

Blade: FR Vinyl Ester FRP

Bearings: Teflon

Internal Hardware: 304 or 316 SS

Max System Pressure: 30" wg

Connections: ASTM D 3982 Table 1 for Standard Ductwork

Gasket: EPDM

The damper blade shall be constructed of the same material as the damper frame and shall have a resin rich surfacing veil on both sides. Blade stiffeners shall be FRP or FRP encapsulated as required for stiffness.

The axle shall be 304 or 316 stainless steel or pultruded FRP as required to meet corrosion resistance requirements. Leakage shall not exceed 3 cfm per square foot at 12" wc or 5.25 cfm per square foot at 30" wc as required in this specification for isolation. Damper shall be provided with stainless steel hand locking quadrant, gear operators, chain wheel operators, or other actuation devices as required in this specification. All interior metal shall be 304 or 316 stainless steel. Gaskets shall be EPDM. Other gasket materials shall be available upon request.

All FRP fabrication shall meet or exceed quality requirements of ASTM D 3982 and ASME/ANSI RTP-1. Damper shall be Belco Manufacturing Models 201, 202, 203.

CUSTOM CONFIGURATIONS:

BELCO dampers can be furnished in a variety of custom configurations including: extended length between flanges, undrilled flanges, inline dampers, either built into a section of duct or plain-end for field joint by installers.

MODEL 204 DAMPER

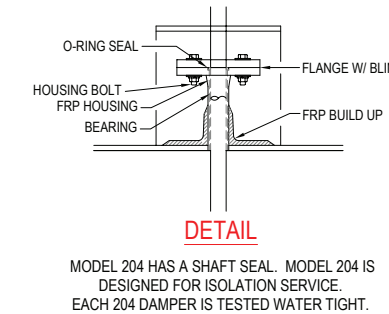
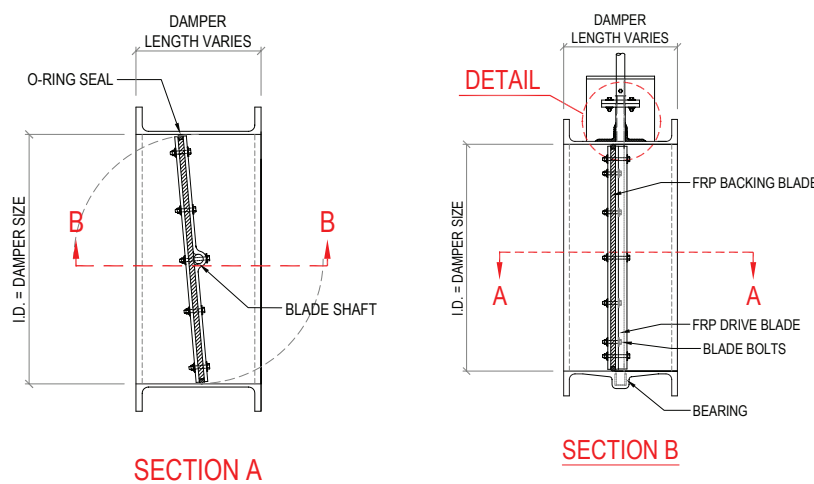

FLANGE SIZES	FLANGE THICKNESS	FLANGE O.D.	BOLT CIRCLE DIA.	BOLT HOLE DIA.	# OF BOLT HOLES	BLADE EDGE THICKNESS	AXLE DIA.	FACE TO FACE LENGTH	APPROX. TORQUE REQUIREMENTS (in-lb)
4"	1/2"	8 3/8"	7"	7/16"	4	5/16"	3/4"	12"	200
6"	1/2"	10 3/8"	9"	7/16"	8	5/16"	3/4"	12"	200
8"	1/2"	12 3/8"	11"	7/16"	8	5/16"	3/4"	12"	300
10"	1/2"	14 3/8"	13"	7/16"	12	5/16"	3/4"	12"	660
12"	1/2"	16 3/8"	15"	7/16"	12	3/8"	3/4"	12"	660
14"	1/2"	18 3/8"	17"	7/16"	12	3/8"	3/4"	12"	660
16"	1/2"	20 3/8"	19"	7/16"	16	3/8"	3/4"	12"	800
18"	1/2"	22 3/8"	21"	7/16"	16	3/8"	3/4"	12"	1000
20"	1/2"	24 3/8"	23"	7/16"	20	3/8"	3/4"	12"	1100
24"	1/2"	28 3/8"	27"	7/16"	20	1/2"	1 1/4"	12"	1350
30"	5/8"	34 3/8"	33"	7/16"	28	1/2"	1 1/4"	15"	1750
36"	5/8"	40 3/8"	39"	7/16"	32	1/2"	1 1/4"	15"	2200
42"	5/8"	46 3/8"	45"	7/16"	36	5/8"	2"	15"	2500
48"	5/8"	54 3/8"	52"	9/16"	44	5/8"	2"	15"	2900
54"	5/8"	60 3/8"	58"	9/16"	44	5/8"	2"	18"	3300
60"	5/8"	66 3/8"	64"	9/16"	64	3/4"	2"	18"	3700
72"	3/4"	78 3/8"	76"	9/16"	76	3/4"	2 1/2"	24"	4500

*Larger sizes are available. Contact a BELCO representative for more information. Contact BELCO for specifications on other damper models.