

Application

CD-41 and CD-42 control dampers employ triple-V blades and a rugged hat channel frame for automatic air control and manual balancing in medium pressure and velocity applications.

Standard Construction

Frame: 5" × 1" (127 × 25) galvanized steel hat channel with interlocking corner gusset. Equivalent to 13 gauge (2.4) channel frame. Low profile head and sill are used on sizes less than 13" (330) high.

Blades: 6" × 16 gauge (152 × 1.5) galvanized steel — triple-V. Parallel (model CD-41) or opposed (model CD-42) action.

Axles: 1/2" (13) diameter plated steel hex.

Linkage: Concealed in frame.

Bearings: Synthetic

Control Shaft: 1/2" × 6" (13 × 152) round drive axle with outboard shaft support bracket and bearing supplied on all single section dampers for field installation. Factory installed jackshaft supplied with all multiple section dampers: 1/2" (13) dia. for W>48" (1219) or H>72" (1829), 3/4" (19) dia. for W >96" (2438).

Minimum Size: Model CD-41 (one blade): 5" × 5" (127 × 127)
Model CD-41 and CD-42 (two blades): 5" × 10" (127 × 254)

Maximum Size: Single section: 48" × 72" (1219 × 1829)
Multiple sections: Unlimited

Options

- Factory installed actuators:
 - Manual locking quadrant (supplied loose)
 - 24 VAC 120 VAC 230 VAC
 - Pneumatic Modulating
 - External mount (requires sleeve or sideplate option)
 - Internal mount (requires jackshifting)
- Factory installed sleeve. Factory installed side plate.
 - Gauge: 20 (1.0) 16 (1.6)
 - Length: 16" (406) 24" (610) Other _____
- Transitions (sleeve required): Flanged
 - Round: AR CR Oval: AO CO
 - 1" (25) S-clip 1 1/2" (38) S-clip DM-25 DM-35
- Flanged frame: One side Both sides
- Low leakage seals: PVC blade edge and flexible metal jamb.
- PI-50 – Dual position indicator switch package.
- Actuator/Quadrant standoff bracket — accommodates up to 3" (76) thick insulated duct.
- Stainless steel oilite sleeve-type bearings.
- Type-304 stainless steel construction.
- Jackshifting (required with internal mounted actuators and standard on all multiple section dampers).
- Vertical mounted blades with thrust washers.
- Face and by-pass assemblies:
 - Model MDFBR Model MDFBH Model MDFBV

Ratings

Damper Width	Maximum System Pressure	Maximum System Velocity
12" (305)	5.0 in. wg (1.2 kPa)	3000 fpm (15.2 m/s)
24" (610)	4.0 in. wg (1.0 kPa)	3000 fpm (15.2 m/s)
36" (914)	3.0 in. wg (0.8 kPa)	2500 fpm (12.7 m/s)
48" (1219)	2.5 in. wg (0.6 kPa)	2000 fpm (10.2 m/s)

Leakage (with seals): 8.0 cfm/ft² @ 4 in. wg (0.04m³/s/ m² @ 1.00 kPa)
4.0 cfm/ft² @ 1 in. wg (0.02m³/s/ m² @ 0.25 kPa)

Temperature: -25°F to 350°F (-32°C to +177°C)

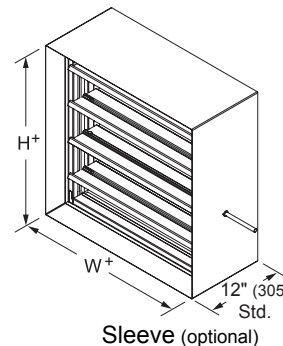
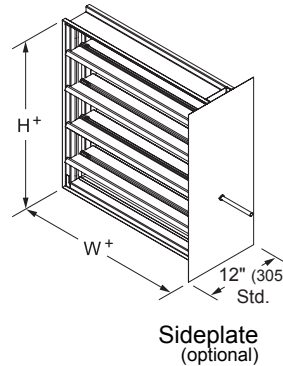

*Damper dimensions furnished approximately 1/4" (6) undersize (sleeve thickness not included).

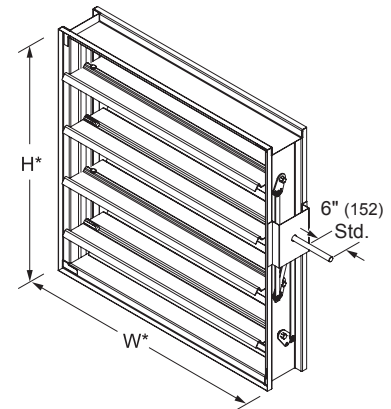

Model CD-42 (standard)
*Damper dimensions furnished approximately 1/4" (6) undersize. (Drive axle supplied loose for field installation)



CD-41



CD-42

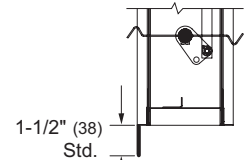

Flanged Frame



Air Performance

Pottorff certifies that the model CD-41 and CD-42 shown herein is licensed to bear the AMCA seal. The ratings shown are based on tests and procedures performed in accordance with AMCA publication 511 and comply with the requirements of the AMCA Certified Ratings Program. The AMCA Certified Ratings Seal applies to air performance ratings only.

Typical Damper Dimensional Details

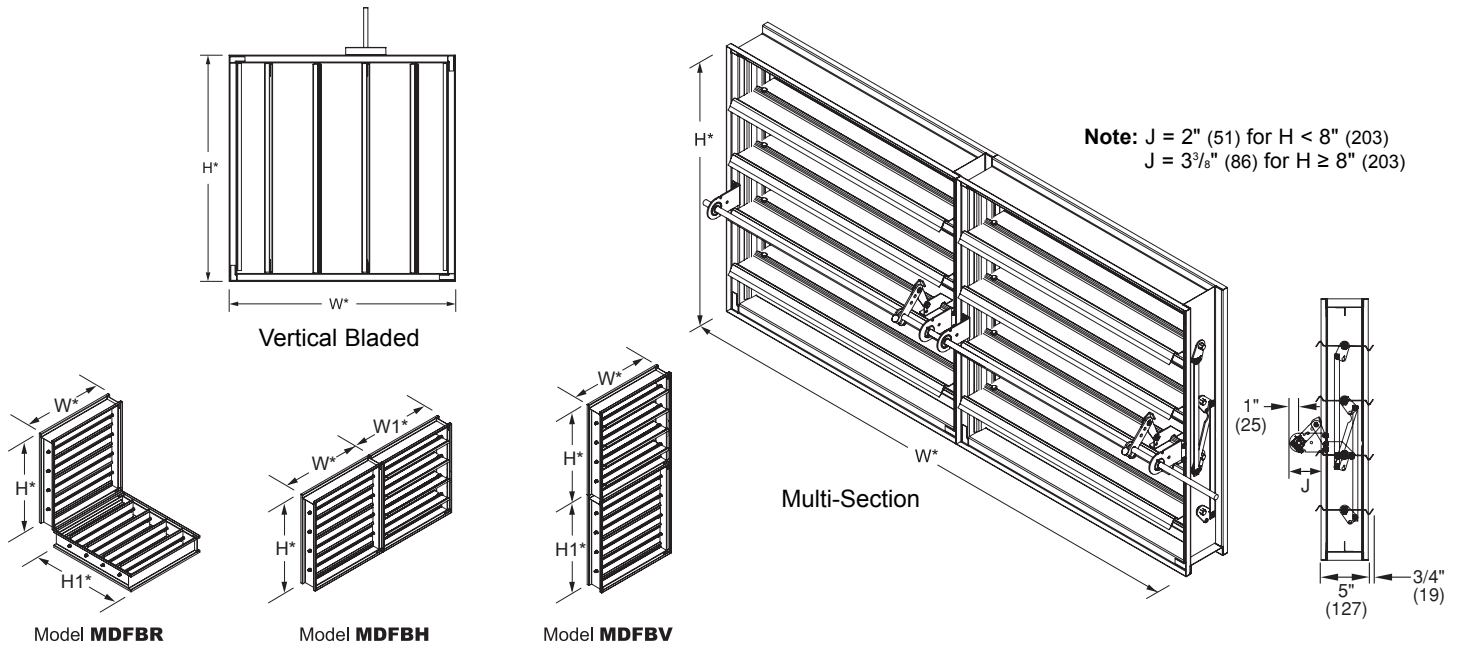

Dampers are designed to be self-supporting in the maximum single section size. When dampers are installed in multiple section assemblies, bracing may be required to support the weight of the dampers and to ensure structural integrity against system pressures. It is recommended that multiple sections be appropriately braced. In horizontal installations, it is recommended that suitable supports be installed every 8 feet of damper width. Dampers installed in vertical multiple assemblies and/or higher system pressures, may require additional bracing.

*Damper dimensions furnished approximately 1/4" (6) undersize.

Airflow Performance Data

Pressure Loss vs. Velocity

Figure 5.3 — Ducted Inlet and Outlet

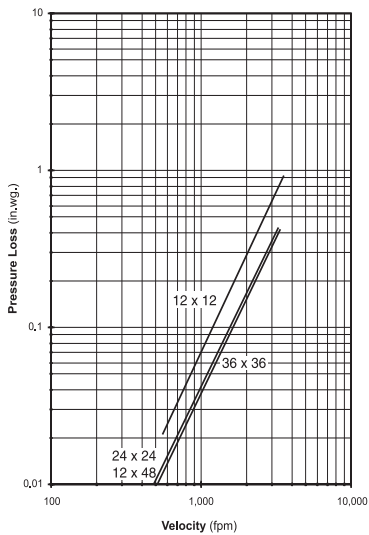

Figure 5.2 — Ducted Inlet

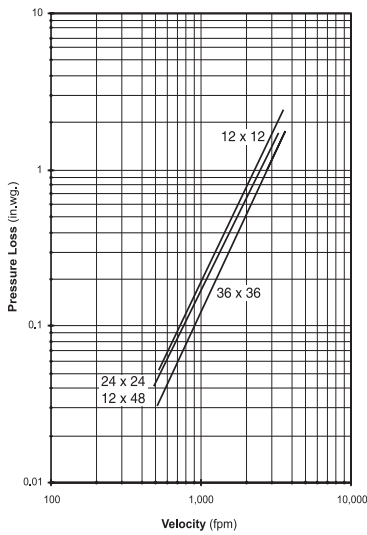
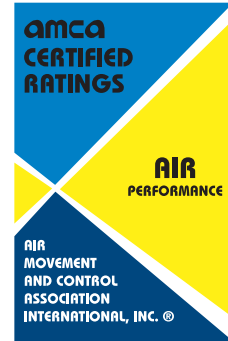
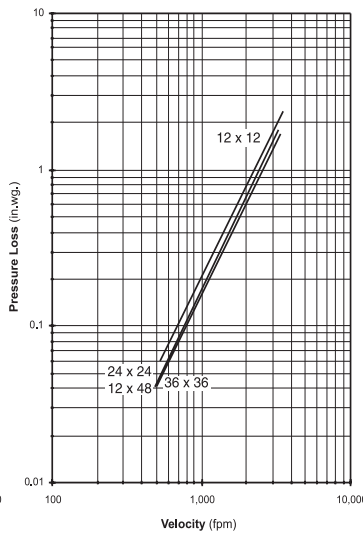

Figure 5.5 Plenum Mount



Air Performance

Pottorff certifies that the model CD-41 and CD-42 shown herein is licensed to bear the AMCA seal. The ratings shown are based on tests and procedures performed in accordance with AMCA publication 511 and comply with the requirements of the AMCA Certified Ratings Program. The AMCA Certified Ratings Seal applies to air performance ratings only.

Pressure drop testing was performed in accordance with AMCA Standard 500-D using the three configurations shown. All data has been corrected to represent air density of 0.075 lb/ft. Actual pressure drop in any ducted HVAC system is a combination of many elements. This information, along with analysis of other system influences, should be used to estimate actual pressure losses for a damper installed in a given HVAC system.

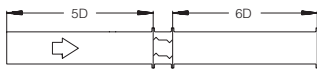

Ducted Inlet and Outlet

AMCA Figure 5.3 illustrates a fully ducted damper. This configuration represents the lowest pressure drop of the three test configurations because entrance and exit losses are minimized by straight duct runs upstream and downstream of the damper.

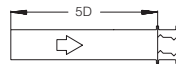

Ducted Inlet

AMCA Figure 5.2 illustrates a ducted damper exhausting air into an open area. This configuration has a lower pressure drop than Figure 5.5 because entrance losses are minimized by a straight duct run upstream of the damper.



Plenum Mount

AMCA Figure 5.5 illustrates a plenum mounted damper. This configuration has the highest pressure drop because of extremely high entrance and exit losses due to the sudden changes of area in the system.

Information is subject to change without notice or obligation.

NOTE: Dimensions in parentheses () are millimeters.