



INDUSTRIAL PROCESS AND
COMMERCIAL VENTILATION SYSTEMS

DOWNBLAST ROOF EXHAUSTERS

DCRD | BCRD



DOWNBLAST ROOF EXHAUSTERS



Overview

DCRD | BCRD

Twin City Fan & Blower's line of quiet, efficient and economical centrifugal roof exhausters are designed for roof mounted exhaust of relatively clean air. They offer world-class performance and quality in a wide variety of commercial and industrial ventilating applications. Models DCRD (direct drive) and BCRD (belt driven) feature spun aluminum construction.

Typical Applications Include

Agriculture, Air Pollution Control, Automotive, Boilers, Brick, Car Wash, Commercial Plan & Spec, Composting, Ethanol, Food & Beverage, Foundry, General Manufacturing, Glass, HVAC, Institutional & Hospitality, Metal & Minerals, Microchip, OEM, Pharmaceutical, Power Generation, Recycling, Textile, Transportation, Warehouse Exhaust

Impeller Types

Backward Inclined Centrifugal

Optional Construction

Special Coatings, Spark Resistant, UL 705

Certifications

AMCA Sound/Air and FEI, UL 705 Listed for Electrical, Miami-Dade County Hurricane Rating per NOA No. 26-0312.02.

Now Available with



see page 7



DCRD and BCRD models are cULus 705 listed for electrical, File No. E158680.



Twin City Fan & Blower certifies that the Models DCRD and BCRD shown herein are licensed to bear the AMCA Seal. Certified performance data may be found in Twin City Fan & Blower's Fan Selector software.



Scan the QR code to search Twin City Fan & Blower's AMCA-certified products.

Energy Regulations

Twin City Fan & Blower supports energy efficiency regulations enacted by the U.S. Department of Energy (DOE) and specific states. The selection and application of fan products is a significant part of these regulations. Engineers and specifiers must understand how to apply TCF products to their specific applications to meet applicable DOE and state regulatory requirements. Twin City Fan & Blower has made significant investments in product testing and development to provide efficient products. Developments in Twin City Fan & Blower's Fan Selector software are in place to aid your decision in product selection to assist with meeting the efficiency requirements as stipulated in the applicable regulations.



For complete product performance, drawings and available accessories, download our Fan Selector software at tcf.com.

DOWNBLAST ROOF EXHAUSTERS

Overview

DCRD | BCRD

The centrifugal roof exhausters are designed for roof mounted exhaust of relatively clean air. Typical applications include general HVAC, warehouse exhaust, and exhaust for churches, schools and offices.

Model DCRD (Direct Drive)

12.7" to 19.8" (325 mm to 505 mm) impeller diameters
Airflow to 5,600 CFM (9,500 m³/hour)
Static pressure to 1" w.g. (250 Pa)

Model BCRD (Belt Driven)

8.5" to 50.5" (220 mm to 1,285 mm) impeller diameters
Airflow to 28,700 CFM (48,800 m³/hour)
Static pressure to 3.25" w.g. (810 Pa)

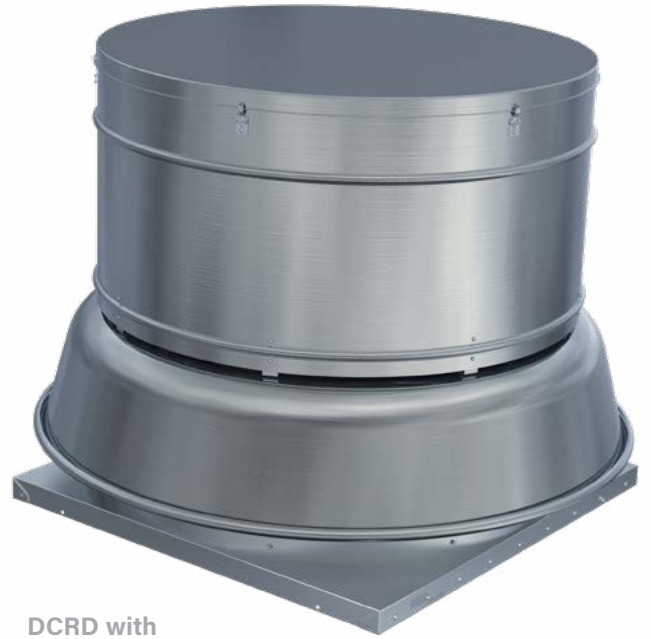

DCRD with
Spun Aluminum Housing



General HVAC
School Exhaust



Housings - BCRD and DCRD housings feature heavy-gauge spun aluminum construction of the shroud and top cover. Shrouds feature a rolled bead edge for rigidity. Motor bands are constructed of heavy-gauge aluminum, rolled and beaded for rigidity. All housings provide complete protection of the motor and drive assembly, while allowing quick access to these components.

Bearings - Heavy-duty re-greaseable pillow block ball bearings are specifically designed for air handling applications to provide an average life (L-50) of 500,000 hours or more at maximum cataloged operating speeds.

Shaft - Precision ground and polished with a first critical speed of at least 125% of the fan's maximum operating speed.

Drive - Adjustable pitch V-belt drives with cast iron sheaves and heat resistant belts are selected at 150% of the driven motor horsepower.

Motors - ODP, TEFC and explosion proof, single and three phase motors are carefully matched to the fan load.

Vibration Isolation - Motor and drive assembly is completely isolated from the fan supports by rubber isolators to reduce transmission of noise and vibration.

Impeller - Quiet and efficient non-overloading impellers with backwardly curved blades are precisely matched to a deep spun venturi. All impellers are statically and dynamically balanced to ensure smooth and quiet operation.

Galvanized Bird Screen - Protects the impeller, inlet and internal components from entry of birds.

Curb Cap - One-piece curb cap/inlet venturi assembly provides protection from weather. Prepunched mounting holes provide easy and accurate attachment to the roof curb.

Conduit Tubing - A conduit tube is furnished for running electrical wiring through the curb cap and into the motor compartment.

Disconnect Switch - Standard on all units. Fans are provided with a NEMA 1 type disconnect switch mounted in the motor compartment when ODP or TEFC motors are used. When explosion proof motors are specified, a NEMA 7/9 disconnect switch will be shipped loose for field mounting and wiring.

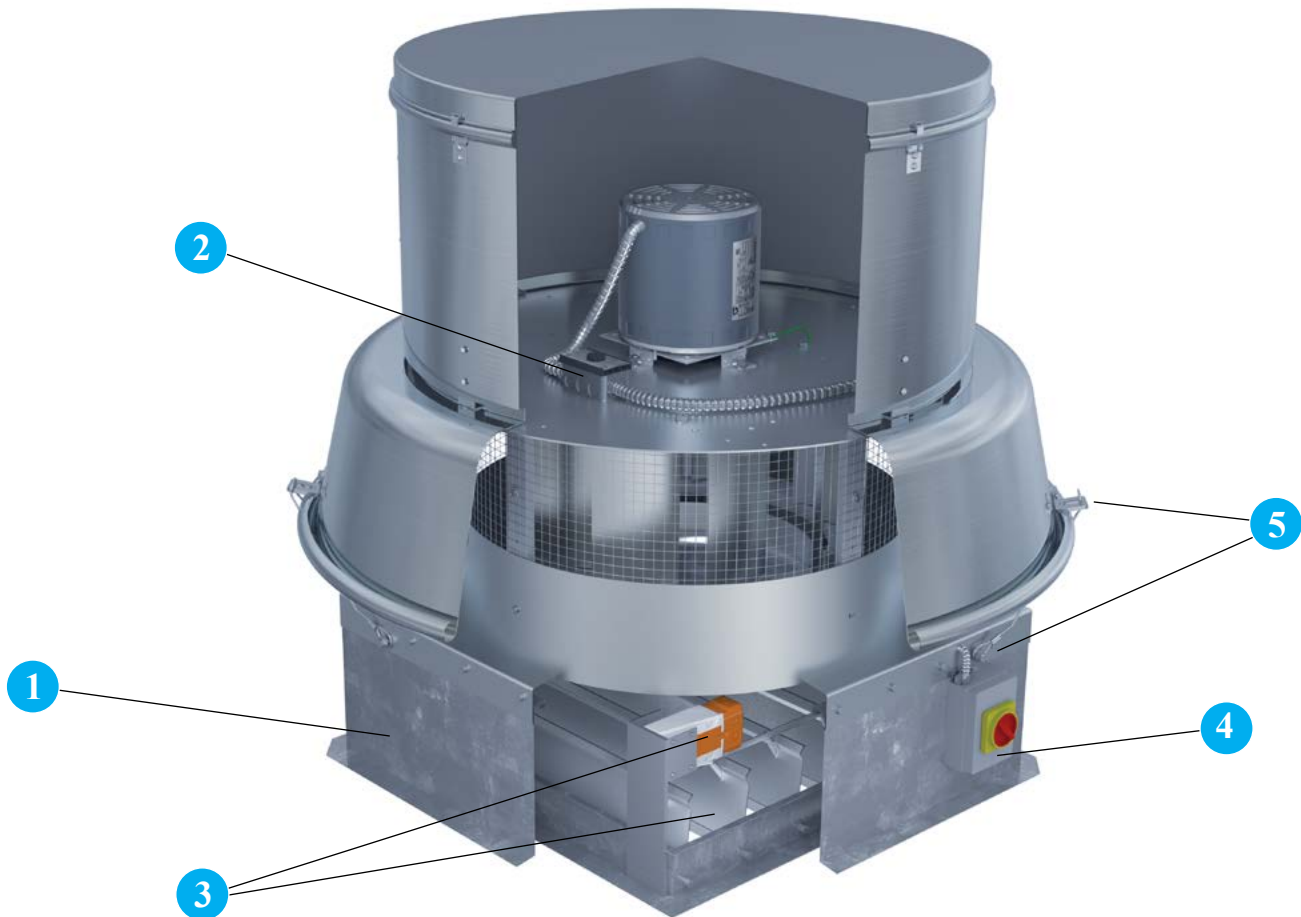

1 Self-Flashing Roof Curb Prefabricated roof curbs are available in heavy-duty galvanized steel or aluminum construction, in heights of 8", 12" or 18". The self-flashing curb is provided with a factory installed $\frac{3}{16}$ " polystyrene gasket. Curbs are provided with 1.5" of insulation as standard and feature continuously-welded seams for added rigidity and moisture protection. Prefabricated curbs are also available in raised cant, pitched and peak models. Refer to Catalog 4910 for complete details on roof curb options. Minimum 12" high curbs are recommended for use with motorized dampers.

2 Variable Speed Control is an optional accessory on all DCRD models with 115 volt, open type motors, to allow the adjustment of airflow for system balancing. Variable speed controllers are solid-state (Tri-ac) design and are designed to start the motor on high speed for better startup characteristics. Variable speed controls can be shipped separately, factory installed or field installed on the unit at a later date. Motor must be ODP 115V, PSC or shaded pole type.

3 Backdraft Damper, with automatic or motorized operation, feature a felt seal on the edge of the damper blades for quiet operation. Damper frames are constructed of galvanized steel and blades are constructed of aluminum.

Motorized dampers are recommended for low CFM applications to assure unrestricted airflow. Motorized dampers are available with 115, 208, 230, 460, 575 or 24 volt service. End switches are available. When a motorized damper option is selected a 12" (or greater) high roof curb is required.

4 NEMA 4 Disconnect Switch provides positive electrical shutoff when fan cleaning or maintenance of fan and is water and dust tight. Switch is available shipped loose for field mounting and wiring or factory mounted and wired. NEMA 3R enclosure is also available.

5 Tie-Down Brackets A quantity of four brackets are mounted to the fan shroud to allow the fan to be secured to the roof in areas where high winds are a concern. Guy wires are supplied and installed by others.

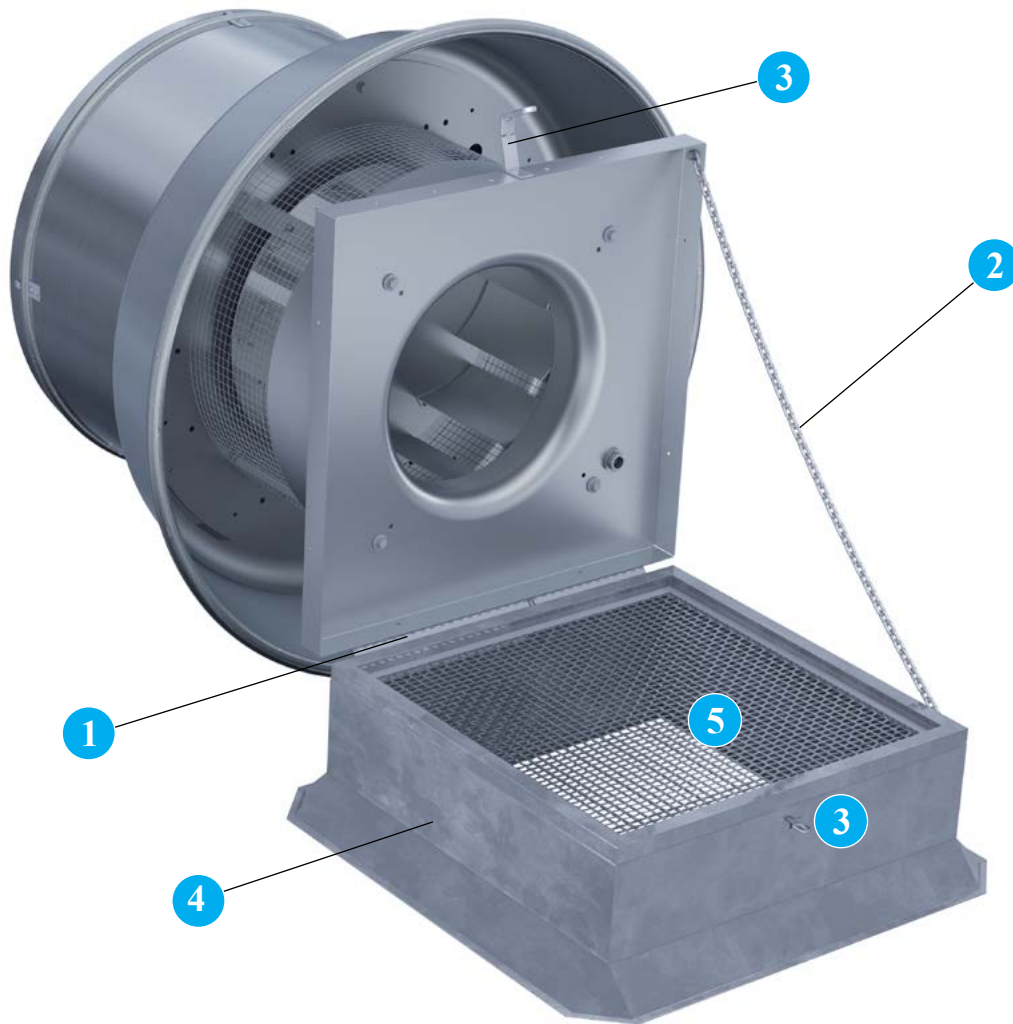

1 Curb Hinge The curb hinge arrangement provides easy access to the exhaust fan, backdraft damper and duct for servicing and cleaning. The curb hinge is of the piano type, running the entire length of the fan's curb cap. The curb hinge option ships loose and is designed for use with a standard canted curb only (1.5" less than fan base). This option cannot be used with self-flashing curbs.

2 Retaining Chain is available in conjunction with the curb hinge arrangement to stabilize the unit and to prevent damage from occurring to the unit while servicing and cleaning.

3 Security Hasp A security hasp is available in conjunction with the curb hinge arrangement to prevent removal of the unit from the unit curb cap and prevent entrance into the building through the roof's ductwork.

4 Canted Roof Curb Prefabricated roof curbs are available in heavy-duty galvanized steel or aluminum construction, in heights of 8", 12" or 18". The canted curb is provided with a factory installed wood nailer. Curbs are provided with 1.5" of insulation as standard and feature continuously-welded seams for added rigidity and moisture protection. Prefabricated curbs are also available in raised cant, pitched and peak models. Refer to Catalog 4910 for complete details on roof curb options. Minimum 12" high curbs are recommended for use with motorized dampers.

5 Insect Screen Provides protection from entry of insects into impeller, inlet and interior of building.

1 Auto Belt Tensioner Spring loaded pulley used for automatic belt tensioning. Eliminates the need for regular belt tensioning and extends belt life.

2 Miami-Dade Construction All sizes on model DCRD and sizes 070-360 on model BCRD are available with optional Miami-Dade Hurricane Construction. With this option, units are rated for wind loads up to 150 miles per hour, with a self-flashing roof curb. In conjunction with independent, licensed Florida Professional Engineers, these fans have undergone rigorous design, analysis and testing to ensure they meet the stringent product requirements of Miami-Dade County. Twin City Fan & Blower's NOA (Notice of Acceptance) number is 26-0312.02 and can be found on the Miami-Dade County website.



OTHER OPTIONS/ACCESSORIES INCLUDE:

Special Coatings Coatings will be available for protective and decorative purposes. Contact your Twin City Fan & Blower sales representative for more information about available coatings and colors.

Straight-Sided Roof Curb Prefabricated roof curbs are available in heavy-duty galvanized steel or aluminum construction, in heights of 8", 12" or 18". The straight-sided style curb is provided with a factory installed damper tray and wood nailer, manufactured with the outside dimensions of a canted curb (1.5" less than fan curb cap inside dimension). Curbs are provided with 1.5" of insulation as standard and feature continuously-welded seams for added rigidity and moisture protection. Prefabricated curbs are also available in canted, self-flashing, pitched and peak models. Refer to Catalog 4910 for complete details on roof curb options. Minimum 12" high curbs are recommended for use with motorized dampers.

Two-Speed Switch Two-speed switch is available for two speed/two winding motors to control the fan speed (high speed, low speed, off). Available on single phase, 1 HP and below.

Firestat Designed to shut down fan in the event of a fire to prevent spreading. For use with single phase motors only. Available shipped loose for field mounting and wiring or factory mounted and wired.

AMCA Spark B Includes a non-ferrous (aluminum) impeller and an aluminum rubbing plate around the opening through which the shaft passes.

Performance Baffle Inlet plate with customized diameter to meet specific performance point. Ships loose for field mounting.

ELECTRONICALLY COMMUTATED MOTORS

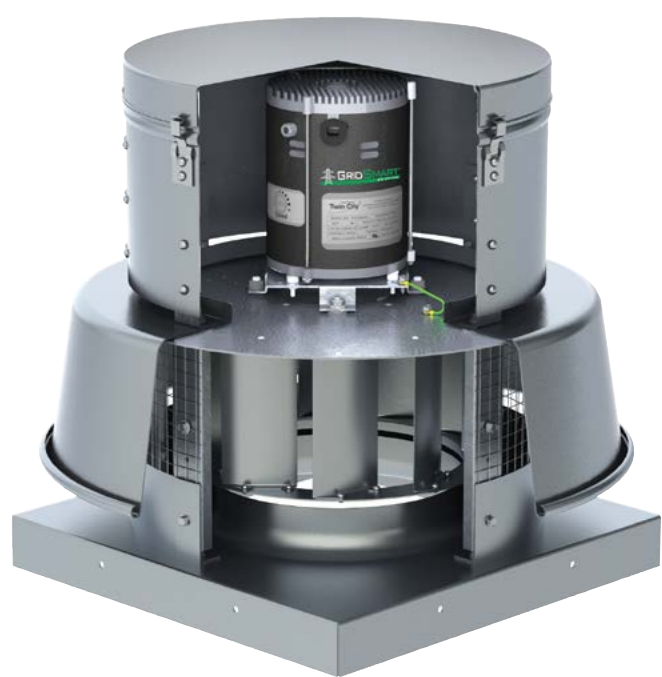

Model DCRD
With GridSmart™ EC Motor

Twin City Fan & Blower offers its own line of custom engineered Electronically Commutated (EC) motors. Electronic commutation is the latest motor technology to be used in direct drive fans. Also known in the industry as Brush Free or Brushless DC, the EC motors utilize an electronic circuit board to control the functionality of the motor. The motor operates off of single phase AC power, which is converted to DC power within the motor's circuitry. Twin City Fan & Blower has motor options available for 115V or 208-230V single phase electrical power. The result is a highly efficient motor, even at part load, with an expanded speed control range and a variety of speed control options from which to choose. EC motors are available in ODP, TENV and TEFC enclosures.



Benefits

- Efficiencies up to 85%
- Constant efficiency as the motor speed is varied
- Up to 66% energy savings over traditional PSC motors
- Performance range comparable to a belt driven fan with reduced maintenance benefits of a direct drive fan
- 80% usable turndown range as compared with 40% maximum on PSC motors
- Soft start gives fans smooth, quiet start
- Lower operating temperatures result in longer life and reduces energy consumption
- Heavy-duty ball bearings are permanently lubricated
- Elimination of VFD results in lower initial cost

EC Motor Options

1/6 HP to 1 HP

- 1/6 HP: 115V, single phase
- 1/4 HP – 1HP: 115V, 208-230V single phase
- ODP or TENV Enclosure
- Motor mounted speed control dial as standard
- 0-10VDC control leads as standard
- Available with remote mounted speed control dial

1 HP & 2 HP

- 1 HP: 115V, 208-230V, single phase
- 2 HP: 208-230V, single phase
- TEFC enclosure (totally enclosed fan cooled)
- Available with motor mounted speed dial or 0-10VDC control lead



1 HP & 2 HP
GridSmart™ EC Motors



1/6 HP to 1 HP
GridSmart™ EC Motors

Overview

Canted Roof Curbs

- Constructed of 18-gauge galvanized steel with continuously-welded seams
- Large 3" built-in 45° cant to accommodate roofing material to top of curb. Cant is beveled at corners for better support of roofing material
- Wood nailer (1 1/2") secured to top ledge
- Lined with 1 1/2" fiberglass fire-resistant, sound-absorbing insulation
- Damper shelf standard
- Options: Aluminum (16-gauge) construction, burglar security bars, metal liner (galvanized or aluminum), special heights up to 24", single- or double-pitched curbs for sloping roofs

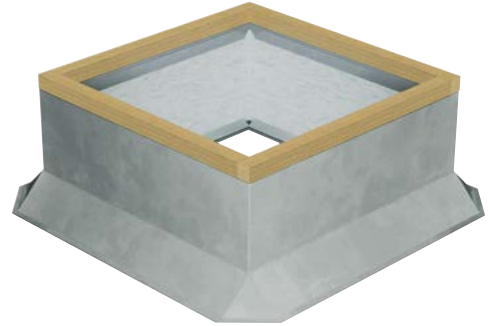

Self-Flashing & Straight-Sided Roof Curbs

- Constructed of 18-gauge galvanized steel with continuously-welded seams
- Wide base plate (flashing) to ensure watertight seal to roof
- Top ledge covered with 3/16" polystyrene gasket (self-flashing) for weather seal and to reduce metal-to-metal conducted noise
- Wood nailer secured to top ledge (straight-sided)
- Lined with 1 1/2" fiberglass fire-resistant, sound-absorbing insulation
- Damper shelf standard
- Straight-sided roof curbs are constructed with the same features as the self-flashing curbs, but are one dimensional to allow for field supplied cants and roofing material to be brought up to the top of the curb
- Options: Aluminum (16-gauge) construction, burglar security bars, metal liner (galvanized or aluminum), special heights up to 24", single- or double-pitched curbs for sloping roofs



Curb Adapters

- Constructed of heavy-gauge galvanized steel with continuously-welded seams
- Top ledge covered with 3/16" polystyrene gasket to reduce metal-to-metal conducted noise and act as a weather seal
- Available in enlarger or reducer (shown) models





NEMA 1 Disconnect Switch



NEMA 3R Disconnect Switch



NEMA 4 Disconnect Switch

Disconnect switches provide positive electrical shutoff during fan cleaning or maintenance.

NEMA 1 Disconnect Switch (Standard)

A NEMA 1 disconnect switch is available shipped loose for field mounting and wiring or factory mounted and wired with ODP or TEFC motors.

NEMA 3R Disconnect Switch

A NEMA 3R, rain proof, disconnect is available shipped loose for field mounting and wiring or factory mounted and wired externally.

NEMA 4 Disconnect Switch

A NEMA 4, water and dust tight, disconnect is available shipped loose for field mounting and wiring or factory mounted and wired externally.

NEMA 7/9 Disconnect Switch

A NEMA 7/9 disconnect switch is recommended on fans with explosion proof motors. The NEMA 7/9 switch is designed for use with fans operating in hazardous environments. Available shipped loose for field mounting and wiring. (Not shown.)



Model DCRD, Direct Drive

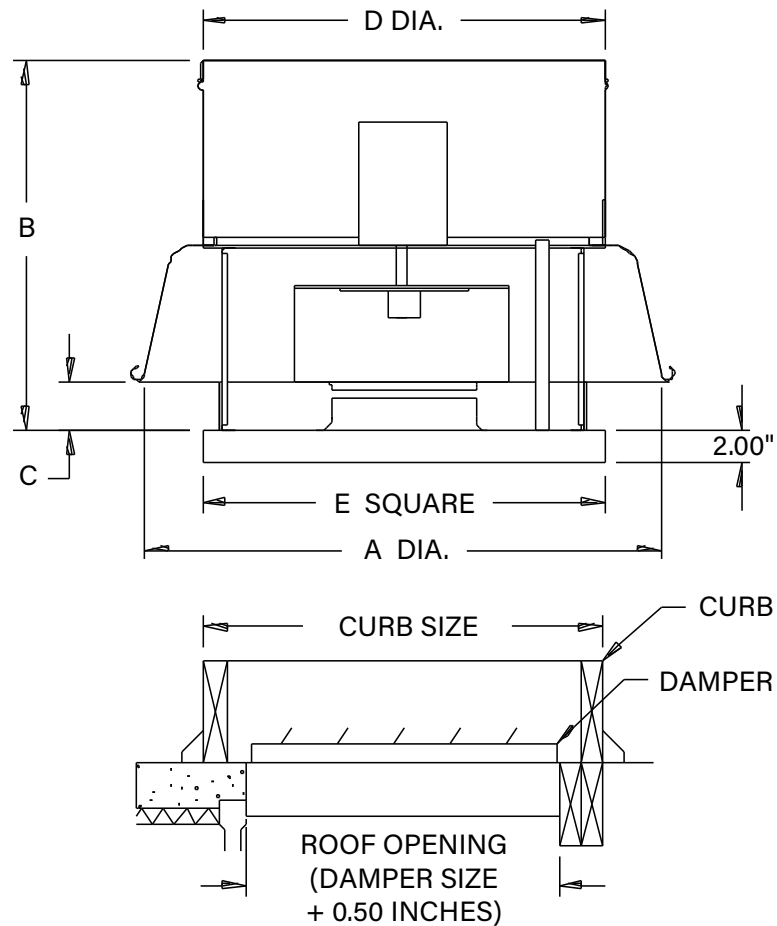

Notes:

1. All dimensions are in inches unless otherwise noted.
2. Dimensions are not to be used for construction.
3. Outside dimensions of dampers are nominal.
4. Outside dimensions of roof curb should be 1" to 1.50" less than inside curb cap dimension 'E', depending on thickness of flashing material used. If curb hinges are used, specify 1.50" difference.
5. Self-flashing roof curbs are 1" larger than canted curbs.

EC MOTOR SIZES	PSC MOTOR SIZES	FAN DIMENSIONS					CANTED CURB SIZE	DAMPER SIZE	AVG. SHIP WT. (LBS.)
		A	B	C	D	E			
120BE	120B	27.50	22.38	3.63	22.00	20.00	18.5x18.5	14x14	50
130BE	130B	27.50	23.25	4.44	22.00	24.00	22.5x22.5	18x18	65
140BE	140B	27.50	23.50	4.69	22.00	24.00	22.5x22.5	18x18	67
150BE	150B	30.44	26.75	4.63	24.00	24.00	22.5x22.5	18x18	77
160BE	160B	30.44	27.25	5.19	24.00	24.00	22.5x22.5	18x18	82
170BE	170B	38.38	29.25	4.06	30.00	30.00	28.5x28.5	24x24	95
180BE	180B	38.38	30.25	5.06	30.00	30.00	28.5x28.5	24x24	100

EC Motor is an Electronically Commutated Motor.
 PSC Motor is a Permanent Split Capacitor Motor.

D-4051F

DIMENSIONS NOT TO BE USED FOR CONSTRUCTION. CERTIFIED DRAWINGS AVAILABLE UPON REQUEST.

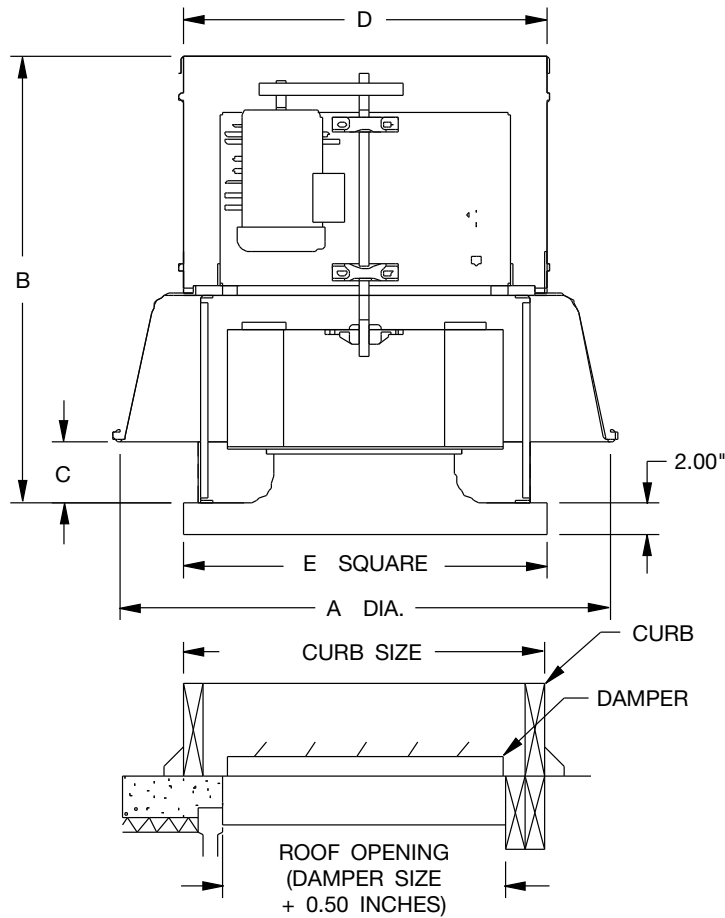

Notes:

1. All dimensions are in inches unless otherwise noted.
2. Dimensions are not to be used for construction.
3. Outside dimensions of dampers are nominal.
4. Outside dimensions of roof curb should be 1" to 1.50" less than inside curb cap dimension 'E', depending on thickness of flashing material used. If curb hinges are used, specify 1.50" difference.
5. Self-flashing roof curbs are 1" larger than canted curbs.

SIZE	FAN DIMENSIONS					CANTED CURB SIZE	DAMPER SIZE	AVG. SHIP WT. (LBS.)
	A	B	C	D	E			
070D/075D	25.88	22.13	2.06	22.00	17.00	15.5x15.5	10x10	58
085D	27.50	23.94	2.38	22.00	17.00	15.5x15.5	10x10	67
100D/100DHP	27.50	23.94	2.38	22.00	20.00	18.5x18.5	14x14	74
120D	30.44	28.13	2.56	24.00	20.00	18.5x18.5	14x14	78
140D	30.44	28.25	2.81	24.00	24.00	22.5x22.5	18x18	93
140DHP	30.44	28.25	2.81	24.00	24.00	22.5x22.5	18x18	88
160D/160DHP	32.63	29.00	3.38	24.00	26.00	24.5x24.5	20x20	107
180D/180DHP	38.38	33.88	3.75	30.00	30.00	28.5x28.5	24x24	130
210D/210DHP	38.38	34.06	4.00	30.00	30.00	28.5x28.5	24x24	160
240D/240DHP	43.13	35.88	4.88	30.00	34.00	32.5x32.5	28x28	220
300D/300DHP	51.38	38.88	4.88	42.00	40.00	38.5x38.5	34x34	270
360D/360DHP	60.75	44.38	6.88	50.00	46.00	44.5x44.5	40x40	360
420D	65.81	47.81	7.00	50.00	52.00	50.5x50.5	46x46	420
480D	74.06	50.25	7.75	58.00	58.00	56.5x56.5	50x50	475

D-4105G

DIMENSIONS NOT TO BE USED FOR CONSTRUCTION. CERTIFIED DRAWINGS AVAILABLE UPON REQUEST.



Model DCRD

Roof exhaust fans shall be of the direct drive centrifugal type, Model DCRD, as manufactured by Twin City Fan & Blower, Minneapolis, Minnesota.

PERFORMANCE — Fans shall be tested in accordance with AMCA 210 and AMCA 300 test codes for air moving devices and shall be guaranteed by the manufacturer to deliver rated published performance levels. Fans shall be licensed to bear the AMCA certified ratings seal for both sound and air. Models shall be cULus 705 listed.

CONSTRUCTION — Model DCRD fan housings shall be constructed of aluminum for durability and appearance. Fan spinings shall have a rolled bead edge for rigidity. Units shall have a deep venturi inlet to prevent snow and rain entry into the building. The curb cap shall include prepunched mounting holes for ease of installation. A conduit chase constructed of electrical metallic tubing shall be provided to the motor compartment. The curb cap shall provide protection from weather. Fans shall bear a permanently attached nameplate displaying model and serial number of the unit for future identification.

MOTOR ASSEMBLY — Motor assembly shall be mounted on vibration isolators to eliminate vibration and noise transmission into the ductwork. Motors shall be mounted out of the exhaust airstream.

IMPELLER — Fan impellers shall be of the centrifugal backward inclined type, containing a matching inlet venturi for optimum unit performance. Impellers shall be statically and dynamically balanced.

MOTOR — Motors shall be heavy-duty ball bearing type, closely matched to the fan load. All single-phase ODP motors shall contain thermal overload protection. All motors shall be UL and /or CSA recognized. Motors for use with speed control shall provide good speed controllability without any objectionable noise.

DISCONNECT SWITCH — A NEMA 1 disconnect switch shall be supplied with wiring leading from the motor to the junction box (ODP and TEFC motors).

FINISH AND COATING — Fans shall be constructed of aluminum. The entire fan assembly, excluding the shaft, shall be properly washed and pretreated before application of a rust-preventative primer, if called out on the order. After the fan is completely assembled, a finish coat of paint shall be applied to the entire assembly, if called out on the order. The fan shaft shall be coated with a petroleum-based rust protectant.

ACCESSORIES — When specified, accessories such as backdraft damper, roof curb, curb hinge, retaining chain, security hasp, variable speed controller, NEMA 3R or NEMA 4 disconnect switches, firestat, aluminum bird screen, aluminum insect screen and special coatings shall be provided by Twin City Fan & Blower to maintain one source responsibility.

FACTORY RUN TEST — All fans prior to shipment shall be completely assembled and test run as a unit at operating speed or maximum RPM allowed for the particular construction type. Each impeller shall be statically and dynamically balanced in accordance with ANSI/AMCA 204-96 "Balance Quality and Vibration Levels for Fans" to Fan Application Category BV-3, Balance Quality Grade G6.3. Balance readings shall be taken by electronic type equipment in the axial, vertical and horizontal directions on each of the bearings. Records shall be maintained and a written copy shall be available upon request.





Model BCRD

Roof mounted exhaust fans shall be of the belt driven centrifugal type, Model BCRD (Spun Aluminum Housing) and as manufactured by Twin City Fan & Blower, Minneapolis, Minnesota.

PERFORMANCE — Fans shall be tested in accordance with AMCA 210 and AMCA 300 test codes for air moving devices and shall be guaranteed by the manufacturer to deliver rated published performance levels. Fans shall be licensed to bear the AMCA certified ratings seal for both sound and air. Models shall be cULus 705 listed.

CONSTRUCTION — Model BCRD fan housings shall be constructed of spun aluminum and shall offer finish durability and aesthetic appearance. Fan spinings shall have a rolled bead edge for rigidity. All units have a deep venturi inlet to prevent snow and rain entry into the building. The curb cap shall include prepunched mounting holes for ease of installation. A conduit chase constructed of electrical metallic tubing shall be provided to the motor compartment. The curb cap shall provide protection from weather. Lifting lugs shall be provided inside the motor compartment for ease of handling and installation. Fans shall bear a permanently attached nameplate displaying model and serial number of the unit for future identification.

MOTOR AND DRIVE ASSEMBLY — Motor and drive assembly shall be mounted on vibration isolators to eliminate vibration and noise transmission into the ductwork. Motors and drives shall be mounted out of the exhaust airstream.

IMPELLER — Fan impellers shall be of the centrifugal backward inclined type, containing a matching inlet venturi for optimum unit performance. Impellers shall be statically and dynamically balanced.

SHAFT — Fan shafts shall be precision-ground and polished. Shafts shall have a first critical speed of at least 125% of the fan's maximum operating speed.

BEARINGS — Bearings shall be of the one-piece, pillow block type with relubricable zerk fittings. Bearings shall be designed for air handling service with a minimum L-10 life in excess of 100,000 hours; L-50 500,000 hours at the maximum cataloged operating speed. Bearing mounting plate shall have self-aligning tabs for exact locating and alignment of bearings.

DRIVE — Drive assembly shall be constructed of heavy-gauge galvanized steel. Drives shall be sized for a minimum of 150% of driven horsepower. Machined, cast iron motor sheaves shall be adjustable for final system balance.

MOTOR — Motors shall be heavy-duty ball bearing type, closely matched to the fan load. All single-phase ODP motors shall contain thermal overload protection. All motors shall be UL and /or CSA recognized. Motor adjustment shall allow precise belt tensioning for optimum belt life and one-person adjustment and servicing.

DISCONNECT SWITCH — A NEMA 1 disconnect switch shall be supplied with wiring leading from the motor to the junction box (ODP and TEFC motors).

FINISH AND COATING — Fans shall be constructed of aluminum. The entire fan assembly, excluding the shaft, shall be properly washed and pretreated before application of a rust-preventative primer, if called out on the order. After the fan is completely assembled, a finish coat of paint shall be applied to the entire assembly, if called out on the order. The fan shaft shall be coated with a petroleum-based rust protectant.

ACCESSORIES — When specified, accessories such as backdraft damper, roof curb, curb hinge, retaining chain, security hasp, NEMA 3R or NEMA 4 disconnect switches, two-speed switch, firestat, aluminum bird screen, aluminum insect screen and special coatings shall be provided by Twin City Fan & Blower to maintain one source responsibility.

FACTORY RUN TEST — All fans prior to shipment shall be completely assembled and test run as a unit at operating speed or maximum RPM allowed for the particular construction type. Each impeller shall be statically and dynamically balanced in accordance with ANSI/AMCA 204-96 "Balance Quality and Vibration Levels for Fans" to Fan Application Category BV-3, Balance Quality Grade G6.3. Balance readings shall be taken by electronic type equipment in the axial, vertical and horizontal directions on each of the bearings. Records shall be maintained and a written copy shall be available upon request.

THIS PAGE INTENTIONALLY LEFT BLANK



INDUSTRIAL PROCESS AND COMMERCIAL VENTILATION SYSTEMS

CENTRIFUGAL FANS | UTILITY SETS | PLENUM & PLUG FANS | INLINE CENTRIFUGAL FANS
MIXED FLOW FANS | TUBEAXIAL & VANEAXIAL FANS | WALL MOUNTED FANS | ROOF VENTILATORS
CENTRIFUGAL ROOF & WALL EXHAUSTERS | CEILING VENTILATORS | GRAVITY VENTILATORS | DUCT BLOWERS
RADIAL BLADED FANS | RADIAL TIP FANS | HIGH EFFICIENCY INDUSTRIAL FANS | PRESSURE BLOWERS
LABORATORY EXHAUST FANS | FILTERED SUPPLY FANS | MANCOOLERS | FIBERGLASS FANS | CUSTOM FANS



TWIN CITY FAN & BLOWER
WWW.TCF.COM

5959 TRENTON LANE N. | MINNEAPOLIS, MN 55442 | PHONE: 763-551-7600 | FAX: 763-551-7601

©2002-2026 Twin City Fan Companies, Ltd., Minneapolis, MN. All rights reserved. Catalog illustrations cover the general appearance of Twin City Fan & Blower products at the time of publication and we reserve the right to make changes in design and construction at any time without notice.