

TEV-745-60

The Energy saving Ventilator

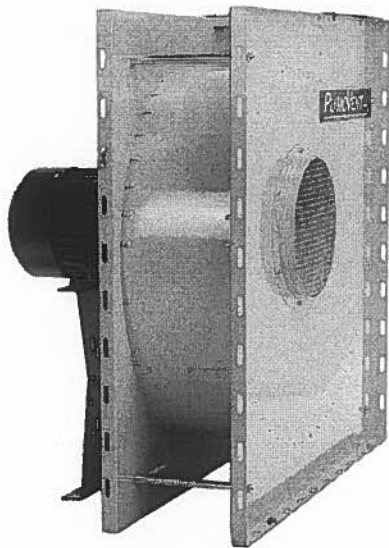

EASY ACCESS IMPELLER

All PlymoVent fan housings are designed for easy access to the impeller. Our design allows an installer or service technician to remove the motor and impeller wheel without removing inlet or outlet duct-work or disassembling the fan housing. It also provides the installer the option of separating the fan into two pieces when mounting in confined locations above drop ceilings or tight access ways.

AIRFOIL IMPELLER

PlymoVent in co-operation with an internationally recognized university, has designed the ultimate airfoil fan impeller. Through the use of aerospace design techniques, PlymoVent has been successful in designing a fan impeller that maximizes air delivery at higher static pressures and reduces energy consumption at the same time. PlymoVent fans deliver the air volume you need at 30% less energy required over any competitive fan.

ENERGY CONSERVATION

PlymoVent's mission is to design energy efficient products. PlymoVent utilizes as standard equipment Energy Efficient Motors. This standard in conjunction with our new design produces the lowest operating cost fan package offered in the world today. If you have an existing fan, you can replace it with a PlymoVent and reduce your operating costs and in turn receive a return on your investment. Not many other products can stand behind that claim.

POWER CONSUMPTION

PlymoVent fans require less kW versus air volume delivered. This does not only equate to less power consumption but also less installation cost. This allows the electrical installer to reduce the cost of installation by reducing the associated components required to run the motor.

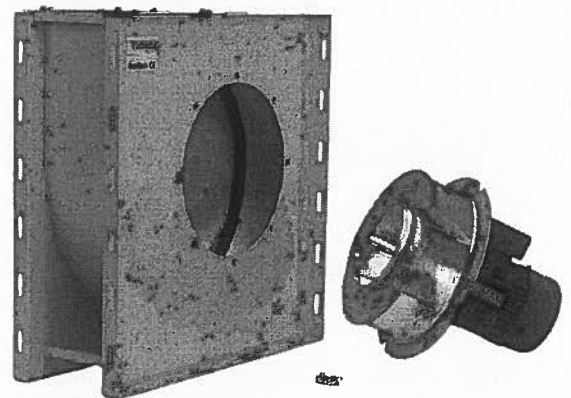

www.plymovent.com



PLYMOVENT[®]
INTELLIGENT PROCESS VENTILATION™

Plymovent Corporation certifies that the product shown herein is licensed to bear the AMCA Seal. The ratings shown are based on tests and procedures performed in accordance with AMCA Publication 211 and AMCA Publication 311 and comply with the requirements of the AMCA Certified Ratings Program.

PlymoVent reserves the right to make design and technical changes.

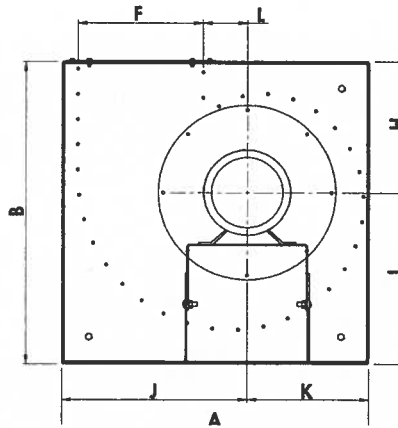
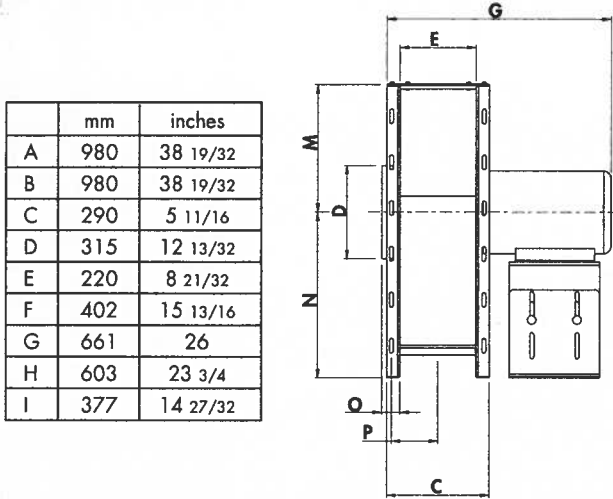

	mm	inches
A	980	38 19/32
B	980	38 19/32
C	290	5 11/16
D	315	12 13/32
E	220	8 21/32
F	402	15 13/16
G	661	26
H	603	23 3/4
I	377	14 27/32

	mm	inches
J	583	22 15/16
K	397	15 5/8
L	140	5 1/2
M	377	14 27/32
N	603	23 3/4
O	41	1 5/8
P	145	5 11/16

TECHNICAL DATA

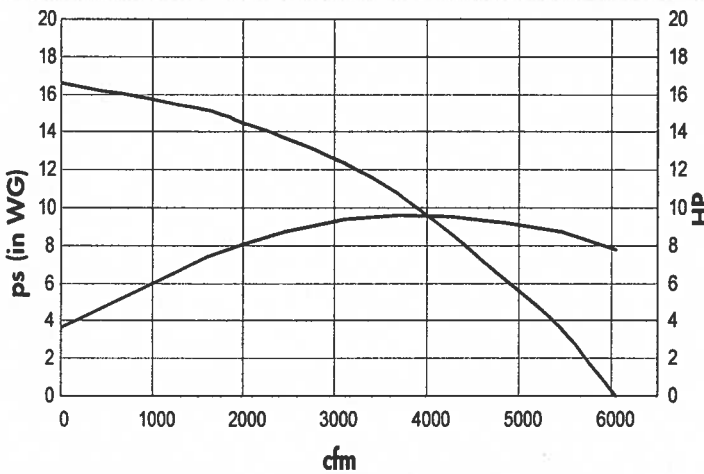

Performance shown is for installation type D: Ducted inlet, Ducted outlet. Performance ratings do not include the effects of appurtenance in the airstream. Performance measured at a speed of 3500 RPM and the efficiency of the motor.

Fan specifications

- Construction: AMCA Type - B
- Drive type: Direct drive
- Impeller type: Backward incline
- Impeller material: Aluminum
- Impeller diameter: 9.7 inch
- Impeller width: 1.8 inch
- Hub size: 1 3/8 inch
- Discharge style: Rotational 90°
- Shaft seal: Rubber
- Housing material: Galvanized steel
- Housing finish: Epoxy powder coat
- Total fan weight: 290 lbs

Motor specifications

- Frame size: NEMA 215TC
- Motor type: TEFC (IP 55)
- Rated output: 10 HP
- Thermal protection: No
- CSA: Yes
- CE-listed: Yes
- Continuous duty: 104°F/40°C
- 3 phase motor**
- Voltage: 208-230/460 V
- Full load current: 25.8-23.4/11.7A
- Motor RPM: 3500
- Service factor: 1.25
- 1 phase motor**
- Voltage: 208-230V
- Full load current: 40.0/20.0A
- Motor RPM: 3500
- Service factor: 1.15

Electrical power is available for all international electrical power sources.

SOUND POWER DATA

Speed	Pressure in wg	Octave Band (Hz)								LwA
		63 Hz	125 Hz	250 Hz	500 Hz	1000 Hz	2000 Hz	4000 Hz	8000 Hz	
3500	0	106	106	104	100	95	94	93	89	103
3500	2	107	106	103	99	94	93	92	88	102
3500	4	107	106	103	99	93	92	90	86	101
3500	6	107	106	102	98	92	90	88	85	100
3500	8	107	105	101	98	92	90	87	84	100

Performance shown is for installation type D: Ducted inlet, Ducted outlet. The sound power level ratings shown are in decibels, referred to 10-12 watts calculated per AMCA standard 301. Values are shown for inlet LwA sound power levels for installation Type D: ducted inlet, ducted outlet. Ratings include the effects of duct end correction.



PlymoVent Corp.
 375 Raritan Center Parkway,
 Edison, New Jersey 08837, USA
 Tel: (732) 417 0808,
 Fax: (732) 417 1818
 www.plymovent.com
 info@plymoventusa.com

PlymoVent Inc.
 6615 Ordan Drive, Unit # 3,
 Mississauga, Ontario L5T 1X2, Canada
 Tel: (905) 564 4748,
 Fax: (905) 564 4609
 www.plymovent.com
 info@plymovent.ca

PlymoVent representative

