

GSLD

SINCE 1975



AMCA & 고효율 송풍기 With GS Fan! Since 1975. 고객과 함께 걸어온 40여년! 고맙습니다. 100년 기업으로 만들겠습니다.

(주)금성풍력은 1975년 설립되어 40여년간 송풍기 제조 외길을 걸어온 장수 기업입니다.
서울 청계천 공구상가에서 1평 남짓 한 점포에서 "동일공사"라는 상호로 출발하여
지금의 남동공단에 2014년 말 기준 임직원 100여명, 년매출 210여억원을 생산하는
송풍기 분야 선도 기업으로서, 국산품 중 최고의 품질로 고객에게 보답 하고 있습니다.
국내 전 산업분야 및 송풍기가 사용 되어지는 현장이라면 금성풍력 송풍기가
한번쯤은 적용 될 정도로 40여년 이라는 세월과 역사가 이미 증명 하고 있습니다.

국내 최초 (美)AMCA 인증 획득. Fan Select 프로그램 또한 고객 여러분과 함께 호흡한 결과물 입니다.
외산 제품과 성능 우위를 겨루며 중소기업 진흥을 통하여 국가산업발전에 이바지한 공헌으로
2012년 5월 17일 대통령 표창을 수상 하였고 2013년 4월 22일 각 분야에서 선도적 위치에 있으며
사회적 책임 수행에도 모범을 보이는 자랑스러운 중소기업인 상을 수상하였습니다.

국내 열악한 송풍기 시장에서 40여년 가까이 송풍기 외길을 걸어 올 수 있었던 것은
고객 여러분의 관심과 애정의 결과물 입니다.
감사합니다. 앞으로도 GsFan은 기술, 연구 개발에 끊임없이 노력하는 기업이 되겠습니다.
고객 여러분! 실망 시키지 않겠습니다!
감사합니다.

2015. 10. (株)金星風力 代表理事 鄭 東 騎 拜上

www.gsfan.co.kr

연혁 HISTORY

- 1975.05 서울 중구 입정동 5-5에 동일공사 창립
- 1979.02 금성풍력 상호변경
- 1992.05 남동공단 2단지 99-8 본사 · 공장 신축이전
- 1996.05 Air Foil Fan 양산 체제 구축
- 1998.02 송풍기선정프로그램 국내 최초 개발
- 1998.12 품질보증시스템인증 획득(ISO 9001/KSA 9001)
- 2001.10 (주)금성풍력 법인전환
- 2002.09 ISO 9001 : 2000전환 인증획득
- 2004.07 남동공단 2단지 98B-11L 본사 · 공장 이전
- 2005.03 (美)AMCA Air Performance(성능) 인증획득 (국내최초 국산 기술)
- 원심형 송풍기(SIROCCO & AIR FOIL FAN) 인증 (편흡입 & 양흡입)
- 2007.03 송풍기 선정 프로그램 업그레이드 (Ver. 8.0)
- 2009.01 (美)AMCA Sound & Air Performance(소음 & 성능) 인증획득
- 원심형 송풍기(SIROCCO & AIR FOIL FAN) 인증 (편흡입 & 양흡입)
- 2010.12 (美)AMCA Sound & Air Performance(소음 & 성능) 인증획득
- MIXED FLOW(DUCT IN LINE) FAN 인증
- 2015.03 송풍기 선정 프로그램 업그레이드 (Ver. 10)



수상내역 AWARD RECORDS

- 2011.01 조선일보-IBK-잡월드 3社 주관. "일하기 좋은 600대 기업 선정"
- 2011. 1. 1. 조선일보 참조
- 2011.05 제3회 명문장수기업상 선정
- 2011.09 지식경제부장관 경영생산성 선도적 활동 표창장
- 2011.09 지식경제부장관 생산성향상 우수한 경영 성과를 거둔 우수기업 지정
- 2011.11 인천광역시 비전기업 선정
- 21C경제주역 「대한민국의 심장, 경제수도 인천」 건설대표브랜드기업, 「비전기업」 선정
- 2012.03 제 39회 상공의 날 대한상공회의소 표창장 (상공업 발전에 기여)
- 2012.05 제 24회 전국중소기업인대회 대통령 표창 (모범 중소기업인)
- 2012.12 인천광역시 중소기업인대상 우수상
- 2013.04 이달의 자랑스러운 중소기업인상 (중소기업중앙회)

TECHNOLOGY



ISO인증은?

기업의 제품 및 서비스 실현 시스템에 대한 품질경영시스템(QMS: Quality Management System)을 규정한 국제인증규격으로 1987년에 국제표준화기구(ISO)가 제정하였습니다. ISO 9000인증은 구입자 측면에서 볼 때 제품의 품질을 조금 더 확실하게하기 위해 공급자가 제조 및 서비스 과정에서 품질을 확실하게 조성할 것을 요구함으로써, 품질관리의 요구사항을 규격으로 정한 제도입니다. 당사는 개발, 설계, 제조, 제품설치, A/S까지 전 과정을 대상으로 한 ISO 9001을 인증 받았습니다.



고효율에너지기자재 인증은?

지식경제부 (고효율에너지기자재 보급 촉진에 관한 규정)에 의하여 에너지 관리공단에서 고효율 에너지 기자재로 인증받은 제품을 말하며 고효율 에너지 기자재의 보급을 활성화 하기 위하여 일정기준 이상 제품에 대하여 인증하여 주는 효율 보증제도입니다.



FAN SELECTION PROGRAM은?

1998년 2월 Ver 1.0으로 개발, 매년 upgrade하여 설비&설계 엔지니어, 유체기계 전공학생 등 고객의 요청에 의거 중소기업 여건에서 연구개발비를 과감하게 투자하여 현재 당사 및 설비&설계사무소(설비관련 Big User)의 엔지니어와 Fan제조사 엔지니어가 활용하고 있습니다. 본 Program은 당사 Home Page에서 무상 다운로드하여 사용가능합니다.



KARSE SEAL

한국설비기술협회(KARSE)에서 AMCA 210, KS B 6311 과 KARSE 송풍기 성능인증 프로그램의 시험과 절차에 따라 성능(풍량, 정압, 축동력)을 검증하여 제품 카다로그의 데이터를 보증해 주는 인증으로써 당사 Airfoil, Sirocco, Duct In Line등의 제품군에 해당됩니다.

www.gsfan.co.kr



AMCA 란?

AMCA (Air Movement and Control Association) International의 약자로 송풍기, 댐퍼, 루버, 에어커튼, 공기유량 측정 장치, 덕트, 소음기 등의 공기기능, 제어 등과 관련된 시스템의 제조업체들이모인 비영리 협회이다. 국제표준을 이끌고 있는 공인성능 인증기관이며 1917년 설립된 후 약 100여년의 역사를 가지고 있습니다.

송풍기분야 및 공조산업분야에서 국제적인 권위를 인정받고 있으며 AMCA의 제정규격은 ASHRAE (American Society of Heating, Refrigerating and Air-Conditioning Engineers, Inc.: 미국냉난방공조협회) 및 ANSI (American National Standards Institute: 미국 규격협회) 규격으로 채택되어 사용되고 있으며 ISO 및 KS규격에도 채용하여 사용되고 있습니다.

비영리 인증기관으로서 유럽과 아시아에 지부를 두고 있으며 송풍기, 댐퍼, 셔터, 등의 공기조절장치와 시스템에 대한 엄격하고 공정한 테스트를 실시하여 제조사의 카탈로그와 실제 제품과의 성능이 일치하는 제품에 대하여 AMCA Seal부착할 수 있도록 권한을 부여하고 소비자가 안심하고 제품을 선정, 사용할 수 있도록 인증하고 있습니다.

2015년 1월말 현재 전 세계 34개국 330여 업체가 회원사로 등록되어 있습니다.



AMCA SEAL(Sound & Air Performance)인증은?

(美)AMCA Lab에서 소음(dB)과 성능(풍량, 정압, 축동력)을 검증하여 제품 카탈로그상의 데이터를 보증하는 국제적으로 권위 있는 연구기관의 인증서로, (주)금성풍력은 국내 최초 소음과 성능에 대한 인증을 획득했습니다.



AMCA SEAL(FEG)인증은?

미국 AMCA에서는 고객의 송풍기 고효율화 요구에 부응하기 위하여 기존의 성능기준에 효율 요구조건을 추가하여 각 송풍기별 효율등급을 규정하고 제품 카탈로그에 효율을 명시 토록하여 고객이 믿을 수 있는 효율 보증 프로그램을 운영하고 있습니다.

(주)금성풍력은 국내최초 효율등급인증을 위하여 노력하고 있습니다.

SIROCCO FAN GSF-SS series



GSF-FAN의 송풍기는 저 정압에서 다량의 공기 또는 가스를 취급하는데 가장 적합한 송풍기로서 공기의 유동상태가 매우 원활하여 불쾌한 소음, 진동이 없으며, 저속회전으로 베어링의 수명이 길다. 이송풍기의 특징은 저압의 송풍기용으로 대략 10 ~ 50mmAq 정도에 있어서 가장 적합한 모델입니다. 용도로는 일반용 송풍, 항구시스템 공기배출, 건축물 또는 공장의 환기, 냉온방장치, 소형저압용 보일러 송배풍, 기타 가스의 반송 또는 배출에 사용됩니다.

GSF model for the transfer of large amount of air in the low pressure. Flowing state of the air is good. Due to the slow rotational speed low vibration, longer bearing life. As designed for low-pressure fans, the fan is the most suitable for pressure of around 10 ~ 50 mmAq. Used for general ventilation, harbor ventilation, ventilation of building, factory ventilation, air conditioners/heaters, wind of small boilers, conveyance of other gas, air discharge.

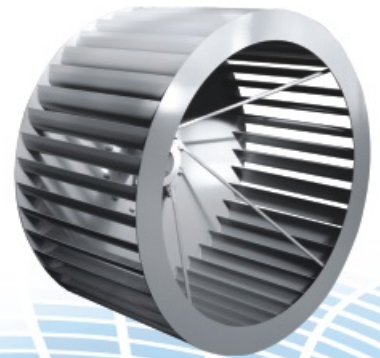

GSF-SS (SWSI CENTRIFUGAL FAN)



GumSung PoongRyuck Co.,LTD. certifies that the GSF-SS Fan Series shown herein is licensed to bear the AMCA Seal. The ratings shown are based on tests and procedures performed in accordance with AMCA Publication 211 and AMCA Publication 311 and comply with the requirements of AMCA Certified Ratings Program.



From GSF-2SS to GSF-14SS for the entire model to have been certified by AMCA for Air performance, sound and FEG ratings.

GSF-2SS ~ GSF-2.25SS was created by converting the test results of GSF-2SS
GSF-2.5SS ~ GSF-3.75SS was created by converting the test results of GSF-2.5SS
GSF-4SS ~ GSF-5.5SS was created by converting the test results of GSF-4SS (excluding GSF-4.5SS).
GSF-4.5SS was created by converting the test results of GSF-4.5SS
GSF-6SS ~ GSF-7SS was created by converting the test results of GSF-6SS
GSF-8SS ~ GSF-14SS was created by converting the test results of GSF-8SS

Type GSF-SS SWSI Series

Gumsung GSF-SS SWSI model is double suction-center hang type fan with wheel diameter from 12" to 84" applied by aerodynamic design.

1. Wheels

All wheels are dynamically balanced and designed to perform up to 100% of standard capacity. The wheels are made of carbon steel and generally constructed by spot welding will be applied in case when high speed is required or the air is dusted or wet.

2. HUB

The hub is made of steel casing and can be fixed to shaft with keys and taper bushes.

3. Casing

Constructed of metal sheets and section steel with continuous welding to perform 100% of standard capacity.

4. Inlet Cone

Designed to perform 100% of standard capacity enabling the maximum control. A special care was done to keep the inlet cones from touching other parts to include wheels. It can be easily assembled to the casing with flat washers.

5. Inlet Vane controls

It accurately controls the air flow and change the direction of flow to the wheels. Reduced air volume than outlet damper will provide more economical performance. If you are installing the inlet guide vane damper performance degradation of about 3-5% is caused by the fluid velocity.

GSF-SS series

SIROCCO FAN
www.gsfan.co.kr

표준외형도 Standard shape of SIROCCO FAN(GSF-SS SERIES)

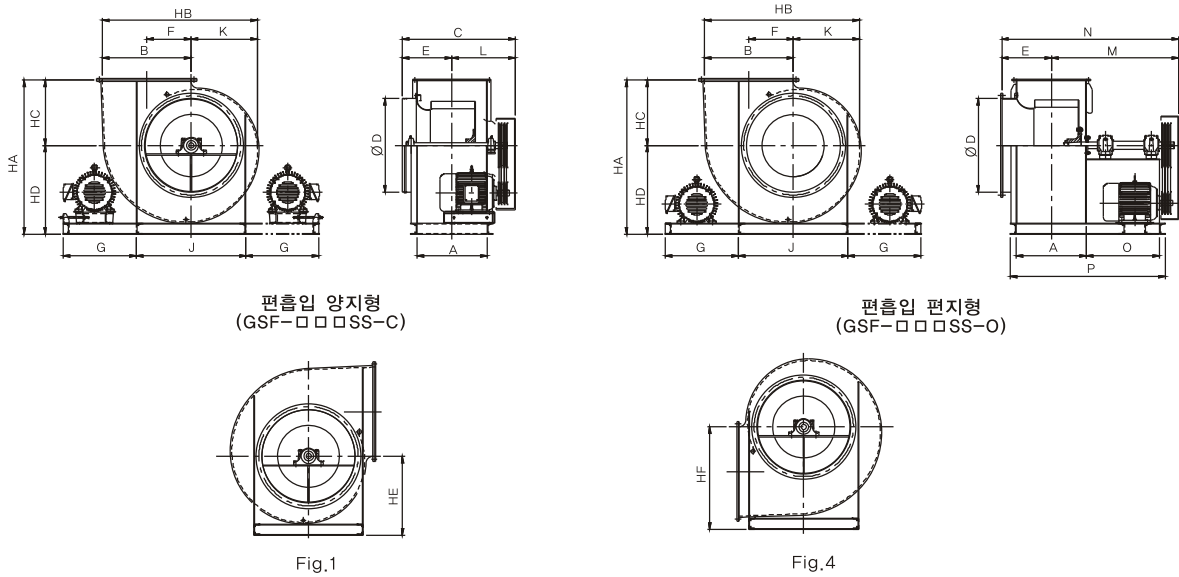

MODEL NO.	A	B	D	E	F	HA	HB	HC	HD	HE	HF	C	J	K	L	M	N	O	P	FAN WEIGHT kg
#2	240	305	320	210	153	550	535	240	310	280	355	495	400	230	285	650	860	400	720	42
#2.25	270	345	360	225	173	630	615	275	355	320	395	525	500	270	300	665	890	400	750	60
#2.5	300	380	400	240	190	660	665	275	385	345	440	555	500	285	315	680	920	400	800	74
#2.75	330	420	440	255	210	760	735	340	420	375	480	585	570	315	330	695	950	400	830	97
#3	360	455	480	280	228	790	795	340	450	400	515	665	570	340	385	710	990	400	860	126
#3.25	390	495	520	295	248	870	870	385	485	435	555	695	660	375	400	725	1020	400	890	143
#3.5	420	535	560	310	268	930	935	410	520	460	595	725	660	400	415	790	1100	450	970	165
#3.75	450	570	600	325	285	1010	1000	430	580	490	630	755	750	430	430	810	1135	455	1005	193
#4	480	610	640	340	305	1060	1065	450	610	540	695	805	750	455	465	870	1210	500	1080	225
#4.25	510	650	680	355	325	1125	1135	480	645	570	735	835	850	485	480	885	1240	500	1110	243
#4.5	540	685	720	370	343	1160	1190	490	670	590	770	865	850	505	495	900	1270	500	1140	268
#5	600	760	800	400	380	1300	1320	540	760	670	870	950	950	560	550	980	1380	550	1250	330
#5.5	660	840	880	430	420	1420	1460	590	830	730	950	1010	1050	620	580	1080	1510	600	1360	393
#6	730	915	960	485	458	1545	1590	650	895	785	1025	1100	1100	675	615	1165	1650	650	1480	462
#6.5	790	990	1040	515	495	1670	1730	700	970	850	1100	1160	1250	740	645	1245	1760	700	1590	535
#7	845	1065	1120	543	533	1790	1850	740	1050	920	1200	1250	1350	785	708	1303	1845	700	1675	608
#8	965	1220	1280	603	610	2060	2120	870	1190	1035	1355	1395	1500	900	793	1463	2065	800	1915	820
#9	1080	1370	1440	660	685	2305	2380	960	1345	1145	1505	1510	1700	1010	850	1520	2180	800	2030	1080
#10	1200	1525	1600	725	763	2530	2650	1050	1480	1285	1685	1635	1900	1125	910	1630	2355	850	2200	1470
#11	1320	1675	1760	810	838	2725	2910	1150	1575	1395	1835	1800	2100	1235	990	1740	2550	900	2370	2100
#12	1440	1830	1920	870	915	2975	3160	1240	1735	1490	1990	1920	2300	1330	1050	1900	2770	1000	2590	2450
#13	1560	1980	2080	930	990	3220	3440	1350	1870	1620	2140	2040	2500	1460	1110	2060	2990	1100	2810	2880
#14	1680	2135	2240	990	1068	3450	3710	1450	2000	1735	2295	2160	2700	1575	1170	2220	3210	1200	3030	3150

※상기 FAN 중량은 모터가 제외한 중량입니다. ※Motor weight was not included in the weight of the fan.

MOTOR BASE

MOTOR	1HP	2HP	3HP	5HP	7.5HP	10HP	15HP	20HP	25HP	30HP	40HP	50HP	60HP	75HP	100HP	125HP	150HP
G	400	400	450	450	500	500	600	600	650	650	700	700	800	800	900	950	1050

※상기 치수 및 성능 DATA는 성능 및 품질 개선을 위해 예고없이 변경할 수 있습니다.

※The dimensions and performance data can change without notice for performance and quality improvement.

팬 선정 방법 예 Fan Selection Example

Impeller overhung on shaft type model name is "GSF-□□□ SS-O".

Impeller mounted on shaft between bearings type model name is "GSF-□□□ SS-C".



그래프 선정 방법

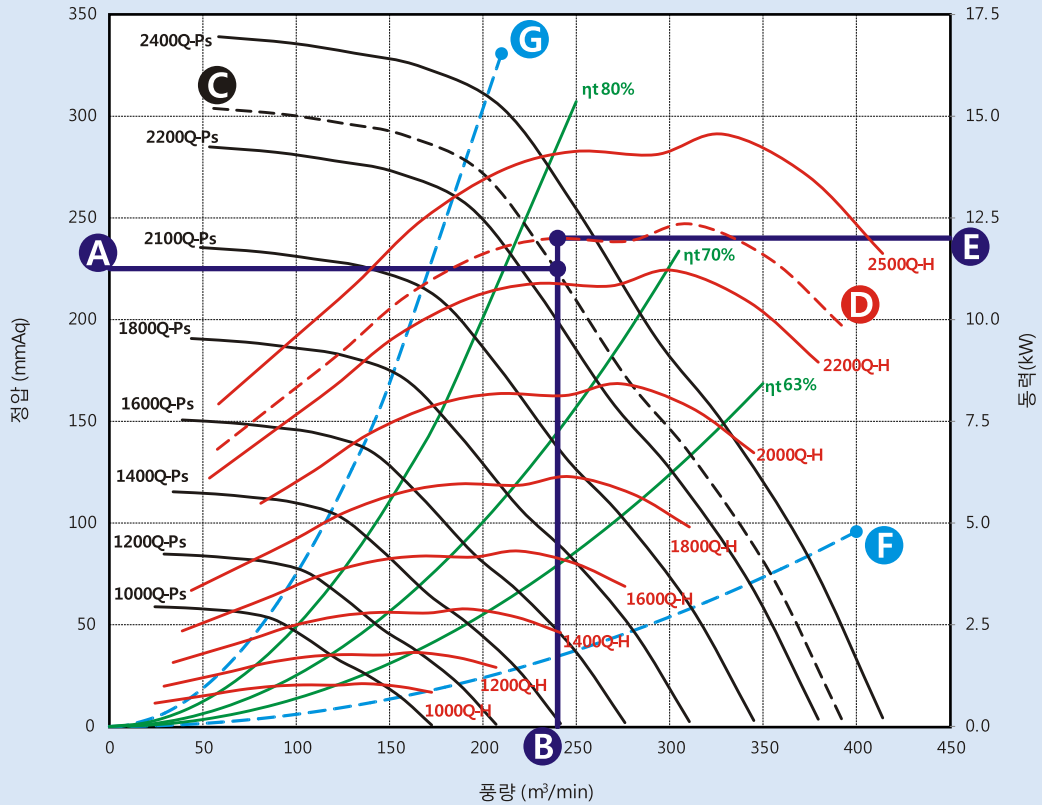

송풍기 사용점 선정방법

1. 요구되는 정압에 해당되는 수평선(A)을 긋는다.
2. 요구되는 풍량에 해당되는 수직선(B)을 긋는다.
3. 요구되는 정압(A) 및 풍량(B)의 교점의 예상회전수 및 예상 풍량압력곡선(C)을 구한다.
4. 예상 회전수에서의 예상동력곡선(D)을 추정한다.
5. 예상동력곡선과 만나는 요구 풍량 수직선의 교점을 동력선 좌표로 수평선(E)을 그린다.
6. 사용 권장 상한선(G)과 사용 권장 하한선(F)를 벗어나는 경우 효율적인 송풍기 운영을 위하여 송풍기 모델 및 기종을 변경하는 것이 바람직하다.

ex) 선정정압 (A) : 225 mmAq
 선정풍량 (B) : 240 m³/min
 선정 정압 및 풍량에 의하여 교점에서 만나는 풍량 압력곡선의 예상회전수(C)는 2272rpm 이다.
 2272 rpm에 해당되는 예상 동력곡선(D)을 그린 후 동력값(E)는 약 11.78kW이다.
 이때의 예상 전압효율은 약 76% 이다.

FAN DESIGN POINT SELECTION

1. Corresponding to the static pressure required horizontal line (A) always draw.
2. Draw a vertical line (B) that corresponds to the required air volume.
3. Calculate the estimated rotational speed and estimated air flow pressure curve (C) of the intersection point of the static pressure (A) and air flow rate (B) is required.
4. Estimates the estimated power curve (D) of the expected number of revolutions.
5. The expected power curve and the intersection of the vertical line corresponding to meet demand airflow to the power line coordinates to draw a horizontal line (E).
6. It is preferred to change the blower model and models for the efficient operation if it is not selected within a blower using the recommended upper limit (G) and using the recommended lower limit (F).

Examples) Selected static pressure(A) : 225 mmAq
 Selected airflow rate(B) : 240 m³/min
 Airflow pressure curve rotation is expected be selected static pressure and air flow (C), meet at the intersection of 2272rpm.
 After drawing the expected power curve (D) corresponding to 2272 rpm for horizontal movement by a power value to meet the intersection of the vertical line and the air flow (E) is about 11.78kW.
 The total efficiency is expected at this point is estimated to be about 76%.

At this time, the selected power is the power consumption of a purely impeller.
 Therefore, when considering the safety factor selected motor and drive loss must be selected and 115-125% larger than the minimum.

GSF-SS series

SIROCCO FAN
www.gsfan.co.kr



GSF-2SS

FEG 60

Wheel dia	300 mm	Tip Speed = 0.01571 * rpm	Outlet Dim'	240 * 305	Outlet Area	0.0732 m ²	Class 1	1783 rpm	Class 2	2005 rpm	Not Applicable
-----------	--------	---------------------------	-------------	-----------	-------------	-----------------------	---------	----------	---------	----------	----------------

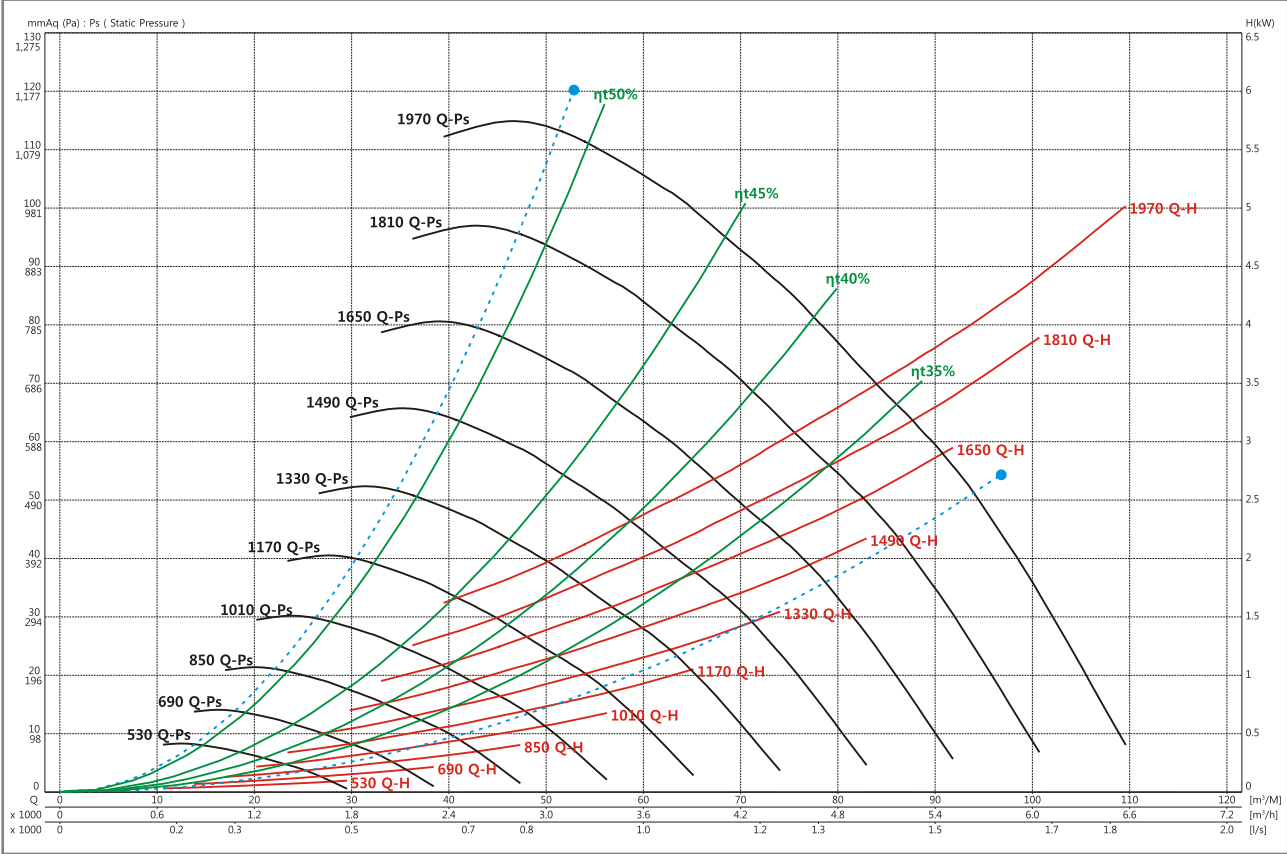

Air flow (m³/min)	Outlet Vel (m/sec)	10 mmAq (98 Pa)				20 mmAq (196 Pa)				30 mmAq (294 Pa)				40 mmAq (392 Pa)				50 mmAq (490 Pa)				
		rpm	BkW	ηt	PWL	rpm	BkW	ηt	PWL	rpm	BkW	ηt	PWL	rpm	BkW	ηt	PWL	rpm	BkW	ηt	PWL	
20	4.55	619	0.08	46.6	65																	
25	5.69	666	0.12	42.2	69	849	0.18	49.0	73													
30	6.83	724	0.17	37.9	72	894	0.25	45.8	76	1039	0.33	49.0	78									
35	7.97	785	0.23	34.0	76	942	0.33	42.2	78	1078	0.42	46.6	80	1200	0.52	49.0	82	1314	0.61	50.4	84	
40	9.11	850	0.32	30.8	79	998	0.43	38.8	81	1126	0.53	43.8	82	1237	0.63	46.8	84	1345	0.73	48.8	85	
45	10.25	918	0.42	28.7	81	1053	0.53	36.2	83	1169	0.64	41.4	84	1286	0.77	44.6	86	1387	0.89	46.8	87	
50	11.38	993	0.55	26.5	84	1111	0.66	34.0	85	1227	0.79	38.8	86	1332	0.92	42.2	87	1437	1.07	44.6	89	
55	12.52	1068	0.70	24.8	86	1183	0.85	31.6	87	1290	0.98	36.2	88	1393	1.13	39.6	89	1485	1.27	42.4	90	
60	13.66	1157	0.92	23.0	88	1253	1.04	29.8	89	1353	1.20	34.0	90	1446	1.33	37.7	90	1533	1.48	40.5	91	
65	14.80	1231	1.13	21.9	90	1325	1.28	27.6	91	1415	1.42	32.5	91	1513	1.61	35.6	92	1594	1.74	38.6	93	
70	15.94	1320	1.42	20.7	92	1397	1.53	26.5	92	1483	1.70	30.8	93	1570	1.87	34.0	94	1657	2.07	36.4	94	
75	17.08	1406	1.73	20.0	94	1480	1.85	25.4	94	1554	2.01	29.3	94	1634	2.19	32.5	95	1717	2.39	34.9	96	

Air flow (m³/min)	Outlet Vel (m/sec)	60 mmAq (588 Pa)				70 mmAq (686 Pa)				80 mmAq (785 Pa)				90 mmAq (883 Pa)				100 mmAq (981 Pa)				
		rpm	BkW	ηt	PWL	rpm	BkW	ηt	PWL	rpm	BkW	ηt	PWL	rpm	BkW	ηt	PWL	rpm	BkW	ηt	PWL	
20	4.55																					
25	5.69																					
30	6.83																					
35	7.97																					
40	9.11	1450	0.86	49.9	87																	
45	10.25	1486	1.02	48.2	88	1575	1.13	49.5	90	1664	1.26	50.3	91									
50	11.38	1525	1.20	46.6	90	1610	1.31	48.0	91	1697	1.46	49.0	92	1781	1.61	49.7	93	1861	1.76	50.3	94	
55	12.52	1575	1.41	44.6	91	1654	1.54	46.3	92	1737	1.70	47.5	93	1816	1.85	48.4	94	1893	2.01	49.1	95	
60	13.66	1621	1.63	42.8	92	1701	1.78	44.6	93	1784	1.97	45.8	94	1854	2.12	47.0	95	1927	2.27	47.9	96	
65	14.80	1679	1.94	40.5	94	1754	2.10	42.4	94	1831	2.26	44.0	95	1901	2.41	45.5	96	1969	2.58	46.6	97	
70	15.94	1733	2.23	38.8	95	1809	2.42	40.7	96	1883	2.61	42.2	96	1950	2.75	43.8	97					
75	17.08	1793	2.58	37.0	96	1867	2.78	39.0	97	1936	2.98	40.5	97									

- Power rating BkW does not include transmission losses.
 - The A-weighted sound ratings shown have been calculated per AMCA International Standard 301. Values shown are for inlet LwA sound power levels for installation type B (free inlet, ducted outlet).
 - Performance certified is for installation type B: free inlet, ducted outlet. Performance ratings do not include the effects of appurtenance (accessories).

GSF-SS series

SIROCCO FAN

www.gsfan.co.kr



GSF-2.25SS

FEG 56

Wheel dia	340 mm	Tip Speed =	0.0178 * rpm	Outlet Dim'	270 * 345	Outlet Area	0.0932 m ²	Class 1	1404 rpm	Class 2	1769 rpm	Not Applicable
-----------	--------	-------------	--------------	-------------	-----------	-------------	-----------------------	---------	----------	---------	----------	----------------

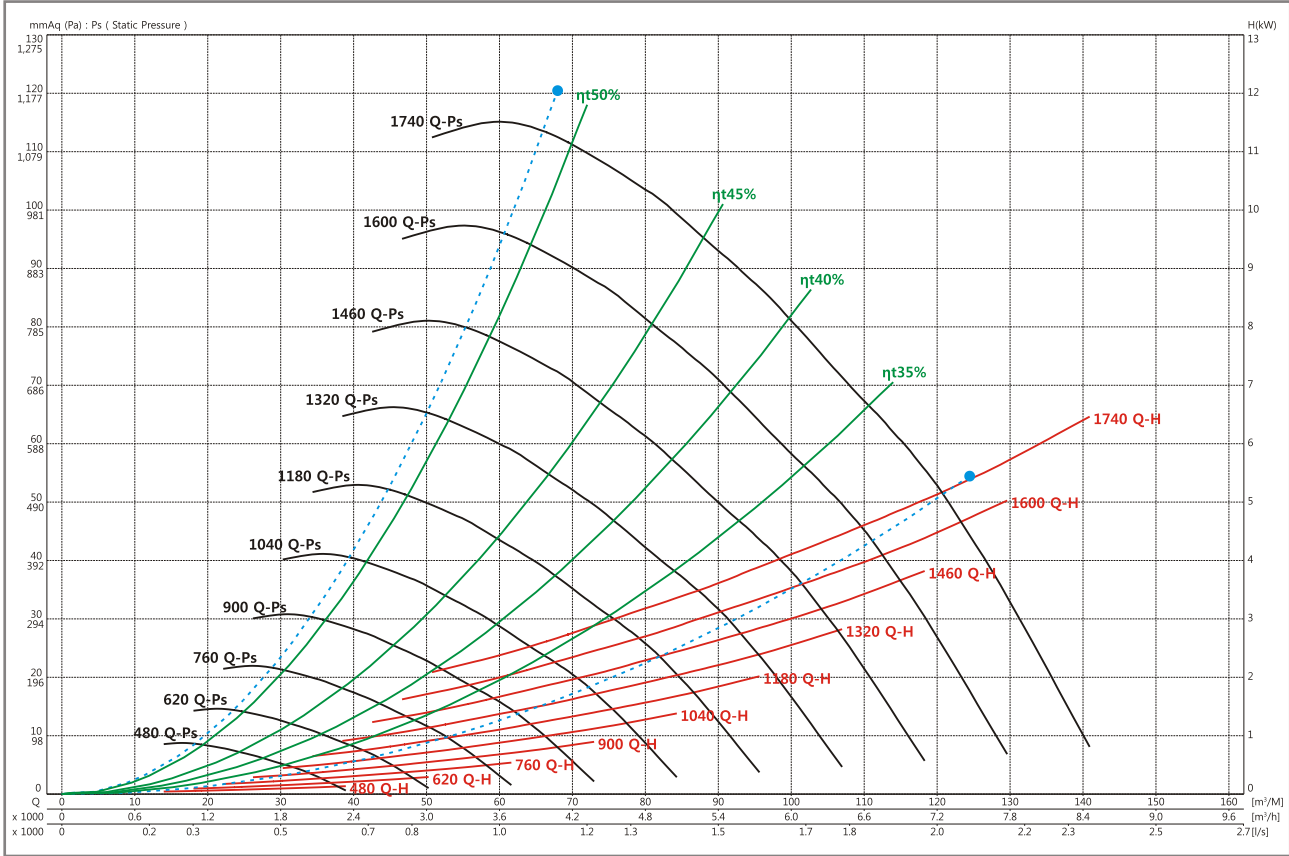

Air flow (m³/min)	Outlet Vel (m/sec)	10 mmAq (98 Pa)				20 mmAq (196 Pa)				30 mmAq (294 Pa)				40 mmAq (392 Pa)				50 mmAq (490 Pa)			
		rpm	BkW	ηt	PWL	rpm	BkW	ηt	PWL	rpm	BkW	ηt	PWL	rpm	BkW	ηt	PWL	rpm	BkW	ηt	PWL
30	5.37	573	0.13	43.8	68	741	0.22	49.7	72												
35	6.26	611	0.18	39.6	71	766	0.27	47.5	74	898	0.37	50.4	78								
40	7.16	651	0.23	37.0	74	794	0.33	45.2	76	920	0.44	48.8	79	1036	0.56	50.5	81				
45	8.05	693	0.30	34.0	76	831	0.42	42.2	78	950	0.53	46.8	81	1059	0.66	49.0	83	1159	0.79	50.4	85
50	8.95	738	0.38	31.6	79	869	0.51	39.6	80	983	0.64	44.6	82	1084	0.77	47.5	84	1183	0.91	49.1	86
55	9.84	789	0.49	29.3	81	910	0.63	37.0	82	1018	0.77	42.2	84	1117	0.91	45.5	85	1208	1.06	47.6	87
60	10.74	837	0.60	27.6	83	946	0.74	35.4	84	1050	0.89	40.5	85	1147	1.05	43.8	87	1234	1.20	46.3	88
65	11.63	887	0.73	26.5	85	992	0.90	33.2	86	1095	1.07	38.1	87	1182	1.21	42.0	88	1268	1.38	44.6	89
70	12.52	936	0.88	24.8	86	1037	1.07	31.6	87	1137	1.25	36.2	88	1222	1.42	39.8	89	1302	1.58	42.8	90
75	13.42	996	1.10	23.0	88	1081	1.23	30.6	89	1178	1.45	34.7	90	1263	1.64	38.1	91	1336	1.80	41.2	91
80	14.31	1055	1.32	22.4	90	1130	1.46	28.7	90	1220	1.67	33.4	91	1302	1.85	36.8	92	1376	2.04	39.6	92
85	15.21	1102	1.51	21.9	91	1184	1.71	27.6	92	1260	1.89	32.3	92	1341	2.10	35.4	93	1420	2.34	37.9	94

Air flow (m³/min)	Outlet Vel (m/sec)	60 mmAq (588 Pa)				70 mmAq (686 Pa)				80 mmAq (785 Pa)				90 mmAq (883 Pa)				100 mmAq (981 Pa)			
		rpm	BkW	ηt	PWL	rpm	BkW	ηt	PWL	rpm	BkW	ηt	PWL	rpm	BkW	ηt	PWL	rpm	BkW	ηt	PWL
30	5.37																				
35	6.26																				
40	7.16																				
45	8.05																				
50	8.95	1272	1.05	50.3	87																
55	9.84	1297	1.22	49.0	88	1378	1.36	50.1	89												
60	10.74	1322	1.38	47.7	89	1401	1.54	49.0	90	1478	1.70	49.9	91	1553	1.87	50.5	93				
65	11.63	1346	1.54	46.6	90	1429	1.75	47.6	91	1502	1.91	48.8	92	1575	2.11	49.5	93	1645	2.29	50.2	94
70	12.52	1385	1.79	44.8	91	1454	1.94	46.6	92	1528	2.14	47.6	93	1600	2.36	48.4	94	1668	2.55	49.2	95
75	13.42	1417	2.01	43.2	92	1486	2.17	45.2	93	1554	2.37	46.6	94	1625	2.60	47.5	95	1693	2.83	48.2	96
80	14.31	1453	2.28	41.6	93	1521	2.46	43.6	94	1589	2.66	45.2	95	1655	2.89	46.3	96	1718	3.11	47.3	96
85	15.21	1487	2.54	40.2	94	1555	2.75	42.2	95	1622	2.96	43.8	96	1685	3.17	45.2	96				

- Power rating BkW does not include transmission losses. GSF-SS Version 11.0_May2024
 - The A-weighted sound ratings shown have been calculated per AMCA International Standard 301. Values shown are for inlet LwiA sound power levels for installation type B (free inlet, ducted outlet).
 - Performance certified is for installation type B: free inlet, ducted outlet. Performance ratings do not include the effects of appurtenance (accessories).

SIROCCO FAN
GSF-SS series

GSF-SS series

SIROCCO FAN

www.gsfan.co.kr



GSF-2.5SS

FEG 63

Wheel dia	375 mm	Tip Speed = 0.01964 * rpm	Outlet Dim'	300 * 380	Outlet Area	0.1140 m ²	Class 1	1273 rpm	Class 2	1604 rpm	Not Applicable
-----------	--------	---------------------------	-------------	-----------	-------------	-----------------------	---------	----------	---------	----------	----------------

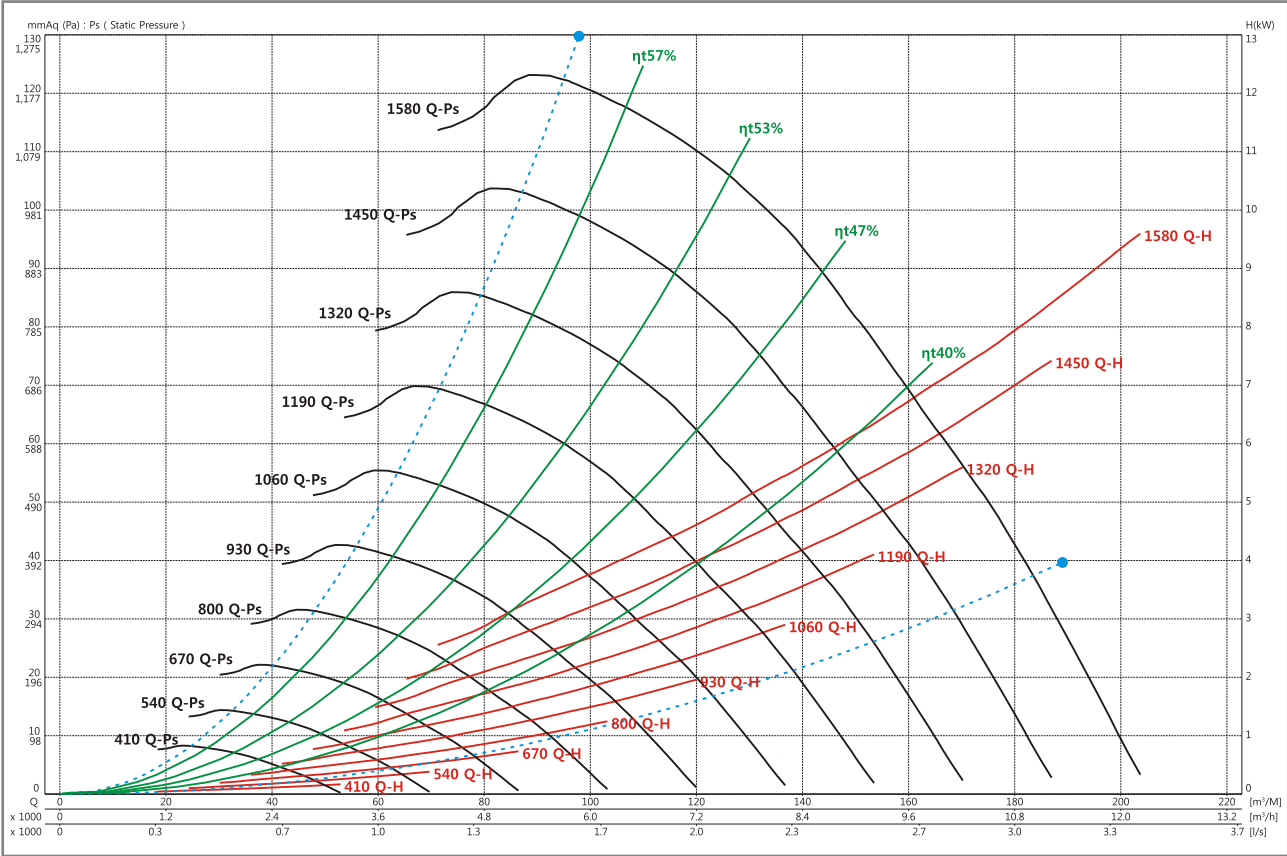

Air flow (m³/min)	Outlet Vel (m/sec)	10 mmAq (98 Pa)				20 mmAq (196 Pa)				30 mmAq (294 Pa)				40 mmAq (392 Pa)				50 mmAq (490 Pa)				
		rpm	BkW	η _t	PWL	rpm	BkW	η _t	PWL	rpm	BkW	η _t	PWL	rpm	BkW	η _t	PWL	rpm	BkW	η _t	PWL	
43	6.29	504	0.18	49.7	69	650	0.28	57.1	75													
50	7.31	540	0.24	45.2	72	669	0.34	55.2	75	788	0.47	57.9	79									
57	8.33	578	0.32	41.8	75	696	0.44	51.7	76	806	0.57	56.2	80	910	0.72	57.9	84					
64	9.36	618	0.41	38.7	77	728	0.55	48.7	79	828	0.67	54.4	80	926	0.83	56.6	84	1017	1.00	57.9	88	
71	10.38	662	0.54	35.9	80	765	0.68	45.5	81	855	0.82	51.5	81	946	0.97	55.2	84	1033	1.15	56.8	88	
78	11.40	702	0.67	34.0	82	801	0.82	43.0	83	891	1.00	48.7	84	974	1.16	52.8	85	1056	1.34	55.3	87	
85	12.43	748	0.83	32.2	84	841	1.01	40.3	85	924	1.18	46.4	85	1001	1.35	50.6	86	1079	1.54	53.5	87	
92	13.45	796	1.04	30.4	86	888	1.24	37.8	87	962	1.39	44.0	87	1034	1.58	48.4	88	1107	1.79	51.3	88	
99	14.47	848	1.28	29.1	88	927	1.46	36.3	88	1001	1.65	41.8	89	1071	1.85	46.1	89	1137	2.04	49.5	89	
106	15.50	896	1.54	27.8	90	969	1.73	34.8	90	1046	1.96	39.6	90	1109	2.14	44.0	91	1172	2.34	47.5	91	
113	16.52	942	1.82	27.0	91	1016	2.04	33.4	92	1089	2.30	37.8	92	1152	2.50	42.1	92	1214	2.74	45.2	92	
120	17.54	996	2.18	26.2	93	1057	2.35	32.2	93	1129	2.63	36.5	93	1189	2.84	40.3	93	1250	3.08	43.7	94	

Air flow (m³/min)	Outlet Vel (m/sec)	60 mmAq (588 Pa)				70 mmAq (686 Pa)				80 mmAq (785 Pa)				90 mmAq (883 Pa)				100 mmAq (981 Pa)				
		rpm	BkW	η _t	PWL	rpm	BkW	η _t	PWL	rpm	BkW	η _t	PWL	rpm	BkW	η _t	PWL	rpm	BkW	η _t	PWL	
43	6.29																					
50	7.31																					
57	8.33																					
64	9.36																					
71	10.38	1115	1.33	57.8	89																	
78	11.40	1132	1.51	56.8	89	1208	1.71	57.7	90	1279	1.91	58.3	91									
85	12.43	1154	1.73	55.6	89	1225	1.93	56.6	90	1296	2.17	57.3	91	1362	2.37	58.0	92					
92	13.45	1179	1.99	53.8	89	1248	2.20	55.4	90	1314	2.43	56.4	91	1379	2.66	57.1	92	1441	2.90	57.7	93	
99	14.47	1206	2.28	51.7	90	1272	2.49	53.9	91	1336	2.71	55.3	92	1397	2.94	56.2	92	1459	3.21	56.9	93	
106	15.50	1237	2.59	49.9	91	1297	2.80	52.1	92	1360	3.05	53.9	92	1420	3.29	55.2	93	1479	3.56	55.9	94	
113	16.52	1269	2.92	48.3	93	1327	3.17	50.4	93	1385	3.40	52.2	93	1444	3.67	53.8	94	1500	3.91	55.0	95	
120	17.54	1306	3.33	46.4	94	1361	3.58	48.7	94	1414	3.81	50.6	94	1470	4.06	52.2	95	1527	4.37	53.5	95	

- Power rating BkW does not include transmission losses.
 - The A-weighted sound ratings shown have been calculated per AMCA International Standard 301. Values shown are for inlet LwiA sound power levels for installation type B (free inlet, ducted outlet).
 - Performance certified is for installation type B: free inlet, ducted outlet. Performance ratings do not include the effects of appurtenance (accessories).
 GSF-SS Version 11.0_May2024

GSF-SS series

SIROCCO FAN
www.gsfan.co.kr



GSF-2.75SS FEG 63

Wheel dia	415 mm	Tip Speed = 0.02173 * rpm	Outlet Dim'	330 * 420	Outlet Area	0.1386 m ²	Class 1	1151 rpm	Class 2	1450 rpm	Not Applicable
-----------	--------	---------------------------	-------------	-----------	-------------	-----------------------	---------	----------	---------	----------	----------------

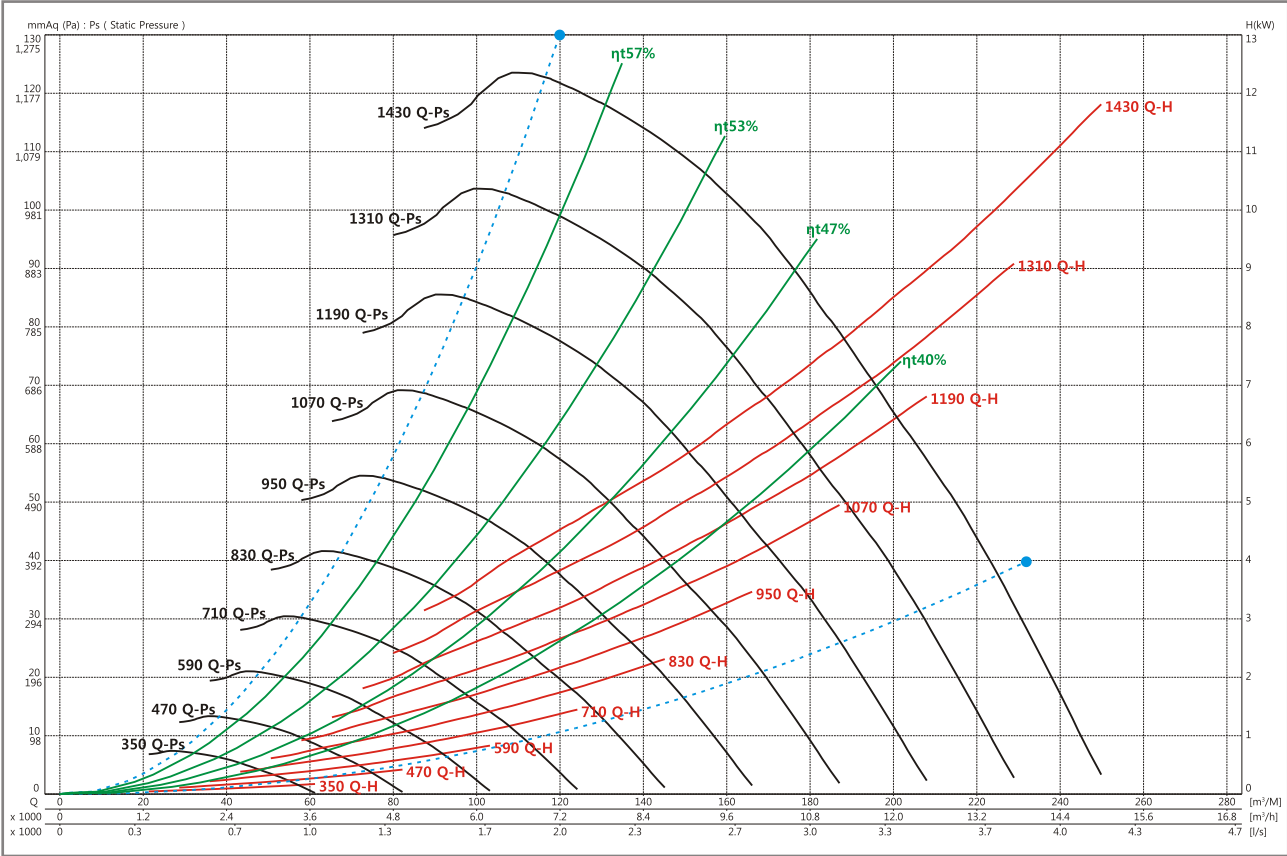

Air flow (m³/min)	Outlet Vel (m/sec)	10 mmAq (98 Pa)				20 mmAq (196 Pa)				30 mmAq (294 Pa)				40 mmAq (392 Pa)				50 mmAq (490 Pa)				
		rpm	BkW	η _t	PWL	rpm	BkW	η _t	PWL	rpm	BkW	η _t	PWL	rpm	BkW	η _t	PWL	rpm	BkW	η _t	PWL	
40	4.81	421	0.13	56.2	68																	
50	6.01	446	0.19	51.5	68	582	0.31	57.9	76													
60	7.22	482	0.28	46.4	72	602	0.41	55.6	76	710	0.56	58.0	80									
70	8.42	523	0.39	41.8	76	630	0.54	51.5	77	729	0.69	56.2	80	822	0.88	57.9	84					
80	9.62	568	0.54	37.8	79	664	0.69	48.4	79	755	0.87	53.8	81	842	1.07	56.2	84	923	1.27	57.7	88	
90	10.82	612	0.71	35.5	81	704	0.9	44.3	82	783	1.07	50.6	83	864	1.27	54.4	85	941	1.49	56.2	88	
100	12.03	660	0.94	32.7	84	744	1.13	41.4	84	820	1.33	47.5	85	893	1.54	51.5	86	966	1.77	54.4	88	
110	13.23	709	1.21	30.8	86	788	1.42	38.7	87	861	1.65	44.3	87	926	1.85	49.0	88	993	2.10	51.9	89	
120	14.43	759	1.51	29.5	88	834	1.76	36.5	89	902	2.00	41.8	89	964	2.22	46.4	90	1024	2.46	49.7	90	
130	15.63	810	1.89	27.8	90	877	2.12	34.8	90	945	2.40	39.6	91	1004	2.64	43.8	91	1061	2.90	47.2	92	
140	16.84	859	2.29	27.0	92	923	2.55	33.2	92	989	2.87	37.5	93	1045	3.11	41.8	93	1102	3.40	45.2	93	
150	18.04	914	2.80	26.2	94	974	3.09	31.5	94	1034	3.39	35.9	94	1092	3.70	39.6	94	1142	3.96	43.0	95	

Air flow (m³/min)	Outlet Vel (m/sec)	60 mmAq (588 Pa)				70 mmAq (686 Pa)				80 mmAq (785 Pa)				90 mmAq (883 Pa)				100 mmAq (981 Pa)				
		rpm	BkW	η _t	PWL	rpm	BkW	η _t	PWL	rpm	BkW	η _t	PWL	rpm	BkW	η _t	PWL	rpm	BkW	η _t	PWL	
40	4.81																					
50	6.01																					
60	7.22																					
70	8.42																					
80	9.62																					
90	10.82	1014	1.72	57.3	91	1083	1.96	58.1	92													
100	12.03	1033	1.99	56.1	90	1100	2.24	57.1	91	1163	2.49	57.9	92	1225	2.76	58.3	93					
110	13.23	1058	2.33	54.4	90	1122	2.61	55.8	91	1181	2.85	56.8	92	1242	3.16	57.3	93	1298	3.41	58.0	94	
120	14.43	1085	2.72	52.1	91	1145	2.98	54.2	92	1203	3.25	55.6	93	1260	3.55	56.4	93	1315	3.85	57.0	94	
130	15.63	1118	3.18	49.9	92	1174	3.47	51.9	92	1230	3.74	53.9	93	1283	4.02	55.2	94	1337	4.36	55.9	95	
140	16.84	1155	3.70	47.8	93	1207	4.00	49.9	94	1259	4.30	51.7	94	1309	4.56	53.5	95	1361	4.90	54.7	95	
150	18.04	1194	4.28	45.6	95	1242	4.55	48.3	95	1291	4.90	49.9	95	1339	5.21	51.5	96	1386	5.49	53.2	96	

- Power rating BkW does not include transmission losses.
 - The A-weighted sound ratings shown have been calculated per AMCA International Standard 301. Values shown are for inlet LwiA sound power levels for installation type B (free inlet, ducted outlet).
 - Performance certified is for installation type B: free inlet, ducted outlet. Performance ratings do not include the effects of appurtenance (accessories).
 GSF-SS Version 11.0_May2024

SIROCCO FAN
GSF-SS series

GSF-SS series

SIROCCO FAN

www.gsfan.co.kr



GSF-3SS

FEG 63

Wheel dia	450 mm	Tip Speed = 0.02356 * rpm	Outlet Dim'	360 * 455	Outlet Area	0.1638 m ²	Class 1	1061 rpm	Class 2	1337 rpm	Not Applicable
-----------	--------	---------------------------	-------------	-----------	-------------	-----------------------	---------	----------	---------	----------	----------------

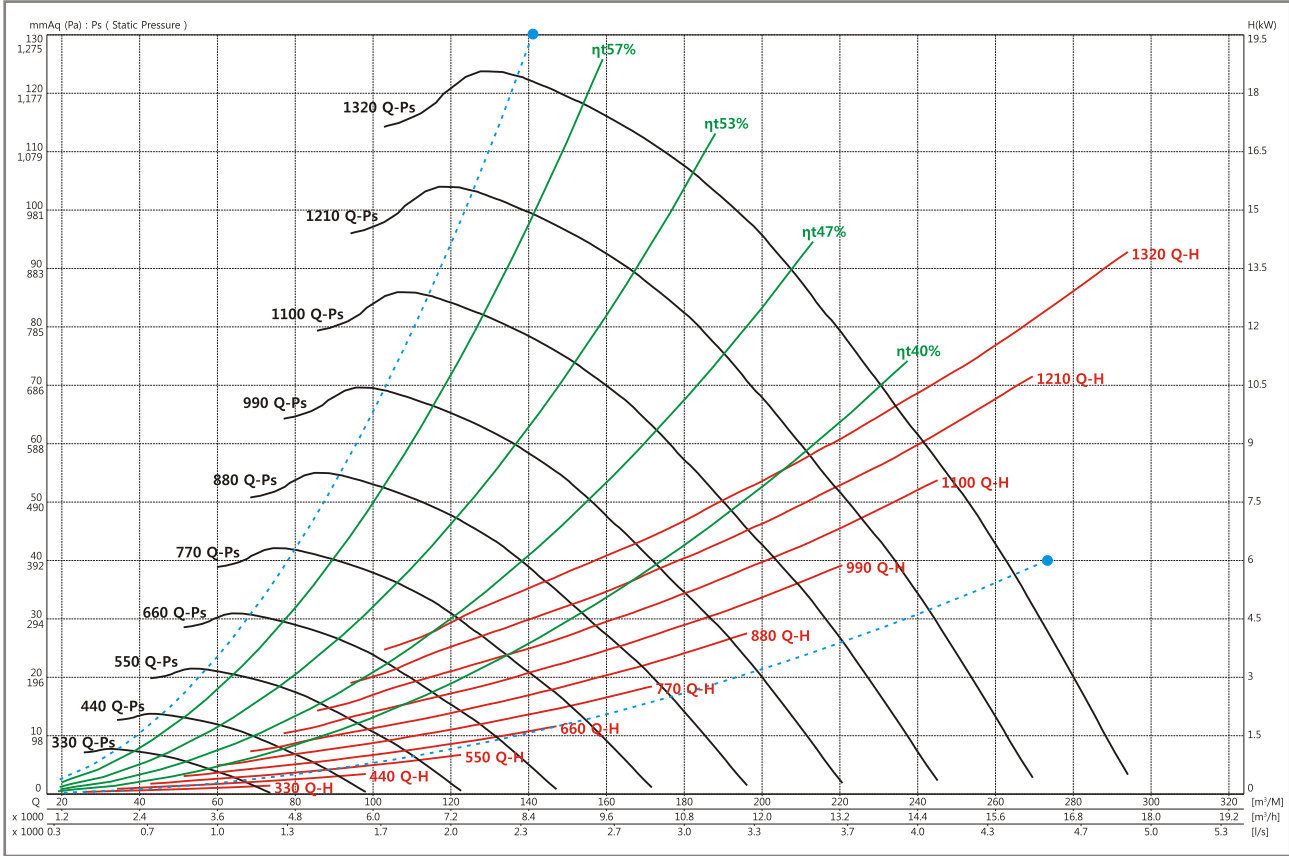

Air flow (m³/min)	Outlet Vel (m/sec)	10 mmAq (98 Pa)				20 mmAq (196 Pa)				30 mmAq (294 Pa)				40 mmAq (392 Pa)				50 mmAq (490 Pa)				
		rpm	BkW	η _t	PWL	rpm	BkW	η _t	PWL	rpm	BkW	η _t	PWL	rpm	BkW	η _t	PWL	rpm	BkW	η _t	PWL	
60	6.11	416	0.24	50.8	69	538	0.38	57.7	78													
70	7.12	444	0.32	46.4	73	554	0.47	55.6	77	655	0.65	58.0	80									
80	8.14	475	0.43	42.7	75	576	0.60	52.5	77	668	0.78	56.6	81	755	0.99	58.1	84					
90	9.16	508	0.56	39.1	78	599	0.74	49.5	79	688	0.95	54.7	81	769	1.17	56.9	84	845	1.40	58.0	87	
100	10.18	545	0.74	36.3	81	629	0.92	46.4	81	709	1.14	51.9	82	786	1.37	55.4	85	858	1.62	56.9	87	
110	11.19	578	0.92	34.4	83	663	1.15	43.3	83	734	1.36	49.5	84	805	1.59	53.5	85	875	1.85	55.8	88	
120	12.21	616	1.15	32.7	85	696	1.41	40.6	85	764	1.64	46.8	86	830	1.90	50.8	86	894	2.13	54.1	88	
130	13.23	655	1.43	30.8	87	728	1.68	38.5	87	797	1.96	44.3	88	857	2.22	48.7	88	918	2.49	51.7	89	
140	14.25	694	1.74	29.5	88	764	2.03	36.5	89	829	2.31	42.1	89	887	2.57	46.7	90	943	2.86	49.9	90	
150	15.26	734	2.09	28.4	90	799	2.39	35.0	91	860	2.68	40.2	91	919	3.01	44.3	91	972	3.30	47.8	92	
160	16.28	774	2.49	27.4	92	834	2.79	33.8	92	895	3.13	38.5	92	949	3.44	42.5	93	1001	3.76	45.9	93	
170	17.30	816	2.97	26.4	93	873	3.29	32.2	94	930	3.63	36.9	94	985	3.99	40.6	94	1033	4.29	44.0	94	

Air flow (m³/min)	Outlet Vel (m/sec)	60 mmAq (588 Pa)				70 mmAq (686 Pa)				80 mmAq (785 Pa)				90 mmAq (883 Pa)				100 mmAq (981 Pa)				
		rpm	BkW	η _t	PWL	rpm	BkW	η _t	PWL	rpm	BkW	η _t	PWL	rpm	BkW	η _t	PWL	rpm	BkW	η _t	PWL	
60	6.11																					
70	7.12																					
80	8.14																					
90	9.16																					
100	10.18	927	1.86	58.0	90																	
110	11.19	942	2.14	56.9	91	1004	2.40	57.9	93	1060	2.68	58.3	94									
120	12.21	958	2.43	55.8	91	1018	2.73	56.8	93	1076	3.02	57.7	94	1132	3.34	58.1	95					
130	13.23	977	2.75	54.4	91	1035	3.07	55.8	93	1092	3.41	56.6	94	1146	3.73	57.3	94	1198	4.06	57.9	95	
140	14.25	999	3.17	52.2	91	1054	3.45	54.4	92	1109	3.80	55.6	94	1161	4.15	56.4	95	1212	4.50	57.1	95	
150	15.26	1024	3.61	50.4	92	1077	3.94	52.5	93	1127	4.22	54.4	94	1178	4.58	55.5	95	1227	4.96	56.2	95	
160	16.28	1051	4.09	48.7	93	1100	4.42	50.8	94	1149	4.78	52.5	94	1198	5.11	54.2	95	1245	5.47	55.3	96	
170	17.30	1081	4.65	46.8	95	1127	4.99	49.2	95	1174	5.37	50.8	95	1220	5.73	52.5	96	1265	6.05	54.1	96	

- Power rating BkW does not include transmission losses.
 - The A-weighted sound ratings shown have been calculated per AMCA International Standard 301. Values shown are for inlet LwiA sound power levels for installation type B (free inlet, ducted outlet).
 - Performance certified is for installation type B: free inlet, ducted outlet. Performance ratings do not include the effects of appurtenance (accessories).

GSF-SS series

SIROCCO FAN
www.gsfan.co.kr



GSF-3.25SS FEG 63

Wheel dia	490 mm	Tip Speed = 0.02566 * rpm	Outlet Dim'	390 * 495	Outlet Area	0.1931 m ²	Class 1	974 rpm	Class 2	1228 rpm	Not Applicable
-----------	--------	---------------------------	-------------	-----------	-------------	-----------------------	---------	---------	---------	----------	----------------

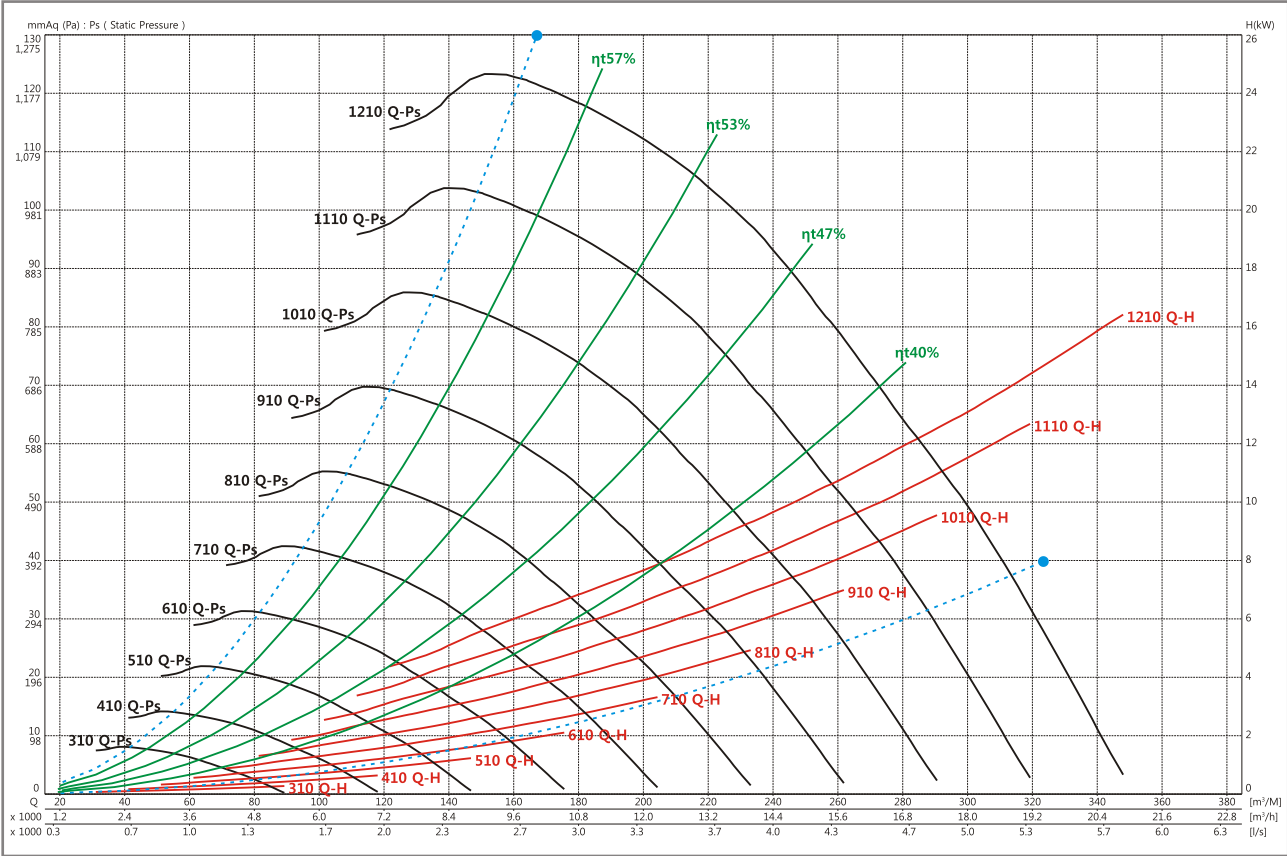

Air flow (m³/min)	Outlet Vel (m/sec)	10 mmAq (98 Pa)				20 mmAq (196 Pa)				30 mmAq (294 Pa)				40 mmAq (392 Pa)				50 mmAq (490 Pa)				
		rpm	BkW	η _t	PWL	rpm	BkW	η _t	PWL	rpm	BkW	η _t	PWL	rpm	BkW	η _t	PWL	rpm	BkW	η _t	PWL	
75	6.48	388	0.31	49.7	70	499	0.48	57.0	80													
87.5	7.55	417	0.42	44.8	74	516	0.61	54.6	78	606	0.83	57.6	82									
100	8.63	451	0.58	40.9	77	538	0.78	51.3	78	621	1.01	55.9	82	699	1.26	57.7	84					
112.5	9.71	484	0.77	37.8	80	565	0.99	47.8	81	640	1.22	53.5	82	713	1.49	56.2	85	781	1.76	57.7	87	
125	10.79	517	0.99	35.3	82	595	1.23	44.8	83	663	1.49	50.6	83	732	1.77	54.4	85	797	2.08	56.2	88	
137.5	11.87	553	1.26	33.2	85	626	1.53	41.8	85	691	1.81	47.8	86	754	2.11	51.9	86	814	2.40	54.7	88	
150	12.95	590	1.58	31.3	87	660	1.89	39.1	87	721	2.18	45.2	88	777	2.46	49.7	88	835	2.81	52.5	89	
162.5	14.03	627	1.95	29.7	89	693	2.29	37.1	89	751	2.58	43.0	89	806	2.92	47.2	90	859	3.26	50.4	90	
175	15.11	665	2.37	28.7	90	725	2.71	35.5	90	784	3.08	40.6	91	837	3.44	44.8	91	885	3.76	48.4	92	
187.5	16.19	706	2.90	27.4	92	760	3.22	34.0	92	817	3.63	38.7	93	866	3.96	43.0	93	914	4.34	46.4	93	
200	17.27	745	3.44	26.8	94	796	3.79	32.7	94	850	4.22	37.1	94	900	4.64	40.9	94	945	5.01	44.3	95	
212.5	18.35	785	4.09	25.7	95	835	4.48	31.3	95	885	4.90	35.7	95	933	5.35	39.1	96	976	5.72	42.5	96	

Air flow (m³/min)	Outlet Vel (m/sec)	60 mmAq (588 Pa)				70 mmAq (686 Pa)				80 mmAq (785 Pa)				90 mmAq (883 Pa)				100 mmAq (981 Pa)				
		rpm	BkW	η _t	PWL	rpm	BkW	η _t	PWL	rpm	BkW	η _t	PWL	rpm	BkW	η _t	PWL	rpm	BkW	η _t	PWL	
75	6.48																					
87.5	7.55																					
100	8.63																					
112.5	9.71																					
125	10.79	858	2.38	57.4	90	916	2.68	58.2	93													
137.5	11.87	873	2.73	56.2	90	930	3.09	57.1	93	984	3.44	57.9	95									
150	12.95	891	3.13	54.9	91	945	3.49	56.1	93	997	3.86	57.0	95	1048	4.24	57.7	96	1096	4.64	58.1	97	
162.5	14.03	912	3.61	52.9	91	962	3.94	54.8	93	1013	4.35	55.9	95	1061	4.74	56.8	96	1109	5.17	57.3	97	
175	15.11	935	4.15	50.8	92	983	4.49	53.2	93	1031	4.91	54.6	95	1078	5.31	55.8	96	1124	5.76	56.4	97	
187.5	16.19	960	4.74	49.0	94	1006	5.12	51.2	94	1052	5.54	53.0	95	1097	5.96	54.4	96	1140	6.39	55.4	97	
200	17.27	988	5.40	47.1	95	1031	5.79	49.5	95	1074	6.23	51.2	95	1118	6.69	52.8	96	1160	7.11	54.2	97	
212.5	18.35	1020	6.18	45.2	96	1060	6.60	47.5	97	1100	7.01	49.6	97	1140	7.45	51.2	97	1181	7.92	52.7	98	

- Power rating BkW does not include transmission losses.
 - The A-weighted sound ratings shown have been calculated per AMCA International Standard 301. Values shown are for inlet LwiA sound power levels for installation type B (free inlet, ducted outlet).
 - Performance certified is for installation type B: free inlet, ducted outlet. Performance ratings do not include the effects of appurtenance (accessories).
 GSF-SS Version 11.0_May2024

SIROCCO FAN
GSF-SS series

GSF-SS series

SIROCCO FAN

www.gsfan.co.kr



GSF-3.5SS

FEG 60

Wheel dia	525 mm	Tip Speed = 0.02749 * rpm	Outlet Dim'	420 * 535	Outlet Area	0.2247 m ²	Class 1	909 rpm	Class 2	1146 rpm	Not Applicable
-----------	--------	---------------------------	-------------	-----------	-------------	-----------------------	---------	---------	---------	----------	----------------

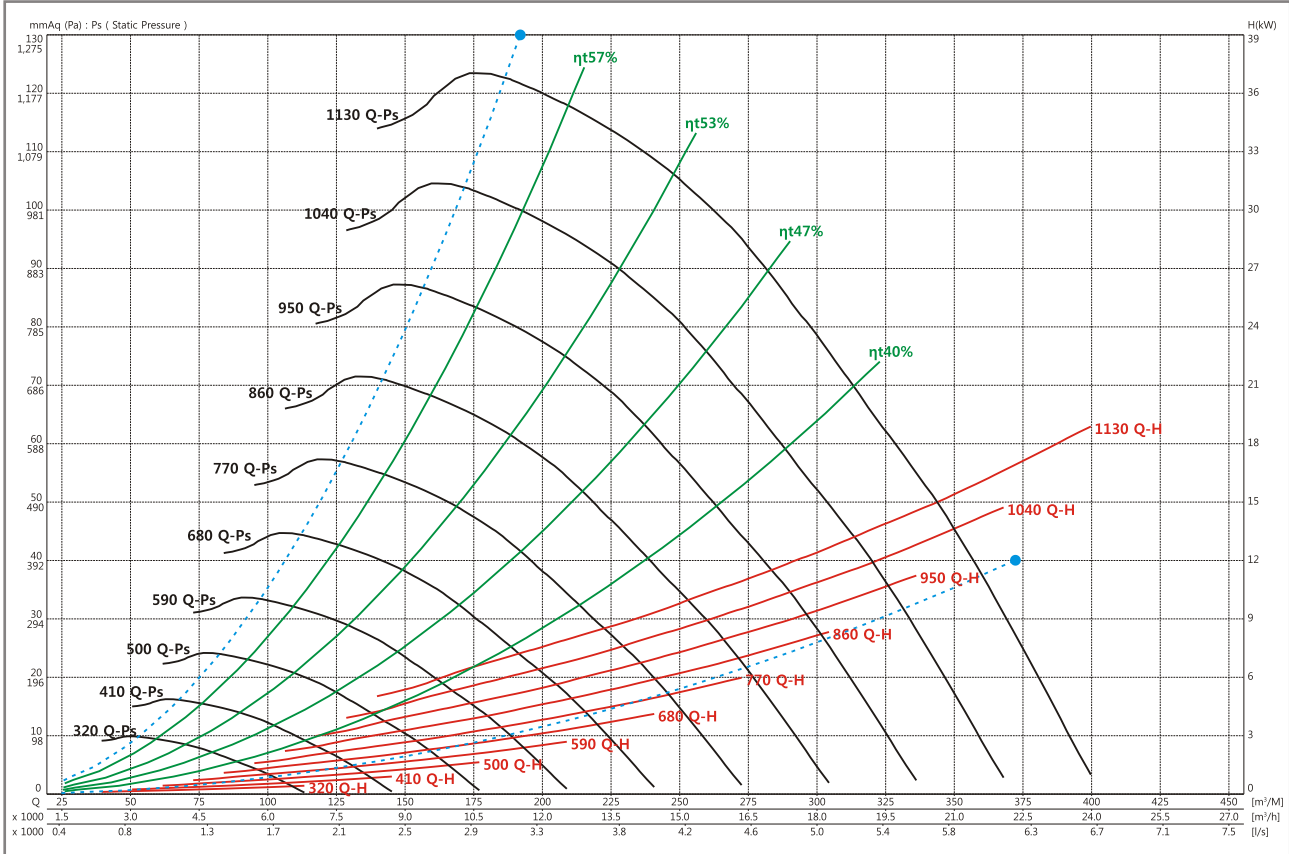

Air flow (m³/min)	Outlet Vel (m/sec)	10 mmAq (98 Pa)				20 mmAq (196 Pa)				30 mmAq (294 Pa)				40 mmAq (392 Pa)				50 mmAq (490 Pa)			
		rpm	BkW	ηt	PWL	rpm	BkW	ηt	PWL	rpm	BkW	ηt	PWL	rpm	BkW	ηt	PWL	rpm	BkW	ηt	PWL
85	6.30	361	0.35	49.7	71	465	0.55	57.1	79												
100	7.42	389	0.48	45.2	74	481	0.70	54.6	79	565	0.94	57.7	83								
115	8.53	421	0.67	40.9	77	502	0.90	50.9	78	580	1.17	55.8	83	652	1.45	57.7	85				
130	9.64	453	0.89	37.5	80	528	1.15	47.5	81	599	1.43	53.3	83	667	1.73	56.1	85	730	2.05	57.5	87
145	10.76	486	1.16	35.0	83	558	1.45	44.3	84	621	1.74	50.4	84	684	2.05	54.2	86	745	2.41	56.1	88
160	11.87	520	1.49	32.7	85	588	1.80	41.4	86	648	2.13	47.5	86	706	2.47	51.5	87	762	2.82	54.4	88
175	12.98	556	1.88	30.8	87	621	2.25	38.7	88	677	2.58	44.7	88	731	2.94	49.2	89	783	3.31	52.1	89
190	14.09	594	2.35	29.5	89	653	2.72	36.8	90	709	3.11	42.2	90	759	3.49	46.7	91	807	3.87	49.9	91
205	15.21	632	2.88	28.4	91	687	3.29	35.0	91	740	3.69	40.2	92	789	4.11	44.3	92	833	4.49	47.8	93
220	16.32	670	3.52	27.0	93	721	3.92	33.4	93	773	4.39	38.0	93	820	4.82	42.2	94	863	5.25	45.5	94
235	17.43	710	4.23	26.4	94	756	4.64	32.0	95	806	5.14	36.5	95	850	5.58	40.3	95	893	6.04	43.7	96
250	18.54	749	5.02	25.7	96	794	5.49	30.8	96	839	5.98	35.1	96	883	6.49	38.5	97	924	6.96	41.8	97

Air flow (m³/min)	Outlet Vel (m/sec)	60 mmAq (588 Pa)				70 mmAq (686 Pa)				80 mmAq (785 Pa)				90 mmAq (883 Pa)				100 mmAq (981 Pa)			
		rpm	BkW	ηt	PWL	rpm	BkW	ηt	PWL	rpm	BkW	ηt	PWL	rpm	BkW	ηt	PWL	rpm	BkW	ηt	PWL
85	6.30																				
100	7.42																				
115	8.53																				
130	9.64	789	2.39	58.3	90																
145	10.76	802	2.77	57.2	90	857	3.14	58.1	92												
160	11.87	817	3.20	56.1	90	870	3.61	57.0	93	920	4.01	57.8	95	968	4.42	58.3	97				
175	12.98	835	3.68	54.6	91	885	4.11	55.9	93	934	4.57	56.8	95	980	4.99	57.4	97	1025	5.44	58.0	98
190	14.09	855	4.27	52.4	92	903	4.69	54.4	93	949	5.13	55.7	95	995	5.63	56.4	97	1038	6.11	57.1	98
205	15.21	878	4.92	50.4	93	923	5.36	52.5	94	968	5.83	54.2	95	1011	6.30	55.4	97	1053	6.80	56.2	98
220	16.32	905	5.68	48.4	94	946	6.14	50.5	95	989	6.62	52.4	96	1030	7.10	53.9	97	1070	7.59	55.1	98
235	17.43	933	6.52	46.4	96	973	7.01	48.7	96	1011	7.50	50.5	96	1051	8.01	52.1	97	1089	8.48	53.7	98
250	18.54	964	7.48	44.4	97	1001	7.98	46.8	98	1036	8.44	48.9	98	1074	9.02	50.4	98	1111	9.53	51.9	98

- Power rating BkW does not include transmission losses.
 - The A-weighted sound ratings shown have been calculated per AMCA International Standard 301. Values shown are for inlet LwiA sound power levels for installation type B (free inlet, ducted outlet).
 - Performance certified is for installation type B: free inlet, ducted outlet. Performance ratings do not include the effects of appurtenance (accessories).
 GSF-SS Version 11.0_May,2024

GSF-SS series

SIROCCO FAN
www.gsfan.co.kr



GSF-3.75SS

FEG 60

Wheel dia	565 mm	Tip Speed = 0.02958 * rpm	Outlet Dim'	450 * 570	Outlet Area	0.2565 m ²	Class 1	845 rpm	Class 2	1065 rpm	Not Applicable
-----------	--------	---------------------------	-------------	-----------	-------------	-----------------------	---------	---------	---------	----------	----------------

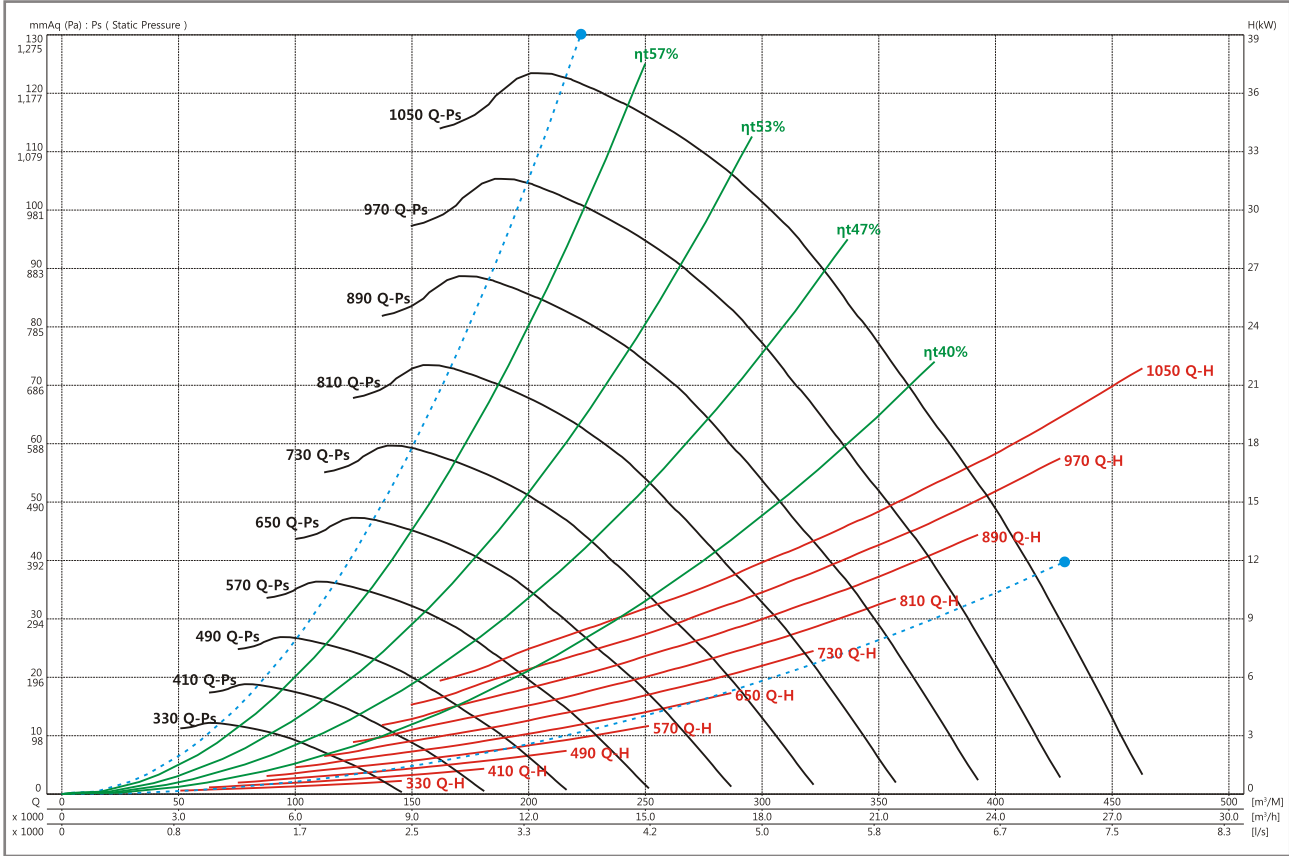

Air flow (m³/min)	Outlet Vel (m/sec)	10 mmAq (98 Pa)				20 mmAq (196 Pa)				30 mmAq (294 Pa)				40 mmAq (392 Pa)				50 mmAq (490 Pa)				
		rpm	BkW	η _t	PWL	rpm	BkW	η _t	PWL	rpm	BkW	η _t	PWL	rpm	BkW	η _t	PWL	rpm	BkW	η _t	PWL	
115	7.47	361	0.56	45.2	74	446	0.80	55.0	78	525	1.09	57.7	85									
130	8.45	385	0.73	41.8	77	463	1.00	51.7	79	536	1.30	56.1	84	604	1.63	57.9	86					
145	9.42	410	0.94	38.5	80	483	1.24	48.7	81	551	1.55	54.2	84	615	1.90	56.6	86	675	2.26	57.9	88	
160	10.40	437	1.20	35.9	82	505	1.51	45.6	83	568	1.86	51.5	84	628	2.20	55.2	86	686	2.60	56.8	88	
175	11.37	464	1.49	34.0	84	530	1.85	43.0	85	587	2.18	49.4	85	643	2.56	53.2	87	698	2.96	55.6	89	
190	12.35	493	1.85	32.2	86	555	2.23	40.6	87	610	2.60	46.8	87	662	3.00	50.8	88	714	3.42	53.9	89	
205	13.32	522	2.25	30.8	88	581	2.67	38.5	88	634	3.08	44.3	89	682	3.47	48.9	89	731	3.93	51.7	90	
220	14.29	552	2.73	29.5	90	607	3.15	36.8	90	658	3.59	42.2	90	705	4.03	46.7	91	750	4.49	49.9	91	
235	15.27	581	3.23	28.4	91	633	3.69	35.3	92	684	4.19	40.3	92	729	4.64	44.7	92	771	5.12	48.0	93	
250	16.24	613	3.86	27.4	93	661	4.31	34.0	93	710	4.85	38.7	93	753	5.34	42.7	94	794	5.83	46.1	94	
265	17.22	644	4.53	26.8	94	689	5.01	32.7	94	736	5.59	37.1	95	779	6.11	41.0	95	819	6.64	44.3	95	
280	18.19	675	5.30	25.7	96	718	5.79	31.5	96	762	6.35	35.9	96	804	6.95	39.4	96	843	7.49	42.7	97	

Air flow (m³/min)	Outlet Vel (m/sec)	60 mmAq (588 Pa)				70 mmAq (686 Pa)				80 mmAq (785 Pa)				90 mmAq (883 Pa)				100 mmAq (981 Pa)				
		rpm	BkW	η _t	PWL	rpm	BkW	η _t	PWL	rpm	BkW	η _t	PWL	rpm	BkW	η _t	PWL	rpm	BkW	η _t	PWL	
115	7.47																					
130	8.45																					
145	9.42																					
160	10.40	740	3.00	57.9	90																	
175	11.37	751	3.41	56.8	90	801	3.85	57.8	92	848	4.29	58.3	94									
190	12.35	764	3.85	55.8	91	812	4.33	56.8	92	858	4.80	57.6	94	903	5.31	58.1	96					
205	13.32	778	4.35	54.3	91	824	4.83	55.8	93	869	5.36	56.6	95	913	5.88	57.3	97	954	6.40	57.9	99	
220	14.29	795	4.94	52.5	92	839	5.43	54.4	93	882	5.94	55.7	95	924	6.51	56.4	97	965	7.05	57.1	99	
235	15.27	813	5.60	50.6	93	855	6.10	52.8	94	897	6.61	54.5	95	937	7.16	55.6	97	977	7.78	56.3	99	
250	16.24	833	6.31	49.0	94	874	6.89	50.9	95	913	7.39	52.9	96	952	7.94	54.4	97	990	8.54	55.4	99	
265	17.22	856	7.13	47.2	96	893	7.67	49.5	96	931	8.24	51.3	96	968	8.82	52.9	97	1004	9.36	54.3	98	
280	18.19	880	8.04	45.5	97	915	8.60	47.8	97	950	9.15	49.8	97	986	9.80	51.3	98	1021	10.30	52.9	99	

- Power rating BkW does not include transmission losses.
 - The A-weighted sound ratings shown have been calculated per AMCA International Standard 301. Values shown are for inlet LwiA sound power levels for installation type B (free inlet, ducted outlet).
 - Performance certified is for installation type B: free inlet, ducted outlet. Performance ratings do not include the effects of appurtenance (accessories).
 GSF-SS Version 11.0_May2024

SIROCCO FAN
GSF-SS series

GSF-SS series

SIROCCO FAN

www.gsfan.co.kr



GSF-4SS

FEG 63

Wheel dia	600 mm	Tip Speed = 0.03142 * rpm	Outlet Dim'	480 * 610	Outlet Area	0.2928 m ²	Class 1	769 rpm	Class 2	1003 rpm	Not Applicable
-----------	--------	---------------------------	-------------	-----------	-------------	-----------------------	---------	---------	---------	----------	----------------

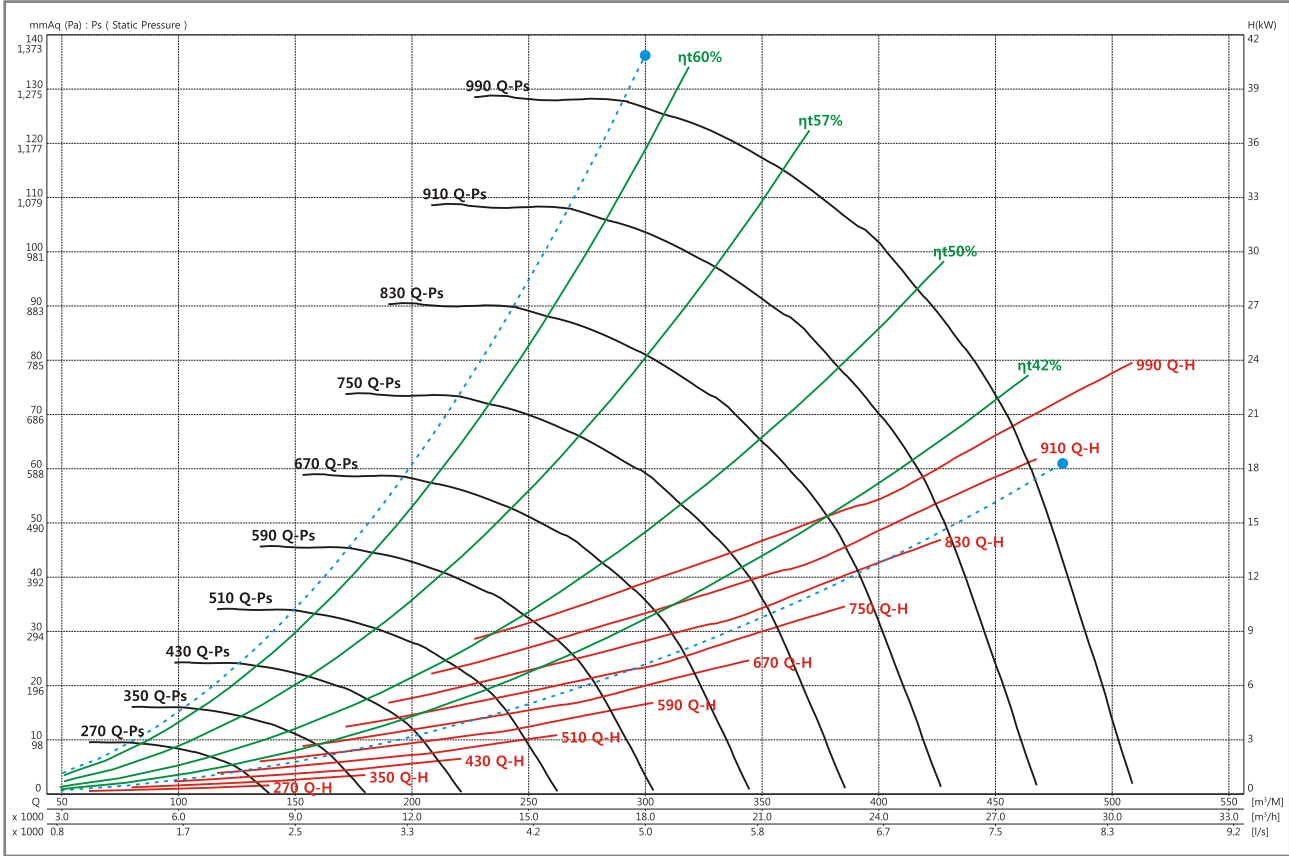

Air flow (m ³ /min)	Outlet Vel (m/sec)	10 mmAq (98 Pa)				20 mmAq (196 Pa)				30 mmAq (294 Pa)				40 mmAq (392 Pa)				50 mmAq (490 Pa)				
		rpm	BkW	η _t	PWL	rpm	BkW	η _t	PWL	rpm	BkW	η _t	PWL	rpm	BkW	η _t	PWL	rpm	BkW	η _t	PWL	
120	6.83	305	0.46	54.0	70	394	0.75	60.2	72													
137.5	7.83	327	0.63	49.5	73	404	0.91	58.7	74													
155	8.82	349	0.84	44.5	77	418	1.12	56.2	77	486	1.47	59.7	78									
172.5	9.82	375	1.10	40.8	80	434	1.35	53.9	79	498	1.74	58.2	80	559	2.15	60.1	82					
190	10.82	405	1.43	37.3	82	456	1.68	50.3	81	512	2.05	56.2	82	568	2.47	59.1	83	623	2.94	60.2	85	
207.5	11.81	435	1.81	34.7	85	478	2.07	46.7	84	529	2.42	54.1	84	581	2.87	57.3	85	632	3.34	59.4	86	
225	12.81	467	2.28	32.4	87	502	2.52	43.7	86	548	2.84	51.9	85	596	3.31	55.4	86	644	3.80	58.0	87	
242.5	13.80	499	2.82	30.4	89	529	3.08	40.8	88	570	3.38	48.8	88	613	3.79	54.0	88	658	4.34	56.3	89	
260	14.80	531	3.43	29.3	91	558	3.71	38.4	90	594	4.04	45.8	90	633	4.37	51.9	89	675	4.92	54.7	90	
277.5	15.80	564	4.15	28.1	93	588	4.41	36.5	92	618	4.72	43.6	92	655	5.09	49.2	91	692	5.53	53.6	91	
295	16.79	596	4.93	27.0	94	618	5.20	34.7	94	644	5.54	41.0	93	678	5.92	46.7	93	713	6.30	51.5	93	
312.5	17.79	628	5.82	25.6	96	650	6.12	33.1	95	673	6.46	39.1	95	702	6.83	44.5	95	735	7.23	49.0	94	

Air flow (m ³ /min)	Outlet Vel (m/sec)	60 mmAq (588 Pa)				70 mmAq (686 Pa)				80 mmAq (785 Pa)				90 mmAq (883 Pa)				100 mmAq (981 Pa)				
		rpm	BkW	η _t	PWL	rpm	BkW	η _t	PWL	rpm	BkW	η _t	PWL	rpm	BkW	η _t	PWL	rpm	BkW	η _t	PWL	
120	6.83																					
137.5	7.83																					
155	8.82																					
172.5	9.82																					
190	10.82																					
207.5	11.81	682	3.84	60.3	87																	
225	12.81	691	4.32	59.5	88	738	4.89	60.2	89													
242.5	13.80	703	4.88	58.3	90	746	5.44	59.5	90	789	6.01	60.2	91	827	6.57	60.8	91					
260	14.80	716	5.47	56.9	91	757	6.03	58.5	91	798	6.66	59.5	92	838	7.28	60.0	92	877	7.94	60.6	93	
277.5	15.80	732	6.16	55.3	92	770	6.73	57.2	92	809	7.37	58.5	93	847	8.01	59.5	93	885	8.70	59.9	94	
295	16.79	749	6.88	54.0	93	786	7.54	55.7	93	822	8.17	57.3	94	859	8.82	58.5	94	894	9.51	59.3	95	
312.5	17.79	767	7.66	52.7	94	803	8.38	54.4	94	837	9.04	55.9	95	872	9.72	57.3	95	906	10.40	58.4	96	

- Power rating BkW does not include transmission losses.
 - The A-weighted sound ratings shown have been calculated per AMCA International Standard 301. Values shown are for inlet LwiA sound power levels for installation type B (free inlet, ducted outlet).
 - Performance certified is for installation type B: free inlet, ducted outlet. Performance ratings do not include the effects of appurtenance (accessories).

GSF-SS series

SIROCCO FAN

www.gsfan.co.kr



GSF-4.25SS

FEG 63

Wheel dia	640 mm	Tip Speed = 0.03351 * rpm	Outlet Dim	510 * 650	Outlet Area	0.3315 m ²	Class 1	746 rpm	Class 2	940 rpm	Not Applicable
-----------	--------	---------------------------	------------	-----------	-------------	-----------------------	---------	---------	---------	---------	----------------

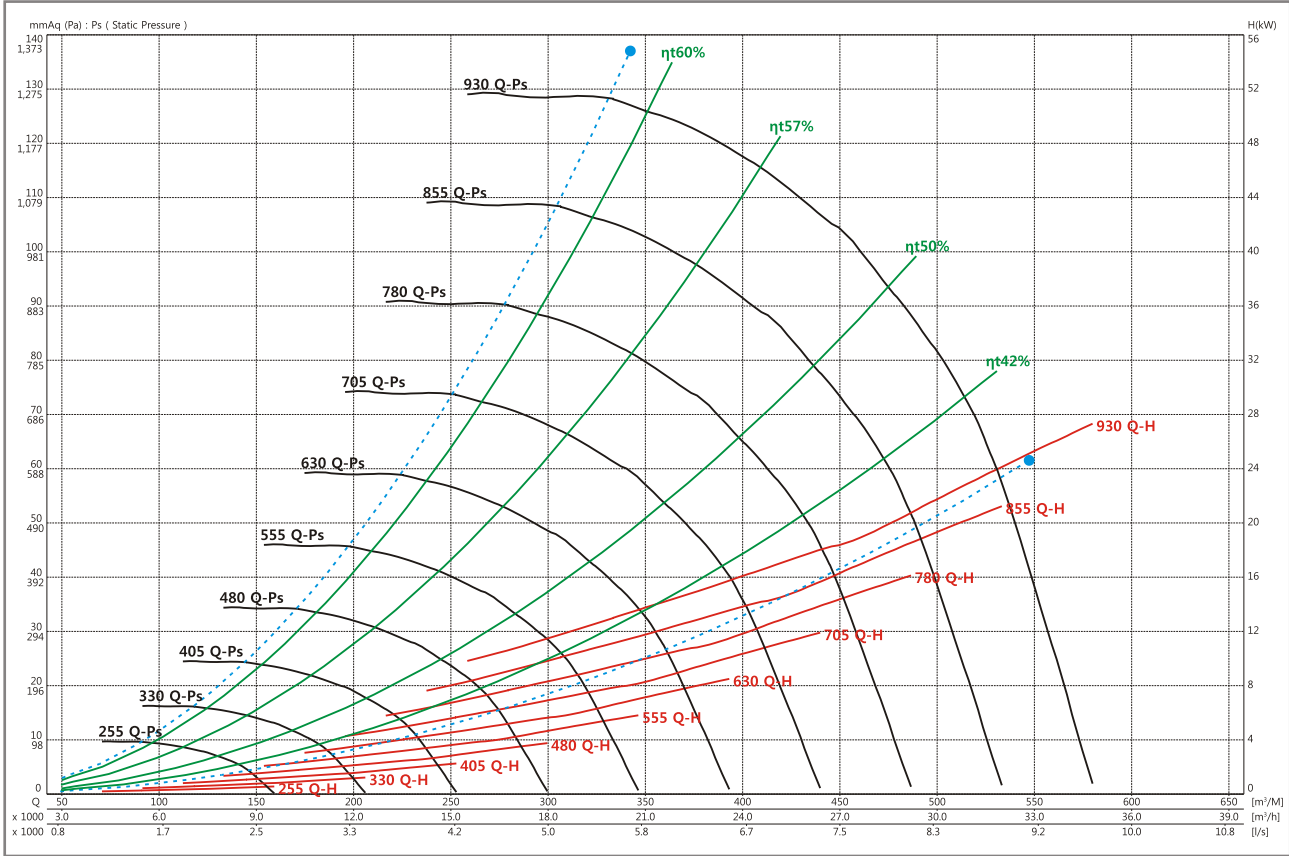

Air flow (m³/min)	Outlet Vel (m/sec)	10 mmAq (98 Pa)				20 mmAq (196 Pa)				30 mmAq (294 Pa)				40 mmAq (392 Pa)				50 mmAq (490 Pa)				
		rpm	BkW	η _t	PWL	rpm	BkW	η _t	PWL	rpm	BkW	η _t	PWL	rpm	BkW	η _t	PWL	rpm	BkW	η _t	PWL	
130	6.54	281	0.49	55.0	69	366	0.79	60.7	72													
150	7.54	299	0.64	51.5	72	375	0.97	59.3	74													
170	8.55	320	0.87	45.7	76	387	1.19	56.9	76	454	1.59	60.1	78									
190	9.55	344	1.16	41.7	79	402	1.46	54.3	79	463	1.87	58.8	80	521	2.33	60.5	81					
210	10.56	371	1.51	38.1	82	421	1.78	51.7	81	475	2.21	56.8	82	529	2.68	59.5	83	582	3.21	60.6	84	
230	11.56	399	1.92	35.5	84	441	2.21	47.7	83	491	2.62	54.6	84	541	3.12	57.9	85	589	3.64	59.7	86	
250	12.57	429	2.43	33.1	87	464	2.72	44.5	86	508	3.06	52.9	85	554	3.61	56.0	86	600	4.16	58.4	87	
270	13.57	459	3.01	31.6	89	489	3.31	41.8	88	529	3.67	49.6	87	570	4.15	54.3	88	613	4.74	56.9	88	
290	14.58	489	3.70	29.3	91	515	4.00	39.1	90	549	4.34	46.7	89	587	4.74	52.7	89	628	5.39	55.2	90	
310	15.59	519	4.46	28.1	92	542	4.75	37.0	92	572	5.13	44.1	91	608	5.54	49.9	91	643	6.06	53.9	91	
330	16.59	550	5.35	27.0	94	571	5.66	34.7	94	597	6.04	41.7	93	629	6.46	47.2	93	662	6.91	51.9	92	
350	17.60	580	6.32	25.9	96	601	6.68	33.1	95	623	7.02	39.8	95	651	7.46	45.0	94	683	7.93	49.5	94	

Air flow (m³/min)	Outlet Vel (m/sec)	60 mmAq (588 Pa)				70 mmAq (686 Pa)				80 mmAq (785 Pa)				90 mmAq (883 Pa)				100 mmAq (981 Pa)				
		rpm	BkW	η _t	PWL	rpm	BkW	η _t	PWL	rpm	BkW	η _t	PWL	rpm	BkW	η _t	PWL	rpm	BkW	η _t	PWL	
130	6.54																					
150	7.54																					
170	8.55																					
190	9.55																					
210	10.56																					
230	11.56	637	4.21	60.6	87																	
250	12.57	645	4.75	59.8	88	689	5.38	60.5	89													
270	13.57	655	5.33	58.7	89	697	5.97	59.8	90	737	6.65	60.4	91									
290	14.58	667	6.00	57.3	91	707	6.68	58.8	91	745	7.34	59.7	92	784	8.07	60.3	92					
310	15.59	682	6.78	55.8	92	719	7.47	57.5	93	755	8.14	58.8	93	791	8.85	59.7	93	828	9.65	60.1	94	
330	16.59	698	7.63	54.3	93	732	8.30	56.1	94	767	9.04	57.5	94	802	9.76	58.8	94	836	10.5	59.6	95	
350	17.60	714	8.43	53.3	94	748	9.25	54.7	95	781	10.0	56.3	95	814	10.8	57.6	95	846	11.5	58.7	96	

- Power rating BkW does not include transmission losses.
 - The A-weighted sound ratings shown have been calculated per AMCA International Standard 301. Values shown are for inlet LwiA sound power levels for installation type B (free inlet, ducted outlet).
 - Performance certified is for installation type B: free inlet, ducted outlet. Performance ratings do not include the effects of appurtenance (accessories).

GSF-SS series

SIROCCO FAN
www.gsfan.co.kr



GSF-4.5SS

FEG 56

Wheel dia	675 mm	Tip Speed =	0.035343 * rpm	Outlet Dim'	540 * 685	Outlet Area	0.3699 m ²	Class 1	707 rpm	Class 2	891 rpm	Not Applicable
-----------	--------	-------------	----------------	-------------	-----------	-------------	-----------------------	---------	---------	---------	---------	----------------

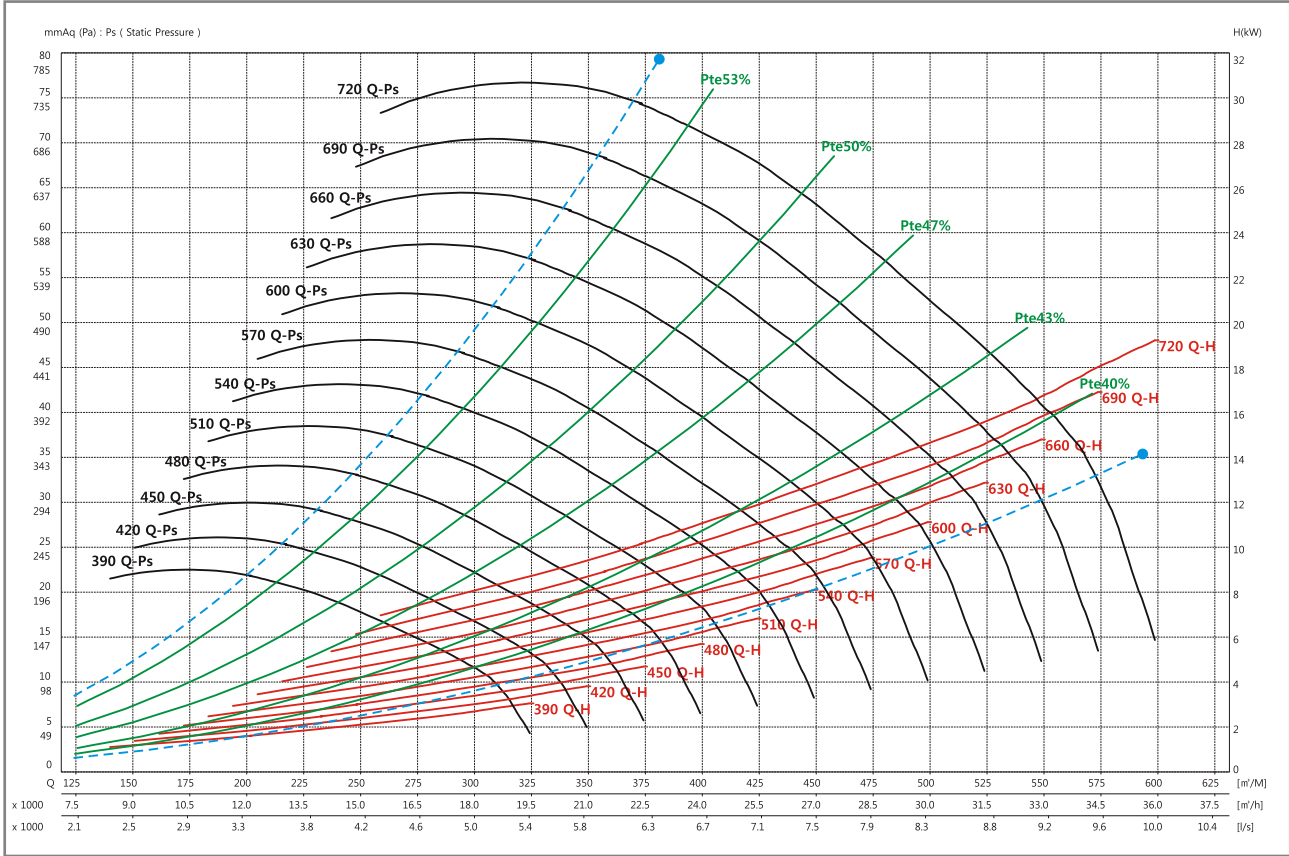

Air flow (m³/min)	Outlet Vel (m/sec)	20 mmAq (196 Pa)				25 mmAq (245 Pa)				30 mmAq (294 Pa)				35 mmAq (343 Pa)				40 mmAq (392 Pa)			
		rpm	BkW	η _t	PWL	rpm	BkW	η _t	PWL	rpm	BkW	η _t	PWL	rpm	BkW	η _t	PWL	rpm	BkW	η _t	PWL
		m ⁻¹	kW	%	LwIA	m ⁻¹	kW	%	LwIA	m ⁻¹	kW	%	LwIA	m ⁻¹	kW	%	LwIA	m ⁻¹	kW	%	LwIA
250	11.26	403	2.231	49.9	86	433	2.533	52.0	87	463	2.845	53.4	88	487	3.118	54.3	89				
275	12.39	420	2.702	47.8	87	447	3.021	50.2	88	474	3.333	52.0	89	502	3.701	53.1	90	528	4.047	54.1	90
300	13.52	438	3.247	45.9	88	464	3.597	48.3	89	490	3.951	50.2	90	514	4.283	51.9	90	539	4.664	52.8	91
325	14.64	457	3.872	44.2	90	482	4.237	46.6	90	506	4.625	48.5	91	529	4.981	50.2	92	552	5.37	51.6	92
350	15.77	475	4.573	42.7	91	500	4.968	45.0	92	524	5.375	47.0	92	546	5.776	48.6	93	568	6.191	50.1	93
375	16.90	496	5.382	41.2	92	519	5.784	43.7	93	542	6.217	45.5	93	563	6.637	47.2	94	584	7.09	48.6	94
400	18.02	517	6.35	39.6	94	539	6.735	42.2	94	560	7.169	44.2	95	582	7.636	45.7	95	602	8.105	47.2	95
425	19.15	540	7.448	38.1	95	559	7.815	40.8	95	580	8.235	42.9	96	600	8.697	44.5	96	620	9.228	45.8	96
450	20.28	565	8.726	36.7	100	580	9.011	39.5	96	599	9.412	41.7	97	619	9.877	43.4	97	638	10.421	44.7	98
475	21.40	591	10.11	35.3	104	603	10.403	38.1	98	620	10.759	40.4	98	639	11.228	42.2	98	657	11.733	43.7	99
500	22.53	617	11.627	34.3	108	628	11.976	36.8	102	642	12.316	39.1	99	659	12.74	41.0	99	677	13.23	42.5	100
525	23.66	645	13.374	33.3	110	654	13.679	35.7	106	665	13.952	38.0	101	680	14.393	39.8	100	697	14.865	41.4	101

Air flow (m³/min)	Outlet Vel (m/sec)	45 mmAq (441 Pa)				50 mmAq (490 Pa)				55 mmAq (539 Pa)				60 mmAq (588 Pa)				65 mmAq (637 Pa)				
		rpm	BkW	η _t	PWL	rpm	BkW	η _t	PWL	rpm	BkW	η _t	PWL	rpm	BkW	η _t	PWL	rpm	BkW	η _t	PWL	
		m ⁻¹	kW	%	LwIA	m ⁻¹	kW	%	LwIA	m ⁻¹	kW	%	LwIA	m ⁻¹	kW	%	LwIA	m ⁻¹	kW	%	LwIA	
250	11.26																					
275	12.39																					
300	13.52	564	5.053	53.7	92	584	5.374	54.4	93													
325	14.64	576	5.775	52.5	93	599	6.191	53.3	94	621	6.592	54.0	94									
350	15.77	589	6.588	51.3	94	610	7.008	52.2	94	632	7.474	52.9	95	653	7.919	53.6	96	674	8.367	54.1	96	
375	16.90	604	7.531	49.9	95	624	7.954	51.0	95	644	8.412	51.9	96	665	8.893	52.5	96	685	9.369	53.1	97	
400	18.02	621	8.577	48.4	96	640	9.023	49.6	96	659	9.476	50.6	97	677	9.936	51.5	97	697	10.455	52.2	98	
425	19.15	638	9.671	47.2	97	657	10.176	48.3	97	675	10.65	49.4	98	693	11.188	50.2	98	710	11.653	51.1	98	
450	20.28	657	10.952	45.9	98	674	11.436	47.1	98	692	11.973	48.1	99	709	12.511	49.0	99					
475	21.40	675	12.322	44.8	99	693	12.843	45.9	99	709	13.365	47.0	100									
500	22.53	694	13.752	43.8	100	711	14.341	44.8	100													
525	23.66	713	15.433	42.7	101																	

- Power rating BkW does not include transmission losses.
 - The A-weighted sound ratings shown have been calculated per AMCA International Standard 301. Values shown are for inlet LwIA sound power levels for installation type B (free inlet, ducted outlet).
 - Performance certified is for installation type B: free inlet, ducted outlet. Performance ratings do not include the effects of appurtenance (accessories).
 GSF-SS Version 11.0_May,2024

GSF-SS series

SIROCCO FAN

www.gsfan.co.kr



GSF-5SS

FEG 63

Wheel dia	750 mm	Tip Speed = 0.03927 * rpm	Outlet Dim'	600 * 760	Outlet Area	0.4560 m ²	Class 1	637 rpm	Class 2	802 rpm	Not Applicable
-----------	--------	---------------------------	-------------	-----------	-------------	-----------------------	---------	---------	---------	---------	----------------

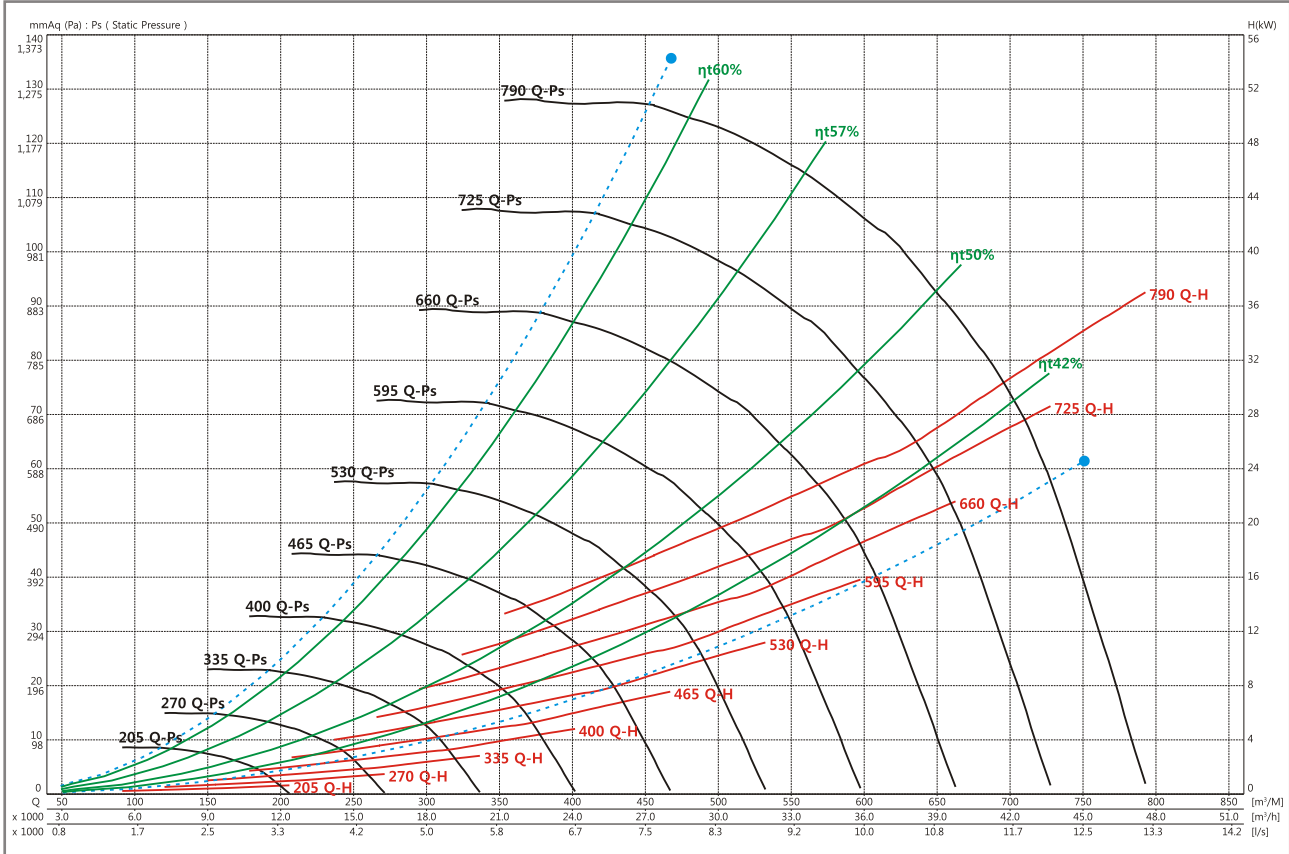

Air flow (m³/min)	Outlet Vel (m/sec)	10 mmAq (98 Pa)				20 mmAq (196 Pa)				30 mmAq (294 Pa)				40 mmAq (392 Pa)				50 mmAq (490 Pa)				
		rpm	BkW	ηt	PWL	rpm	BkW	ηt	PWL	rpm	BkW	ηt	PWL	rpm	BkW	ηt	PWL	rpm	BkW	ηt	PWL	
170	6.21	236	0.61	56.3	68																	
200	7.31	251	0.82	52.5	72	318	1.27	59.7	74													
230	8.41	271	1.15	46.7	76	329	1.59	57.3	77	386	2.13	60.2	78									
260	9.50	293	1.57	42.2	80	343	1.99	54.4	79	395	2.56	58.9	81	445	3.20	60.5	82					
290	10.60	318	2.10	38.1	83	360	2.47	51.5	82	406	3.07	56.7	83	452	3.73	59.4	84	497	4.45	60.5	85	
320	11.70	344	2.74	34.7	86	379	3.12	47.2	85	421	3.69	54.3	85	463	4.39	57.5	85	504	5.11	59.5	86	
350	12.79	372	3.52	32.4	88	401	3.92	43.9	87	437	4.37	52.1	86	476	5.13	55.6	87	515	5.91	58.1	88	
380	13.89	400	4.44	30.4	90	424	4.83	40.8	90	457	5.32	48.8	89	491	5.95	54.0	89	527	6.80	56.3	89	
410	14.99	428	5.51	28.5	92	449	5.90	38.1	92	477	6.43	45.4	91	509	6.97	51.6	90	542	7.83	54.5	91	
440	16.08	457	6.76	27.5	94	476	7.16	36.2	94	499	7.67	42.8	93	528	8.25	48.5	93	557	8.88	53.1	92	
470	17.18	485	8.15	26.3	96	503	8.59	34.1	95	523	9.09	40.7	95	549	9.73	45.8	94	576	10.3	50.3	94	
500	18.27	514	9.75	25.6	98	531	10.2	32.4	97	549	10.8	38.4	97	570	11.3	43.5	96	596	12.0	47.9	96	

Air flow (m³/min)	Outlet Vel (m/sec)	60 mmAq (588 Pa)				70 mmAq (686 Pa)				80 mmAq (785 Pa)				90 mmAq (883 Pa)				100 mmAq (981 Pa)				
		rpm	BkW	ηt	PWL	rpm	BkW	ηt	PWL	rpm	BkW	ηt	PWL	rpm	BkW	ηt	PWL	rpm	BkW	ηt	PWL	
170	6.21																					
200	7.31																					
230	8.41																					
260	9.50																					
290	10.60																					
320	11.70	545	5.90	60.5	87																	
350	12.79	552	6.69	59.6	89	590	7.59	60.3	90													
380	13.89	562	7.62	58.3	90	597	8.50	59.5	91	632	9.47	60.1	92	663	10.3	60.8	93					
410	14.99	574	8.68	56.7	92	607	9.60	58.3	92	639	10.5	59.4	93	672	11.6	59.9	94	702	12.5	60.5	94	
440	16.08	589	9.91	55.0	93	619	10.8	56.9	94	650	11.8	58.2	94	680	12.8	59.3	95	710	13.9	59.8	95	
470	17.18	603	11.1	53.8	94	633	12.2	55.2	95	662	13.2	56.9	95	690	14.2	58.1	96	718	15.3	59.1	96	
500	18.27	621	12.6	51.7	96	648	13.6	54.0	96	676	14.8	55.4	97	702	15.8	56.8	97	729	16.9	57.8	97	

- Power rating BkW does not include transmission losses.
 - The A-weighted sound ratings shown have been calculated per AMCA International Standard 301. Values shown are for inlet LwA sound power levels for installation type B (free inlet, ducted outlet).
 - Performance certified is for installation type B: free inlet, ducted outlet. Performance ratings do not include the effects of appurtenance (accessories).

GSF-SS Version 11.0_May2024

SIROCCO FAN
GSF-SS series

GSF-SS series

SIROCCO FAN

www.gsfan.co.kr



GSF-5.5SS

FEG 63

Wheel dia	825 mm	Tip Speed =	0.0432 * rpm	Outlet Dim'	660 * 840	Outlet Area	0.5544 m ²	Class 1	579 rpm	Class 2	729 rpm	Not Applicable
-----------	--------	-------------	--------------	-------------	-----------	-------------	-----------------------	---------	---------	---------	---------	----------------

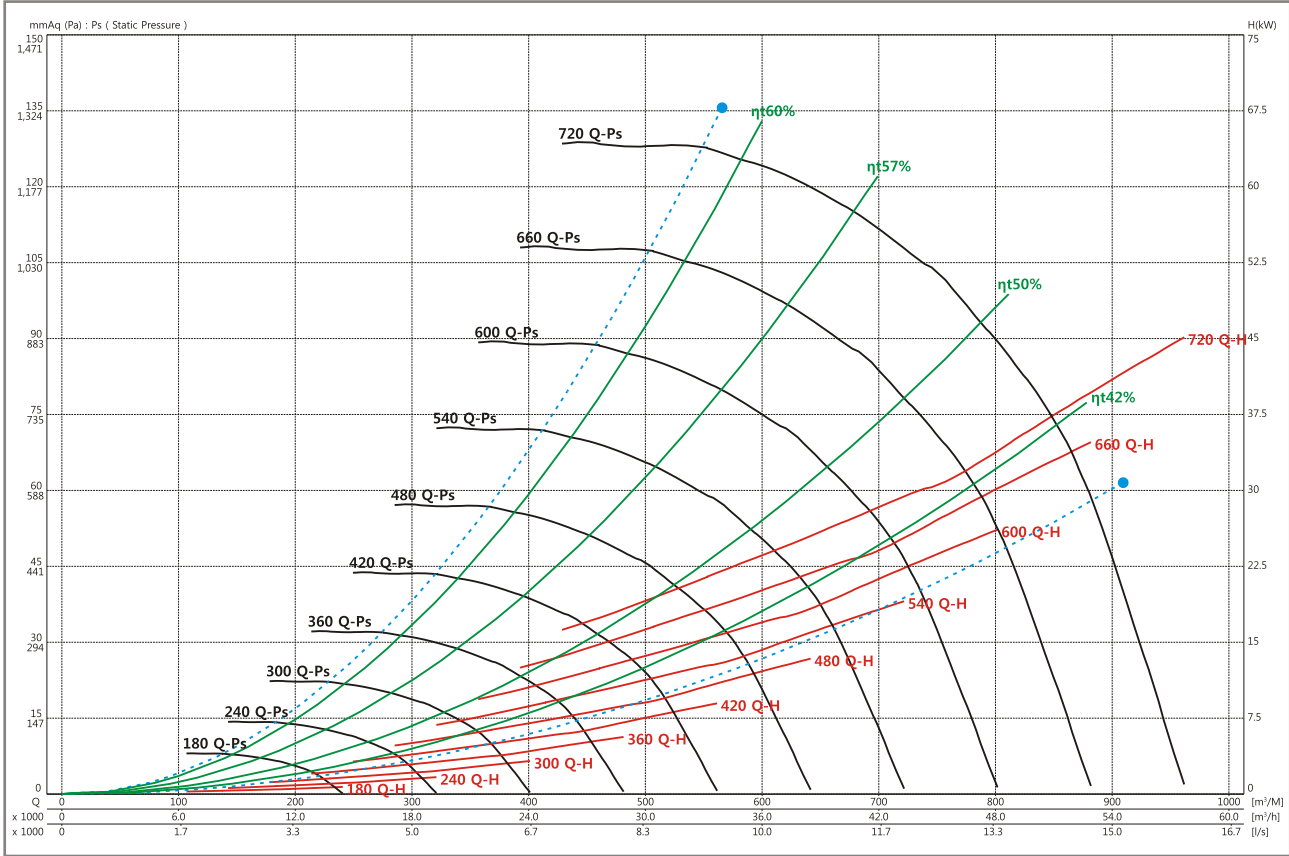

Air flow (m³/min)	Outlet Vel (m/sec)	10 mmAq (98 Pa)				20 mmAq (196 Pa)				30 mmAq (294 Pa)				40 mmAq (392 Pa)				50 mmAq (490 Pa)			
		rpm	BkW	ηt	PWL	rpm	BkW	ηt	PWL	rpm	BkW	ηt	PWL	rpm	BkW	ηt	PWL	rpm	BkW	ηt	PWL
210	6.31	216	0.77	55.8	69																
245	7.37	230	1.03	52.1	72	290	1.57	59.5	75												
280	8.42	247	1.41	46.3	76	300	1.95	57.2	77	351	2.60	60.2	79								
315	9.47	266	1.90	41.7	80	312	2.41	54.4	80	359	3.10	58.9	81	404	3.87	60.5	82				
350	10.52	288	2.51	38.1	83	327	2.97	51.7	82	369	3.71	56.7	83	411	4.50	59.4	84	451	5.34	60.5	85
385	11.57	312	3.27	35.5	86	344	3.73	47.7	85	382	4.41	54.5	85	420	5.24	57.7	86	458	6.13	59.6	87
420	12.63	336	4.17	32.8	88	362	4.63	44.1	87	396	5.20	52.5	87	432	6.13	55.8	87	467	7.04	58.3	88
455	13.68	360	5.21	30.4	91	382	5.68	41.0	90	413	6.29	49.1	89	445	7.09	54.0	89	477	8.05	56.6	90
490	14.73	385	6.43	29.3	92	404	6.91	38.4	92	431	7.55	46.1	91	460	8.21	52.1	91	490	9.25	54.7	91
525	15.78	410	7.84	27.9	94	427	8.33	36.2	94	449	8.95	43.2	93	477	9.66	49.2	93	503	10.4	53.6	92
560	16.84	435	9.44	26.6	96	451	9.96	34.3	95	470	10.6	41.0	95	494	11.3	46.3	94	520	12.1	51.2	94
595	17.89	460	11.2	25.9	98	476	11.8	32.8	97	492	12.4	38.8	97	513	13.2	44.1	96	537	14.0	48.6	96

Air flow (m³/min)	Outlet Vel (m/sec)	60 mmAq (588 Pa)				70 mmAq (686 Pa)				80 mmAq (785 Pa)				90 mmAq (883 Pa)				100 mmAq (981 Pa)			
		rpm	BkW	ηt	PWL	rpm	BkW	ηt	PWL	rpm	BkW	ηt	PWL	rpm	BkW	ηt	PWL	rpm	BkW	ηt	PWL
210	6.31																				
245	7.37																				
280	8.42																				
315	9.47																				
350	10.52																				
385	11.57	495	7.09	60.5	88																
420	12.63	501	8.00	59.7	89	535	9.05	60.4	90												
455	13.68	510	9.08	58.5	90	542	10.2	59.6	91	573	11.3	60.2	92								
490	14.73	520	10.3	57.0	92	550	11.4	58.5	92	580	12.5	59.6	93	610	13.8	60.1	94	637	14.9	60.7	94
525	15.78	532	11.6	55.3	93	560	12.8	57.1	94	589	14.0	58.5	94	616	15.2	59.4	95	644	16.5	59.9	95
560	16.84	545	13.1	54.0	94	572	14.3	55.6	95	599	15.6	57.2	95	625	16.8	58.4	96	651	18.1	59.3	96
595	17.89	560	14.8	52.3	96	585	16.0	54.2	96	610	17.3	55.8	97	635	18.6	57.1	97	660	19.9	58.2	98

- Power rating BkW does not include transmission losses.
 - The A-weighted sound ratings shown have been calculated per AMCA International Standard 301. Values shown are for inlet LwIA sound power levels for installation type B (free inlet, ducted outlet).
 - Performance certified is for installation type B: free inlet, ducted outlet. Performance ratings do not include the effects of appurtenance (accessories).

GSF-SS Version 11.0_May2024

GSF-SS series

SIROCCO FAN

www.gsfan.co.kr



GSF-6SS

FEG 67

Wheel dia	900 mm	Tip Speed = 0.04712 * rpm	Outlet Dim'	730 * 915	Outlet Area	0.6680 m ²	Class 1	531 rpm	Class 2	668 rpm	Not Applicable
-----------	--------	---------------------------	-------------	-----------	-------------	-----------------------	---------	---------	---------	---------	----------------

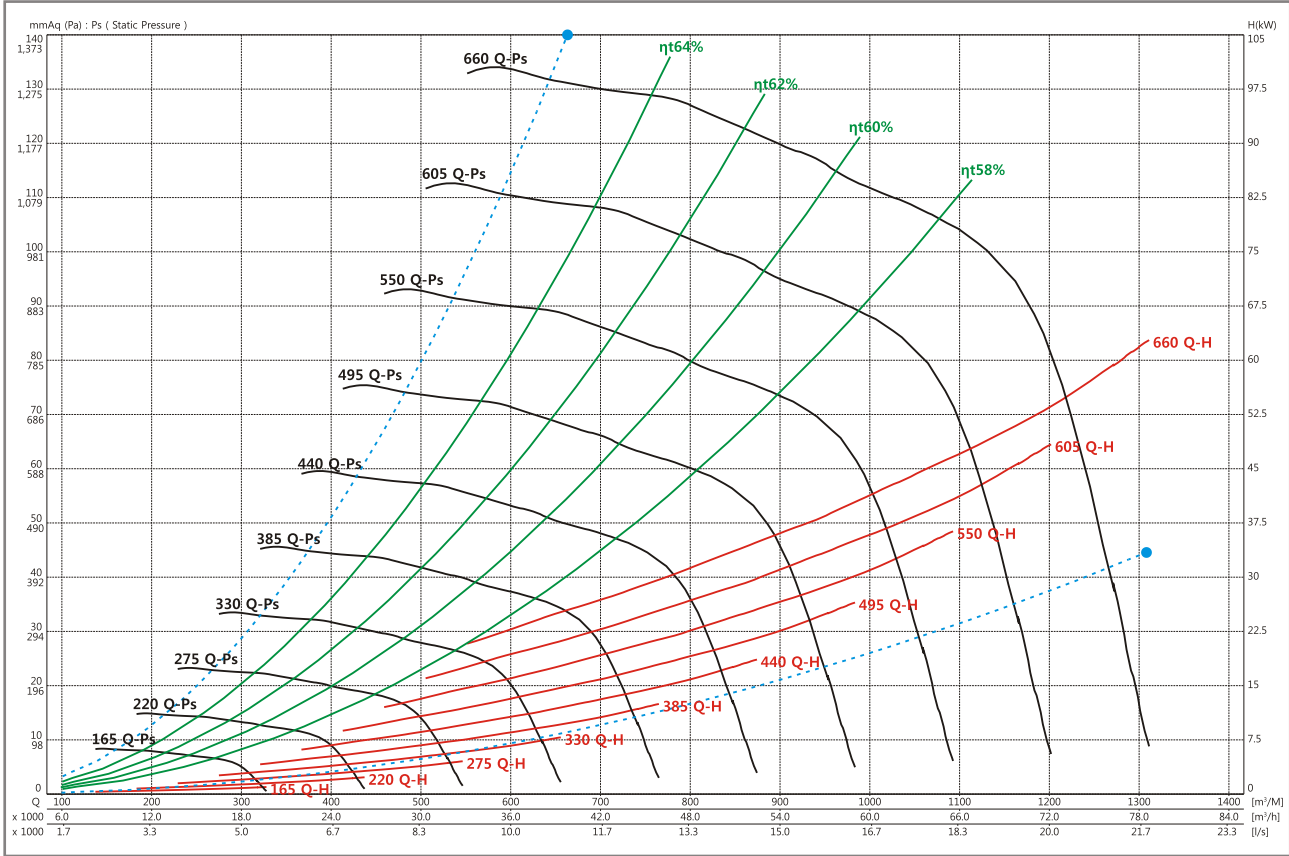

Air flow (m³/min)	Outlet Vel (m/sec)	10 mmAq (98 Pa)				20 mmAq (196 Pa)				30 mmAq (294 Pa)				40 mmAq (392 Pa)				50 mmAq (490 Pa)			
		rpm	BkW	η _t	PWL	rpm	BkW	η _t	PWL	rpm	BkW	η _t	PWL	rpm	BkW	η _t	PWL	rpm	BkW	η _t	PWL
300	7.49	198	1.12	59.1	73	260	1.80	63.6	75												
340	8.48	205	1.40	57.3	75	265	2.17	62.2	77	317	3.01	63.3	79								
380	9.48	216	1.79	54.0	78	272	2.60	61.1	79	320	3.48	63.5	81	366	4.48	63.1	83				
420	10.48	231	2.29	49.7	81	279	3.10	59.2	82	326	4.06	62.2	83	368	5.05	63.5	84	408	6.15	63.1	86
460	11.48	249	2.96	46.2	84	285	3.64	57.9	83	332	4.68	61.1	85	372	5.74	62.8	86	411	6.89	63.4	87
500	12.48	267	3.74	42.5	86	294	4.28	56.3	85	339	5.41	59.6	86	378	6.54	61.7	87	414	7.69	63.2	88
540	13.47	286	4.66	40.5	88	306	5.10	53.7	88	345	6.17	58.6	88	384	7.37	61.0	89	420	8.66	62.2	90
580	14.47	304	5.70	37.5	90	321	6.11	50.5	90	353	7.07	57.5	89	392	8.39	59.6	90	426	9.69	61.3	91
620	15.47	323	6.92	35.6	92	338	7.31	47.7	92	362	8.08	56.0	91	398	9.43	58.7	92	433	10.8	60.7	92
660	16.47	342	8.28	34.4	94	356	8.69	45.4	93	374	9.30	53.8	93	405	10.6	57.7	93	440	12.1	59.3	93
700	17.47	361	9.82	33.0	95	374	10.3	43.0	95	389	10.8	51.3	95	414	11.9	56.6	94	446	13.4	58.6	95
740	18.46	381	11.6	32.1	97	393	12.0	41.5	96	406	12.5	49.2	96	425	13.4	55.0	96	453	14.8	57.7	96

Air flow (m³/min)	Outlet Vel (m/sec)	60 mmAq (588 Pa)				70 mmAq (686 Pa)				80 mmAq (785 Pa)				90 mmAq (883 Pa)				100 mmAq (981 Pa)				
		rpm	BkW	η _t	PWL	rpm	BkW	η _t	PWL	rpm	BkW	η _t	PWL	rpm	BkW	η _t	PWL	rpm	BkW	η _t	PWL	
300	7.49																					
340	8.48																					
380	9.48																					
420	10.48																					
460	11.48	447	8.09	63.1	88																	
500	12.48	450	8.97	63.4	89	483	10.3	63.1	90	513	11.6	62.8	91									
540	13.47	452	9.87	63.4	90	486	11.3	63.4	91	517	12.7	63.2	92	546	14.2	62.8	93					
580	14.47	458	11.0	62.4	92	488	12.3	63.5	92	519	13.9	63.4	93	549	15.4	63.2	94	576	16.9	62.9	95	
620	15.47	465	12.3	61.6	93	494	13.7	62.5	94	522	15.1	63.5	94	551	16.7	63.5	95	579	18.3	63.3	96	
660	16.47	470	13.5	61.0	94	500	15.1	61.8	95	528	16.7	62.6	95	554	18.1	63.5	96	581	19.8	63.5	97	
700	17.47	478	15.0	59.9	95	507	16.6	61.1	96	534	18.2	61.9	96	560	19.8	62.6	97	584	21.4	63.4	98	
740	18.46	485	16.6	59.0	96	513	18.1	60.4	97	540	19.9	61.2	97	566	21.6	62.0	98	590	23.3	62.6	98	

- Power rating BkW does not include transmission losses.
 - The A-weighted sound ratings shown have been calculated per AMCA International Standard 301. Values shown are for inlet LwiA sound power levels for installation type B (free inlet, ducted outlet).
 - Performance certified is for installation type B: free inlet, ducted outlet. Performance ratings do not include the effects of appurtenance (accessories).

GSF-SS Version 11.0_May2024

SIROCCO FAN
GSF-SS series

GSF-SS series

SIROCCO FAN

www.gsfan.co.kr



GSF-6.5SS

FEG 67

Wheel dia	975 mm	Tip Speed = 0.05105 * rpm	Outlet Dim'	790 * 990	Outlet Area	0.7821 m ²	Class 1	490 rpm	Class 2	617 rpm	Not Applicable
-----------	--------	---------------------------	-------------	-----------	-------------	-----------------------	---------	---------	---------	---------	----------------

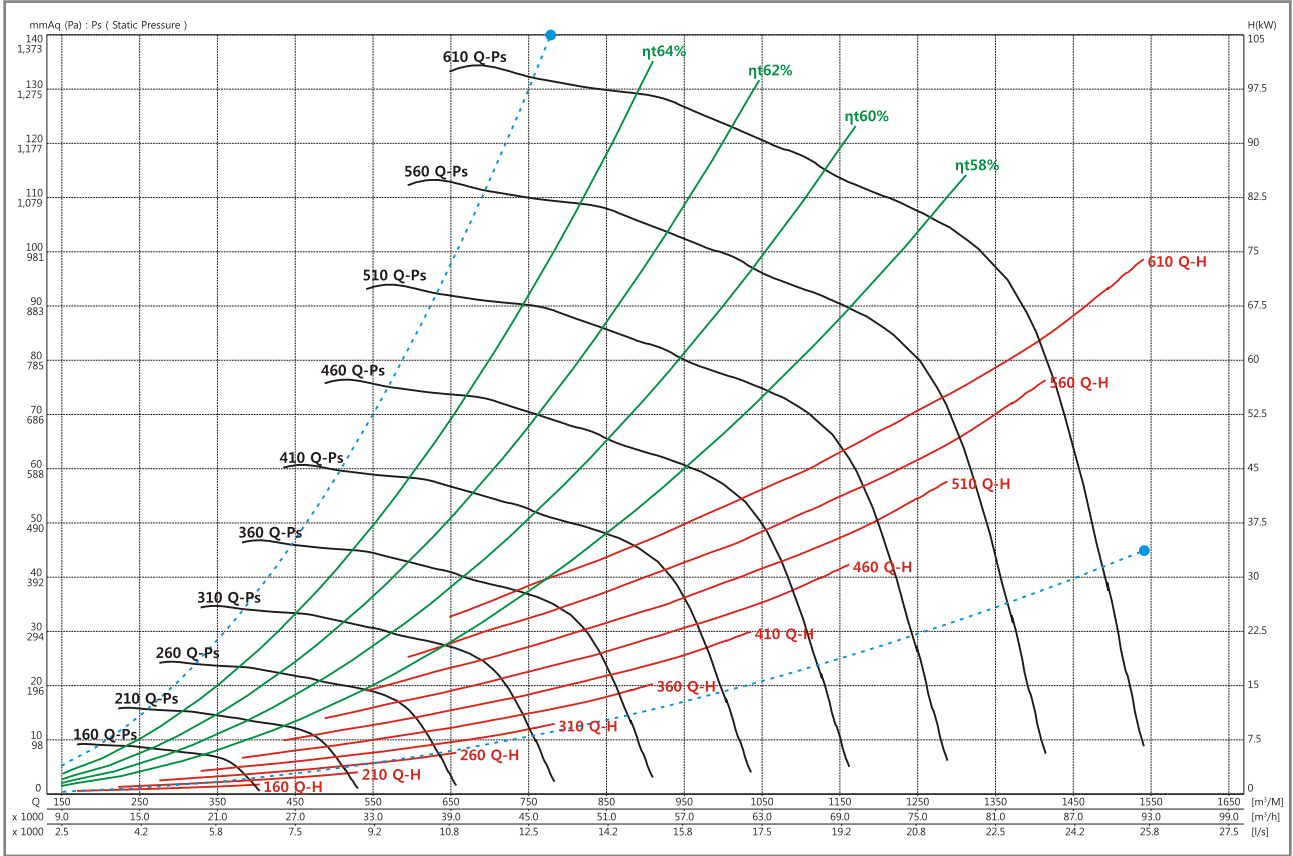

Air flow (m³/min)	Outlet Vel (m/sec)	10 mmAq (98 Pa)				20 mmAq (196 Pa)				30 mmAq (294 Pa)				40 mmAq (392 Pa)				50 mmAq (490 Pa)				
		rpm	BkW	η _t	PWL	rpm	BkW	η _t	PWL	rpm	BkW	η _t	PWL	rpm	BkW	η _t	PWL	rpm	BkW	η _t	PWL	
300	6.39	175	1.00	61.5	69	237	1.75	62.8	73													
350	7.46	182	1.29	59.2	73	240	2.10	63.5	75													
400	8.52	189	1.65	57.2	75	245	2.57	62.2	78	292	3.55	63.4	80									
450	9.59	200	2.14	53.7	79	251	3.08	61.0	80	295	4.13	63.3	82	337	5.30	63.2	83					
500	10.66	216	2.81	49.2	82	258	3.73	59.0	82	301	4.86	62.0	83	339	6.02	63.6	85	377	7.36	63.2	86	
550	11.72	233	3.65	45.0	85	264	4.43	57.7	84	307	5.64	61.0	85	344	6.96	62.5	86	379	8.26	63.5	88	
600	12.79	251	4.66	42.0	87	274	5.28	55.6	86	314	6.59	59.3	87	350	7.97	61.5	88	383	9.34	62.9	89	
650	13.85	269	5.87	39.2	89	287	6.38	52.7	89	321	7.60	58.2	89	357	9.03	60.7	90	389	10.6	61.9	90	
700	14.92	288	7.27	37.1	91	302	7.71	49.7	91	328	8.74	57.0	90	364	10.4	59.2	91	395	11.9	61.1	92	
750	15.98	306	8.86	35.3	93	320	9.34	46.6	93	339	10.1	55.0	92	370	11.7	58.2	93	403	13.4	59.9	93	
800	17.05	325	10.7	34.0	95	337	11.2	44.0	94	352	11.8	52.6	94	378	13.2	57.2	94	409	15.0	58.8	95	
850	18.11	344	12.8	32.8	96	355	13.3	41.8	96	368	13.9	50.0	96	388	15.0	55.6	95	415	16.7	58.0	96	

Air flow (m³/min)	Outlet Vel (m/sec)	60 mmAq (588 Pa)				70 mmAq (686 Pa)				80 mmAq (785 Pa)				90 mmAq (883 Pa)				100 mmAq (981 Pa)				
		rpm	BkW	η _t	PWL	rpm	BkW	η _t	PWL	rpm	BkW	η _t	PWL	rpm	BkW	η _t	PWL	rpm	BkW	η _t	PWL	
300	6.39																					
350	7.46																					
400	8.52																					
450	9.59																					
500	10.66																					
550	11.72	413	9.72	63.2	89	444	11.2	62.8	90													
600	12.79	415	10.8	63.5	90	446	12.4	63.2	91	475	14.0	62.8	92									
650	13.85	419	12.1	63.0	91	448	13.7	63.5	92	478	15.4	63.3	93	505	17.1	62.9	94					
700	14.92	425	13.5	62.1	93	452	15.1	63.1	93	480	16.8	63.5	94	507	18.7	63.4	95	533	20.6	63.1	95	
750	15.98	431	15.1	61.2	94	458	16.8	62.2	94	484	18.6	63.0	95	509	20.3	63.6	96	535	22.3	63.4	96	
800	17.05	437	16.7	60.6	95	464	18.7	61.4	96	490	20.5	62.2	96	514	22.3	63.0	97	537	24.2	63.6	97	
850	18.11	445	18.7	59.3	96	470	20.5	60.9	97	496	22.6	61.5	97	520	24.5	62.2	98	542	26.5	62.9	98	

- Power rating BkW does not include transmission losses.
 - The A-weighted sound ratings shown have been calculated per AMCA International Standard 301. Values shown are for inlet LwiA sound power levels for installation type B (free inlet, ducted outlet).
 - Performance certified is for installation type B: free inlet, ducted outlet. Performance ratings do not include the effects of appurtenance (accessories).

GSF-SS Version 11.0_May2024

GSF-SS series

SIROCCO FAN

www.gsfan.co.kr



GSF-7SS

FEG 67

Wheel dia	1050 mm	Tip Speed =	0.05498 * rpm	Outlet Dim'	845 * 1065	Outlet Area	0.8999 m ²	Class 1	455 rpm	Class 2	573 rpm	Not Applicable
-----------	---------	-------------	---------------	-------------	------------	-------------	-----------------------	---------	---------	---------	---------	----------------

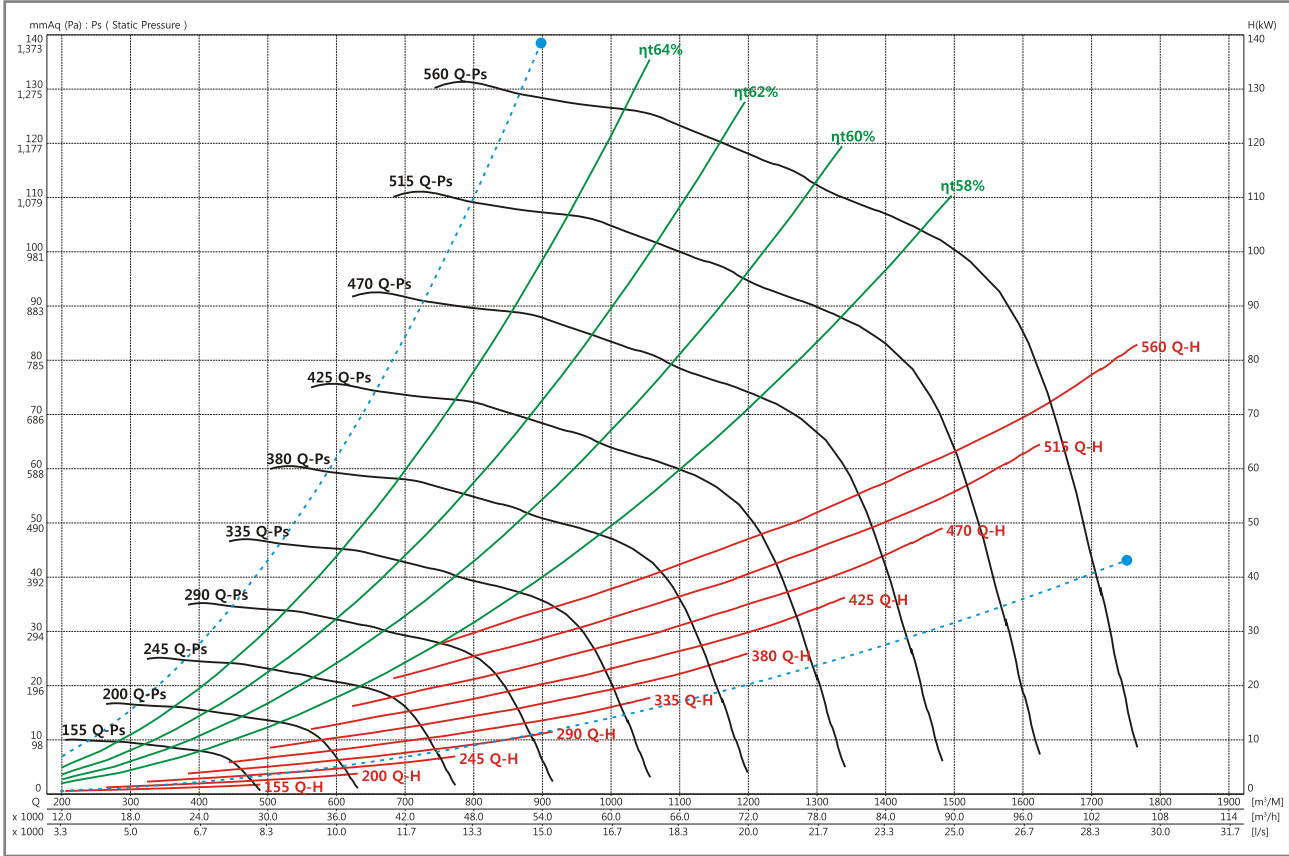

Air flow (m ³ /min)	Outlet Vel (m/sec)	10 mmAq (98 Pa)				20 mmAq (196 Pa)				30 mmAq (294 Pa)				40 mmAq (392 Pa)				50 mmAq (490 Pa)				
		rpm	BkW	η _t	PWL	rpm	BkW	η _t	PWL	rpm	BkW	η _t	PWL	rpm	BkW	η _t	PWL	rpm	BkW	η _t	PWL	
		m ⁻¹	kW	%	LwIA	m ⁻¹	kW	%	LwIA	m ⁻¹	kW	%	LwIA	m ⁻¹	kW	%	LwIA	m ⁻¹	kW	%	LwIA	
450	8.33	174	1.81	57.7	75	226	2.83	62.5	77	271	3.96	63.2	79									
500	9.26	182	2.25	55.3	78	231	3.35	61.2	79	273	4.51	63.6	81	313	5.88	62.9	83					
550	10.19	193	2.84	51.6	81	237	3.94	59.9	81	277	5.20	62.6	83	315	6.56	63.4	84	349	8.03	62.8	86	
600	11.11	206	3.58	47.7	83	242	4.59	58.7	83	282	5.95	61.5	84	317	7.35	63.4	86	351	8.87	63.4	87	
650	12.04	220	4.46	44.4	85	247	5.30	57.3	85	287	6.75	60.8	86	321	8.29	62.3	87	353	9.80	63.6	88	
700	12.96	235	5.52	42.3	87	255	6.19	55.4	87	293	7.75	59.2	88	326	9.31	61.4	88	357	11.0	62.8	89	
750	13.89	249	6.71	38.9	89	266	7.30	53.1	89	298	8.75	58.4	89	331	10.4	60.8	90	361	12.1	61.9	91	
800	14.82	264	8.08	37.3	91	278	8.60	50.3	91	304	9.88	57.3	90	337	11.7	59.4	91	366	13.5	61.1	92	
850	15.74	279	9.63	35.8	93	291	10.1	47.3	92	311	11.2	55.6	92	342	13.0	58.6	92	372	14.9	60.5	93	
900	16.67	294	11.3	34.8	94	306	11.9	45.6	94	321	12.7	53.8	94	348	14.5	57.8	93	377	16.5	59.3	94	
950	17.59	309	13.3	33.5	96	320	13.9	43.2	95	333	14.6	51.6	95	354	16.0	56.7	95	382	18.1	58.6	95	
1000	18.52	324	15.4	32.1	97	334	16.0	41.0	97	346	16.7	49.5	97	363	17.9	55.2	96	388	20.0	57.8	96	

Air flow (m ³ /min)	Outlet Vel (m/sec)	60 mmAq (588 Pa)				70 mmAq (686 Pa)				80 mmAq (785 Pa)				90 mmAq (883 Pa)				100 mmAq (981 Pa)				
		rpm	BkW	η _t	PWL	rpm	BkW	η _t	PWL	rpm	BkW	η _t	PWL	rpm	BkW	η _t	PWL	rpm	BkW	η _t	PWL	
		m ⁻¹	kW	%	LwIA	m ⁻¹	kW	%	LwIA	m ⁻¹	kW	%	LwIA	m ⁻¹	kW	%	LwIA	m ⁻¹	kW	%	LwIA	
450	8.33																					
500	9.26																					
550	10.19																					
600	11.11	382	10.5	62.8	88																	
650	12.04	384	11.5	63.3	89	413	13.3	62.8	90													
700	12.96	386	12.6	63.5	90	415	14.5	63.3	91	442	16.4	62.8	92									
750	13.89	389	13.9	63.1	91	417	15.8	63.5	92	444	17.7	63.3	93	469	19.8	62.9	94					
800	14.82	394	15.4	62.3	93	419	17.1	63.3	93	445	19.1	63.5	94	471	21.3	63.3	95	495	23.5	63.0	95	
850	15.74	399	16.9	61.5	94	424	18.9	62.4	94	448	20.8	63.4	95	472	22.9	63.5	96	497	25.2	63.3	96	
900	16.67	403	18.4	61.0	95	429	20.6	61.8	95	453	22.7	62.6	96	475	24.7	63.4	96	498	27.0	63.5	97	
950	17.59	410	20.4	60.0	96	434	22.5	61.1	96	457	24.6	61.9	97	480	26.9	62.6	97	501	29.0	63.4	98	
1000	18.52	415	22.3	59.1	97	439	24.3	60.7	97	462	26.8	61.3	98	484	29.1	62.0	98	505	31.4	62.6	99	

- Power rating BkW does not include transmission losses.
 - The A-weighted sound ratings shown have been calculated per AMCA International Standard 301. Values shown are for inlet LwIA sound power levels for installation type B(free inlet, ducted outlet).
 - Performance certified is for installation type B: free inlet, ducted outlet. Performance ratings do not include the effects of appurtenance (accessories).

GSF-SS Version 11.0_May2024

SIROCCO FAN
GSF-SS series

GSF-SS series

SIROCCO FAN
www.gsfan.co.kr



GSF-8SS

FEG 75

Wheel dia	1200 mm	Tip Speed = 0.06283 * rpm	Outlet Dim'	965 * 1220	Outlet Area	1.1773 m ²	Class 1	398 rpm	Class 2	501 rpm	Not Applicable
-----------	---------	---------------------------	-------------	------------	-------------	-----------------------	---------	---------	---------	---------	----------------

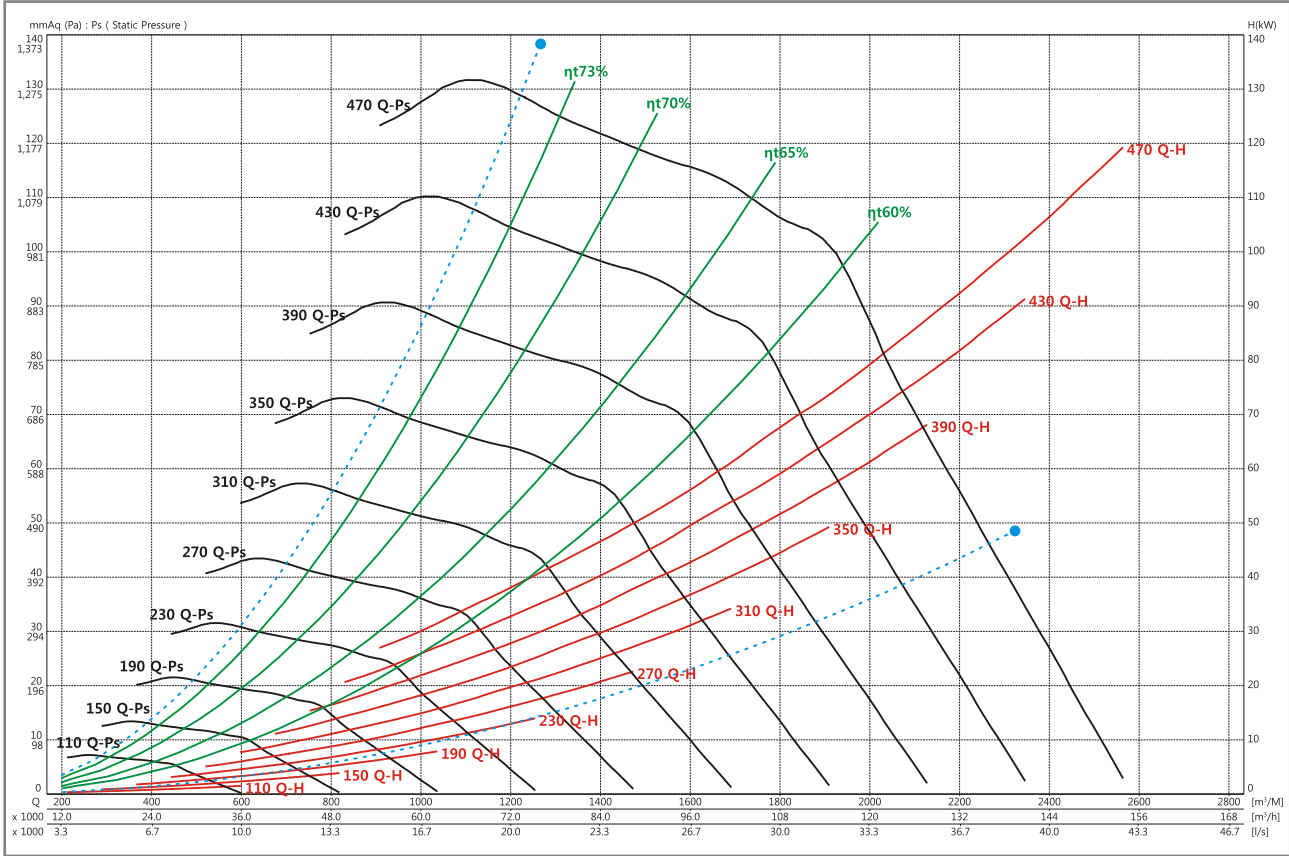

Air flow (m³/min)	Outlet Vel (m/sec)	10 mmAq (98 Pa)				20 mmAq (196 Pa)				30 mmAq (294 Pa)				40 mmAq (392 Pa)				50 mmAq (490 Pa)				
		rpm	BkW	η _t	PWL	rpm	BkW	η _t	PWL	rpm	BkW	η _t	PWL	rpm	BkW	η _t	PWL	rpm	BkW	η _t	PWL	
530	7.50	142	1.79	64.3	72	189	2.81	72.7	76													
600	8.49	148	2.29	61.5	76	192	3.39	70.2	78	228	4.52	74.7	81									
670	9.48	158	3.00	56.1	79	196	4.11	68.1	79	232	5.38	72.0	82									
740	10.48	170	3.90	52.3	83	201	4.97	65.1	81	236	6.32	70.1	83	266	7.73	73.0	86					
810	11.47	180	4.88	48.6	85	206	5.93	62.6	83	239	7.35	68.3	85	270	8.92	71.2	87	296	10.4	73.4	88	
880	12.46	191	6.05	46.2	87	213	7.05	59.6	86	244	8.61	66.2	86	274	10.2	69.6	88	300	11.9	71.7	89	
950	13.45	202	7.40	44.1	89	224	8.54	56.1	89	249	10.0	63.3	87	277	11.6	68.0	89	304	13.5	70.2	90	
1020	14.44	213	8.94	42.2	91	235	10.3	52.7	91	254	11.4	62.1	90	281	13.3	65.9	90	308	15.2	68.8	91	
1090	15.43	225	10.7	41.0	93	246	12.1	50.4	93	263	13.3	59.3	92	287	15.2	63.5	91	311	17.0	67.3	92	
1160	16.42	236	12.7	39.6	95	257	14.3	48.4	95	274	15.6	56.4	94	292	17.1	62.5	93	316	19.2	65.3	93	
1230	17.41	248	14.9	38.6	96	268	16.6	46.6	96	285	18.1	53.7	96	300	19.4	60.7	95	322	21.7	63.3	94	
1300	18.40	259	17.3	37.5	98	279	19.2	45.1	98	296	20.9	51.4	97	310	22.2	57.8	97	327	24.0	62.5	96	

Air flow (m³/min)	Outlet Vel (m/sec)	60 mmAq (588 Pa)				70 mmAq (686 Pa)				80 mmAq (785 Pa)				90 mmAq (883 Pa)				100 mmAq (981 Pa)				
		rpm	BkW	η _t	PWL	rpm	BkW	η _t	PWL	rpm	BkW	η _t	PWL	rpm	BkW	η _t	PWL	rpm	BkW	η _t	PWL	
530	7.50																					
600	8.49																					
670	9.48																					
740	10.48																					
810	11.47																					
880	12.46	324	13.5	73.7	91																	
950	13.45	328	15.3	71.9	91	350	17.1	73.7	93													
1020	14.44	332	17.1	70.6	92	354	19.1	72.1	93	374	20.9	73.6	95	392	22.7	75.1	95					
1090	15.43	336	19.1	69.3	93	358	21.2	70.9	94	379	23.4	72.1	95	398	25.4	73.4	96	415	27.2	74.8	97	
1160	16.42	339	21.2	68.1	94	362	23.5	69.6	95	382	25.7	71.0	96	402	28	72.1	97	420	30.2	73.2	98	
1230	17.41	343	23.7	66.5	95	365	25.9	68.5	96	386	28.3	69.8	97	405	30.6	71.0	97	424	33.1	71.9	98	
1300	18.40	349	26.5	64.5	96	369	28.7	67.2	97	390	31.1	68.7	97	409	33.5	69.9	98	428	36.1	71.0	99	

- Power rating BkW does not include transmission losses.
 - The A-weighted sound ratings shown have been calculated per AMCA International Standard 301. Values shown are for inlet LwIA sound power levels for installation type B (free inlet, ducted outlet).
 - Performance certified is for installation type B: free inlet, ducted outlet. Performance ratings do not include the effects of appurtenance (accessories).

GSF-SS series

SIROCCO FAN

www.gsfan.co.kr



GSF-9SS

FEG 75

Wheel dia	1350 mm	Tip Speed = 0.07069 * rpm	Outlet Dim'	1080 * 1370	Outlet Area	1.4796 m ²	Class 1	354 rpm	Class 2	446 rpm	Not Applicable
-----------	---------	---------------------------	-------------	-------------	-------------	-----------------------	---------	---------	---------	---------	----------------

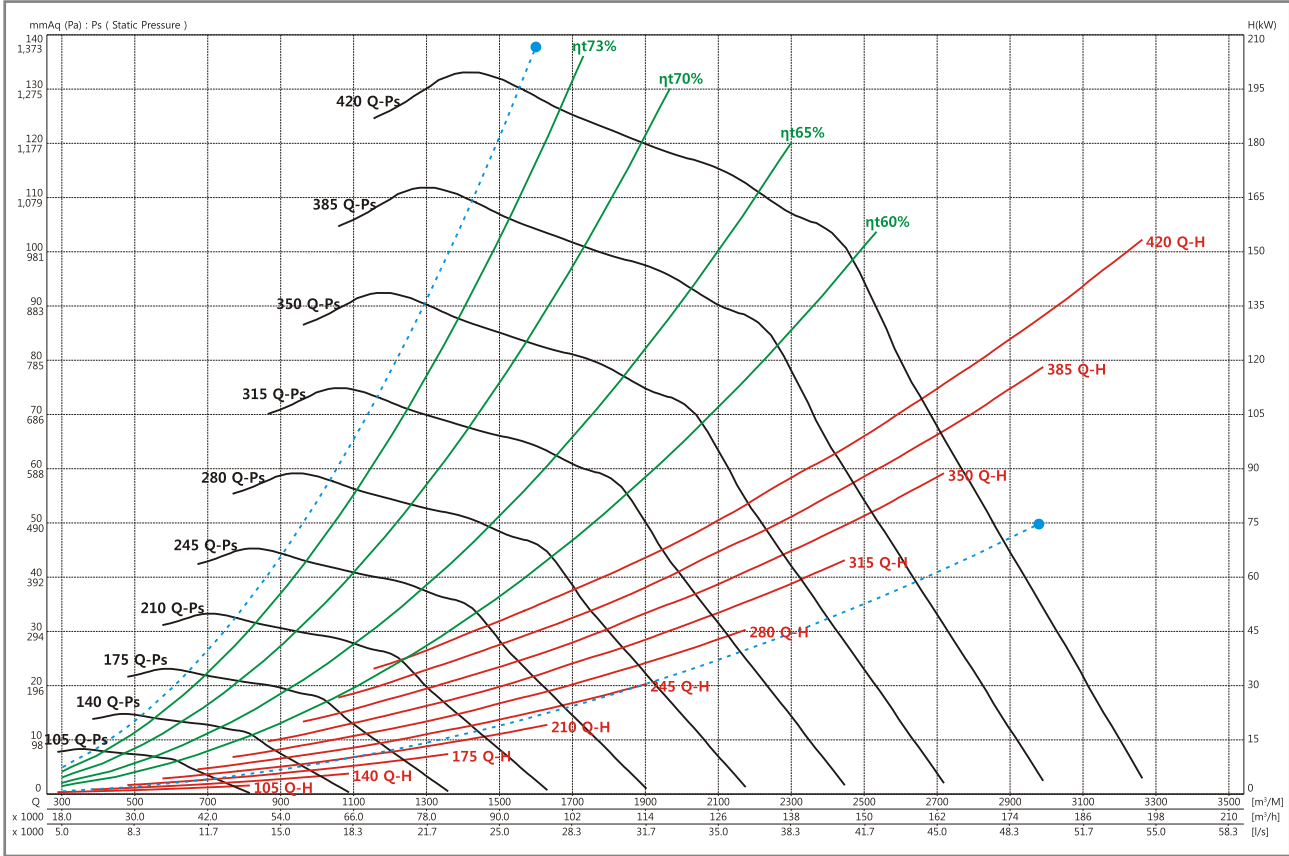

Air flow (m³/min)	Outlet Vel (m/sec)	10 mmAq (98 Pa)				20 mmAq (196 Pa)				30 mmAq (294 Pa)				40 mmAq (392 Pa)				50 mmAq (490 Pa)				
		rpm	BkW	η _t	PWL	rpm	BkW	η _t	PWL	rpm	BkW	η _t	PWL	rpm	BkW	η _t	PWL	rpm	BkW	η _t	PWL	
		m ⁻¹	kW	%	LwIA	m ⁻¹	kW	%	LwIA	m ⁻¹	kW	%	LwIA	m ⁻¹	kW	%	LwIA	m ⁻¹	kW	%	LwIA	
720	8.11	129	2.61	62.7	74	169	3.93	71.2	77													
800	9.01	136	3.31	59.6	78	173	4.72	69.3	79	204	6.21	73.2	82									
880	9.91	144	4.17	54.4	81	175	5.54	67.0	80	207	7.21	71.3	83	234	8.86	74.6	85					
960	10.81	153	5.22	50.9	84	180	6.63	64.1	82	211	8.36	69.7	84	237	10.1	72.4	86	259	11.8	75.0	88	
1040	11.71	162	6.43	48.5	86	184	7.71	62.5	84	213	9.53	68.0	85	240	11.5	70.9	87	264	13.5	73.1	89	
1120	12.62	171	7.81	46.3	88	190	9.04	59.4	87	217	11.0	65.9	87	244	13.1	69.5	88	267	15.2	71.6	90	
1200	13.52	179	9.29	44.0	90	199	10.8	56.3	89	222	12.7	63.5	88	246	14.7	68.1	89	270	17.0	70.2	91	
1280	14.42	188	11.0	42.3	92	208	12.7	53.4	91	225	14.2	62.3	90	250	16.6	66.4	90	273	18.9	69.0	92	
1360	15.32	198	13.1	41.4	93	217	14.9	51.1	93	232	16.3	60.1	92	254	18.7	64.0	91	276	21.0	67.8	92	
1440	16.22	207	15.3	40.2	95	225	17.1	48.8	95	240	18.7	57.1	94	258	20.9	62.7	93	280	23.5	66.2	93	
1520	17.12	216	17.7	39.0	96	234	19.7	47.2	96	249	21.5	54.6	95	263	23.2	61.5	95	284	26.2	64.0	94	
1600	18.02	225	20.3	38.0	98	243	22.6	45.8	97	258	24.6	52.4	97	271	26.3	59.3	96	288	28.9	62.8	96	

Air flow (m³/min)	Outlet Vel (m/sec)	60 mmAq (588 Pa)				70 mmAq (686 Pa)				80 mmAq (785 Pa)				90 mmAq (883 Pa)				100 mmAq (981 Pa)				
		rpm	BkW	η _t	PWL	rpm	BkW	η _t	PWL	rpm	BkW	η _t	PWL	rpm	BkW	η _t	PWL	rpm	BkW	η _t	PWL	
		m ⁻¹	kW	%	LwIA	m ⁻¹	kW	%	LwIA	m ⁻¹	kW	%	LwIA	m ⁻¹	kW	%	LwIA	m ⁻¹	kW	%	LwIA	
720	8.11																					
800	9.01																					
880	9.91																					
960	10.81																					
1040	11.71																					
1120	12.62	288	17.3	73.5	91																	
1200	13.52	292	19.3	72.0	92	311	21.5	73.8	93													
1280	14.42	295	21.4	70.9	93	314	23.8	72.2	94	332	26.1	73.8	95									
1360	15.32	298	23.7	69.6	93	317	26.2	71.1	94	336	28.9	72.4	96	352	31.2	73.8	96	367	33.5	75.1	97	
1440	16.22	300	26.0	68.5	94	321	28.9	70.0	95	339	31.6	71.3	96	356	34.3	72.4	97	372	37.0	73.7	98	
1520	17.12	303	28.6	67.2	95	323	31.5	68.9	96	342	34.5	70.2	97	359	37.4	71.4	98	375	40.2	72.4	98	
1600	18.02	307	31.6	65.4	96	326	34.4	67.9	97	345	37.5	69.3	97	362	40.6	70.4	98	378	43.6	71.4	99	

- Power rating BkW does not include transmission losses.
 - The A-weighted sound ratings shown have been calculated per AMCA International Standard 301. Values shown are for inlet LwIA sound power levels for installation type B (free inlet, ducted outlet).
 - Performance certified is for installation type B: free inlet, ducted outlet. Performance ratings do not include the effects of appurtenance (accessories).

SIROCCO FAN
GSF-SS series

GSF-SS series

SIROCCO FAN

www.gsfan.co.kr



GSF-10SS

FEG 75

Wheel dia	1500 mm	Tip Speed = 0.07854 * rpm	Outlet Dim'	1200 * 1525	Outlet Area	1.8300 m ²	Class 1	318 rpm	Class 2	401 rpm	Not Applicable
-----------	---------	---------------------------	-------------	-------------	-------------	-----------------------	---------	---------	---------	---------	----------------

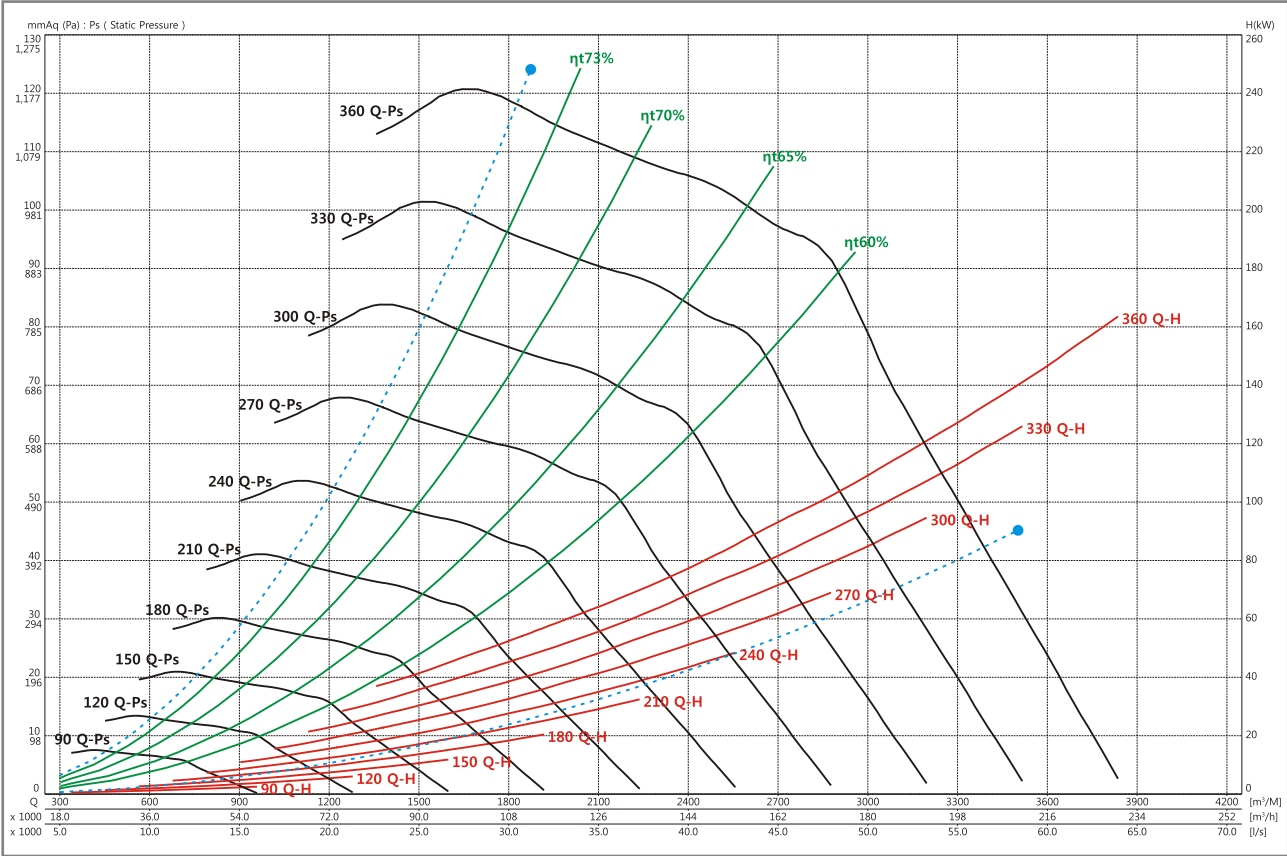

Air flow (m³/min)	Outlet Vel (m/sec)	10 mmAq (98 Pa)				20 mmAq (196 Pa)				30 mmAq (294 Pa)				40 mmAq (392 Pa)				50 mmAq (490 Pa)				
		rpm	BkW	η _t	PWL	rpm	BkW	η _t	PWL	rpm	BkW	η _t	PWL	rpm	BkW	η _t	PWL	rpm	BkW	η _t	PWL	
		m ⁻¹	kW	%	LwIA	m ⁻¹	kW	%	LwIA	m ⁻¹	kW	%	LwIA	m ⁻¹	kW	%	LwIA	m ⁻¹	kW	%	LwIA	
1000	9.11	123	4.19	58.6	78	156	5.94	69.0	79	184	7.82	72.9	82									
1100	10.02	131	5.33	54.1	82	158	7.00	66.7	81	187	9.09	71.1	83	211	11.2	74.2	86					
1200	10.93	139	6.67	50.6	85	162	8.34	63.6	83	190	10.5	69.4	84	214	12.8	72.1	87	235	15.0	74.9	89	
1300	11.84	147	8.19	48.0	87	166	9.72	62.1	85	192	12.0	67.7	86	217	14.6	70.7	88	238	17.0	72.8	89	
1400	12.75	155	9.93	45.8	89	173	11.6	59.3	87	196	13.9	65.4	87	220	16.5	69.2	89	241	19.1	71.4	90	
1500	13.66	163	11.9	43.9	91	181	13.8	56.0	90	200	16.0	63.1	89	222	18.5	67.8	90	244	21.5	70.0	91	
1600	14.57	171	14.1	42.2	92	189	16.2	52.9	92	204	18.1	62.1	91	225	20.9	65.7	91	246	23.8	68.7	92	
1700	15.48	180	16.7	41.2	94	197	19.0	50.7	94	210	20.7	59.3	93	230	23.8	63.7	92	249	26.6	67.4	93	
1800	16.39	188	19.5	39.8	96	205	22.0	48.8	95	218	23.9	56.6	94	233	26.4	62.6	94	252	29.6	65.5	94	
1900	17.30	196	22.5	38.6	97	213	25.3	47.1	97	226	27.4	54.0	96	238	29.5	60.9	95	257	33.2	63.7	95	
2000	18.21	205	26.0	38.0	98	221	28.9	45.6	98	235	31.5	52.3	98	246	33.5	58.8	97	260	36.4	62.6	96	
2100	19.13	213	29.7	36.9	100	229	32.8	44.3	99	242	35.4	50.2	99	254	37.9	56.5	99	265	40.3	61.5	98	

Air flow (m³/min)	Outlet Vel (m/sec)	60 mmAq (588 Pa)				70 mmAq (686 Pa)				80 mmAq (785 Pa)				90 mmAq (883 Pa)				100 mmAq (981 Pa)				
		rpm	BkW	η _t	PWL	rpm	BkW	η _t	PWL	rpm	BkW	η _t	PWL	rpm	BkW	η _t	PWL	rpm	BkW	η _t	PWL	
		m ⁻¹	kW	%	LwIA	m ⁻¹	kW	%	LwIA	m ⁻¹	kW	%	LwIA	m ⁻¹	kW	%	LwIA	m ⁻¹	kW	%	LwIA	
1000	9.11																					
1100	10.02																					
1200	10.93																					
1300	11.84	256	19.3	75.1	91																	
1400	12.75	260	21.8	73.2	92	276	24.1	75.1	93													
1500	13.66	263	24.3	71.8	92	280	27.0	73.4	94	295	29.5	75.1	95									
1600	14.57	266	27.0	70.6	93	284	30.1	72.1	94	300	33.0	73.5	95	314	35.7	75.0	96					
1700	15.48	269	29.8	69.4	94	286	33.0	70.9	95	303	36.4	72.1	96	318	39.5	73.4	97	332	42.4	74.9	98	
1800	16.39	271	32.8	68.3	95	289	36.3	69.8	96	306	39.8	71.1	97	321	43.2	72.2	98	335	46.5	73.3	98	
1900	17.30	274	36.3	66.9	96	292	39.8	68.7	96	308	43.3	70.0	97	324	47.1	71.2	98	338	50.6	72.1	99	
2000	18.21	278	40.2	65.1	97	294	43.5	67.6	97	311	47.3	69.0	98	327	51.3	70.2	99	341	54.9	71.2	100	
2100	19.13	282	44.3	63.4	98	297	47.6	66.1	98	313	51.3	68.0	99	329	55.4	69.2	99	344	59.5	70.2	100	

- Power rating BkW does not include transmission losses.
 - The A-weighted sound ratings shown have been calculated per AMCA International Standard 301. Values shown are for inlet LwIA sound power levels for installation type B (free inlet, ducted outlet).
 - Performance certified is for installation type B: free inlet, ducted outlet. Performance ratings do not include the effects of appurtenance (accessories).

GSF-SS series

SIROCCO FAN
www.gsfan.co.kr



GSF-11SS

FEG 75

Wheel dia	1650 mm	Tip Speed = 0.08639 * rpm	Outlet Dim'	1320 * 1675	Outlet Area	2.2110 m ²	Class 1	289 rpm	Class 2	365 rpm	Not Applicable
-----------	---------	---------------------------	-------------	-------------	-------------	-----------------------	---------	---------	---------	---------	----------------

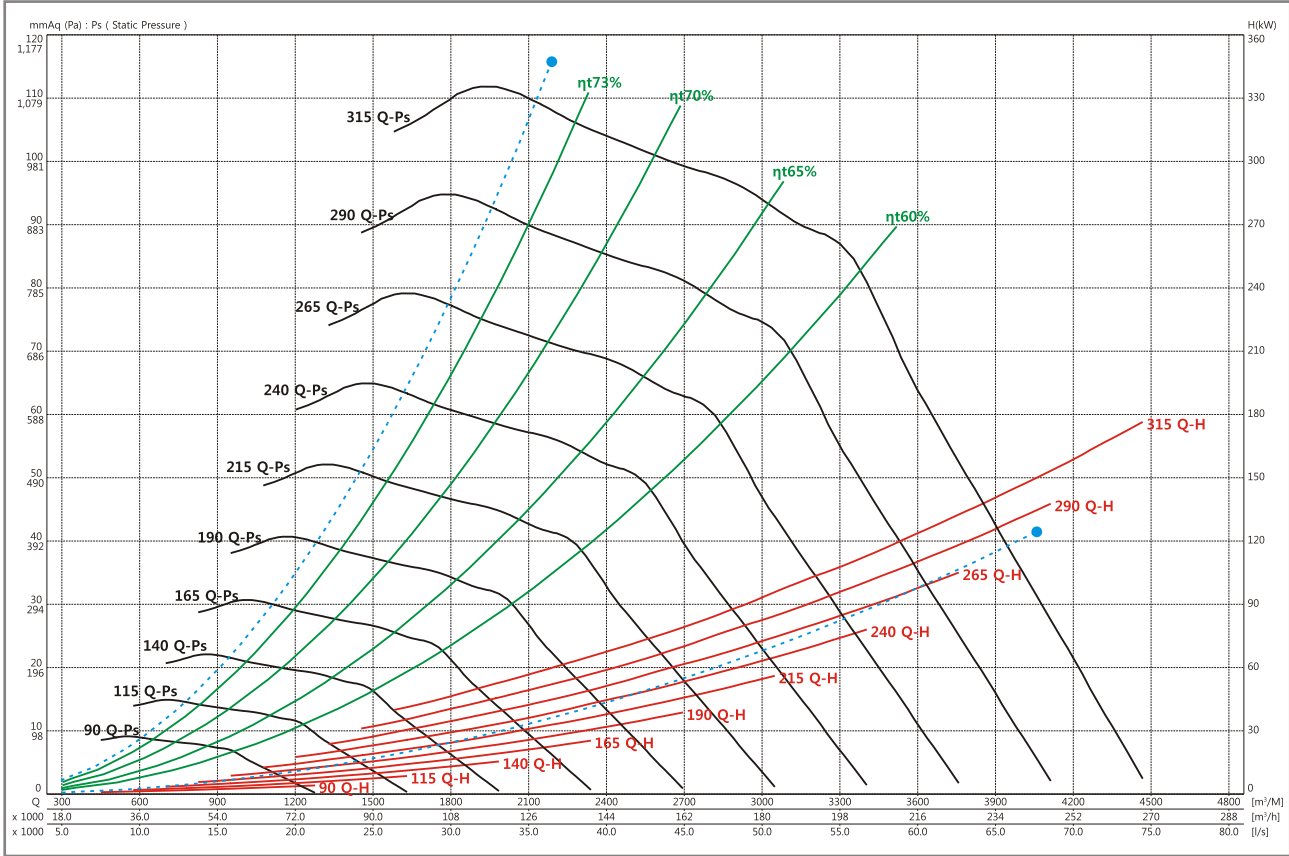

Air flow (m³/min)	Outlet Vel (m/sec)	10 mmAq (98 Pa)				20 mmAq (196 Pa)				30 mmAq (294 Pa)				40 mmAq (392 Pa)				50 mmAq (490 Pa)			
		rpm	BkW	ηt	PWL	rpm	BkW	ηt	PWL	rpm	BkW	ηt	PWL	rpm	BkW	ηt	PWL	rpm	BkW	ηt	PWL
1080	8.14	106	3.95	62.7	75	139	5.96	71.2	78												
1200	9.05	111	4.95	58.8	79	141	7.04	69.1	80	167	9.32	73.1	83								
1320	9.95	118	6.29	53.9	82	144	8.39	67.1	81	170	10.9	71.3	84	191	13.2	74.4	86				
1440	10.85	126	7.92	51.2	85	147	9.94	63.9	83	172	12.5	69.5	85	194	15.3	72.3	87	213	17.9	75.1	89
1560	11.76	133	9.72	48.4	87	150	11.5	62.2	85	175	14.4	68.0	86	197	17.4	70.8	88	216	20.3	73.0	90
1680	12.66	140	11.8	46.0	89	156	13.7	59.3	88	178	16.6	65.8	87	199	19.6	69.3	89	219	22.9	71.5	90
1800	13.57	147	14.0	43.9	91	163	16.2	55.9	90	181	19.0	63.3	89	201	22.0	67.9	90	221	25.5	70.1	91
1920	14.47	155	16.8	42.7	93	171	19.2	53.5	92	185	21.5	62.3	91	204	24.9	66.0	91	224	28.5	68.9	92
2040	15.38	162	19.7	41.0	94	178	22.4	50.9	94	190	24.6	59.7	93	208	28.2	63.8	92	226	31.7	67.7	93
2160	16.28	170	23.1	40.1	96	185	25.9	48.9	96	197	28.3	56.9	95	212	31.6	62.7	94	229	35.3	65.9	94
2280	17.19	177	26.6	38.8	97	192	29.8	47.1	97	205	32.6	54.9	96	216	35.1	61.5	95	233	39.5	63.9	95
2400	18.09	185	30.7	38.0	99	199	34.0	45.5	98	212	37.2	52.4	98	222	39.6	58.9	97	236	43.5	62.7	96

Air flow (m³/min)	Outlet Vel (m/sec)	60 mmAq (588 Pa)				70 mmAq (686 Pa)				80 mmAq (785 Pa)				90 mmAq (883 Pa)				100 mmAq (981 Pa)			
		rpm	BkW	ηt	PWL	rpm	BkW	ηt	PWL	rpm	BkW	ηt	PWL	rpm	BkW	ηt	PWL	rpm	BkW	ηt	PWL
1080	8.14																				
1200	9.05																				
1320	9.95																				
1440	10.85																				
1560	11.76																				
1680	12.66	236	26.0	73.4	92																
1800	13.57	239	29.1	71.9	93	255	32.4	73.7	94												
1920	14.47	241	32.1	70.7	93	257	35.8	72.1	95	272	39.4	73.7	96								
2040	15.38	244	35.6	69.5	94	260	39.5	71.1	95	275	43.4	72.3	96	289	47.2	73.7	97	301	50.6	75.0	98
2160	16.28	246	39.1	68.4	95	262	43.2	69.9	96	277	47.3	71.2	97	291	51.5	72.3	98	304	55.4	73.5	99
2280	17.19	248	43.0	67.0	96	265	47.5	68.9	97	280	51.9	70.2	98	294	56.2	71.3	98	307	60.5	72.3	99
2400	18.09	252	47.8	65.4	97	267	51.9	67.8	98	282	56.3	69.1	98	297	61.2	70.4	99	310	65.7	71.4	100

- Power rating BkW does not include transmission losses.
 - The A-weighted sound ratings shown have been calculated per AMCA International Standard 301. Values shown are for inlet LwiA sound power levels for installation type B (free inlet, ducted outlet).
 - Performance certified is for installation type B: free inlet, ducted outlet. Performance ratings do not include the effects of appurtenance (accessories).

GSF-SS Version 11.0_May2024

GSF-SS series

SIROCCO FAN

www.gsfan.co.kr



GSF-12SS

FEG 75

Wheel dia	1800 mm	Tip Speed = 0.09425 * rpm	Outlet Dim'	1440 * 1830	Outlet Area	2.6352 m ²	Class 1	265 rpm	Class 2	334 rpm	Not Applicable
-----------	---------	---------------------------	-------------	-------------	-------------	-----------------------	---------	---------	---------	---------	----------------

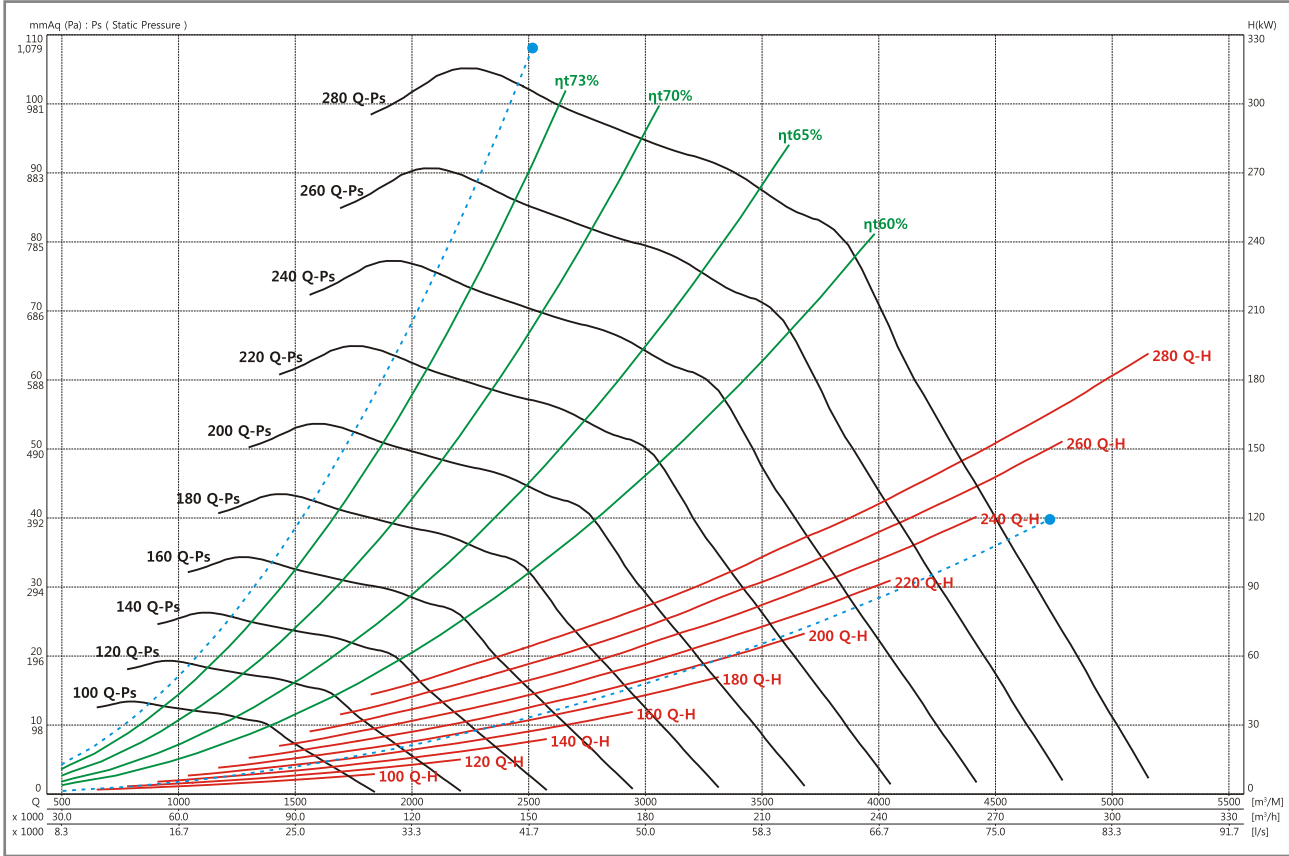

Air flow (m³/min)	Outlet Vel (m/sec)	10 mmAq (98 Pa)				20 mmAq (196 Pa)				30 mmAq (294 Pa)				40 mmAq (392 Pa)				50 mmAq (490 Pa)				
		rpm	BkW	ηt	PWL	rpm	BkW	ηt	PWL	rpm	BkW	ηt	PWL	rpm	BkW	ηt	PWL	rpm	BkW	ηt	PWL	
1250	7.91					127	6.80	71.8	78													
1400	8.85	101	5.65	60.3	78	129	8.13	69.5	80	153	10.8	73.7	83									
1550	9.80	108	7.31	55.7	81	131	9.68	67.3	81	155	12.6	71.4	84	175	15.5	74.8	86					
1700	10.75	115	9.26	51.6	85	135	11.7	64.3	83	158	14.8	69.7	85	178	18.0	72.5	87	194	20.8	75.1	89	
1850	11.70	121	11.4	47.9	87	138	13.7	62.5	85	160	17.0	68.1	86	180	20.5	70.9	88	198	24.1	73.1	90	
2000	12.65	128	13.9	45.7	89	143	16.3	59.3	88	163	19.7	65.8	88	183	23.4	69.4	89	201	27.3	71.5	91	
2150	13.60	135	16.9	43.7	91	150	19.5	56.0	90	167	22.9	63.4	89	185	26.5	67.9	90	203	30.6	70.1	92	
2300	14.55	143	20.4	42.7	93	157	23.2	52.8	93	170	26.0	62.2	91	188	30.1	65.9	91	205	34.2	68.7	93	
2450	15.50	150	24.1	41.1	95	164	27.3	50.5	95	175	29.9	59.2	93	192	34.4	63.7	93	207	38.2	67.3	93	
2600	16.44	157	28.2	39.7	96	171	31.8	48.6	96	182	34.7	56.4	95	194	38.1	62.5	94	211	43.1	65.6	95	
2750	17.39	164	32.8	38.5	98	178	36.8	46.9	98	189	40.0	53.8	97	199	43.0	60.8	96	214	48.1	63.5	96	
2900	18.34	172	38.2	37.9	99	185	42.3	45.4	99	196	45.9	51.6	99	206	49.1	58.5	98	217	53.1	62.6	97	

Air flow (m³/min)	Outlet Vel (m/sec)	60 mmAq (588 Pa)				70 mmAq (686 Pa)				80 mmAq (785 Pa)				90 mmAq (883 Pa)				100 mmAq (981 Pa)				
		rpm	BkW	ηt	PWL	rpm	BkW	ηt	PWL	rpm	BkW	ηt	PWL	rpm	BkW	ηt	PWL	rpm	BkW	ηt	PWL	
1250	7.91																					
1400	8.85																					
1550	9.80																					
1700	10.75																					
1850	11.70																					
2000	12.65	216	30.9	73.3	92																	
2150	13.60	219	34.7	71.9	93	234	38.9	73.6	94													
2300	14.55	221	38.6	70.5	94	236	43.1	72.0	95	250	47.4	73.6	96	262	51.4	75.1	97					
2450	15.50	224	43.0	69.4	94	239	47.8	70.9	96	252	52.3	72.1	97	265	56.9	73.4	98	277	61.3	74.9	99	
2600	16.44	226	47.5	68.2	95	241	52.5	69.7	96	255	57.6	71.1	97	268	62.7	72.1	98	280	67.5	73.3	99	
2750	17.39	228	52.5	66.6	96	243	57.7	68.6	97	257	63.0	69.9	98	270	68.2	71.1	99					
2900	18.34	232	58.6	64.8	97	245	63.3	67.3	98	259	68.7	68.8	99	273	74.7	70.1	100					

- Power rating BkW does not include transmission losses.
 - The A-weighted sound ratings shown have been calculated per AMCA International Standard 301. Values shown are for inlet LwiA sound power levels for installation type B (free inlet, ducted outlet).
 - Performance certified is for installation type B: free inlet, ducted outlet. Performance ratings do not include the effects of appurtenance (accessories).

GSF-SS Version 11.0_May2024

GSF-SS series

SIROCCO FAN

www.gsfan.co.kr



GSF-13SS

FEG 75

Wheel dia	1950 mm	Tip Speed =	0.1021 * rpm	Outlet Dim'	1560 * 1980	Outlet Area	3.0888 m ²	Class 1	245 rpm	Class 2	309 rpm	Not Applicable
-----------	---------	-------------	--------------	-------------	-------------	-------------	-----------------------	---------	---------	---------	---------	----------------

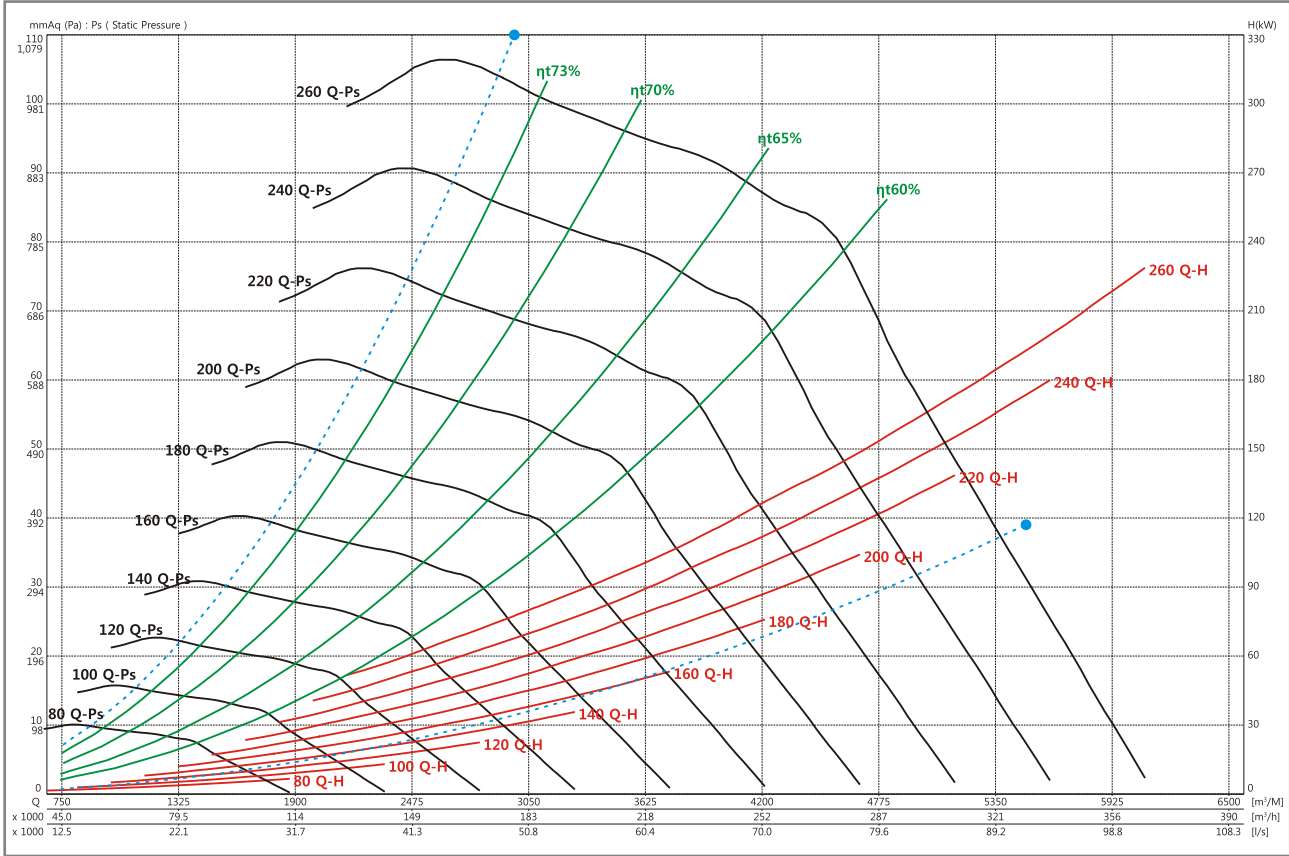

Air flow (m³/min)	Outlet Vel (m/sec)	10 mmAq (98 Pa)				20 mmAq (196 Pa)				30 mmAq (294 Pa)				40 mmAq (392 Pa)				50 mmAq (490 Pa)				
		rpm	BkW	ηt	PWL	rpm	BkW	ηt	PWL	rpm	BkW	ηt	PWL	rpm	BkW	ηt	PWL	rpm	BkW	ηt	PWL	
1200	6.48	85	3.59	69.0	71																	
1400	7.55	88	4.79	64.6	74	116	7.37	72.6	78													
1600	8.63	92	6.24	61.5	77	119	9.18	70.1	80	140	12.1	74.3	83									
1800	9.71	99	8.35	56.2	81	121	11.2	67.7	81	143	14.6	71.7	84	161	17.8	75.0	86					
2000	10.79	106	10.9	51.2	85	124	13.7	64.0	83	146	17.4	69.7	85	164	21.1	72.4	87	179	24.5	75.0	89	
2200	11.87	113	13.9	47.8	88	128	16.5	62.2	86	148	20.4	67.7	87	167	24.7	70.6	89	183	28.8	72.8	90	
2400	12.95	120	17.3	45.0	90	134	20.2	58.3	89	151	24.2	64.7	88	169	28.4	68.8	90	186	33.1	71.2	91	
2600	14.03	128	21.6	43.4	92	141	24.7	54.2	92	155	28.4	62.7	90	172	32.9	67.1	91	188	37.6	69.5	92	
2800	15.11	135	26.2	41.2	95	149	30.0	51.7	94	159	32.9	60.5	93	175	38.0	64.4	92	190	42.6	68.0	93	
3000	16.19	143	31.7	40.1	96	156	35.7	49.2	96	166	39.0	57.1	95	179	43.7	62.7	94	193	48.5	66.0	95	
3200	17.27	151	37.9	39.1	98	163	42.2	46.9	98	174	46.1	54.6	97	183	49.5	61.2	96	197	55.5	63.7	96	
3400	18.35	158	44.5	37.6	100	170	49.2	45.0	99	181	53.8	51.8	99	190	57.5	58.5	98	200	62.0	62.6	98	

Air flow (m³/min)	Outlet Vel (m/sec)	60 mmAq (588 Pa)				70 mmAq (686 Pa)				80 mmAq (785 Pa)				90 mmAq (883 Pa)				100 mmAq (981 Pa)				
		rpm	BkW	ηt	PWL	rpm	BkW	ηt	PWL	rpm	BkW	ηt	PWL	rpm	BkW	ηt	PWL	rpm	BkW	ηt	PWL	
1200	6.48																					
1400	7.55																					
1600	8.63																					
1800	9.71																					
2000	10.79																					
2200	11.87	197	32.6	75.1	92																	
2400	12.95	201	37.8	73.0	93	214	42.0	74.9	94													
2600	14.03	203	42.7	71.3	94	217	47.8	72.9	95	229	52.3	74.6	96									
2800	15.11	206	48.4	69.9	94	219	53.5	71.3	96	232	59.0	72.7	97	243	63.8	74.1	98					
3000	16.19	208	54.1	68.5	95	222	60.0	70.0	96	235	65.9	71.4	98	246	71.3	72.4	98	257	76.7	73.7	99	
3200	17.27	210	60.6	66.9	96	224	66.7	68.7	97	237	72.9	70.1	98	249	79.1	71.3	99	260	85.1	72.2	100	
3400	18.35	214	68.6	64.8	98	226	74.1	67.4	98	239	80.5	68.8	99	252	87.6	70.1	100					

- Power rating BkW does not include transmission losses.
 - The A-weighted sound ratings shown have been calculated per AMCA International Standard 301. Values shown are for inlet LwiA sound power levels for installation type B (free inlet, ducted outlet).
 - Performance certified is for installation type B: free inlet, ducted outlet. Performance ratings do not include the effects of appurtenance (accessories).

GSF-SS Version 11.0_May2024

GSF-SS series

SIROCCO FAN

www.gsfan.co.kr



GSF-14SS

FEG 75

Wheel dia	2100 mm	Tip Speed = 0.10996 * rpm	Outlet Dim'	1680 * 2135	Outlet Area	3.5868 m ²	Class 1	227 rpm	Class 2	286 rpm	Not Applicable
-----------	---------	---------------------------	-------------	-------------	-------------	-----------------------	---------	---------	---------	---------	----------------

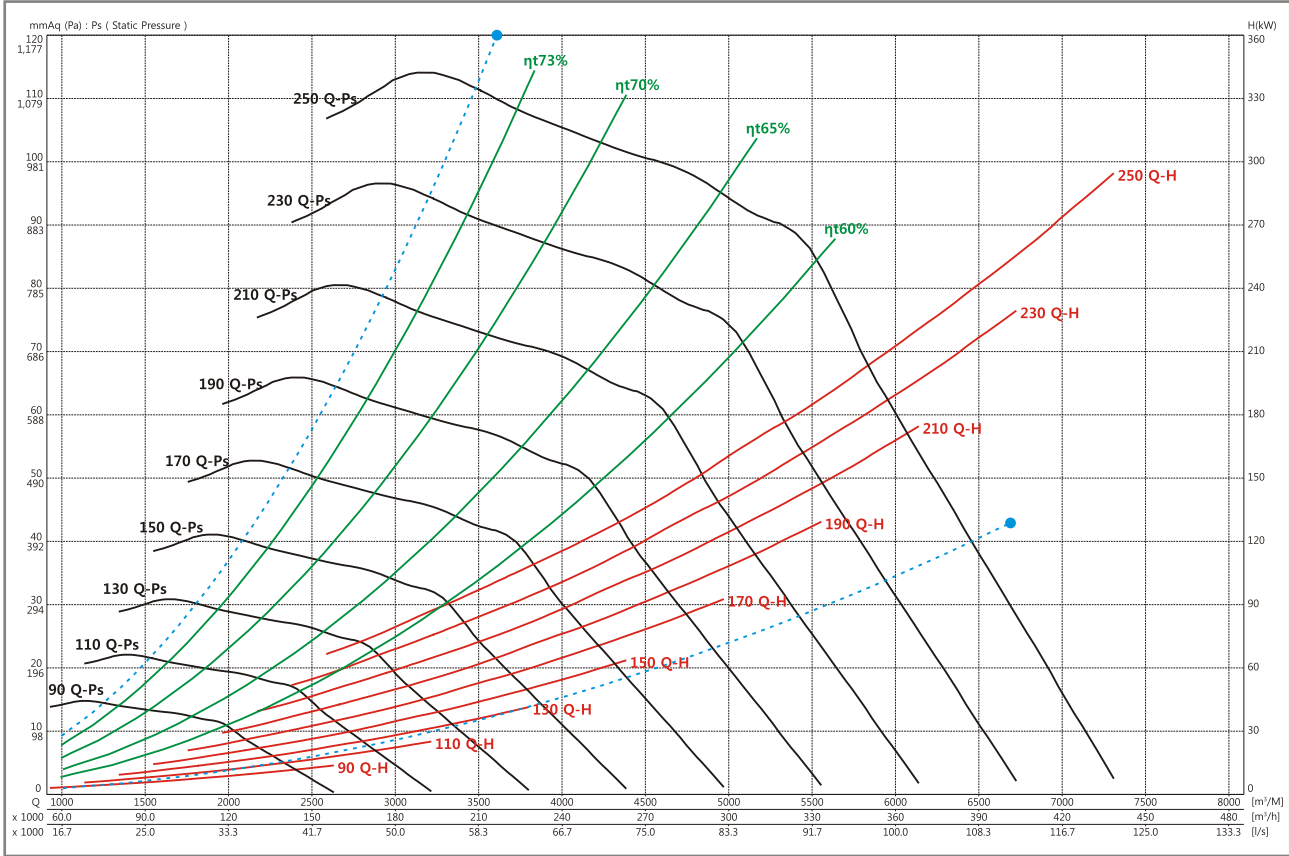

Air flow (m³/min)	Outlet Vel (m/sec)	10 mmAq (98 Pa)				20 mmAq (196 Pa)				30 mmAq (294 Pa)				40 mmAq (392 Pa)				50 mmAq (490 Pa)				
		rpm	BkW	η _t	PWL	rpm	BkW	η _t	PWL	rpm	BkW	η _t	PWL	rpm	BkW	η _t	PWL	rpm	BkW	η _t	PWL	
		m ⁻¹	kW	%	LwIA	m ⁻¹	kW	%	LwIA	m ⁻¹	kW	%	LwIA	m ⁻¹	kW	%	LwIA	m ⁻¹	kW	%	LwIA	
1700	7.90					109	9.27	71.8	79													
1900	8.83					111	11.1	69.7	80	131	14.6	73.8	83									
2100	9.76	92	9.78	55.5	82	112	13.0	67.4	82	133	17.1	71.5	84	150	21.0	74.9	87					
2300	10.69	98	12.4	51.6	85	115	15.7	64.3	83	135	19.8	69.8	86	152	24.2	72.5	88					
2500	11.62	104	15.4	49.0	87	118	18.4	62.6	86	137	22.9	68.2	87	154	27.5	71.0	89	170	32.6	73.3	90	
2700	12.55	109	18.6	45.9	90	122	21.7	59.7	88	139	26.3	65.9	88	156	31.3	69.4	89	172	36.7	71.7	91	
2900	13.48	115	22.4	44.1	92	128	26.0	56.6	91	142	30.4	63.4	90	158	35.4	68.1	91	174	41.2	70.3	92	
3100	14.40	121	26.8	42.4	93	134	30.9	53.5	93	145	34.6	62.4	91	160	39.9	66.1	92	176	46.0	69.0	93	
3300	15.33	127	31.7	40.9	95	140	36.3	51.2	95	149	39.6	59.7	94	164	45.8	64.0	93	177	50.9	67.6	94	
3500	16.26	133	37.1	39.7	97	145	41.9	48.6	97	155	46.0	57.1	95	166	50.9	62.6	95	180	57.2	65.9	95	
3700	17.19	139	43.2	38.5	98	151	48.5	47.0	98	161	53.0	54.6	97	170	57.2	61.5	96	183	64.1	63.8	96	
3900	18.12	146	50.4	38.2	100	157	55.7	45.6	99	167	60.7	52.3	99	175	64.8	58.9	98	186	71.1	62.7	97	

Air flow (m³/min)	Outlet Vel (m/sec)	60 mmAq (588 Pa)				70 mmAq (686 Pa)				80 mmAq (785 Pa)				90 mmAq (883 Pa)				100 mmAq (981 Pa)				
		rpm	BkW	η _t	PWL	rpm	BkW	η _t	PWL	rpm	BkW	η _t	PWL	rpm	BkW	η _t	PWL	rpm	BkW	η _t	PWL	
		m ⁻¹	kW	%	LwIA	m ⁻¹	kW	%	LwIA	m ⁻¹	kW	%	LwIA	m ⁻¹	kW	%	LwIA	m ⁻¹	kW	%	LwIA	
1700	7.90																					
1900	8.83																					
2100	9.76																					
2300	10.69																					
2500	11.62																					
2700	12.55	185	41.5	73.6	93																	
2900	13.48	187	46.4	72.0	93	200	52.0	73.8	95													
3100	14.40	189	51.6	70.7	94	202	57.7	72.2	95	214	63.6	73.9	96									
3300	15.33	192	57.7	69.6	95	204	63.7	71.1	96	216	70.2	72.3	97	227	76.3	73.8	98	237	82.1	75.1	99	
3500	16.26	193	63.3	68.4	96	206	70.1	69.9	97	218	76.9	71.2	98	229	83.6	72.3	99	239	89.9	73.5	100	
3700	17.19	195	70.0	67.0	97	208	77.0	68.8	98	220	84.2	70.1	98	231	91.2	71.3	99	242	98.7	72.3	100	
3900	18.12	198	77.8	65.2	98	210	84.5	67.7	98	222	91.9	69.1	99	233	99.4	70.2	100	244	107.2	71.3	101	

- Power rating BkW does not include transmission losses.
 - The A-weighted sound ratings shown have been calculated per AMCA International Standard 301. Values shown are for inlet LwIA sound power levels for installation type B (free inlet, ducted outlet).
 - Performance certified is for installation type B: free inlet, ducted outlet. Performance ratings do not include the effects of appurtenance (accessories).
 GSF-SS Version 11.0_May2024



We are challenging the global market with our technology.
www.gsfan.co.kr

(주)금성풍력

아산공장 및 본사
 HEAD OFFICE & FACTORY

충남 아산시 둔포면 아산벨리로 405번길 13
 Tel : 041-912-2500 Fax : 041-912-2555
 13, Asanbaelli-ro 405beon-gil, Dunpo-myeon, Asan-si, Chungcheongnam-do, Republic of Korea
 Tel: +82-41-912-2500 Fax: +82-41-912-2555

인천 사무소
 INCHEON BARNCH

인천광역시 남동구 청능대로 410번길 63(고잔동 남동산업단지)
 Tel : 032-811-9500 Fax : 032-811-9503
 (Gojan-dong, Namdong Ind. Complex) 63, Cheongneung-daero 410beon-gil, Namdong-gu, Incheon, Republic of Korea
 Tel: +82-32-811-9500 Fax: +82-32-811-9503





(주)금성풍력

아산공장 및 본사
HEAD OFFICE & FACTORY

충남 아산시 둔포면 아산벨리로 405번길 13

Tel : 041-912-2500 Fax : 041-912-2555

13, Asanbaelli-ro 405beon-gil, Dunpo-myeon, Asan-si, Chungcheongnam-do, Republic of Korea
Tel: +82-41-912-2500 Fax: +82-41-912-2555

인천 사무소
INCHEON BARNCH

인천광역시 남동구 청능대로 410번길 63(고잔동 남동산업단지)

Tel : 032-811-9500 Fax : 032-811-9503

(Gojan-dong, Namdong Ind. Complex) 63, Cheongneung-daero 410beon-gil, Namdong-gu, Incheon, Republic of Korea
Tel: +82-32-811-9500 Fax: +82-32-811-9503

www.gsfan.co.kr

· 본 제품의 사양은 품질개선을 위하여 예고없이 변경될 수 있습니다.
· Due to a policy of continuous development and improvement the right is reserved to supply products which may differ from those illustrated and described in this publication.
Certified dimensions will be supplied on receipt of order.

· 당사와의 협의없이 본 내용을 복제시 법의 저촉을 받습니다.
· Be under the application of a law if you copy those illustrated and described in this publication which is not conferred with us.