

MODEL EA-475-DH

Severe Weather Louver • 4" Deep • Chevron Blades • Stationary • Horizontal • Extruded Aluminum

Standard Materials and Construction

FRAME: .081" thk. (nominal) extruded aluminum, 6063-T52/T6 alloy.

BLADE: .081" thk. (nominal) extruded aluminum, 6063-T52/T6 alloy.
Blades approximately 1 $\frac{5}{8}$ " on centers.

LOUVER FACE: Blades are contained within jambs, sill contains jambs, and head is flush with jambs.

SCREENS: (When indicated, in a removable frame.)

- 1/2" flattened aluminum (.051" thick),
- or- 1/2" sq. mesh, intermediate double-crimped aluminum wire, .063" dia.,
- or- 1 $\frac{3}{16}$ " mesh, .011" dia. aluminum wire, insect screen.

DRAIN SILL PAN: .060" thick (nominal) formed aluminum.

FINISH: Mill

Options

Finish - Baked Enamel, Kynar, Anodize

Notes

- Nominal deductions will be made to the opening size given.
- Approximate shipping weight is 5.5 lbs./sq.ft.

Louver Sizes

| Min Panel | Max Single Panel |
|-------------|------------------|
| 12"W x 12"H | 60"W x 96"H |

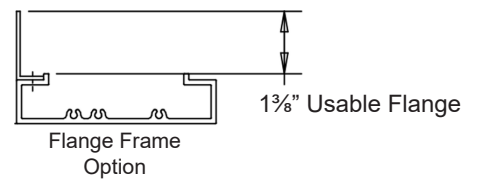
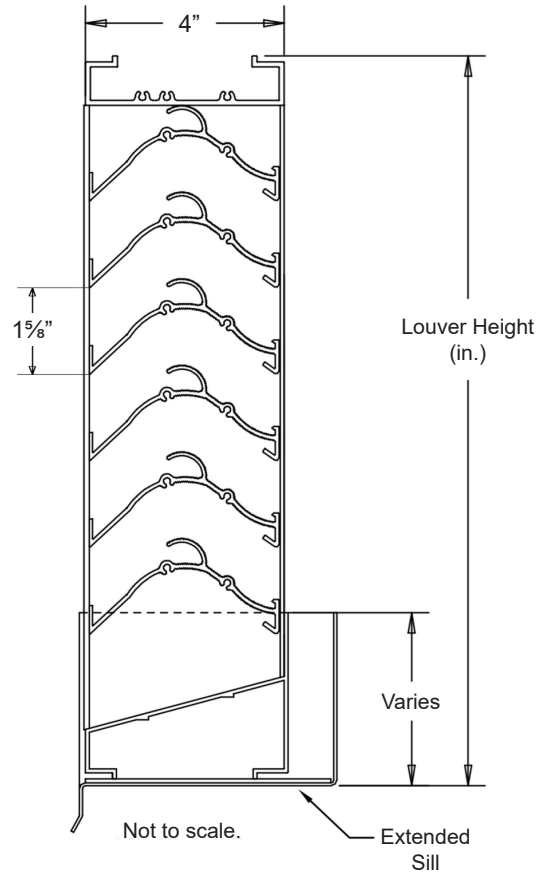
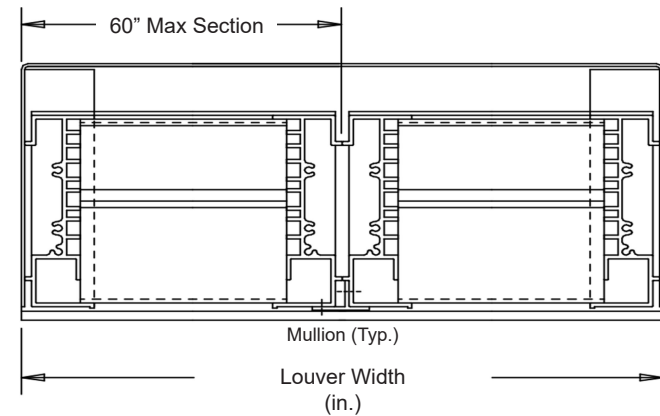

| Item # | Qty | Width | Height | Width | Height | Mullion | Type | Location | Union Made |
|---------------|-----|--------------|--------|-------------|--------|---------|---------|----------|------------|
| | | Opening Size | | Louver Size | | | Screens | | |
| Arch. / Eng.: | | | | | | EDR: | | ECN: | Job: |
| Contractor: | | | | | | | | | |
| Project: | | | | | | Date: | | DWN: | DWG: |



MODEL EA-475-DH

Severe Weather Louver • 4" Deep • Chevron Blades • Stationary • Horizontal • Extruded Aluminum

Performance Data

Pressure Drop: .260 in. w.g. at 1000 fpm (intake)

Free Area: 7.50 sq.ft. = 47% for 48"W x 48"H sample tested in accordance with AMCA Standard 500-L.

Class "A" Rating with 99% efficiency at 3 in. rain fall at intake velocity of 1302 fpm (7,174 cfm) at wind speed of 29 mph.

Class "B" Rating with 95.8% efficiency at 8 in. rain fall at intake velocity of 1102 fpm (6,071 cfm) at wind speed of 50 mph.

Testing based on 48" x 48" based on AMCA Standard 500-L.

Ratings do not include effects of a screen.

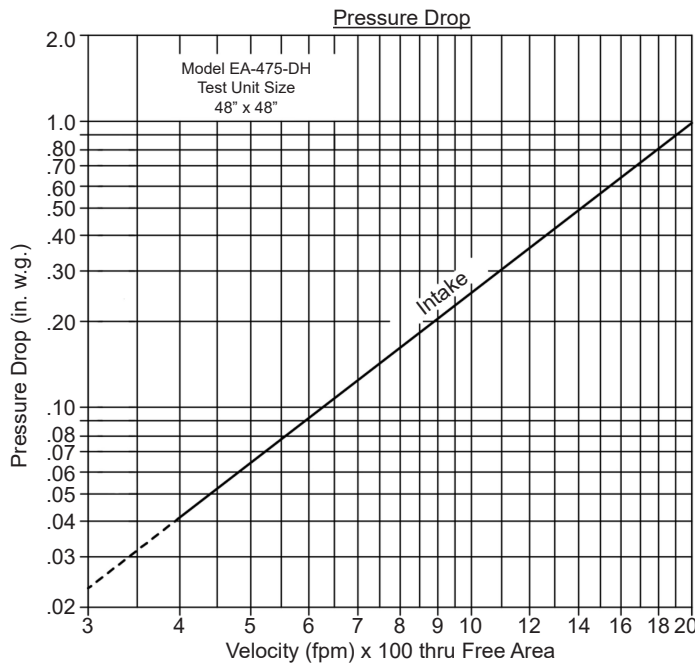

Intake air converted to standard air density.
Tested to AMCA Standard 500-L, Figure 5.5.

| | | Free Area (sq. ft.) | | | | | | | | |
|--------------|-----|---------------------|------|------|-------|-------|-------|-------|-------|-------|
| | | Width (in.) | | | | | | | | |
| | | 12" | 18" | 24" | 30" | 36" | 42" | 48" | 54" | 60" |
| Height (in.) | 12" | .20 | .33 | .46 | .59 | .72 | .85 | .98 | 1.11 | 1.24 |
| | 24" | .73 | 1.19 | 1.66 | 2.12 | 2.59 | 3.05 | 3.52 | 3.98 | 4.45 |
| | 36" | 1.19 | 1.94 | 2.70 | 3.46 | 4.22 | 4.98 | 5.74 | 6.50 | 7.26 |
| | 48" | 1.71 | 2.80 | 3.90 | 4.99 | 6.09 | 7.18 | 7.50 | 9.37 | 10.46 |
| | 60" | 2.17 | 3.56 | 4.95 | 6.33 | 7.72 | 9.11 | 10.50 | 11.89 | 13.27 |
| | 72" | 2.63 | 4.31 | 5.99 | 7.67 | 9.36 | 11.04 | 12.72 | 14.40 | 16.08 |
| | 84" | 3.15 | 5.17 | 7.19 | 9.21 | 11.22 | 13.24 | 15.26 | 17.27 | 19.29 |
| | 96" | 3.61 | 5.92 | 8.23 | 10.55 | 12.86 | 15.17 | 17.48 | 19.79 | 22.10 |

MODEL EA-475-DH

Severe Weather Louver • 4" Deep • Chevron Blades • Stationary • Horizontal • Extruded Aluminum

Wind Driven Rain

Wind Driven Rainwater Penetration Test
 Conducted to AMCA Standard 500-L.

Test size 1m x 1m (39.7" x 39.7") core area, nominal.
 Louver Free Area 5.51 square feet.

| Core Ventilation (m/s) | 0.0 | 0.5 | 1.0 | 1.5 | 2.0 | 2.5 | 3.0 | 3.5 | Rain Fall / MPH |
|-----------------------------|-----|-------|-------|-------|-------|-------|-------|-------|---|
| FPM | 0 | 98 | 197 | 295 | 394 | 492 | 578 | 666 | 3 in. / hr. rain fall and 29 mph Velocity |
| Free Area Ventilation (cfm) | - | - | - | - | - | 5,302 | 6,220 | 7,174 | |
| Free Area Velocity (fpm) | - | - | - | - | - | 962 | 1,129 | 1,302 | |
| Effective Rating Class | A | A | A | A | A | A | A | A | 8 in. / hr. rain fall and 50 mph Velocity |
| FPM | 0 | 102 | 198 | 282 | 381 | 468 | 564 | 690 | |
| Free Area Ventilation (cfm) | 0 | 1,100 | 2,129 | 3,041 | 4,105 | 5,041 | 6,071 | 7,433 | |
| Free Area Velocity (fpm) | 0 | 200 | 386 | 552 | 745 | 915 | 1,102 | 1,349 | |
| Effective Rating Class | B | B | B | B | B | B | B | C | |

Wind Driven Rain Penetration Classifications

| Class | Effectiveness % |
|-------|-----------------|
| A | 100 to 99% |
| B | 98.9% to 95% |
| C | 94.9% to 80% |
| D | Below 80% |

Discharge Loss Coefficient Classifications

| Class | Discharge Loss Coefficient |
|-------|----------------------------|
| 1 | 0.4 and above |
| 2 | 0.3 to 0.399 |
| 3 | 0.2 to 0.299 |
| 4 | 0.199 and below |

Discharge Coefficient
 Intake Cd= 0.25 (Class 3)

Class 1 Loss Coefficient has the least resistance to airflow.

1. Core area is the front opening of a louver assembly with the blades removed.
2. Core area velocity is the airflow rate through the louver divided by the core area (39.37" x 39.37").
3. Free area is the minimum area through which air can pass. It is determined by multiplying the sum of the minimum distance between intermediate blades, top blade and head, bottom blade and sill, by the minimum distance between jambs.
4. Discharge loss coefficient is calculated by dividing a louver actual airflow rate vs. a theoretical airflow for the opening, providing an indication of the louver air flow characteristics.



Arrow United Industries certifies that the Model EA-475-DH shown herein is licensed to bear the AMCA seal. The ratings shown are based on tests and procedures performed in accordance with AMCA Publication 511 and comply with the requirements of the AMCA Certified Ratings Program. The AMCA Certified Ratings Seal applies to Air Performance and Wind Driven Rain Ratings only.