

**Smoke Damper**

**Steel Airfoil Blades**

**UL 555S Leakage Class I**

## Application

The SMD-301 is a leakage rated smoke damper with airfoil blades for operational closure in emergency smoke control situations. The SMD-301 may be installed vertically (with blades running horizontal) or horizontally and is rated for airflow and leakage in either direction.

## Ratings

**Leakage Class:** I

### Operational Rating

**Maximum Velocity:** 4,000 fpm (20.3 m/s)

**Maximum Pressure:** 8 in. wg (2 kPa)

**Maximum Temperature:** 350°F (177°C)



\*W & H dimensions furnished approximately 1/4 in. (6mm) undersize in case of nominal sizing only. Add sleeve thickness for overall sleeved damper dimension. Right hand drive is shown. Left hand drive is available.

Construction	Standard	Optional
<b>Frame Material</b>	Galvanized Steel	-
<b>Frame Material Thickness</b>	16 ga. (1.5mm)	-
<b>Frame Type</b>	5 in. x 1 in. (127mm x 25mm) hat channel	-
<b>Blade Material</b>	Galvanized Steel	-
<b>Blade Material Thickness</b>	14 ga. (2mm) Equivalent	-
<b>Blade Type</b>	Double Skin Airfoil	-
<b>Linkage</b>	Plated Steel Out of Airstream, Concealed in Jamb	316SS
<b>Axle Bearings</b>	316SS	-
<b>Axle Material</b>	Plated Steel	316SS
<b>Blade Seals</b>	Silicone	-
<b>Jamb Seals</b>	Stainless Steel	-

Model SMD-301 meets the requirements for smoke dampers established by:

**National Fire Protection Association**

NFPA Standards 92, 101, & 105

**International Building Codes (IBC)**



See complete marking on product.

UL 555S Classification  
R13317

## Size Limitations

W x H	Minimum Size	Maximum Size*	
		Single Section	Multiple Section
Inches	8 x 6	32 x 50	192 x 100
mm	203 x 152	813 x 1270	4877 x 2540

**Note:** Maximum sizes are dependent on velocities and pressures.

## Features

- Frames are constructed with reinforced corners. Low profile head and sill are used on sizes less than 17 in. (432mm) high
- Blades are double skin airfoil shape of galvanized steel with full length structural reinforcement
- Actuators: 24V, 230V

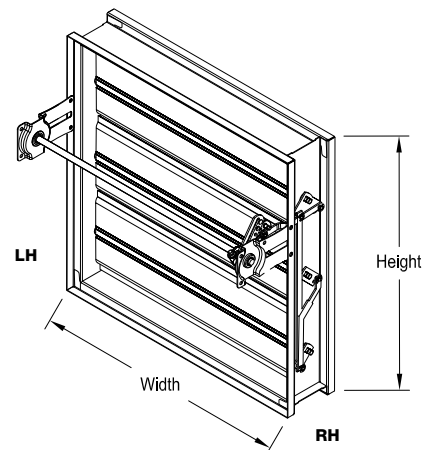

**Options for SMD-301:**

- Factory mounted accessories:
  - TDF Flange
  - Quick Connect breakaway connections
  - POC Retaining angles
  - S & Drive connections
- OCI (Open Closed Indication Switches)
- Transitions: R

**Pressure Drop Data**

This pressure drop testing was conducted in accordance with AMCA Standard 500-D using the three configurations shown. All data has been corrected to represent standard air at a density of .075 lb/ft<sup>3</sup> (1.201 kg/m<sup>3</sup>).

Actual pressure drop found in any HVAC system is a combination of many factors. This pressure drop information along with an analysis of other system influences should be used to estimate actual pressure losses for a damper installed in a given HVAC system.

**AMCA Test Figures**

**Figure 5.3** Illustrates a fully ducted damper. This configuration has the lowest pressure drop of the three test configurations because entrance and exit losses are minimized by straight duct runs upstream and downstream of the damper.

**Figure 5.2** Illustrates a ducted damper exhausting air into an open area. This configuration has a lower pressure drop than Figure 5.5 because entrance losses are minimized by a straight duct run upstream of the damper.

**Figure 5.5** Illustrates a plenum mounted damper. This configuration has the highest pressure drop because of extremely high entrance and exit losses due to the sudden changes of area in the system.

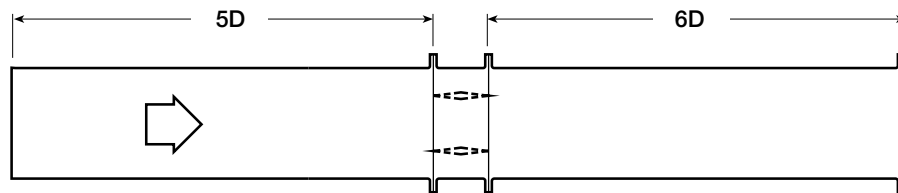

Figure 5.3

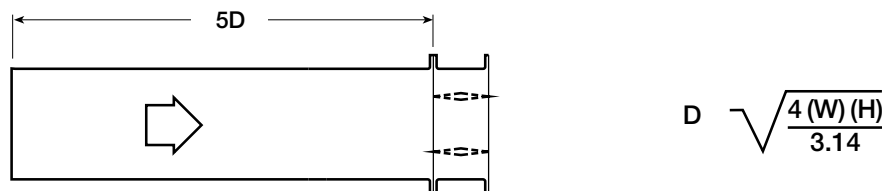

Figure 5.2

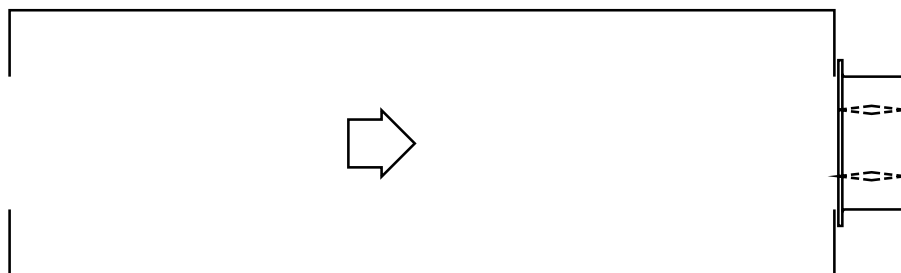
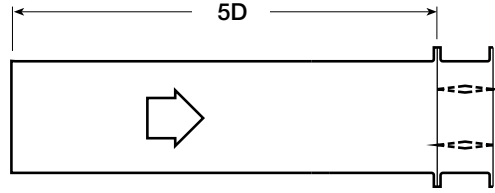

Figure 5.5

# Pressure Drop Data

# SMD-301

**AMCA Figure 5.2**



12 in. x 12 in. (305mm x 305mm)

Velocity (fpm)	Pressure Drop (in. wg)
500	0.03
1000	0.11
1500	0.24
2000	0.42
2500	0.66
3000	0.95
3500	1.30
4000	1.70

24 in. x 24 in. (610mm x 610mm)

Velocity (fpm)	Pressure Drop (in. wg)
500	0.01
1000	0.06
1500	0.12
2000	0.22
2500	0.34
3000	0.49
3500	0.67
4000	0.87

36 in. x 36 in. (914mm x 914mm)

Velocity (fpm)	Pressure Drop (in. wg)
500	0.01
1000	0.05
1500	0.12
2000	0.21
2500	0.32
3000	0.47
3500	0.63
4000	0.83

12 in. X 48 in. (305mm x 1219mm)

Velocity (fpm)	Pressure Drop (in. wg)
500	0.01
1000	0.05
1500	0.12
2000	0.21
2500	0.33
3000	0.48
3500	0.65
4000	0.85

48 in. x 12 in. (1219mm x 305mm)

Velocity (fpm)	Pressure Drop (in. wg)
500	0.02
1000	0.08
1500	0.18
2000	0.33
2500	0.51
3000	0.74
3500	1.00
4000	1.31

**AMCA Figure 5.3**

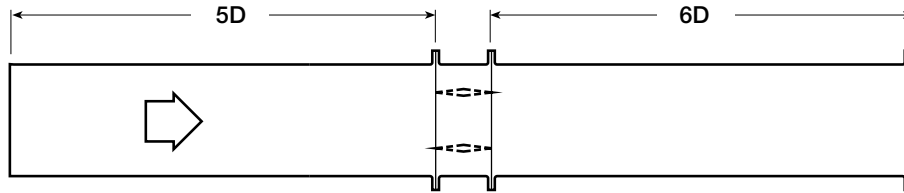

12 in. x 12 in. (305mm x 305mm)

Velocity (fpm)	Pressure Drop (in. wg)
500	0.01
1000	0.06
1500	0.13
2000	0.23
2500	0.37
3000	0.53
3500	0.73
4000	0.95

24 in. x 24 in. (610mm x 610mm)

Velocity (fpm)	Pressure Drop (in. wg)
500	0.01
1000	0.02
1500	0.06
2000	0.10
2500	0.16
3000	0.23
3500	0.32
4000	0.42

36 in. x 36 in. (914mm x 914mm)

Velocity (fpm)	Pressure Drop (in. wg)
500	0.01
1000	0.02
1500	0.05
2000	0.09
2500	0.14
3000	0.21
3500	0.29
4000	0.38

12 in. X 48 in. (305mm x 1219mm)

Velocity (fpm)	Pressure Drop (in. wg)
500	0.01
1000	0.03
1500	0.06
2000	0.11
2500	0.18
3000	0.25
3500	0.34
4000	0.45

48 in. x 12 in. (1219mm x 305mm)

Velocity (fpm)	Pressure Drop (in. wg)
500	0.01
1000	0.04
1500	0.10
2000	0.18
2500	0.29
3000	0.42
3500	0.57
4000	0.74

**AMCA Figure 5.5**

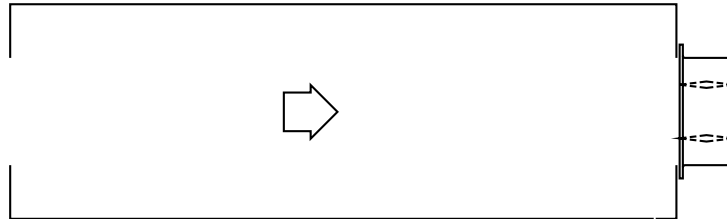

12 in. x 12 in. (305mm x 305mm)

Velocity (fpm)	Pressure Drop (in. wg)
500	0.04
1000	0.18
1500	0.42
2000	0.75
2500	1.17
3000	1.68
3500	2.29
4000	2.09

24 in. x 24 in. (610mm x 610mm)

Velocity (fpm)	Pressure Drop (in. wg)
500	0.03
1000	0.13
1500	0.29
2000	0.52
2500	0.81
3000	1.17
3500	1.60
4000	2.14

36 in. x 36 in. (914mm x 914mm)

Velocity (fpm)	Pressure Drop (in. wg)
500	0.03
1000	0.12
1500	0.27
2000	0.48
2500	0.75
3000	1.08
3500	1.48
4000	1.93

12 in. X 48 in. (305mm x 1219mm)

Velocity (fpm)	Pressure Drop (in. wg)
500	0.03
1000	0.12
1500	0.27
2000	0.49
2500	0.77
3000	1.11
3500	1.51
4000	1.97

48 in. x 12 in. (1219mm x 305mm)

Velocity (fpm)	Pressure Drop (in. wg)
500	0.03
1000	0.14
1500	0.32
2000	0.57
2500	0.89
3000	1.28
3500	1.75
4000	2.29



Greenheck India Private Limited certifies that the model SMD-301 shown herein is licensed to bear the AMCA Seal. The ratings shown are based on tests and procedures performed in accordance with AMCA Publication 511 and comply with the requirements of the AMCA Certified Ratings Programs. The AMCA Certified Ratings Seal applies to air performance ratings only.

## Space Envelopes Required for Actuators and Accessories

Externally mounted actuators always require space outside of the damper sideplate or sleeve. The “S” dimension illustrates the clearance required for various available actuators.

On dampers less than 18 in. (457mm) high, actuators may also require clearances above and/or below the sideplate or sleeve. “B” and “T” dimensions are worst case clearance requirements for some dampers less than 18 in. (457mm) high. All damper sizes under 18 in. (457mm) high do not require these worst case clearances. If space availability above or below the damper sleeve is limited, each damper size should be individually evaluated.

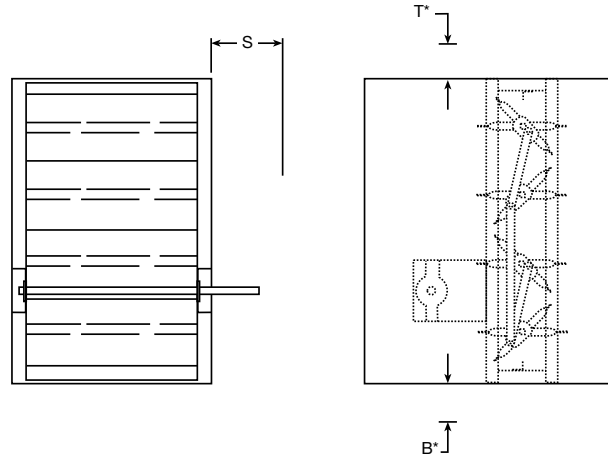

Actuator Type/Model	B*	T*	S	
	With RRL, RRL/OCI	With RRL, RRL/OCI	Piggyback	
			No	Yes
<b>24 Volt AC</b>				
FSAF24 (-S) Belimo	½ in. (13mm)	9 <sup>13</sup> / <sub>16</sub> in (249mm)	6 in. (152mm)	NA
FSTF24 (-S) Belimo	7 <sup>11</sup> / <sub>16</sub> in (195mm)	½ in. (13mm)	6 in. (152mm)	NA
FSLF24 (-S) Belimo	7 <sup>11</sup> / <sub>16</sub> in (195mm)	0	6 in. (152mm)	NA
FSNF24 (-S) Belimo	½ in. (13mm)	9 <sup>13</sup> / <sub>16</sub> in (249mm)	6 in. (152mm)	9 in. (229mm)
MS8X09 Series Honeywell	½ in. (13mm)	8½ in (216mm)	6 in. (152mm)	NA
MS8120 Series Honeywell	½ in. (13mm)	9 <sup>13</sup> / <sub>16</sub> in (249mm)	6 in. (152mm)	9 in. (229mm)
<b>230 Volt AC</b>				
FSLF230 (-S) Belimo	7 <sup>11</sup> / <sub>16</sub> in (195mm)	0	6 in. (152mm)	NA
FSNF230 (-S) Belimo	½ in. (13mm)	9 <sup>13</sup> / <sub>16</sub> in (249mm)	6 in. (152mm)	9 in. (229mm)
FSTF230 (-S) Belimo	7 <sup>11</sup> / <sub>16</sub> in (195mm)	½ in. (13mm)	6 in. (152mm)	NA
MS4X09 Series Honeywell	½ in. (13mm)	8½ in (216mm)	6 in. (152mm)	NA
MS4620 Series Honeywell	½ in. (13mm)	9 <sup>13</sup> / <sub>16</sub> in (249mm)	6 in. (152mm)	9 in. (229mm)

\* For dampers 18 in. (457mm) or more in height these dimensions are 0 in. (0mm)

## Damper Sideplate and Sleeve Dimensional Data

The drawings illustrate the factory standard sideplate and sleeve mountings for the SMD-301. The standard "A" dimensions listed in the table provide adequate space for the mounting of actuators and controls.

If space constraints are a problem the "A" dimension can be varied between 6 in. (152mm) and 16 in. (406mm).

in. (mm)	"A" Dimension		
	Sleeve		Sideplate
	Standard	Maximum	
All Dampers	7 <sup>3</sup> / <sub>16</sub> (183)	16 (406)	6 <sup>3</sup> / <sub>16</sub> (157)
When height is 11 in. (279) or less with OCI	12 (305)	16 (406)	12 (305)

**NOTE:** Entire damper frame is not required to be installed within the wall. The damper blades, when closed should be contained within the wall.

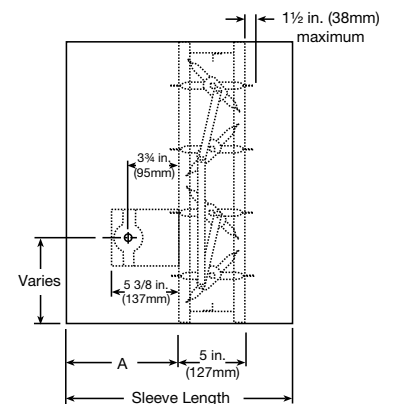
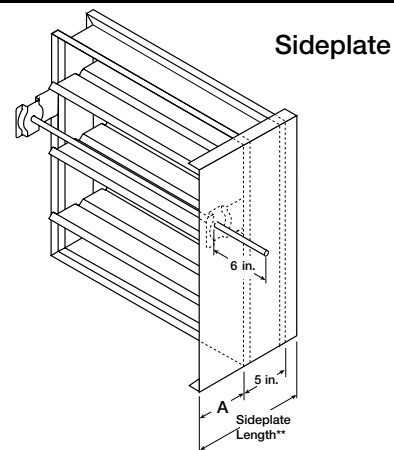

Sleeve

## Damper Sizing Information

Dampers larger than maximum single section size are supplied as a factory assembly of two or more sections of equal size. The following figures show damper sections and assemblies that have been qualified for operation with a single actuator. Larger size can be accommodated using multiples of these assemblies.

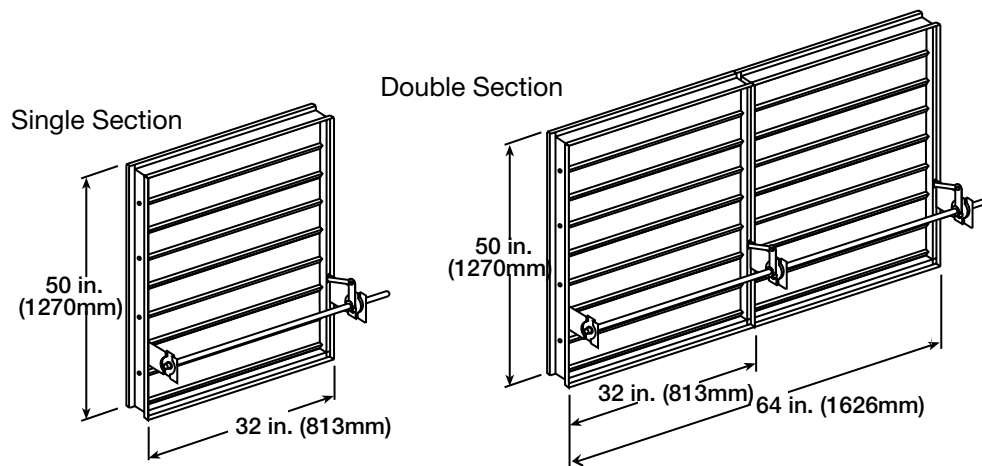

## Transitioned Damper Dimensions

When a smoke damper is being used in conjunction with round or oval ductwork, the SMD-301 can be supplied in a factory sleeve with round or oval transitions on both ends of the sleeve. Dampers should be ordered to the duct dimensions. Drawing below shows overall damper size.

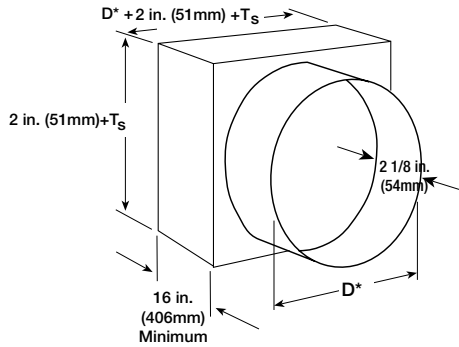

TYPE R

\*These dimensions are furnished approximately 1/4 in. (6mm) undersize, except round and oval dimensions which are approximately 1/8 in. (3mm) undersize.

$T_s = (2)(\text{Sleeve Thickness})$

## Specifications

Smoke dampers meeting the following specifications shall be furnished and installed where shown on plans and/or as described in schedules. Dampers shall meet the requirements of NFPA 92, 101, and 105 and further shall be tested, rated and labeled in accordance with the latest edition of UL Standard 555S. Smoke dampers shall be of low leakage design qualified to UL 555S Leakage Class I.

Each damper/actuator combination shall have a UL 555S elevated temperature rating of 250°F (121°C) minimum and shall be operational at maximum design air flow at its installed location. Each damper shall be supplied with an appropriate actuator installed by the damper manufacturer at the time of damper fabrication. Damper actuator shall be (specifier select one of the following) electric type for 24 or 230 volt operation.

Damper blades shall be of the double skin airfoil type and shall have an equivalent metal thickness of 14 ga. (2mm). Damper frame shall be galvanized steel formed into a structural hat channel shape with reinforced corners. Bearings shall be 316SS rotating in extruded holes in the damper frame. Blade edge seals shall be silicone rubber designed to inflate and provide a tighter seal against leakage as pressure on either side of the damper increases. Jamb seals shall be stainless steel compression type. Blades shall be completely symmetrical relative to their axle pivot point, presenting identical resistance to airflow in either direction or pressure on either side of the damper.

Damper must be rated for mounting vertically (with blades running horizontal) or horizontally and be UL 555S rated for leakage and airflow in either direction through the damper.

The basis of design is Greenheck Model SMD-301.

