

T9208

Stationary Louver | Airfoil Blade | Extruded Aluminum

Standard Construction

Frame	Heavy gauge formed aluminum, 8 in. (203 mm) x 0.080 in. (2 mm) nominal wall thickness
Blades	Airfoil style, heavy gauge formed aluminum, 0.080 in. (2 mm) nominal wall thickness, positioned 45° on approximately 6 in. (152 mm) centers
Louver Depth	8 in. (203 mm)
Construction	Mechanically fastened
Finish	Mill
Acoustical Insulation	Fiberglass Insulation
Minimum Size	12 in. W x 16.5 in. H (305 mm W x 419 mm H)
Maximum Single Section Size	60 in. W x 120 in. H (1524 mm W x 3048 mm H)
Wind Load	25 PSF (1.2 kPa)

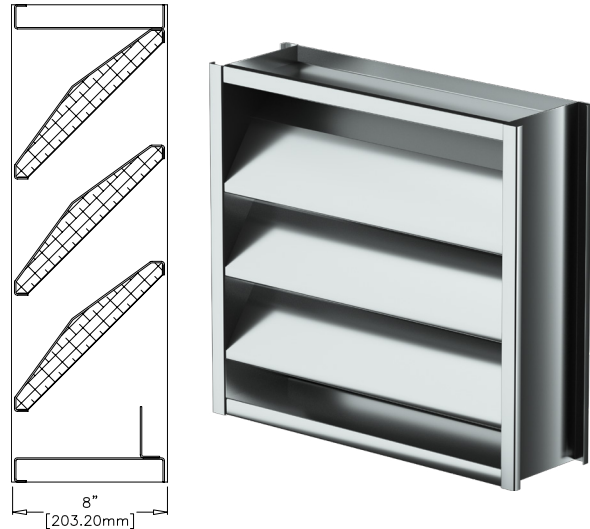

Performance Ratings



Airolite certifies that the T9208 louvers shown herein are licensed to bear the AMCA Seal. The ratings shown are based on tests and procedures performed in accordance with AMCA Publication 511 and comply with the requirements of the AMCA Certified Ratings Program. The AMCA Certified Ratings Seal applies to Water Penetration, Sound and Air Performance ratings.

Louvers were tested in accordance with the AMCA standard 500-L.

Performance of 48 in. x 48 in. (1219 mm x 1219 mm) Louver

Free Area	
Area	5.21 sq. ft. (0.484 sq. m)
Percent	32.6 %
Performance at Beginning Point of Water Penetration	
Free Area Velocity	879 fpm (4.465 m/s)
Max Intake Volume	4580 cfm (2.161 m ³ /s)
Performance at 6,000 CFM (2.832 m³/s) Intake	
Pressure Drop	0.085 in. wg (0.021 kPa)

Document Links

[Architectural Louvers Catalog](#)

[Finishes & Colors](#)

[Qwik Ship Guide](#)

[Airolite Warranty Statement](#)

Options and Accessories

- [Bird Screen](#)
- [Blank Off Panels](#)
- [Extended Sill](#)
- [Filter Rack/Filter](#)
- [Flange Frame](#)
- Galvanized or Galvaneal Frame and Blade
- [Insect Screen](#)
- [Mounting Angles](#)
- [Security Bars](#)
- [Variety of Architectural Finishes](#)
- Welded Construction

Standard Details

[T9208 Standard Details](#)

Structural reinforcing members may be required to adequately support and install multiple louver sections within a large opening. Structural reinforcing members along with any associated installation hardware is not provided by Airolite unless indicated otherwise by Airolite. Options and accessories including, but not limited to, screens, filter racks, louver doors, and blank off panels are not subject to structural analysis unless indicated otherwise by Airolite.

 **AIROLITE**[®]
The look that works.[™]

T9208

Stationary Louver | Airfoil Blade | Extruded Aluminum

Free Area Chart

Free Area Chart shows free area in square feet and square meters.

Louver Height Inches (Meters)	Louver Width in Inches (Meters)								
	12	18	24	30	36	42	48	54	60
0.30	0.46	0.61	0.76	0.91	1.07	1.22	1.37	1.52	
16.5	0.16	0.27	0.37	0.48	0.58	0.69	0.79	0.89	1.00
0.42	0.01	0.03	0.03	0.04	0.05	0.06	0.07	0.08	0.09
18	0.26	0.42	0.59	0.76	0.93	1.09	1.26	1.43	1.59
0.46	0.02	0.04	0.05	0.07	0.09	0.10	0.12	0.13	0.15
24	0.42	0.69	0.96	1.23	1.51	1.78	2.05	2.32	2.59
0.61	0.04	0.06	0.09	0.11	0.14	0.17	0.19	0.22	0.24
30	0.58	0.96	1.33	1.71	2.09	2.46	2.84	3.22	3.59
0.76	0.05	0.09	0.12	0.16	0.19	0.23	0.26	0.30	0.33
36	0.74	1.22	1.70	2.19	2.67	3.15	3.63	4.11	4.59
0.91	0.07	0.11	0.16	0.20	0.25	0.29	0.34	0.38	0.43
42	0.90	1.49	2.08	2.66	3.25	3.83	4.42	5.01	5.59
1.07	0.08	0.14	0.19	0.25	0.30	0.36	0.41	0.47	0.52
48	1.07	1.76	2.45	3.14	3.83	4.52	5.21	5.90	6.59
1.22	0.10	0.16	0.23	0.29	0.36	0.42	0.48	0.55	0.61
54	1.23	2.02	2.82	3.61	4.41	5.20	6.00	6.80	7.59
1.37	0.11	0.19	0.26	0.34	0.41	0.48	0.56	0.63	0.71
60	1.39	2.29	3.19	4.09	4.99	5.89	6.79	7.69	8.59
1.52	0.13	0.21	0.30	0.38	0.46	0.55	0.63	0.71	0.80
66	1.55	2.55	3.56	4.56	5.57	6.58	7.58	8.59	9.59
1.68	0.14	0.24	0.33	0.42	0.52	0.61	0.70	0.80	0.89
72	1.71	2.82	3.93	5.04	6.15	7.26	8.37	9.48	10.59
1.83	0.16	0.26	0.37	0.47	0.57	0.67	0.78	0.88	0.98
78	1.87	3.09	4.30	5.52	6.73	7.95	9.16	10.38	11.59
1.98	0.17	0.29	0.40	0.51	0.63	0.74	0.85	0.96	1.08
84	2.03	3.35	4.67	5.99	7.31	8.63	9.95	11.27	12.59
2.13	0.19	0.31	0.43	0.56	0.68	0.80	0.92	1.05	1.17
90	2.20	3.62	5.04	6.47	7.89	9.32	10.74	12.16	13.59
2.29	0.20	0.34	0.47	0.60	0.73	0.87	1.00	1.13	1.26
96	2.36	3.89	5.41	6.94	8.47	10.00	11.53	13.06	14.59
2.44	0.22	0.36	0.50	0.64	0.79	0.93	1.07	1.21	1.36
102	2.52	4.15	5.79	7.42	9.05	10.69	12.32	13.95	15.59
2.59	0.23	0.39	0.54	0.69	0.84	0.99	1.14	1.30	1.45
108	2.68	4.42	6.16	7.90	9.63	11.37	13.11	14.85	16.59
2.74	0.25	0.41	0.57	0.73	0.89	1.06	1.22	1.38	1.54
114	2.84	4.68	6.53	8.37	10.21	12.06	13.90	15.74	17.59
2.90	0.26	0.43	0.61	0.78	0.95	1.12	1.29	1.46	1.63
120	3.00	4.95	6.90	8.85	10.79	12.74	14.69	16.64	18.59
3.05	0.28	0.46	0.64	0.82	1.00	1.18	1.36	1.55	1.73

Sound Transmission Class

The Sound Transmission Class (STC) is a rating of the effectiveness of an assembly in isolating or reducing airborne sound transmission. STC is a single number that summarizes airborne sound transmission loss data. Assemblies with higher STC ratings are more efficient at reducing sound transmission. STC is determined in accordance with ASTM E413-04.

Transmission Loss

Transmission loss (TL) is a measurement of the reduction of sound power transmission (dB) through an assembly at a given frequency. The more sound power that is reduced, the greater the TL. TL is tested in accordance with ASTM E90-04.

Free Field Noise Reduction in Decibels

Free Field Noise Reduction is determined by adding 6 dB to the Transmission Loss.

Octave Band	2	3	4	5	6	7	STC
Frequency (Hz)	125	250	500	1000	2000	4000	8
Transmission Loss (dB)	4	2	4	8	14	9	
Free Field Noise Reduction (dB)	10	8	10	14	20	15	



T9208

Stationary Louver | Airfoil Blade | Extruded Aluminum

Airflow Resistance

Standard Air - 0.075 lb/ft³ (1.2 kg/m)

Test size 48 in. x 48 in. (1219 mm x 1219 mm)

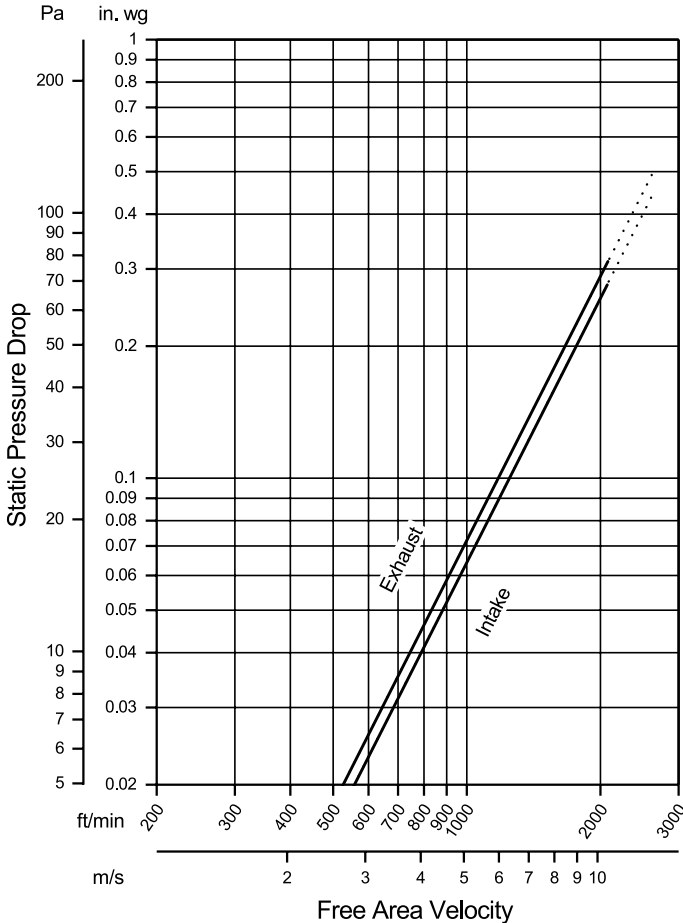

Model T9208 resistance to airflow (pressure drop) varies depending on louver application (air intake or air exhaust). Free area velocities (shown) are higher than average velocity through the overall louver size. See louver selection information. (Test Figure 5.5-6.5)

Water Penetration

Standard Air - 0.075 lb/ft³ (1.2 kg/m)

Test size 48 in. x 48 in. (1219 mm x 1219 mm)

Test duration of 15 min.

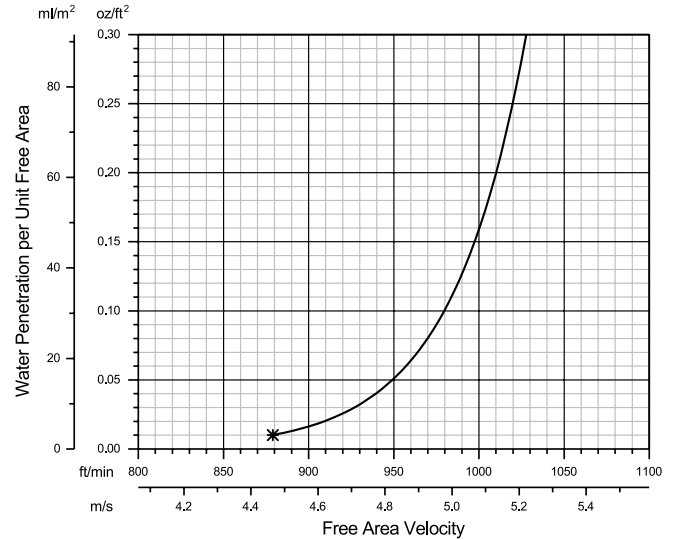

The AMCA Water Penetration Test provides a method for comparing various louver models and designs as to their efficiency in resisting the penetration of rainfall under specific laboratory test conditions. The beginning point of water penetration is defined as that velocity where the water penetration curve projects through 0.01 oz. (3 g) of water (penetration) per sq. ft. (m²) of louver free area. ***The beginning point of water penetration for Model T9208 is 879 fpm (4.465 m/s) free area velocity.** These performance ratings do not guarantee a louver to be weatherproof or stormproof and should be used in combination with other factors including good engineering judgement in selecting louvers.

