

Application

The ICD-45 is a low leakage thermally insulated damper with extruded airfoil blades. ICD-45 features thermally broken frame and blade will minimize the transfer of thermal energy and reduces condensation. It's also IECC (International Energy Conservation Code) compliant with a leakage rating of 3 cfm/ft² @ 1 in. wg (55 cmh/m² @ .25 kPa) or less.

The new quick connect frame allows easy connection to ductwork.

Note Regarding UV Lights:

The dampers should not be mounted or stored in direct line of sight to UV lights.

Ratings

Pressure

Up to 8 in. wg (2kPa) pressure differential

Velocity

2,500 to 4,000 fpm (12.7 m/s - 20.3 m/s)

Leakage

Class 1A @ 1 in. wg at -40°F (Class 1A @ .25 kPa at -40°C)
Class 1 @ 4 in. wg at -40°F (Class 1 @ 4 in. wg at -40°C)

Temperature

-70°F to 200°F (-56°C to 93°C)

Construction

	Standard	Optional
Frame Material	Aluminum, thermally broken (6063T5)	
Frame Thickness	.125 in. (3.2mm)	
Frame Type	5 in. x 1 in. (127mm x 25mm) Quick Connect	Single Flange, Reverse Flange, Channel
Blade Action	Opposed	Parallel
Blade Material	Extruded Aluminum (6063T5)	
Blade Type	Insulated Thermally Broken Airfoil	
Linkage	Plated Steel Out of Airstream	316SS
Axle Bearings	Dual Bearing With Acetal Inner Sleeve, Flanged Outer Bearing	
Axle Material	½ Inch Plated Steel	316SS
Blade Seals	Silicone	
Jamb Seals	Silicone	



*W&H dimension furnished approximately ¼ in. (6mm) undersize.

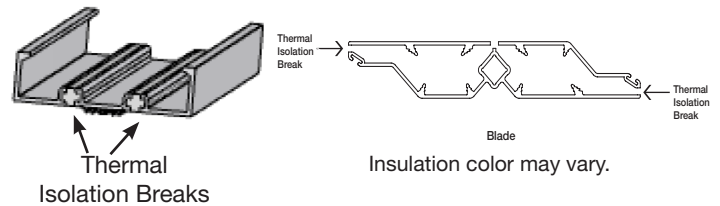

Size Limitations

in. (mm) W x H	Frame Type				
	Channel, Single or Reverse Flange		Quick Connect		
Blade Action	Parallel	Opposed	Parallel	Opposed	
Min. Size	Internal Mount	8 x 8 (203 x 203)	8 x 8 (203 x 203)	-	
	External Mount	8 x 7 (203 x 178)	8 x 7 (203 x 178)	8 x 6 (203 x 152)	8 x 6 (203 x 152)
Max. Size	Single Section	60 in. W x 78 in. H (1524mm x 1981mm)		60 in. W x 76 in. H (1524mm x 1930mm)	
	Multi-Section	180 in. W x 156 in. H (4572mm x 3962mm)		96 in. W x 152 in. H (2438mm x 3861mm)	

Actuator Sizing:

- Factory supplied actuator are sized for a full-open velocity of 1500 fpm (7 m/s) and fully-closed differential pressure of 2 in. wg (.5 kPa)
- Actuators supplied in the field for applications at velocities of 1500 fpm (7 m/s) or less and 2 in. wg of pressure or less shall use the following guidelines:
 - Opposed blade dampers: 7 in-lb per square foot of damper area with a minimum of 60 in-lb
 - Parallel blade dampers: 9 in-lb per square foot of damper area with a minimum of 60 in-lb
- Contact factory for actuator sizing on applications exceeding those limits

Options and Accessories

- Actuator: bracket only, manual quadrant, variety of 24V, 120V, actuators
- Actuator mounting; external and external kit
- Clean wrap
- [NEMA enclosures](#)
- [120V to 24V Transformer](#)
- [Multi-Voltage Transformer](#)

Blade Operation

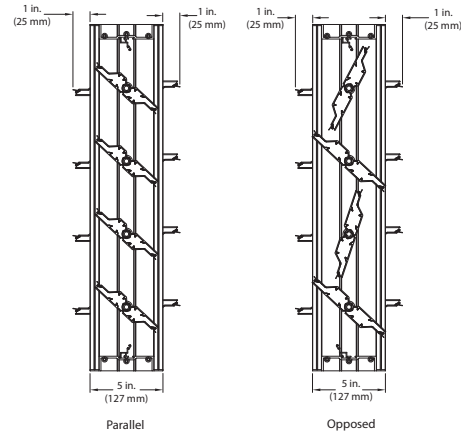

Frame/Flange Options

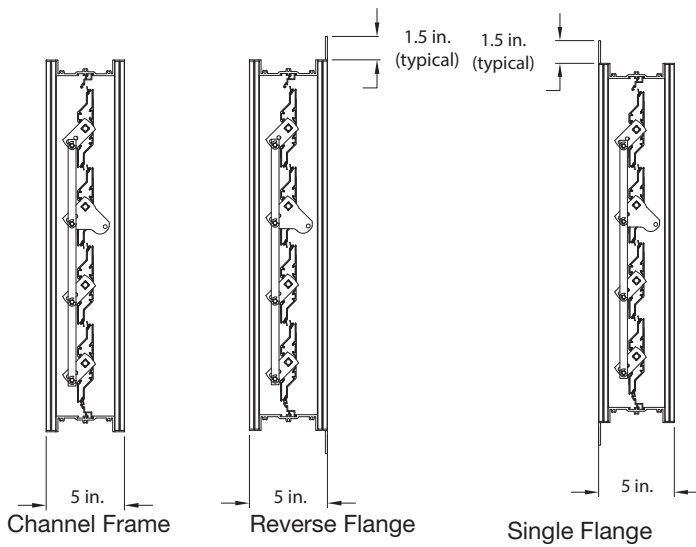

Quick Connect

Note: When ordering the Quick Connect Frame, size is based on duct size (or inside dimension of the damper frame). Quick Connect frame is actual size.

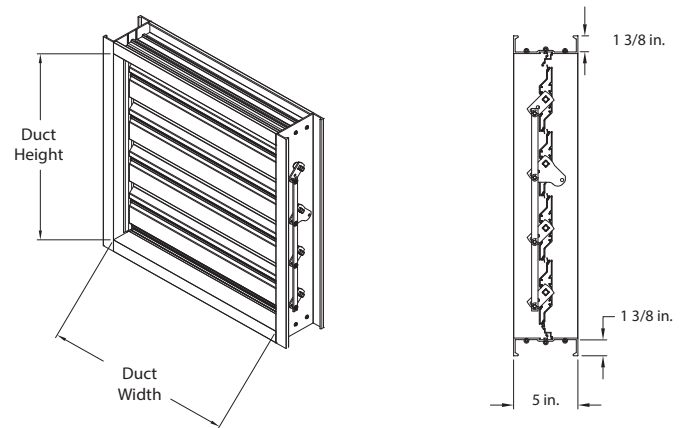

* Width and height is based on outside dimension. W & H dimensions furnished approximately 1/4 in. (6mm) undersize.

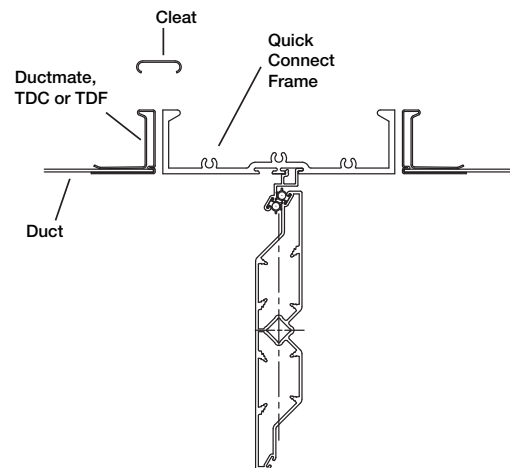

AMCA Pressure Drop

AMCA 5.2

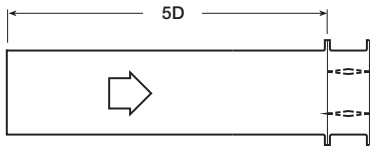

Greenheck Fan Corporation certifies that the model ICD-45 shown herein is licensed to bear the AMCA Seal. The ratings shown are based on tests and procedures performed in accordance with AMCA Publication 511 and comply with the requirements of the AMCA Certified Ratings Programs. The AMCA Certified Ratings Seal applies to Air Leakage, Air Performance and Energy Efficiency ratings.

12 x 12 (305mm x 305mm)	
Velocity (fpm)	Pressure Drop (in. wg)
500	.03
1000	.11
1500	.25
2000	.45
2500	.71
3000	1.03
3500	1.40
4000	1.83

24 x 24 (610mm x 610mm)	
Velocity (fpm)	Pressure Drop (in. wg)
500	.02
1000	.08
1500	.19
2000	.34
2500	.53
3000	.77
3500	1.05
4000	1.37

36 x 36 (914mm x 914mm)	
Velocity (fpm)	Pressure Drop (in. wg)
500	.01
1000	.05
1500	.11
2000	.21
2500	.33
3000	.47
3500	.64
4000	.84

12 x 48 (305mm x 1219mm)	
Velocity (fpm)	Pressure Drop (in. wg)
500	.01
1000	.06
1500	.14
2000	.25
2500	.40
3000	.57
3500	.78
4000	1.02

48 x 12 (1219mm x 305mm)	
Velocity (fpm)	Pressure Drop (in. wg)
500	.03
1000	.14
1500	.32
2000	.57
2500	.89
3000	1.29
3500	1.76
4000	2.30

AMCA 5.3

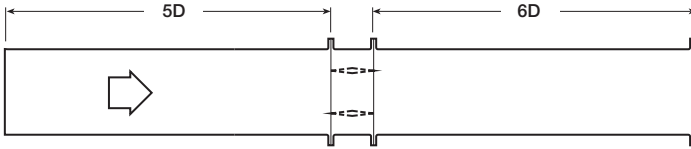

12 x 12 (305mm x 305mm)	
Velocity (fpm)	Pressure Drop (in. wg)
500	.01
1000	.04
1500	.09
2000	.17
2500	.26
3000	.38
3500	.52
4000	.67

24 x 24 (610mm x 610mm)	
Velocity (fpm)	Pressure Drop (in. wg)
500	.01
1000	.03
1500	.08
2000	.14
2500	.22
3000	.32
3500	.43
4000	.57

36 x 36 (914mm x 914mm)	
Velocity (fpm)	Pressure Drop (in. wg)
500	.01
1000	.02
1500	.04
2000	.08
2500	.12
3000	.18
3500	.24
4000	.32

12 x 48 (305mm x 1219mm)	
Velocity (fpm)	Pressure Drop (in. wg)
500	.01
1000	.02
1500	.06
2000	.10
2500	.17
3000	.24
3500	.33
4000	.43

48 x 12 (1219mm x 305mm)	
Velocity (fpm)	Pressure Drop (in. wg)
500	.01
1000	.06
1500	.14
2000	.25
2500	.40
3000	.58
3500	.79
4000	1.03

AMCA 5.5

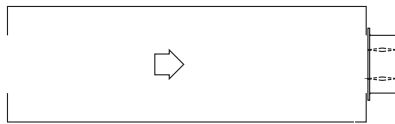

12 x 12 (305mm x 305mm)	
Velocity (fpm)	Pressure Drop (in. wg)
500	.05
1000	.23
1500	.52
2000	.93
2500	1.44
3000	2.08
3500	2.83
4000	3.70

24 x 24 (610mm x 610mm)	
Velocity (fpm)	Pressure Drop (in. wg)
500	.05
1000	.21
1500	.47
2000	.84
2500	1.32
3000	1.90
3500	2.59
4000	3.39

36 x 36 (914mm x 914mm)	
Velocity (fpm)	Pressure Drop (in. wg)
500	.04
1000	.14
1500	.33
2000	.58
2500	.91
3000	1.31
3500	1.79
4000	2.34

12 x 48 (305mm x 1219mm)	
Velocity (fpm)	Pressure Drop (in. wg)
500	.04
1000	.18
1500	.42
2000	.74
2500	1.16
3000	1.68
3500	2.28
4000	2.98

48 x 12 (1219mm x 305mm)	
Velocity (fpm)	Pressure Drop (in. wg)
500	.05
1000	.22
1500	.51
2000	.90
2500	1.41
3000	2.04
3500	2.78
4000	3.70

Leakage

AMCA Certified Leakage Data

Air leakage is based on operation between 32°F (0°C) and 120°F (49°C).

Tested for leakage in accordance with ANSI/AMCA Standard 500-D, Figure 5.5.

Tested for air performance in accordance with ANSI/AMCA Standard 500-D, Figures 5.2, 5.3 and 5.5.

Torque

Data are based on a torque of 9.0 in.lb./ft² (1.02 N·m) applied to close and seat the damper during the test.

ICD-45 Maximum Damper Width	Leakage Class*			
	1 in. wg (0.25 kPa)	4 in. wg (1 kPa)	8 in. wg (2 kPa)	10 in. wg (2.5 kPa)
60 in. (1524mm)	1A	1	1	1



Greenheck Fan Corporation certifies that the model ICD-45 shown herein is licensed to bear the AMCA Seal. The ratings shown are based on tests and procedures performed in accordance with AMCA Publication 511 and comply with the requirements of the AMCA Certified Ratings Programs. The AMCA Certified Ratings Seal applies to Air Leakage, Air Performance and Energy Efficiency ratings.

*Leakage Class Definitions

The *maximum* allowable leakage is defined by AMCA as the following:

- Leakage Class 1A - 3 cfm/ft² @ 1 in. wg (class 1A is only defined at 1 in. wg).
- Leakage Class 1
 - 4 cfm/ft² @ 1 in. wg
 - 8 cfm/ft² @ 4 in. wg
 - 11 cfm/ft² @ 8 in. wg
 - 12.6 cfm/ft² @ 10 in. wg

AMCA Certified Energy Efficiency Performance

Greenheck Model ICD-45 has a Thermal Efficiency Ratio of 941%.

A damper's Thermal Efficiency Ratio (E) is a comparison of the thermal performance of the tested damper with that of a standard reference damper, which is a 3V blade damper with blade and jamb seals. A damper with the same thermal efficiency as the reference damper would have an E of 0%. A damper that is twice as efficient as the reference damper would have an E of 100%.

Test Information

Testing was conducted on a 36"x36" sample in AMCA 500-D figure 5.10 per AMCA standard 500-D's Thermal Efficiency test.

Torque

Data are based on a torque of 9.0 in.lb./ft² (0.56 N·m) applied to close and seat the damper during the test.

Plenum Wall Installation

There are applications that require mounting an ICD-45 into a plenum wall. This illustration depicts how to mount an ICD-45 into a plenum wall.

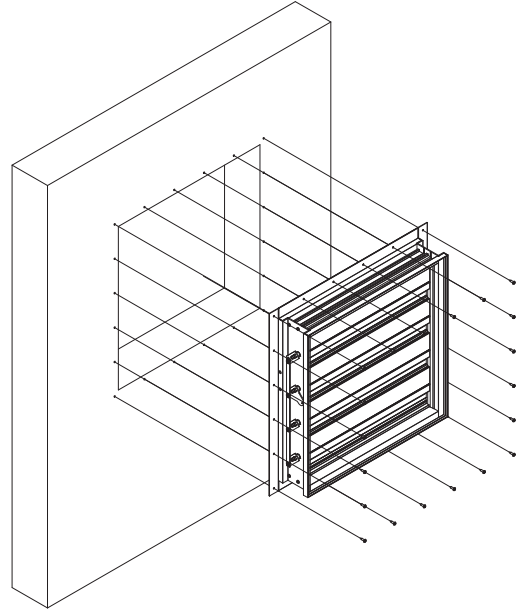

Actuator Mounting

Actuators may be installed at the factory, shipped loose with the necessary linkage and brackets for mounting, or field supplied. For more detail information on actuator mounting, click on link below or scan QR code.



[ACTUATOR MOUNTING](#)

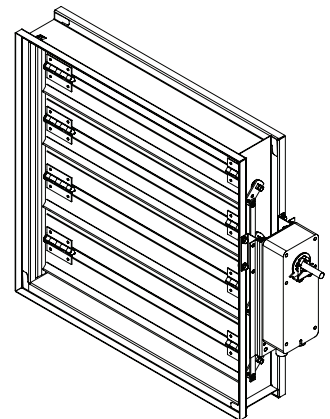

Non-jackshaft external right

Dampers larger than the maximum single section size, will be made up of a multiple of equal size sections.

NOTE: Dampers larger than 60 in. x 78 in. (1524mm x 1981mm) are not intended to be structurally self supporting. Refer to IOM document #468333 for structural support requirements on multi-section assemblies.

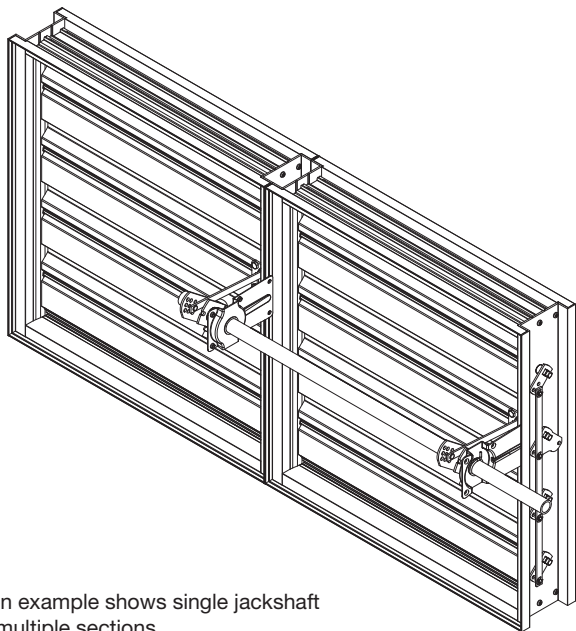

2 section example shows single jackshaft driving multiple sections

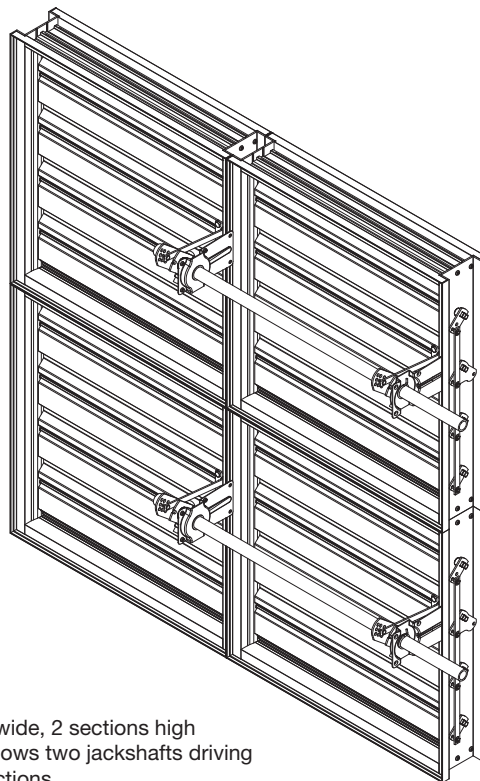

2 sections wide, 2 sections high example shows two jackshafts driving multiple sections

Document Links



[INSTALLATION](#)



[CATALOG](#)



[SELECTION GUIDE](#)



[SPECIFICATIONS](#)



[WARRANTY](#)