

## MANUALLY ADJUSTABLE-AT-REST VANEAXIAL FANS



Model VJ  
Direct Drive

**MODELS:** VJ / VJBD



## Overview

VJ | VJBD

Model VJBD,  
Arrangement 9



Model VJBD,  
Arrangement 4

The Type "J" vaneaxial fan is a proven workhorse for industrial ventilation applications. The blade pitch of the impeller is factory set for optimal efficiency, reducing the lifetime energy cost of ownership. The patented hub design also allows for the blade pitch to be field adjusted when actual site conditions in the ventilation system do not match design parameters. Cast of high strength aluminum alloy, the Type "J" impeller provides efficiency and reliability for your air movement requirements.

### Typical Applications Include

Gas Turbine Enclosure Exhaust, Generator Pressurization, Paint Spray Booth Exhaust, Paper and Pulp Process Exhaust, Mining Ventilation, Aerodynamic Wind Tunnels, Automotive Test Cells, General HVAC, Stairwell Pressurization

### Configurations

Direct and Belt Driven – vertical and horizontal mount configurations

### Impeller Type

Cast Aluminum

### Optional Construction

Clamshell Construction, Swingout Construction, AMCA Spark B Resistant Construction, Aluminum Housing, Hot Dip Galvanized Housing, 304SS Housing, 316SS Housing

### Certifications

AMCA Sound/Air and FEI, UL 705 Listed for Electrical

### Model Nomenclature

Type "J" model numbers are represented as follows.

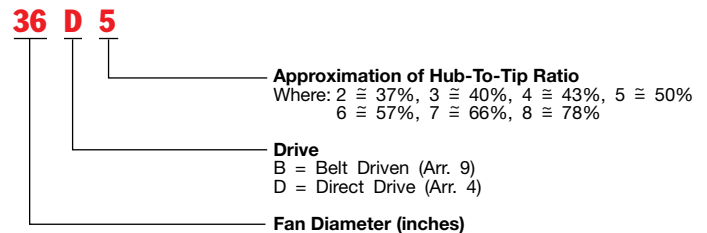

## Energy Regulations

Aerovent supports energy efficiency regulations enacted by the U.S. Department of Energy (DOE) and specific states. The selection and application of fan products is a significant part of these regulations. Engineers and specifiers must understand how to apply Aerovent products to their specific applications to meet applicable DOE and state regulatory requirements. Aerovent has made significant investments in product testing and development to provide efficient products. Developments in Aerovent's Fan Selector software are in place to aid your decision in product selection to assist with meeting the efficiency requirements as stipulated in the applicable regulations.



Aerovent, a Twin City Fan Company, certifies that the models shown herein are licensed to bear the AMCA Seal. Certified performance data may be found in Aerovent's Fan Selector software.



Scan the QR code to search Aerovent's AMCA-certified products.



Models VJ and VJBD are available with the UL/cUL 705 listing for electrical, File No. E158680.



For complete product performance, drawings and available accessories, download our Fan Selector software at [aerovent.com](http://aerovent.com).

## Applications

VJ | VJBD

### Ventilation

The Type "J" vaneaxial is a logical choice for any ventilation system, as either a supply or return fan. It can be ducted or provided with an inlet bell for open (or unducted) inlet installations. The ability to fine-tune the system performance through blade angle adjustment ensures the user of a highly efficient, economical, versatile, quiet and long-running fan.

### Industrial Process

The Type "J" vaneaxial is an ideal component for most industrial air systems. This unit is designed with a heavy-duty housing and large diameter shaft and bearings for rugged industrial service. The cast aluminum impeller alloy has strength qualities far exceeding common aluminum alloys, and the massive hub section makes the entire rotating assembly less sensitive to imbalance. The Type "J" vaneaxial housing and its accessories can also be provided in aluminum or stainless steel construction for corrosive applications.

### Smoke Exhaust/Stairway Ventilation

The Model VJ is the perfect choice for stairway ventilation. The requirement for stairway pressurization has increased due to more stringent public building codes. During an emergency exit, the need to create a positive pressure within the stairway enclosure ensures a safe exit way. For this application, the Model VJ uses a maintenance-free, direct drive motor and the blade adjustability allows fine-tuning of the system to the optimum point of rating.

### ATEX

The Type "J" vaneaxial is available for explosive environment applications where fans must meet the European Union's ATEX Manufacturer's Directive (94/9/EC). Currently, Aerovent offers fans suitable for Zone 2 and 22, Category 3 environments with special modifications. Fans modified for ATEX environments are not AMCA certified.

Consult our website ([http://www.aerovent.com/industries-and-applications/hazardous-locations-\(atex\)](http://www.aerovent.com/industries-and-applications/hazardous-locations-(atex))) or contact Aerovent for further information.



Dust Suppression Application

### Sizes and Performance

- Sizes 18" to 84" impeller diameters
- Hub available in 14", 18", 21", 27" and 30" diameters for various hub-to-tip ratios
- Airflow to 233,000 CFM
- Static pressures to 6" w.g.

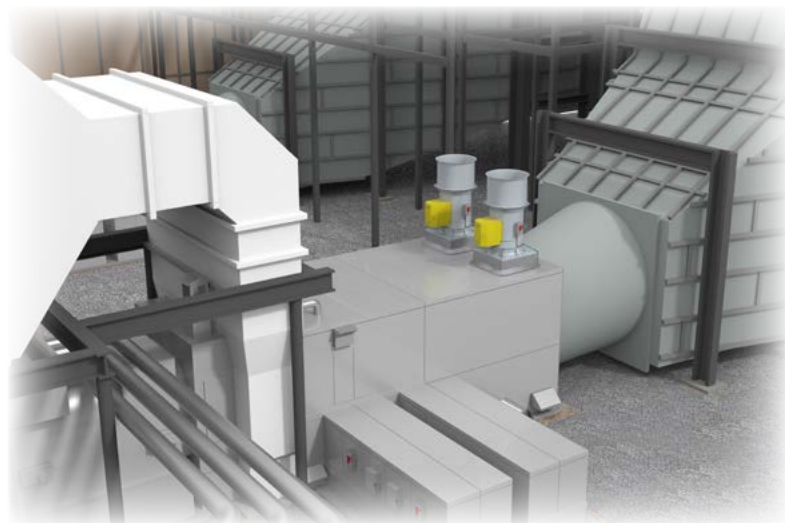

Gas Turbine Plant



**Housings** - Housings are constructed from one-piece, heavy-gauge, hot-rolled steel. Flanges are provided on both the inlet and outlet and are punched for attachment to ductwork or accessories. The seams are continuously-welded to prevent leakage, thus assuring maximum efficiency.

**Impeller/Fan Size Combinations** - Fan sizes range from 18" to 84" impeller diameters. Hubs are available in 14", 18", 21", 27" and 30" diameters. The blades can be cut to one of several diameters in order to provide various hub-to-tip ratios. Varying hub-to-tip ratios allow for different pressure and efficiency characteristics and the option of having several different impellers (different hub ratios) for a set diameter.

**Bearings** - Heavy-duty, grease lubricated, anti-friction ball or roller, self-aligning, pillow block type bearings, specifically designed for air handling applications to provide an average life (L-50) in excess of 200,000 hours at maximum cataloged operating speeds.

**Shaft** - AISI 1040 or 1045 hot rolled steel, accurately turned, ground, polished and ring gauged for accuracy.

**Drive** - Fixed or adjustable pitch V-belt drives with cast iron sheaves and anti-static conducting belts.

**Motors** - ODP, TEFC and explosion proof, single and three phase motors are carefully matched to the fan load.

**Vibration Isolation** - Fans can be provided with spring or rubber-in-shear isolators. Spring isolators are standard 1" deflection and can be provided for floor mount or ceiling hung orientation. Flexible connections are required on fans employing vibration isolation. Avoid collapsed flexible connections on the fan inlet.

**Inlet/Outlet Screen** - Safety screening can be provided for installation in the fan inlet, fan outlet, inlet/outlet cone or inlet bell.

**Curb Cap** - One-piece curb cap/inlet venturi assembly provides protection from weather. Prepunched mounting holes provide easy and accurate attachment to the roof curb.

**Guide Vanes** - The fan housing is fitted with airflow straightening guide vanes. These guide vanes are aerodynamically placed within the housing and are located downstream from the impeller. The vanes are stationary and welded to both the inner and outer cylinders to minimize turbulence downstream from the fan. This straightening effect aids the impeller in recovering rotative energy imparted to the air.



Model VJ,  
Marine Duty

## Spark Resistant Construction

Fan applications may involve the handling of fumes or vapors. Such applications require careful consideration by the system designer to ensure the safe handling of such gases. Aerovent offers spark resistant construction, type B per AMCA Standard 99-0401. It is the specifier's or the user's responsibility to specify the type of spark resistant construction with full recognition of the potential hazards and the degree of protection required.

**Type B** - The fan shall have a nonferrous impeller and nonferrous rub ring about the opening through which the shaft passes — usually aluminum impeller and rub ring and limited to 275°F. Consult factory for availability.

## Swingout Construction

Swingout construction provides easy access to the fan for cleaning and general maintenance without removing it from the ductwork. When quickopen clamp latches are released, the door swings out on heavy-duty hinges to provide out of the airstream access to the impeller for cleaning. For additional access to the shaft and bearings, a split inner cylinder is provided. Available in sizes 21-60. See dimensional data on page 15 for motor frame size limits.

## Clamshell Construction

Clamshell construction is ideal for applications needing regular cleaning. Depending on the size, one door (sizes 18-36) or two doors (sizes 42-60) are secured with quick access latches. These doors open outward and allow access to the internal components of the fan. As standard, there is an access door on the inner cylinder, allowing easy access to clean around the bearings. It is essential to follow proper safety precautions during cleaning. If bearing, shaft or impeller replacement is required, the fan should be removed from the ductwork or roof to facilitate safe replacement of parts. If replacement of these parts while ducted or on the roof is required, it is recommended to use swingout construction.

## Corrosion Resistant Construction

For handling corrosive fumes, etc. Fan casings can be constructed of hot dipped galvanized steel, stainless steel, aluminum or protected with a wide variety of suitable protective coatings.

## High Moisture Modification

A shaft seal and added gaskets to the bearing housing protect the rotor assembly from damage due to moisture ingress. Ideal for steam and high humidity applications.

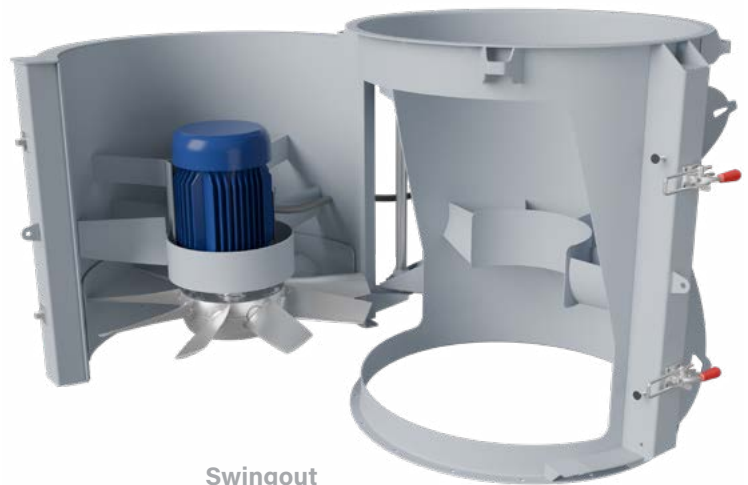

Swingout Construction



Clamshell Construction

# Blade Adjustment

The patented Type "J" blade design provides the customer with the ability to modify the blade angle in order to vary the performance when a speed adjustment is impractical or not feasible due to the absence of a variable frequency drive.

The blade angle is indexed in the area where the blade and hub meet. The ratings displayed in this catalog indicate the specific blade angle required and the blade should be set accordingly.

The fan name tag, supplied on the housing exterior, indicates the CFM, static pressure and corresponding blade angle setting for the specified flow rate and pressure.

Blade pitch adjustments can be accomplished by accessing the fan inlet, removing the bolts holding the aerodynamic hub cover and loosening the larger sized nuts (*do not loosen the small bolts on the hub*). See our installation and maintenance manual for specific instructions. When adjusting the blade angle, care must be taken not to overload the fan motor. Refer to the fan curves or consult your Aerovent sales representative to assure the fan is properly applied. Further care must be taken to be sure that all fan blades are adjusted to the same blade angle, thus ensuring proper airflow characteristics and balance.

**AEROVENT**   
INDUSTRIAL VENTILATION SYSTEMS



Type "J"  
Adjustable Impeller



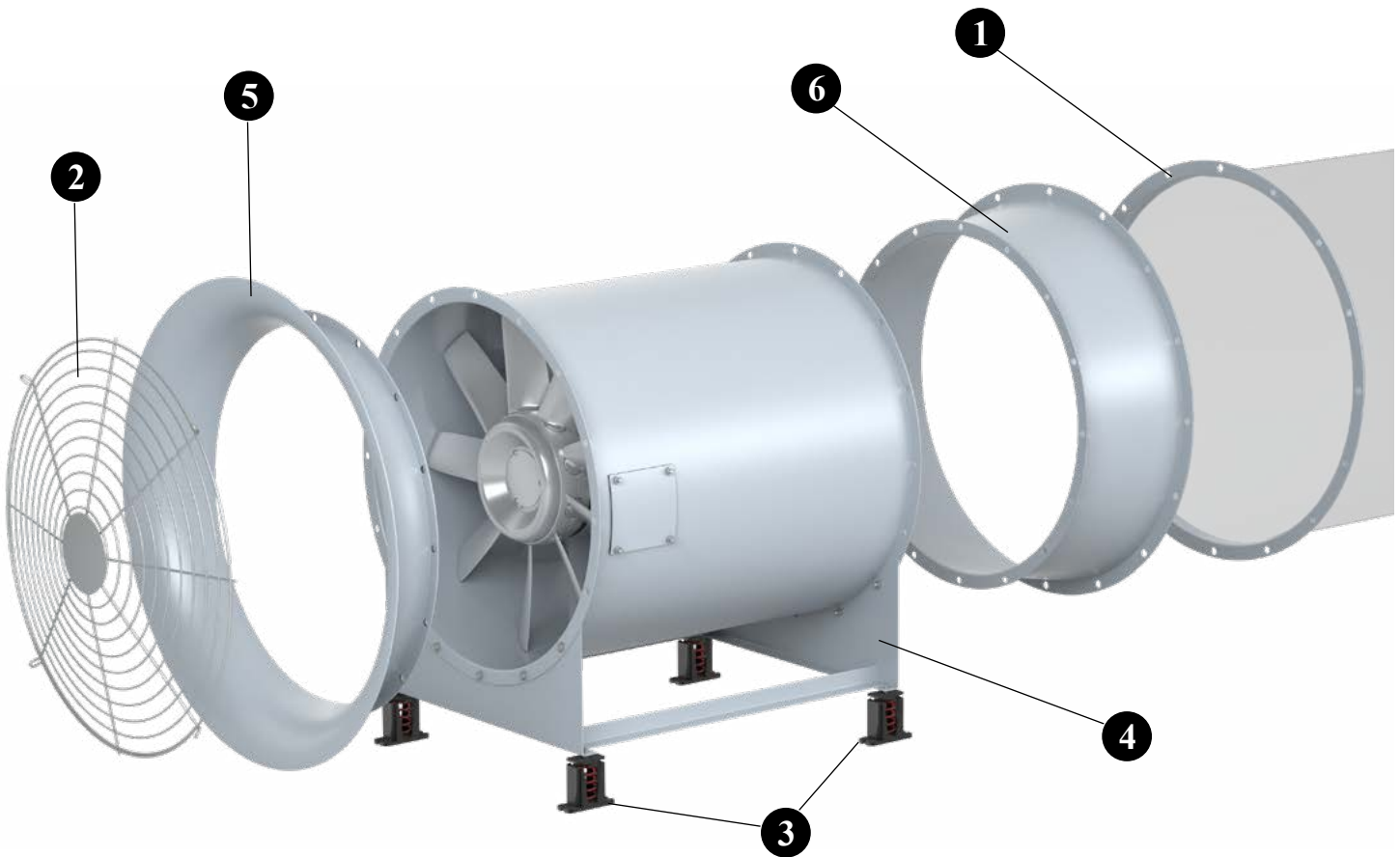

**1 Outlet Companion Flange** Companion flanges are commonly connected to a user's duct for easy installation of flexible connections between the fan and duct. Companion flanges and flex connectors are punched to match the fan's inlet or outlet hole patterns.

**2 Inlet Screens** Heavy-gauge screen mounted to fan inlet/outlet for easy removal.

**3 Floor Spring Isolators** All Model VJ/VJBD fans can be provided with spring or rubber-in-shear isolators. Spring isolators are standard 1" deflection and can be provided for floor mount or ceiling hung orientation. Flexible connections are required on fans employing vibration isolation. Avoid collapsed flexible connections on the fan inlet.

**4 Support Legs** For horizontal flow with floor mounting, support legs are welded to the fan flange with bolt holes aligned for connection of ductwork. For vertical flow with either floor or ceiling mounting, support legs are welded to the fan housing for four-point support.

**5 Inlet Bell** An inlet bell is recommended to minimize entrance losses for installations where the inlet of the fan is nonducted. Inlet bell is flanged and punched to mate up with the standard flanged inlet.

**6 Inlet/Outlet Cone** Heavy-gauge and flanged to match the fan flange bolt pattern to ensure smooth airflow and regain of velocity pressure.

#### Other Accessories Include:

- Access Door (General Observation)
- Shaft Seal
- RIS Isolators
- Roof Ventilator Packages (Upblast/Hooded or Filtered/Non-Filtered)
- Suspension Clips Horizontal Ceiling Hung

**AEROVENT**   
INDUSTRIAL VENTILATION SYSTEMS



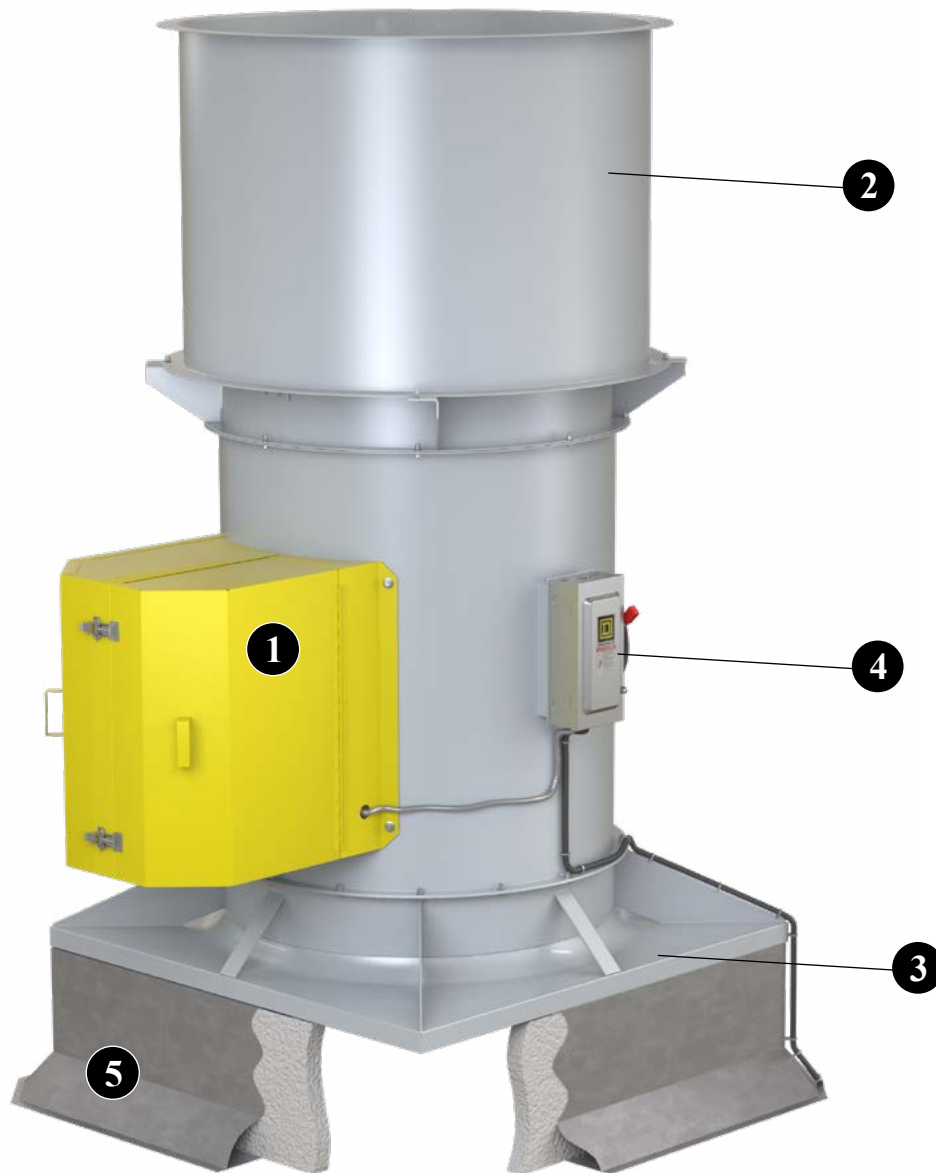

- 1 Weather Cover** For outdoor installations, the weather cover completely encloses the motor and V-belt drive from the elements. Available in one-piece or clamshell construction. Provided with slots for ventilation, the cover is easily removable for inspection and maintenance. Weather covers are available for either horizontal or vertical flow fans.
- 2 Stack Cap** Designed for vertical discharge with butterfly type dampers to seal out the weather when the fan is shut off and minimal flow obstruction when the fan is operating.
- 3 Curb Cap** Model VJ units can be supplied with a base (curb cap), attached to the fan's flange for curb mounting. The combination of a curb cap and stack cap creates an upblast-style power roof ventilator.
- 4 NEMA 3R Disconnect Switch** Disconnect switches offer superior environmental protection. From waterproofing to hazardous environments, know that you and your equipment are safe. Positive electrical shutoff during fan cleaning or maintenance provides additional safety and peace of mind. For more information about disconnect switches, see page 12.
- 5 Canted, Galvanized Insulated Curb** Prefabricated roof curbs are available in heavy-duty galvanized steel or aluminum construction, in heights of 8", 12" or 18". The canted curb is provided with a factory installed wood nailer. Curbs are provided with 1.5" of insulation as standard and feature continuously-welded seams for added rigidity and moisture protection. Prefabricated curbs are also available in raised cant, pitched and peak models.



## Waterproof Silencer Stack Cap

For applications requiring reduced noise levels, silencers can be provided. Silencers are aerodynamically and acoustically designed to significantly reduce noise emanating from the blower inlet or outlet while adding only minor resistance to the airflow. These silencers are designed for effective sound attenuation in the 63 to 8,000 Hz frequency range. The silencer is fabricated of a steel outer shell and a perforated inner shell. Silencers include mounting flanges.



## Pressure Drop and Acoustical Attenuation Data

The difference in sound power between the fan *without* a silencer and the fan *with* a silencer.

OUTLET VELOCITY (FPM)	STEEL	ALUMINUM
Min.	1700	1300
Max.	3000	3000

OCTAVE	63	125	250	500	1K	2K	4K	8K
Typical Insertion Loss	3	10	14	14	15	15	12	10

LW - Sound Power (dB) RE: 10-12 Watts  
 LP - Sound Pressure (dB) RE: 0.0002 MB

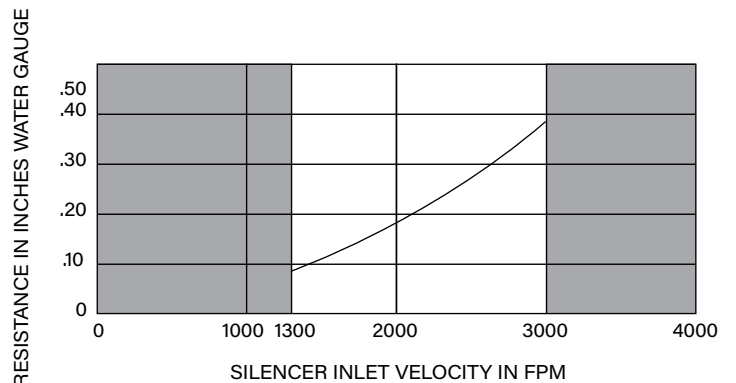

# Mounting Configurations

## Horizontal Construction

Horizontal construction is available in sizes 18 through 84.

**Horizontal Base Mounted (HBM)** — Support legs are provided at each end of the fan for floor mounting.

**Horizontal Ceiling Hung (HCH)** — For duct mounted fans, four suspension clips are welded to the fan casing to allow ceiling suspension using rod hangers.

**Horizontal (HOR)** — For mounting configurations where support legs and suspension clips are not required.

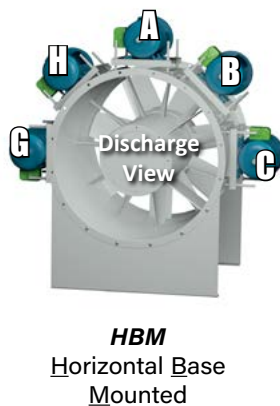
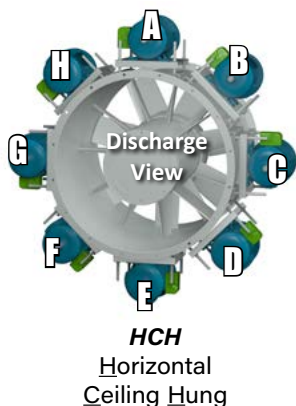

## Vertical Construction

Vertical construction is available in sizes 18 through 54. Consult factory for larger sizes.

**Floor or Ceiling Mounted (VUI/VUO/VDI/VDO)** — Four vertical brackets are welded to either end of the fan housing. Bracket location is determined by airflow direction and support details (see below).

**Roof Mounted (VRM)** — A curb cap provides weathertight seal for roof curb mounted fans. A stack cap and weather cover are also available for the upblast style roof ventilator.

**Vertical (VUN/VDN)** — For mounting configurations where support brackets are not required.



**VUS**  
Vertical Upblast  
with Stack Cap



**VUH**  
Vertical Upblast  
with Hood and  
Curb Cap



**VDH**  
Vertical Downblast  
with Hood and  
Curb Cap



**VUI**  
Vertical Discharge Up,  
Floor Mount Support  
Brackets On Inlet

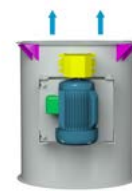

**VUO**  
Vertical Discharge Up,  
Ceiling Hung Support  
Brackets On Outlet



**VUN**  
Vertical Up  
No Brackets



**VDI**  
Vertical Discharge Down,  
Ceiling Hung Support  
Brackets On Inlet



**VDO**  
Vertical Discharge Down,  
Floor Mount Support  
Brackets On Outlet



**VDN**  
Vertical Down  
No Brackets

## Canted Roof Curbs

- Constructed of galvanized steel with continuously-welded seams
- Large 3" built-in 45° cant to accommodate roofing material to top of curb. Cant is beveled at corners for better support of roofing material
- Wood nailer (1½") secured to top ledge
- Lined with 1½" fiberglass fire-resistant, sound-absorbing insulation
- Damper shelf standard
- Options: Aluminum construction, burglar security bars, metal liner (galvanized or aluminum), special heights up to 24"



## Self-Flashing & Straight-Sided Roof Curbs

- Constructed of galvanized steel with continuously-welded seams
- Wide base plate (flashing) to ensure watertight seal to roof
- Top ledge covered with 3/16" polystyrene gasket (self-flashing) for weather seal and to reduce metal-to-metal conducted noise
- Wood nailer secured to top ledge (straight-sided)
- Lined with 1½" fiberglass fire-resistant, sound-absorbing insulation
- Damper shelf standard
- Straight-sided roof curbs are constructed with the same features as the self-flashing curbs, but are one dimensional to allow for field supplied cants and roofing material to be brought up to the top of the curb
- Options: Aluminum construction, burglar security bars, metal liner (galvanized or aluminum), special heights up to 24", single- or double-pitched curbs for sloping roofs



## Curb Adapters

- Constructed of galvanized steel with continuously-welded seams
- Top ledge covered with 3/16" polystyrene gasket to reduce metal-to-metal conducted noise and act as a weather seal
- Available in enlarger or reducer (shown) models



# Disconnect Switches

Disconnect switches provide positive electrical shutoff during fan cleaning or maintenance.



**NEMA 3R**  
Disconnect Switch



**NEMA 4**  
Disconnect Switch

## **NEMA 3R Disconnect Switch**

A NEMA 3R, rain proof, disconnect is available shipped loose for field mounting and wiring or factory mounted and wired externally.

## **NEMA 4 Disconnect Switch**

A NEMA 4, water and dust tight, disconnect is available shipped loose for field mounting and wiring or factory mounted and wired externally.

## **NEMA 7/9 Disconnect Switch**

A NEMA 7/9 disconnect switch is recommended on fans with explosion proof motors. The NEMA 7/9 switch is designed for use with fans operating in hazardous environments. Available shipped loose for field mounting and wiring.



**NEMA 7/9**  
Disconnect Switch



## Installations



Paper Machine Exhaust



Roof Exhaust



Paint Booth Exhaust



## Bare Fan Weights (lb)

FAN SIZE	VJ - ARRANGEMENT 4																					
	CLASS I - HUB RATIO							CLASS II - HUB RATIO							CLASS III - HUB RATIO							
	2	3	4	5	6	7	8	2	3	4	5	6	7	8	2	3	4	5	6	7	8	
18	—	—	—	—	—	—	169	—	—	—	—	—	—	—	198	—	—	—	—	—	—	208
21	—	—	—	—	—	—	226	—	—	—	—	—	—	276	—	—	—	—	—	—	290	—
24	—	—	—	—	—	267	—	—	—	—	—	303	—	—	—	—	—	—	—	318	—	—
28	—	—	—	296	—	417	—	—	—	—	348	—	465	—	—	—	—	372	—	—	471	—
32	—	—	328	—	443	612	—	—	—	378	—	497	670	—	—	—	395	—	519	692	—	—
36	—	—	—	498	650	—	—	—	—	—	566	716	—	—	—	—	—	594	752	—	—	—
42	—	—	688	845	—	922	—	—	—	824	998	—	1078	—	—	—	865	993	—	1152	—	—
48	—	—	950	—	1200	1380	—	—	—	1060	—	1315	1515	—	—	—	1113	—	1451	1691	—	—
54	—	1065	—	1135	1310	—	—	—	1270	—	1340	1545	—	—	—	1334	—	1388	1742	—	—	—
60	—	—	1325	1525	—	—	—	—	—	1490	1715	—	—	—	—	—	1543	1757	—	—	—	—
66	—	1560	1795	—	—	—	—	—	—	1560	1795	—	—	—	—	—	1618	1842	—	—	—	—
72	1675	1930	—	—	—	—	—	—	—	1675	1930	—	—	—	—	—	1739	1981	—	—	—	—
84	2100	—	—	—	—	—	—	—	—	2100	—	—	—	—	—	—	2159	—	—	—	—	—

FAN SIZE	VJBD - ARRANGEMENT 9																					
	CLASS I - HUB RATIO							CLASS II - HUB RATIO							CLASS III - HUB RATIO							
	2	3	4	5	6	7	8	2	3	4	5	6	7	8	2	3	4	5	6	7	8	
18	—	—	—	—	—	—	185	—	—	—	—	—	—	—	220	—	—	—	—	—	—	233
21	—	—	—	—	—	—	244	—	—	—	—	—	—	294	—	—	—	—	—	—	338	—
24	—	—	—	—	—	295	—	—	—	—	—	—	335	—	—	—	—	—	—	367	—	—
28	—	—	—	315	—	450	—	—	—	—	365	—	498	—	—	—	423	—	531	—	—	—
32	—	—	355	—	485	646	—	—	—	409	—	535	696	—	—	—	469	—	579	740	—	—
36	—	—	—	534	695	—	—	—	—	—	600	760	—	—	—	—	692	843	—	—	—	—
42	—	—	728	889	—	978	—	—	—	860	1037	—	1126	—	—	—	992	1169	—	1178	—	—
48	—	—	1027	—	1270	1460	—	—	—	1134	—	1380	1590	—	—	—	1284	—	1440	1670	—	—
54	—	1125	—	1160	1340	—	—	—	1330	—	1365	1570	—	—	—	1499	—	1432	1649	—	—	—
60	—	—	1537	1775	—	—	—	—	—	1735	2000	—	—	—	—	—	1809	2100	—	—	—	—
66	—	1935	2245	—	—	—	—	—	—	1995	2295	—	—	—	—	—	2077	2410	—	—	—	—
72	2135	2460	—	—	—	—	—	—	—	2235	2570	—	—	—	—	—	2324	2699	—	—	—	—
84	2675	—	—	—	—	—	—	—	—	2795	—	—	—	—	—	—	2935	—	—	—	—	—

## Accessory Weights (lb)

FAN SIZE	BELT GUARD	MOTOR COVER	INLET / OUTLET SCREEN	INLET BELL	INLET / OUTLET CONE	COMPANION FLANGE	SUPPORT LEGS		INLET VANES	STACK CAP	CURB CAP	SUSPENSION CLIPS
							HORIZ. FLOW	VERT. FLOW				
18	8	18	4	16	12	10	12	10	60	55	17	3
21	10	21	5	21	13	11	20	10	62	65	23	3
24	11	23	7	30	20	13	24	17	68	78	26	4
28	12	26	8	40	22	15	32	17	71	98	34	4
32	14	32	10	54	25	17	47	17	80	120	45	4
36	16	34	11	82	52	19	58	17	89	165	51	4
42	18	40	13	100	62	25	83	19	98	230	64	4
48	21	45	18	114	70	33	97	19	107	288	72	4
54	25	56	24	128	76	37	126	26	116	384	82	5
60	30	68	33	139	86	41	265	26	134	400	133	5
66	50	93	48	157	101	48	295	36	160	450	195	7
72	70	125	68	186	121	57	370	36	178	500	270	7
84	70	132	98	490	260	70	425	36	365	700	310	8

## Housing Gauges

FAN SIZE	ARRANGEMENT 4			ARRANGEMENT 9		
	CL I	CL II	CL III	CL I	CL II	CL III
18	10	7	7	12	7	7
21	10	7	7	12	7	7
24	10	7	7	10	7	7
28	10	7	7	10	7	7
32	10	7	7	10	7	7
36	10	7	7	10	7	7
42	7	0.25	0.25	7	0.25	0.25
48	7	0.25	0.25	7	0.25	0.25
54	7	0.25	0.25	7	0.25	0.25
60	0.25	0.25	0.25	7	0.25	0.25
66	0.25	0.25	0.25	0.25	0.25	0.25
72	0.25	0.25	0.25	0.25	0.25	0.25
84	0.25	0.25	0.25	0.25	0.25	0.25

## Stack Cap Limits

FAN SIZE	MINIMUM CFM TO OPEN		MAXIMUM CFM*
	STEEL/STAINLESS	ALUMINUM	
18	3058	2339	5577
21	4163	3184	7592
24	5426	4150	9895
28	7400	5659	13494
32	9644	7375	17586
36	12184	9317	22218
42	16650	12732	30361
48	21709	16601	39587
54	27404	20956	49972
60	33779	25831	61597
66	40936	31304	74648
72	48739	37271	88877
84	66181	50609	120683

\* Ask about our extra heavy-duty stack cap if your CFM exceeds the maximum CFM.

NOTE: The terminal velocity of rain is approximately 2,000 feet per minute. Selections below this point are not recommended if rain entry into the building is a concern.

# Dimensional Data

VJ - ARR. 4 - HORIZONTAL

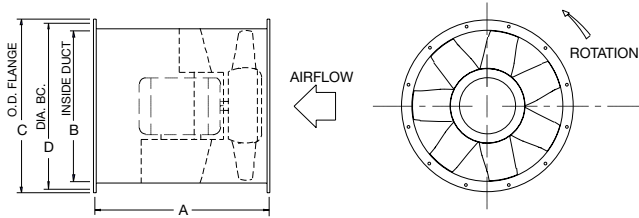

VJBD - ARR. 9 - HORIZONTAL

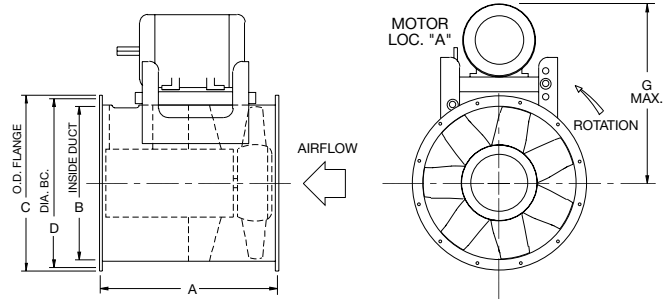

**HORIZONTAL DISCHARGES**

**HOR** = Horizontal - No Clips or Legs

**HCH** = Horizontal Ceiling Hung with Suspension Clips

**HBM** = Horizontal Base Mounted with Support Legs

VJ - ARR. 4 - VERTICAL

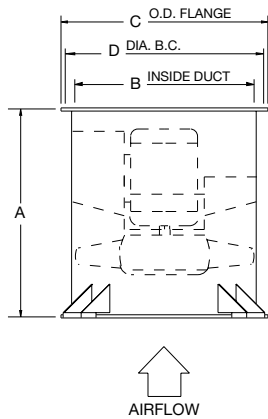

VJBD - ARR. 9 - VERTICAL

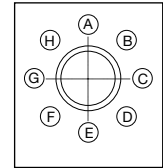
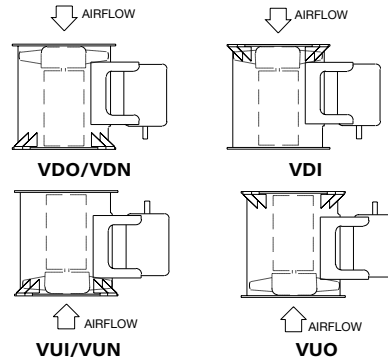
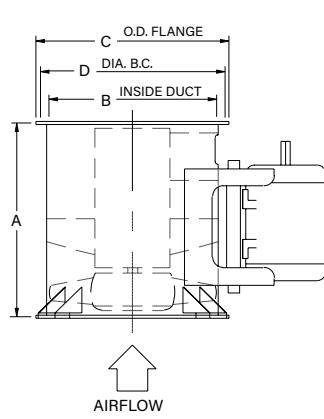

**HORIZONTAL MOTOR LOCATIONS (VIEWED FROM FAN OUTLET)**

**VERTICAL DISCHARGES**

**VDO** = Vertical Down Floor Mounted With Legs  
**VDN** = Vertical Down Discharge Without Legs

**VDI** = Vertical Down Ceiling Hung With Legs  
**VUI** = Vertical Up Floor Mounted With Legs

**VUN** = Vertical Up Discharge Without Legs  
**VUO** = Vertical Up Ceiling Hung With Legs

**ARR. 4 - ROOF VENTILATOR**

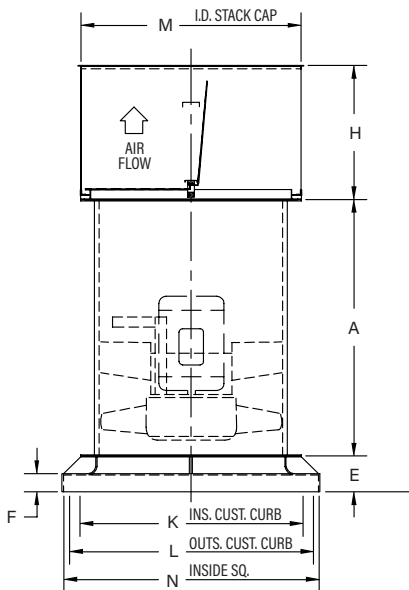

**ARR. 9 - ROOF VENTILATOR**

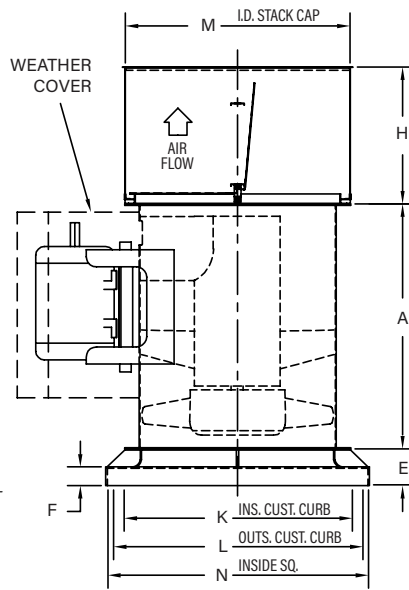

FAN SIZE	E	F	H	K	L	M	N
18	9.38	2.75	21.63	25.00	32.25	26.88	32.75
21	9.38	2.75	21.63	25.00	32.25	26.88	32.75
24	6.75	2.75	24.63	32.88	37.25	34.00	37.75
28	6.75	2.75	24.63	32.88	37.25	34.00	37.75
32	6.75	2.75	26.63	36.88	45.25	38.00	45.75
36	7.25	2.75	28.63	40.88	49.25	42.00	49.75
42	7.75	2.75	31.63	46.88	53.75	48.75	54.25
48	7.75	2.75	34.63	52.88	61.25	54.75	61.75
54	9.94	1.94	37.63	60.00	67.25	60.75	67.75
60	11.25	2.75	40.63	66.00	74.25	66.75	74.75
66	12.00	2.75	43.63	72.00	77.75	72.75	78.25
72	12.00	2.75	49.63	84.50	88.25	78.75	88.75

AC16808A AC16812A  
 AC16809A AC16813A  
 AC16810 AC16814  
 AC16811 AC16815

DIMENSIONS ARE NOT TO BE USED FOR CONSTRUCTION. CERTIFIED DRAWINGS AVAILABLE UPON REQUEST.

FAN SIZE	A													
	ARRANGEMENT 9 — HUB RATIO													
	2		3		4		5		6		7		8	
	CL I & II	CL III	CL I & II	CL III	CL I & II	CL III	CL I & II	CL III	CL I & II	CL III	CL I & II	CL III	CL I & II	CL III
18	—	—	—	—	—	—	—	—	—	—	—	—	—	—
21	—	—	—	—	—	—	—	—	—	—	—	—	—	—
24	—	—	—	—	—	—	—	—	—	—	—	—	—	—
28	—	—	—	—	—	—	—	—	—	—	—	—	—	—
32	—	—	—	—	—	—	—	—	—	—	—	—	—	—
36	—	—	—	—	—	—	—	—	—	—	—	—	—	—
42	—	—	—	—	—	—	—	—	—	—	—	—	—	—
48	—	—	—	—	—	—	—	—	—	—	—	—	—	—
54	—	—	—	—	—	—	—	—	—	—	—	—	—	—
60	—	—	—	—	—	—	—	—	—	—	—	—	—	—
66	—	—	—	—	—	—	—	—	—	—	—	—	—	—
72	55.00	60.25	60.25	60.25	—	—	—	—	—	—	—	—	—	—
84	60.25	60.25	—	—	—	—	—	—	—	—	—	—	—	—

1001912  
1001913  
1001914  
1001915  
1001916  
1001917  
1001918  
1001919  
1001920  
1001921  
1001922  
1001923  
1001924  
1001925  
1001926  
1001927

FAN SIZE	A																				
	ARRANGEMENT 4 — HUB RATIO																				
	2			3			4			5			6			7			8		
	CL I	CL II	CL III	CL I	CL II	CL III	CL I	CL II	CL III	CL I	CL II	CL III	CL I	CL II	CL III	CL I	CL II	CL III	CL I	CL II	CL III
18	—	—	—	—	—	—	—	—	—	—	—	—	—	—	—	—	—	—	—	—	—
21	—	—	—	—	—	—	—	—	—	—	—	—	—	—	—	—	—	—	—	—	—
24	—	—	—	—	—	—	—	—	—	—	—	—	—	—	—	—	—	—	—	—	—
28	—	—	—	—	—	—	—	—	—	—	—	—	—	—	—	—	—	—	—	—	—
32	—	—	—	—	—	—	—	—	—	—	—	—	—	—	—	—	—	—	—	—	—
36	—	—	—	—	—	—	—	—	—	—	—	—	—	—	—	—	—	—	—	—	—
42	—	—	—	—	—	—	—	—	—	—	—	—	—	—	—	—	—	—	—	—	—
48	—	—	—	—	—	—	—	—	—	—	—	—	—	—	—	—	—	—	—	—	—
54	—	—	—	—	—	—	—	—	—	—	—	—	—	—	—	—	—	—	—	—	—
60	—	—	—	—	—	—	—	—	—	—	—	—	—	—	—	—	—	—	—	—	—
66	—	—	—	—	—	—	—	—	—	—	—	—	—	—	—	—	—	—	—	—	—
72	45.00	53.25	57.00	45.00	53.25	57.00	—	—	—	—	—	—	—	—	—	—	—	—	—	—	—
84	45.00	63.00	66.00	—	—	—	—	—	—	—	—	—	—	—	—	—	—	—	—	—	—

FAN SIZE	B	C (MAX.)	D	G (MAX.)		
				CL I	CL II	CL III
				18	18.16	21.16
21	21.19	24.19	22.88	31.75	31.88	31.88
24	24.19	27.19	25.88	34.50	33.75	33.75
28	28.25	31.25	30.00	38.25	39.63	39.63
32	32.25	35.25	34.00	41.00	41.56	41.56
36	36.25	40.25	38.00	45.25	47.13	47.13
42	42.38	46.38	44.63	49.50	52.75	52.75
48	48.38	53.38	50.63	53.25	56.88	56.88
54	54.38	59.38	56.63	59.00	62.88	62.88
60	60.38	66.38	63.38	60.25	66.44	66.44
66	66.44	72.44	69.38	64.00	69.88	69.88
72	72.50	78.50	75.50	67.25	73.25	73.25
84	84.50	90.50	88.00	73.25	79.25	79.25

FAN SIZE	MAXIMUM MOTOR FRAME			
	ARRANGEMENT 9			SWINGOUT FANS
	CL I	CL II	CL III	
18	215T	256T	256T	—
21	256T	256T	256T	256T
24	256T	286T	286T	256T
28	286T	326T	365T	286T
32	286T	326T	405T	286T
36	326T	365T	405T	326T
42	326T	405T	445T	326T
48	365T	405T	445T	365T
54	365T	445T	445T	365T
60	365T	445T	445T	365T
66	365T	445T	445T	—
72	365T	445T	445T	—
84	365T	445T	445T	—

FAN SIZE	MAXIMUM MOTOR FRAME																									
	ARRANGEMENT 4 — CL I — HUB RATIO							ARRANGEMENT 4 — CL II — HUB RATIO							ARRANGEMENT 4 — CL III — HUB RATIO						ARR. 4 SWINGOUT					
	2	3	4	5	6	7	8	2	3	4	5	6	7	8	2	3	4	5	6	7		8				
18	—	—	—	—	—	—	145T	—	—	—	—	—	—	—	—	184T	—	—	—	—	—	—	—	—	—	—
21	—	—	—	—	—	—	145T	—	—	—	—	—	—	—	—	215T	—	—	—	—	—	—	—	—	—	—
24	—	—	—	—	—	—	184T	—	—	—	—	—	—	—	—	215T	—	—	—	—	—	—	—	—	—	—
28	—	—	—	—	—	—	184T	—	—	—	—	—	—	—	—	256T	—	—	—	—	—	—	—	—	—	—
32	—	—	—	—	—	—	256T	—	—	—	—	—	—	—	—	286T	—	—	—	—	—	—	—	—	—	—
36	—	—	—	—	—	—	256T	—	—	—	—	—	—	—	—	326T	—	—	—	—	—	—	—	—	—	—
42	—	—	—	—	—	—	286T	—	—	—	—	—	—	—	—	326T	—	—	—	—	—	—	—	—	—	—
48	—	—	—	—	—	—	326T	—	—	—	—	—	—	—	—	365T	—	—	—	—	—	—	—	—	—	—
54	—	—	—	—	—	—	365T	—	—	—	—	—	—	—	—	405T	—	—	—	—	—	—	—	—	—	—
60	—	—	—	—	—	—	365T	—	—	—	—	—	—	—	—	445T	—	—	—	—	—	—	—	—	—	—
66	—	—	—	—	—	—	—	—	—	—	—	—	—	—	—	445T	—	—	—	—	—	—	—	—	—	—
72	365T	365T	—	—	—	—	—	—	—	—	—	—	—	—	—	445T	—	—	—	—	—	—	—	—	—	—
84	365T	—	—	—	—	—	—	—	—	—	—	—	—	—	—	449T	—	—	—	—	—	—	—	—	—	—

DIMENSIONS ARE NOT TO BE USED FOR CONSTRUCTION. CERTIFIED DRAWINGS AVAILABLE UPON REQUEST.

# Dimensional Data

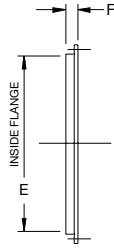

**COMPANION  
FLANGE**

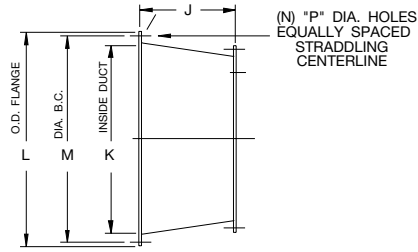

**CONE**

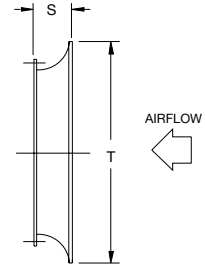

**INLET BELL**

FAN SIZE	COMPANION FLANGE		CONE						INLET BELL		FAN AREA (FT <sup>2</sup> )	CONE AREA (FT <sup>2</sup> )
	E	F	J	K	L	M	N	P	S	T		
18	18.16	1.50	8.50	21.19	24.50	22.88	8	0.56	3.71	23.72	1.80	2.45
21	21.19	1.50	8.50	24.19	27.50	25.88	12	0.56	4.31	27.67	2.45	3.19
24	24.19	1.50	11.50	28.25	31.56	30.00	12	0.56	4.96	31.63	3.19	4.35
28	28.25	1.50	11.50	32.25	35.56	34.00	12	0.56	5.75	36.90	4.35	5.67
32	32.25	1.50	11.50	36.25	39.56	38.00	16	0.56	6.54	42.17	5.67	7.17
36	36.25	1.50	17.00	42.38	46.81	44.63	16	0.69	7.39	47.44	7.17	9.80
42	42.38	2.00	17.00	48.38	52.81	50.63	16	0.69	8.59	55.34	9.80	12.77
48	48.38	2.00	17.00	54.38	58.69	56.63	16	0.69	9.76	63.25	12.77	16.13
54	54.38	2.00	17.00	60.38	64.94	63.38	20	0.69	10.98	71.16	16.13	19.88
60	60.38	3.00	17.00	66.44	70.94	69.38	24	0.69	12.20	79.06	19.88	24.08
66	66.44	3.00	17.00	72.94	76.94	75.50	24	0.81	11.75	78.88	24.08	29.02
72	72.44	3.00	33.00	84.50	91.13	88.00	24	0.81	12.00	84.00	28.62	38.94
84	CF	CF	34.00	96.63	103.00	100.00	24	0.75	12.00	96.19	38.94	50.79

CF = CONSULT FACTORY

DIMENSIONS ARE NOT TO BE USED FOR CONSTRUCTION. CERTIFIED DRAWINGS AVAILABLE UPON REQUEST.





## Model

VJ | VJBD



Fans, where indicated on drawings and schedules, shall be Arrangement 9, Type "J" Model VJBD Vaneaxial with the impeller mounted on a separate shaft and bearings supported completely within an enclosed tube isolated from the high velocity airstream or Arrangement 4, Type "J" Model VJ Vaneaxial with the impeller mounted directly on the motor shaft and with the impeller and motor assembly enclosed entirely within the fan casing.

**PERFORMANCE** — Fans shall be tested in accordance with AMCA 211 and AMCA 311 test codes for air moving devices and shall be guaranteed by the manufacturer to deliver rated published performance levels. Fans shall be licensed to bear the AMCA certified ratings seal for both sound and air.

**CONSTRUCTION** — Fan housings shall be of welded one-piece, hot rolled steel. The housing seam shall be continuously-welded and ground smooth for less resistance to airflow. Inlet and outlet flanges are standard.

**GUIDE VANES** — Fan housings shall be fitted with eleven aerodynamically designed stationary straightening guide vanes on the air discharge side of the fan impeller. Vanes shall be welded to both the housing and the inner cylinder and act to straighten the swirling motion of the air downstream of the fan blades, thereby recovering rotational energy losses, improving efficiency and static pressure capability, reducing power requirements, and reducing fan noise generation.

**IMPELLER** — The fan impeller shall be of individually manually adjustable blade pitch design and shall consist of a hub and blade assembly of aluminum alloy castings. The impeller shall have blades of airfoil shape designed with a variable hub ratio system to allow the selected fan to operate at the highest efficiency possible. The blade pitch angle shall be field adjustable by accessing the fan inlet. Blade angle markings shall be permanently cast into each blade socket on the hub and a corresponding index mark shall be permanently cast into the blade root. The fan impeller assembly shall be machined to the proper diameter so that blade tip clearance shall be within tolerance necessary to ensure certified fan performance. The fan impeller shall be secured to the fan/motor shaft with a taper lock bushing. The blade angle is to be factory set at the blade angle required to achieve the specified flow rate and pressure. This blade angle shall be indicated on the fan nameplate.

**SHAFT (VJBD ONLY)** — Shafts shall be AISI 1040 or 1045 hot rolled steel, accurately turned, ground, polished and ring-gauged for accuracy. Shafts shall be sized for the first critical speed of at least 1.43 times the maximum speed.

**BEARINGS (VJBD ONLY)** — Bearings shall be heavy-duty, grease lubricated, anti-friction ball or roller, self-aligning, pillow block type and selected for a minimum average bearing life (AFBMA L-50) in excess of 200,000 hours at the maximum fan RPM. All bearings shall be provided with pre-filled factory extended lubrication lines fitted with grease fittings terminating at the housing exterior.

**DRIVE (VJBD ONLY)** — Fans shall be equipped with a (fixed/adjustable) pitch V-belt drive selected to operate at the required RPM. The V-belt drive is to consist of cast iron sheaves and anti-static conducting belts. Drives shall be selected with a (1.5) service factor based upon the required brake horsepower of the fan.

The complete fan shaft and bearing assembly is mounted within a steel fabricated inner cylinder. The V-belt drive assembly is extended through a two-piece belt fairing, which is continuously-welded to both the housing and inner cylinder, thus avoiding any direct contact between the belts and high velocity airstream. The belt fairing is to be an aerodynamically shaped tube designed to maximize fan efficiency, minimize air blockage and reduce noise generation.

**MOTOR** — Motors for Arrangement 9 VJBD fans shall be manufactured in accordance with current applicable standards of IEEE and NEMA and, where applicable, shall meet current NEMA Premium Efficiency standards. Motors shall be foot-mounted, NEMA standard (ODP, TEFC, Explosion-Proof), continuous-duty, ball bearing type with class (B, F) insulation and of cast iron construction when commercially available.

Motors for Arrangement 4 VJ fans shall be foot-mounted, NEMA standard, totally enclosed fan cooled (TEFC), continuous-duty, ball bearing type with class "F" insulation and of cast iron construction when commercially available. For ease in wiring the motor, wiring connections shall be extended to an exterior conduit box located on the exterior of the fan casing. A duplicate motor nameplate is to be mounted on the exterior of the fan adjacent to the fan nameplate. External grease fittings with pre-filled factory extended grease leads shall be supplied for lubrication of the motor bearings on all motors that provide grease fittings. Motor bearings shall have a minimum of L-10 life as defined by AFBMA of at least 40,000 hours (200,000 hours average life).

**FINISH** — The entire fan assembly, excluding the impeller and shaft, shall be properly washed and pretreated before application of a rust-preventative primer, if called out on the order. After the fan is completely assembled, a finish coat of paint shall be applied to the entire assembly, if called out on the order. The fan shaft shall be coated with a petroleum-based rust protectant.

**ACCESSORIES** — When specified, accessories shall be provided by Aerovent to maintain one-source responsibility.

**FACTORY RUN TEST** — All fans with motors and drives mounted by Aerovent shall be completely assembled and test run as a unit at the specified operating speed prior to shipment. Each impeller shall be statically and dynamically balanced in accordance with ANSI/AMCA 204-96 "Balance Quality and Vibration Levels for Fans" to Fan Application Category BV-3, Balance Quality Grade G6.3. Balance readings shall be taken by electronic type equipment in the axial, vertical and horizontal directions on each of the bearings. Records shall be maintained and a written copy shall be available upon request.





---

**WALL MOUNTED FANS | TUBEAXIAL & VANEAXIAL FANS | CENTRIFUGAL FANS & BLOWERS**  
**ROOF VENTILATORS | AIR HEATERS & COOLERS | AIR MAKE-UP | FIBERGLASS FANS | CUSTOM FANS**

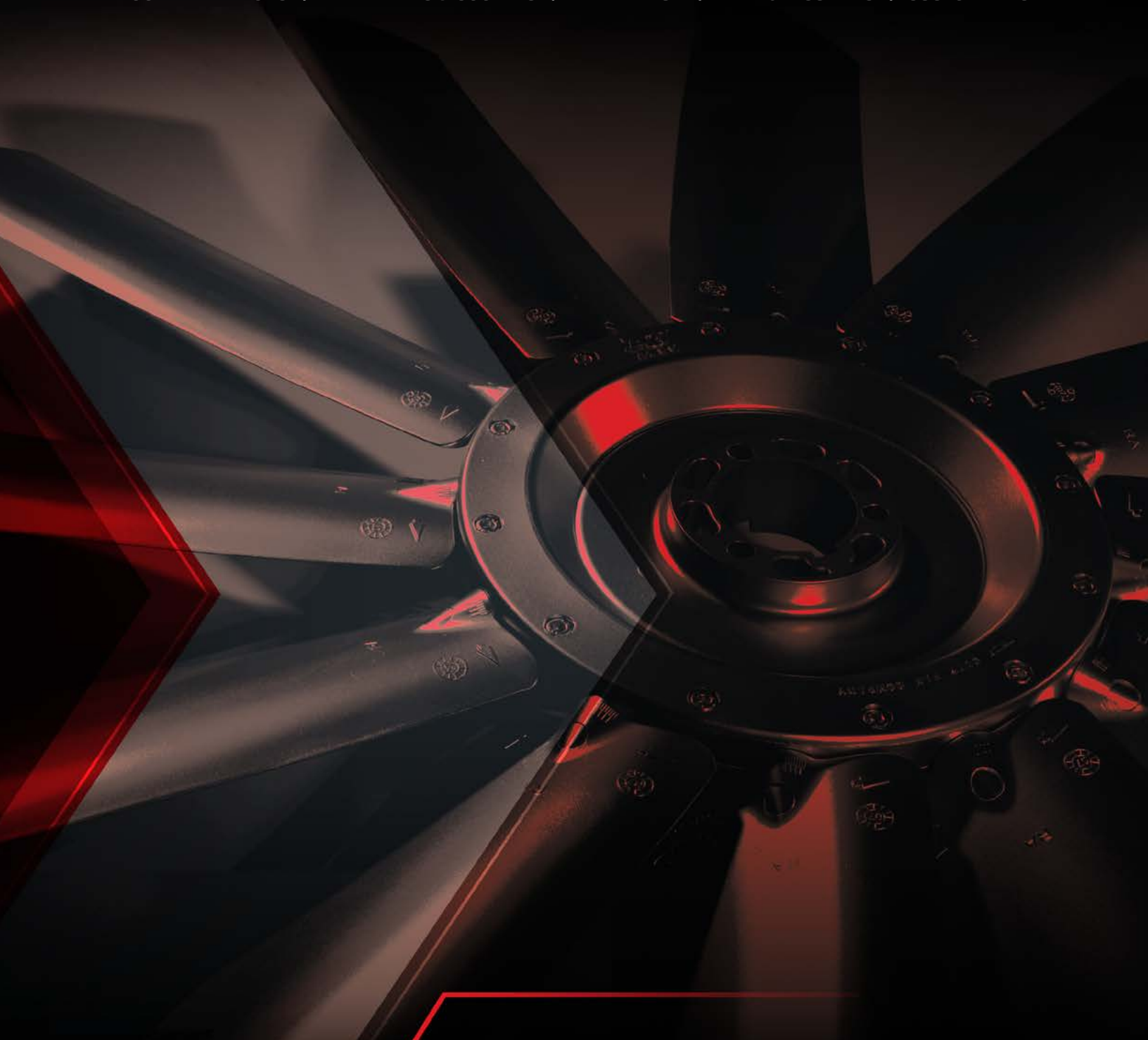

**AEROVENT**   
INDUSTRIAL VENTILATION SYSTEMS

**AEROVENT.COM**

---

**5959 Trenton Lane N. | Minneapolis, MN 55442 | Phone: 763-551-7500 | Fax: 763-551-7501**

©2005-2024 Aerovent, Minneapolis, MN. All rights reserved. Catalog illustrations cover the general appearance of Aerovent products at the time of publication and we reserve the right to make changes in design and construction at any time without notice.