

Vane Axial Flow Fans

- Direct Driven
- Belt Driven

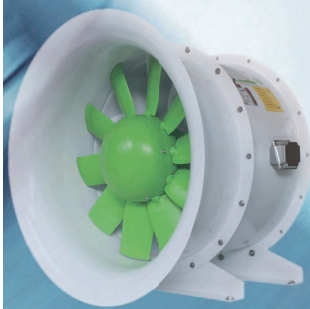
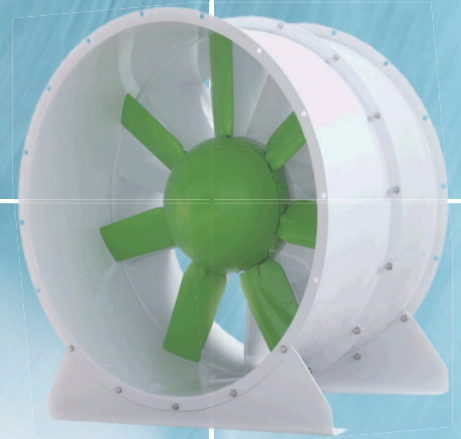

Air in Motion.

Wolter Fans.

A09-F

wolter 

Table of Content



Content.....	1
Technical Information.....	2-4
Fan Type Code.....	2
Design Features.....	2
Types and Duty Range.....	2
Application.....	2
Casing.....	2
Impellers.....	2
Motor.....	2
Fan Performance Curves.....	2
Sound Levels.....	2
Belt Driven Design.....	2
Ordering Designations.....	2
Fan Selection and Installation.....	3
Forms of Running.....	3
Selection Example.....	4
Fan Efficiency Grade - 50Hz.....	5
Performance Curve - 50Hz.....	6-23
Fan Energy Index - 50Hz.....	24-30
Fan Efficiency Grade - 60Hz.....	31
Performance Curve - 60Hz.....	32-49
Fan Energy Index - 60Hz.....	50-55
Dimensions.....	56-59
Sound Information.....	60-62
Tubular Sound Attenuator.....	63-64

Subject to change without prior notice.

Fan type code

AXV-F 1400 / 20°

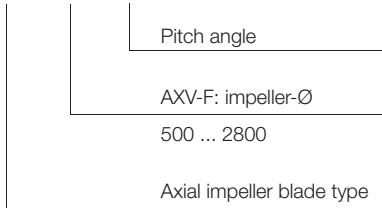

Dongguan Wolter Chemco Ventilation Ltd. certifies that the series AXV-F shown herein are licensed to bear the AMCA Seal. The ratings shown are based on tests and procedures performed in accordance with AMCA Publication 211 and AMCA Publication 311 and comply with the requirements of the AMCA Certified Ratings Program.

Design features

Types and duty range

Wolter vane axial high pressure fans can be used for various applications in ventilation and process air technology. Standard diameters range from 500 to 2,800 mm, with airflow rates of up to 260 m³/s at static pressure increases of up to 2,500 Pa. The high efficiencies and high pressures are achieved by the use of the aerodynamically designed guide vanes.

Application

The AXV-F range of vane axial fans is designed, tested and certified to operate at standard temperatures as well as at elevated temperatures of maximum up to 600deg/C for 120 minutes inclusive of F600 (600deg/120mins), F400 (400deg/120mins) and F300 (300deg/60mins) according to EN 12101-3:2015. The following fan curves are valid for standard temperatures and 300°/60(120) minutes operation. To select a fan for 400°C/120 minutes and 600°C/120 minutes operation, please contact our technical support. For F600, fans come in bifurcated and belt driven configuration with motor out of air flow.

Well suited for industrial applications, ventilation, smoke exhaust, stair case pressurisation and for conveying clean and dusty air where medium to high pressures are required with high airflow volume and fan efficiency.

Casing

Fan are made of steel, with flanges rolled on both sides. The pitch circles of holes are in accordance with DIN 24 154, R2. The fan casings are hot dipped galvanised as standard. Optional: Optimal corrosion protection by powder-coating.

If motors require additional lubrication, tubes and grease-nipples are fitted to the outside of the fan casing. An inspection hole, closed by a rubber plug, allows controlling the direction of rotation.

Impellers

Hubs and impeller blades are made of highly corrosion resistant pressure-cast aluminium alloy. Optional: Hub and aerofoil profiled blades made of steel for F600. The aero dynamical profile of the impeller blades guarantees a high level of efficiency and low noise. The blade angle is adjustable during standstill. The variable number of blades expands the performance range. Dynamically balanced according to DIN ISO 1940-1, balancing quality G6.3.

Motors

Wolter uses closed squirrel cage motors according to IEC 34, if required also in accordance with EPACT. Standard motors are class F with IP 55 protection class. Multi speed versions with 2 or 3 speeds (Dahlander circuit or separate windings) are also available, as well as explosion-proof versions or specific industrial executions such as marine-type fans. The motor bearings have a L 10 life. For high temperature applications, three phase motor according to EN 12101-3 in protection class IP55, insulation class H.

Fan performance curves

The performance curves for size 500 to 1250 have been established in installation type - D (according to AMCA 210, ducted inlet and ducted outlet) while installation type A (free inlet and free outlet) is for size 1400 to 2800 and represent the total pressure increase Δp_t as a function of the volume flow. The dynamic pressure p_{dz} refers to the outlet area of the fan.

Sound levels

The ascertaining of sound level follows the Reverberant Room Method according to AMCA 300. The A-weighted inlet sound power levels L_{wiA} or outlet sound power levels L_{woA} are shown on the performance curves.

Belt driven design

Belt driven fan with single / dual motors can be mounted in various positions to suit the actual site condition. Belt driven fans are used for applications to extract more heavily polluted air i.e. presence of corrosive or hazardous fumes, or dirt-laden, moist air or hot air. Various mounting positions are illustrated.

Ordering designations

When ordering, please provide the following information:

- › Fan type
- › Fan code and type
- › Quantity required
- › Duty required at standard air and temperature (air volume in m³/h at static pressure in Pa).
- › Motor power rating in kW
- › Electrical supply
- › Ancillaries required

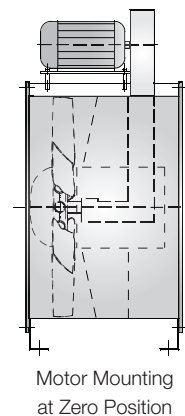
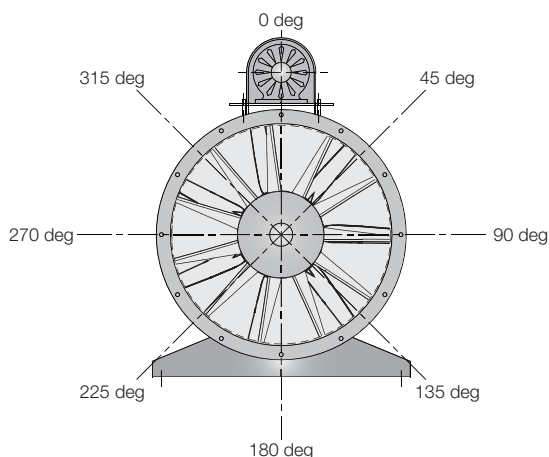

Motor Mounting Position - Specify in degree

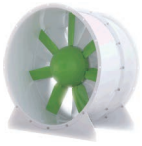

AXV-F

Fan selection and installation

Fan selection

Please select fans according to the nearest performance curve above the required duty point. The middle range of each fan curve is the area of highest efficiency. Do not select fans at the upper end of the fan curve, as this might cause the fan to work in stall. In order to avoid motor overloading, please select motors according to the peak power of the respective performance curve. Please refer to the selection example on the following page.

Fan installation

When installing the fan, please consider the following instructions:

► Fans with free inlet and outlet should be installed with an unobstructed distance of at least 1,5 x fan diameter on suction and pressure sides. Fans should have a bellmouth on the inlet side in order to assure optimal incoming flow. A diffusor mounted on the pressure side will increase efficiency.

► When installing fans in a ducted system, adequate distance to other structural parts such as bends, filters and silencers should be provided for. A sharp bend radius of the duct near the suction or pressure side of the fan is to be avoided. Flexible connections are to be installed in a way that does not obstruct the outlet cross section of the fan (see following page).

Forms of running

Wolter axial flow fans are available for all forms of running. The chart below shows all standard forms of running. Please indicate the required configuration when ordering. Arrows outside the fan casing indicates the correct direction of rotation and airflow.

Form S, SU and SO are not licensed by AMCA International.

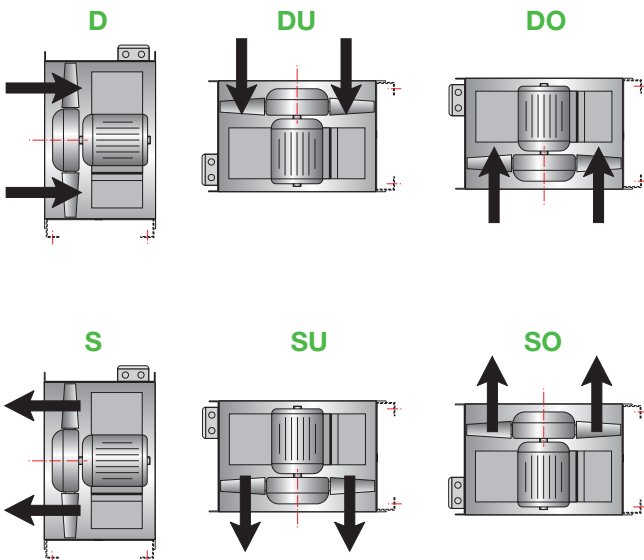
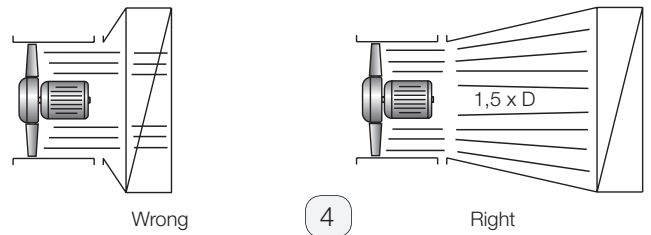
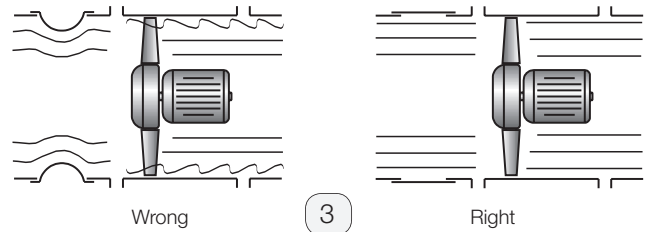
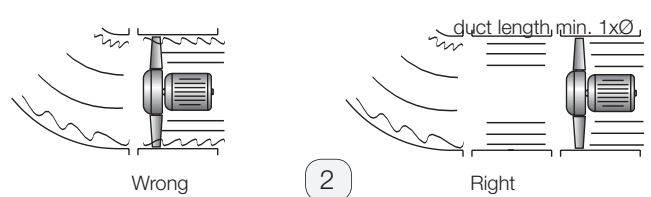
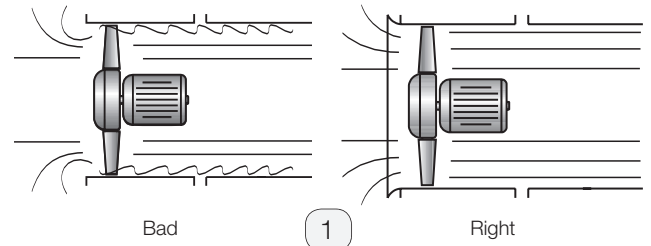

Selection example

Required duty point

- Volume flow: 50000 m³/h
- Static pressure: 735 Pa

In order to calculate the total pressure, please add velocity pressure to static pressure (185 Pa dynamic pressure + 735 Pa static pressure = 920 Pa total pressure)

- Fan speed: 1.500 1/min (4-pole)

Using the fan curve

Having chosen a fan with adequate performance range for the required duty point, plot volume flow and pressure.

At the point of intersection, the following data can be read:

- Motor speed or number of poles 1.500 1/min - 4-pole
- Pitch angle: 30 degrees
- Absorbed power: 19,30 kW
- Sound Power Level: 114 dBA

Calculation of motor power

There are two possibilities to calculate the motor power:

- Calculation of absorbed power by using the fan curve in duty point: 19,30 kW

Motor power: 22 kW

- Calculation according to peak absorbed power, see table below the fan curve: 19,49 kW

Motor power: 22 kW

The given peak absorbed power is the maximum shaft absorbed power over the whole pitch angle curve in.

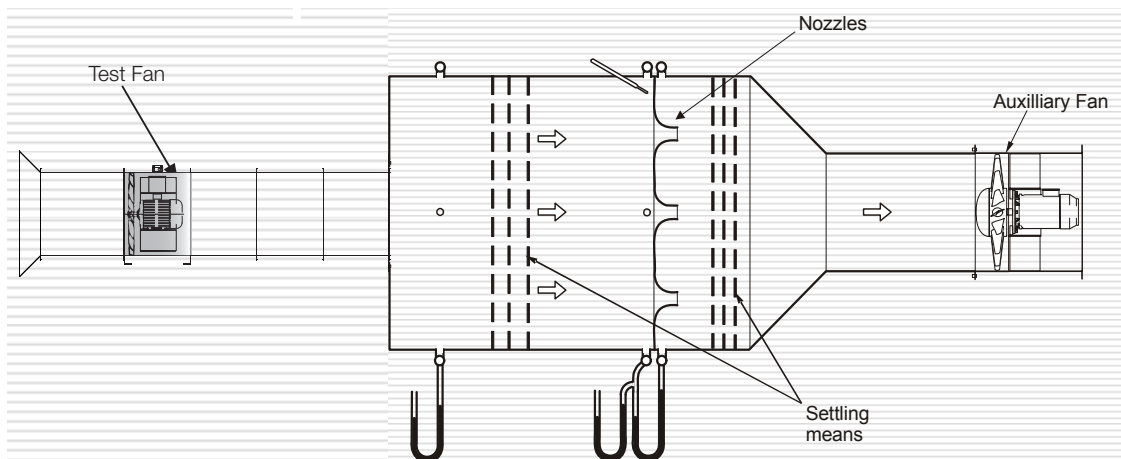
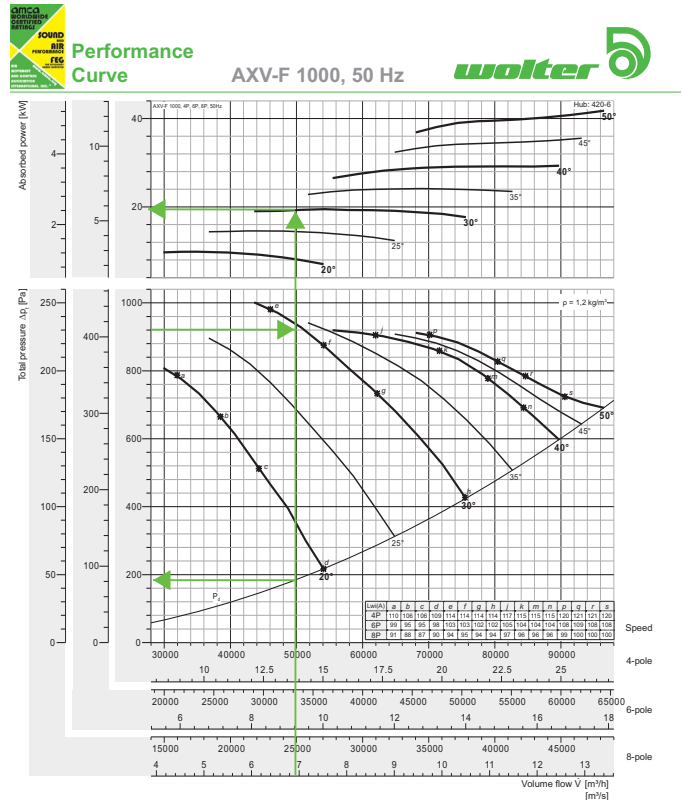

AMCA 210 Figure 12
ISO 5801 Figure 73b

AMCA - FEG rating

Fan Efficiency Grade: AXV-F



Certified FEGs are determined in accordance with AMCA 205 Energy Efficiency Classification for fans. In conjunction with AMCA 211 Certified Ratings Program, Product Rating Manual for Fan Air Performance. This classification is based on total peak, or optimum, fan efficiency for a given fan speed, impeller diameter and test application category (test configuration). For the purpose of energy classification, the peak efficiency shall be determined at a speed that is lower than the fan's maximum design speed.

The AMCA Certified Ratings Seal applies to the Fan Efficiency Grade (FEG) for AXV-F series Axial Fan model AXV-F 500 to AXV-F 2800 as shown in the table below.

Fan Model No.	Fan Speed (rpm)	Fan Outlet Area (m2)	Fan Efficiency Grades	Fan Model No.	Fan Speed (rpm)	Fan Outlet Area (m2)	Fan Efficiency Grade
AXV-F 500-150-6	3000/1500/1000	0,1987	FEG 80	AXV-F 1400-550-7	1500/1000/750	1,5504	FEG 80
AXV-F 560-168-6	3000/1500/1000	0,2507	FEG 75	AXV-F 1600-625-7	1500/1000/750	2,0232	FEG 80
AXV-F 630-200-6	3000/1500/1000	0,3157	FEG 75	AXV-F 1800-710-7	1000/750/600	2,5588	FEG 80
AXV-F 710-212-6	3000/1500/1000	0,3970	FEG 75	AXV-F 2000-785-7	1000/750/600	3,1573	FEG 80
AXV-F 800-238-6	1500/1000/750	0,4989	FEG 75	AXV-F 2200-862-7	750/600/500	3,8186	FEG 80
AXV-F 900-267-6	1500/1000/750	0,6277	FEG 75	AXV-F 2400-942-7	750/600/500	4,5428	FEG 80
AXV-F 1000-420-6	1500/1000/750	0,7901	FEG 75	AXV-F 2500-980-7	750/600/500	4,9284	FEG 80
AXV-F 1120-472-6	1500/1000/750	0,9940	FEG 75	AXV-F 2600-1020-7	750/600/500	5,3297	FEG 80
AXV-F 1250-525-6	1500/1000/750	1,2272	FEG 75	AXV-F 2800-1095-7	750/600/500	6,1795	FEG 80

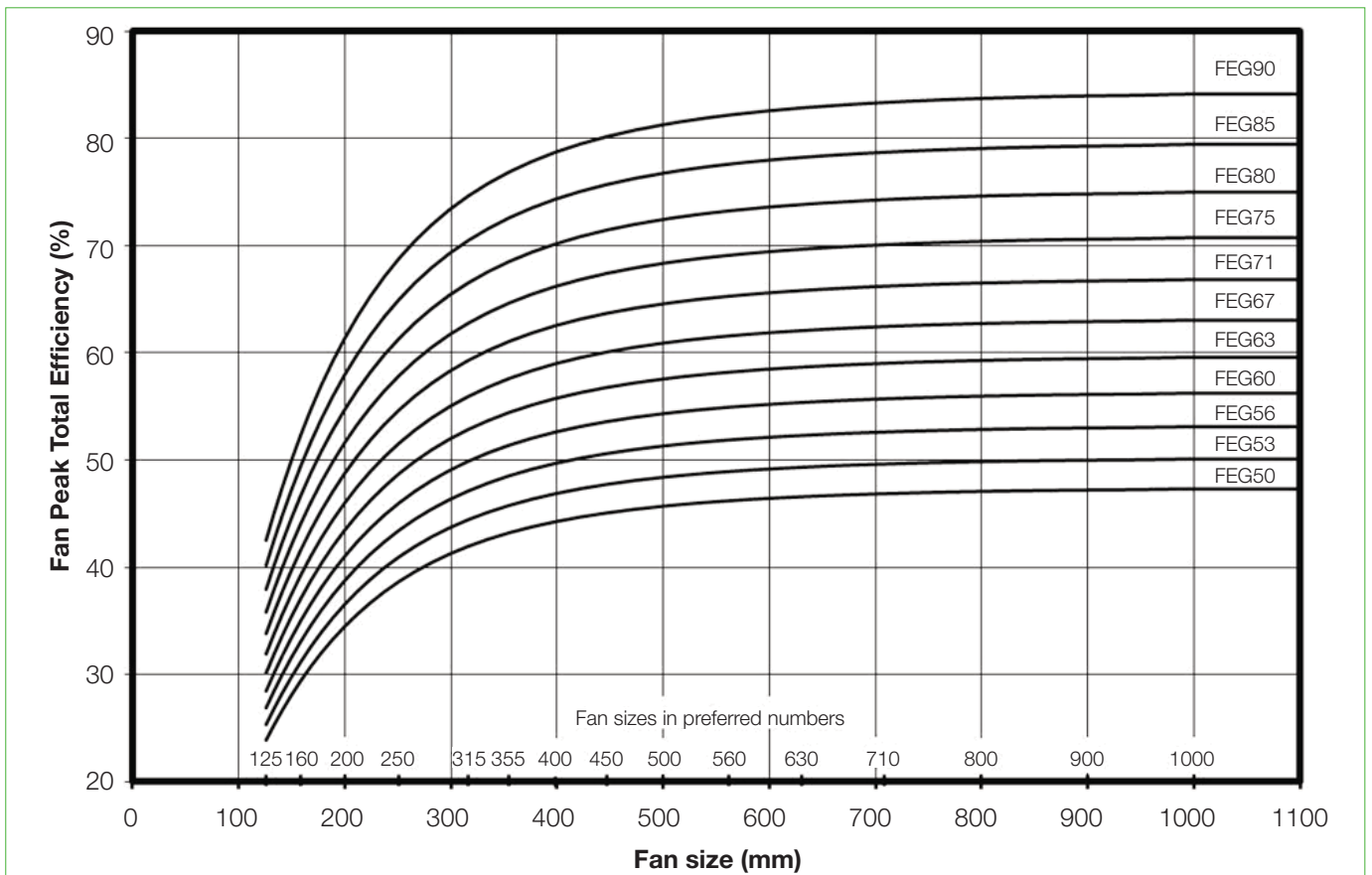



Performance Curve

AXV-F 500-150-6, 50 Hz

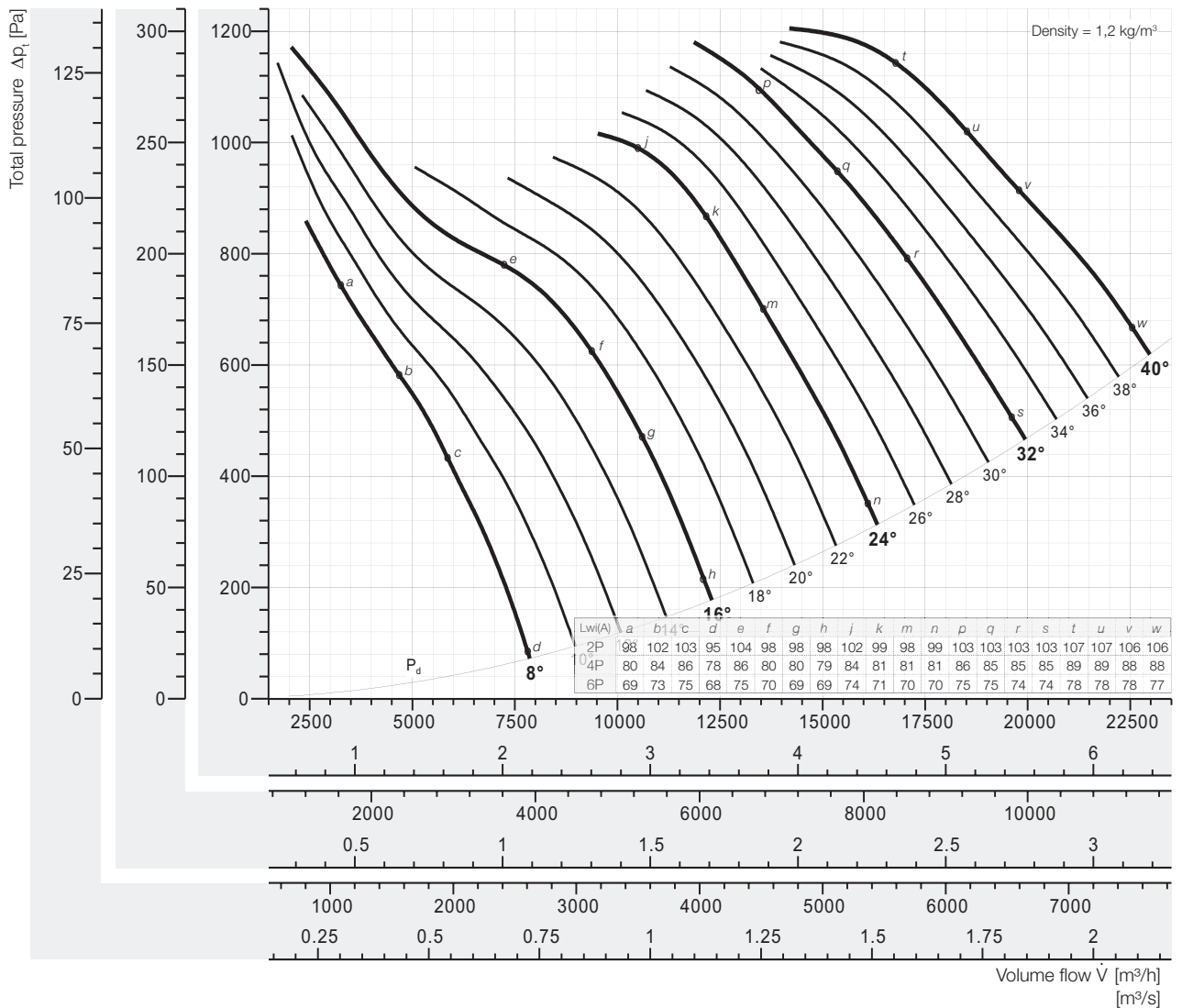
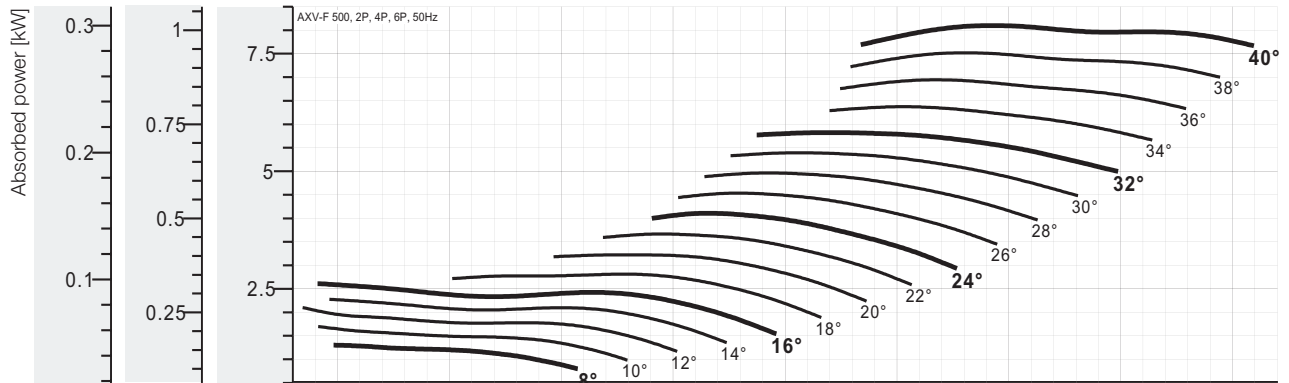

Speed
2-pole
4-pole
6-pole

Peak absorbed power [kW]

2-pole = 3000 rpm; 4-pole = 1500 rpm; 6-pole = 1000 rpm;

N Poles	Pitch angle [°]																
	8	10	12	14	16	18	20	22	24	26	28	30	32	34	36	38	40
2P motor	1,302	1,703	2,103	2,278	2,610	2,812	3,224	3,665	4,108	4,536	4,965	5,395	5,825	6,372	6,946	7,522	8,100
4P motor	0,163	0,213	0,263	0,285	0,326	0,352	0,403	0,458	0,514	0,567	0,621	0,674	0,728	0,797	0,868	0,940	1,012
6P motor	0,048	0,063	0,078	0,084	0,097	0,104	0,119	0,136	0,152	0,168	0,184	0,200	0,216	0,236	0,257	0,279	0,300

Fan test laboratory AMCA 210 Fig.12, Test Chamber. Performance certified is for installation type D - Ducted inlet, Ducted outlet. Performance ratings do not include the effects of appurtenances (accessories-belt cover, pulley & belt). Power rating (kW) does not include transmission losses.

The A-weighted sound ratings shown have been calculated per AMCA International Standard 301. Values shown are for inlet Lw(A) sound power levels for installation Type D: ducted inlet, ducted outlet. Ratings include the effects of duct end correction.



Performance Curve

AXV-F 560-168-6, 50 Hz

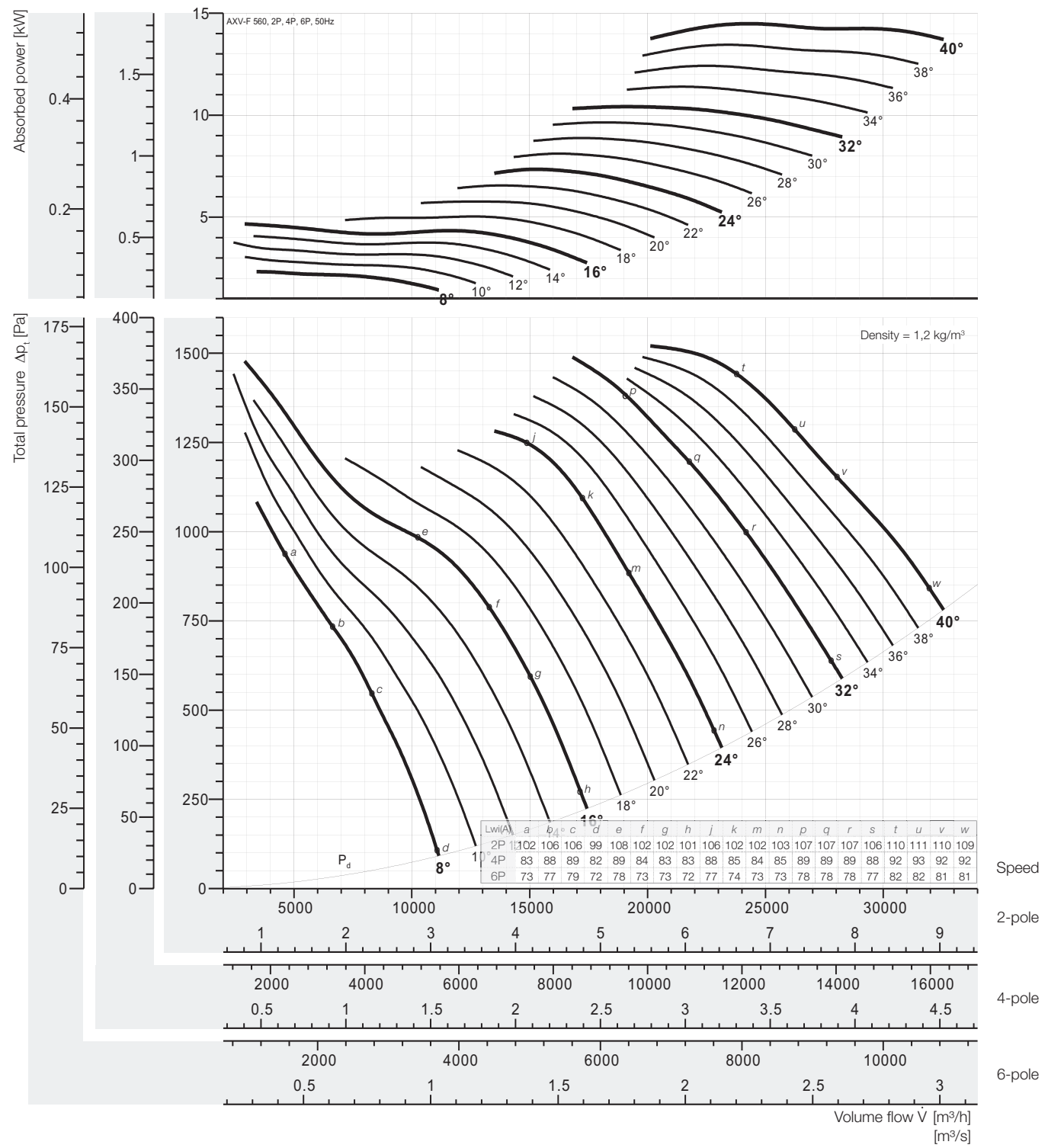

Peak absorbed power [kW]

2-pole = 3000 rpm; 4-pole = 1500 rpm; 6-pole = 1000 rpm;

N Poles	Pitch angle [°]																			
	8	10	12	14	16	18	20	22	24	26	28	30	32	34	36	38	40			
2P motor	2,329	3,045	3,761	4,073	4,667	5,028	5,765	6,553	7,345	8,111	8,878	9,646	10,42	11,39	12,42	13,45	14,48			
	3,0	4,0		5,5		7,5				11				15						
4P motor	0,291	0,381	0,470	0,509	0,583	0,629	0,721	0,819	0,918	1,014	1,110	1,206	1,302	1,424	1,552	1,681	1,810			
	0,37	0,55			0,75		1,1			1,5				2,2						
6P motor	0,086	0,113	0,139	0,151	0,173	0,186	0,214	0,243	0,272	0,300	0,329	0,357	0,386	0,422	0,460	0,498	0,536			
	0,25								0,37				0,55							

Fan test laboratory AMCA 210 Fig.12, Test Chamber. Performance certified is for installation type D - Ducted inlet, Ducted outlet. Performance ratings do not include the effects of appurtenances (accessories-belt cover, pulley & belt). Power rating (kW) does not include transmission losses.

The A-weighted sound ratings shown have been calculated per AMCA International Standard 301. Values shown are for inlet Lw(A) sound power levels for installation Type D: ducted inlet, ducted outlet. Ratings include the effects of duct end correction.



Performance Curve

AXV-F 630-200-6, 50 Hz

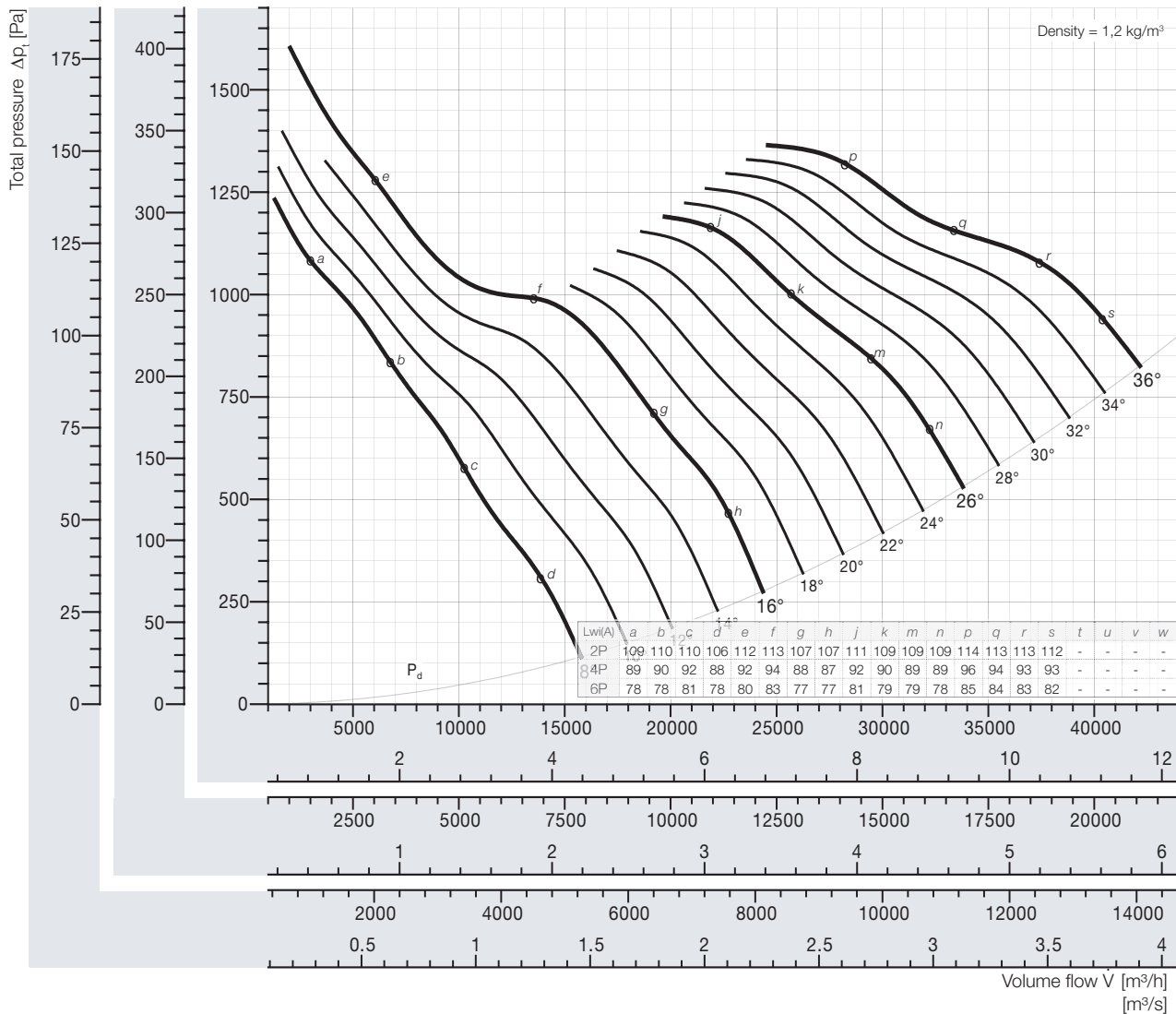
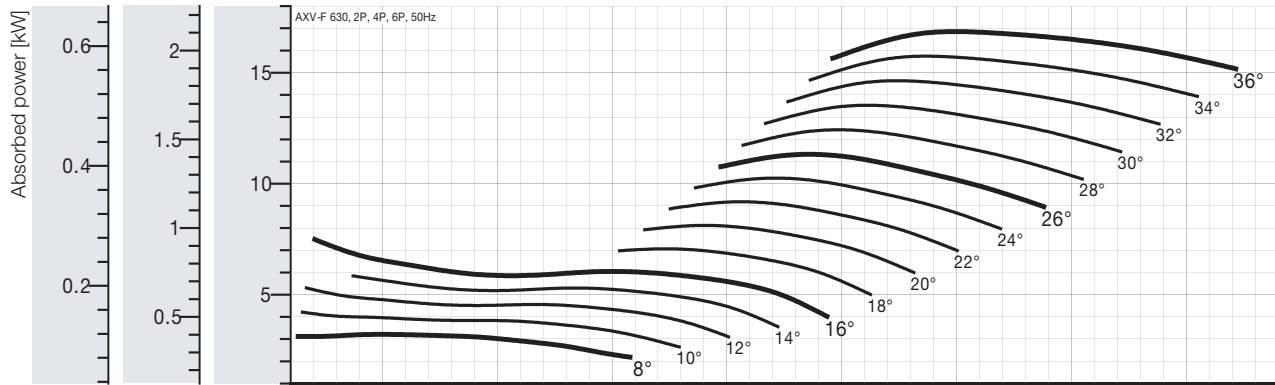

Lw(A)	a	b	c	d	e	f	g	h	j	k	m	n	p	q	r	s	t	u	v	w
2P	109	110	110	106	112	113	107	107	111	109	109	109	114	113	113	112	-	-	-	-
4P	89	90	92	88	92	94	88	87	92	90	89	89	96	94	93	93	-	-	-	-
6P	78	78	81	78	80	83	77	77	81	79	79	78	85	84	83	82	-	-	-	-

Speed
2-pole
4-pole
6-pole

Peak absorbed power [kW]

2-pole = 3000 rpm; 4-pole = 1500 rpm; 6-pole = 1000 rpm;

N Poles	Pitch angle [°]																
	8	10	12	14	16	18	20	22	24	26	28	30	32	34	36	38	40
2P motor	3,211	4,214	5,306	6,398	6,754	7,062	8,121	9,181	10,24	11,30	12,40	13,51	14,62	15,73	16,84	-	-
4P motor	0,401	0,527	0,663	0,800	0,844	0,883	1,015	1,148	1,280	1,412	1,550	1,689	1,828	1,967	2,105	-	-
6P motor	0,119	0,156	0,197	0,237	0,250	0,262	0,301	0,340	0,379	0,419	0,459	0,500	0,542	0,583	0,624	-	-

Fan test laboratory AMCA 210 Fig.12, Test Chamber. Performance certified is for installation type D - Ducted inlet, Ducted outlet. Performance ratings do not include the effects of appurtenances (accessories-belt cover, pulley & belt). Power rating (kW) does not include transmission losses.

The A-weighted sound ratings shown have been calculated per AMCA International Standard 301. Values shown are for inlet Lw(A) sound power levels for installation Type D: ducted inlet, ducted outlet. Ratings include the effects of duct end correction.



Performance Curve

AXV-F 710-212-6, 50 Hz

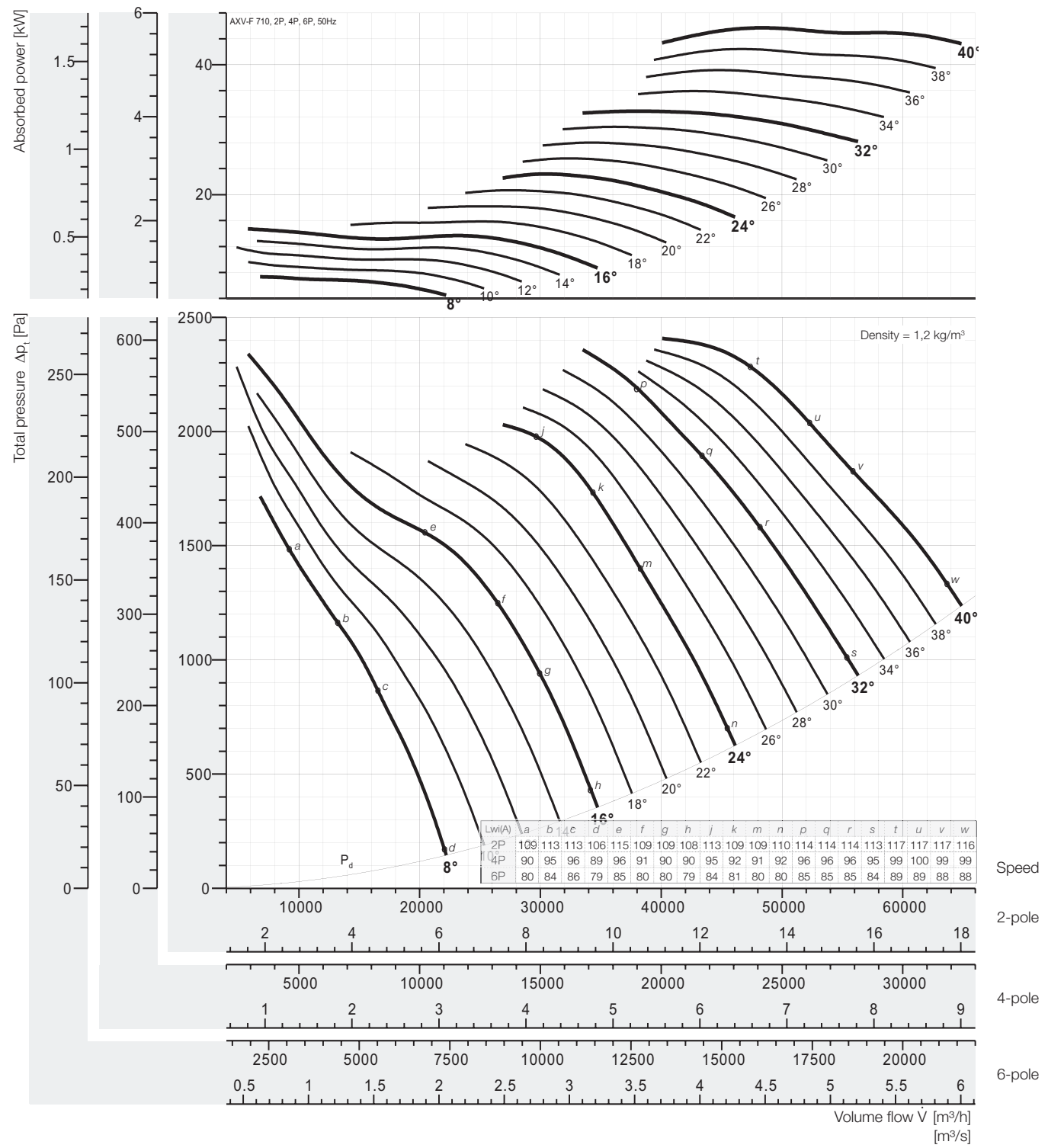

Peak absorbed power [kW]

2-pole = 3000 rpm; 4-pole = 1500 rpm; 6-pole = 1000 rpm;

N Poles	Pitch angle [°]																
	8	10	12	14	16	18	20	22	24	26	28	30	32	34	36	38	40
2P motor	7,347	9,606	11,86	12,85	14,73	15,86	18,19	20,67	23,17	25,59	28,01	30,43	32,86	35,95	39,18	42,43	45,69
4P motor	0,918	1,201	1,483	1,606	1,841	1,983	2,274	2,584	2,897	3,199	3,501	3,804	4,107	4,494	4,898	5,304	5,711
6P motor	0,272	0,356	0,439	0,476	0,545	0,588	0,674	0,766	0,858	0,948	1,037	1,127	1,217	1,331	1,451	1,572	1,692

Fan test laboratory AMCA 210 Fig.12, Test Chamber. Performance certified is for installation type D - Ducted inlet, Ducted outlet. Performance ratings do not include the effects of appurtenances (accessories-belt cover, pulley & belt). Power rating (kW) does not include transmission losses.

The A-weighted sound ratings shown have been calculated per AMCA International Standard 301. Values shown are for inlet Lw(A) sound power levels for installation Type D: ducted inlet, ducted outlet. Ratings include the effects of duct end correction.



Performance Curve

AXV-F 800-238-6, 50 Hz

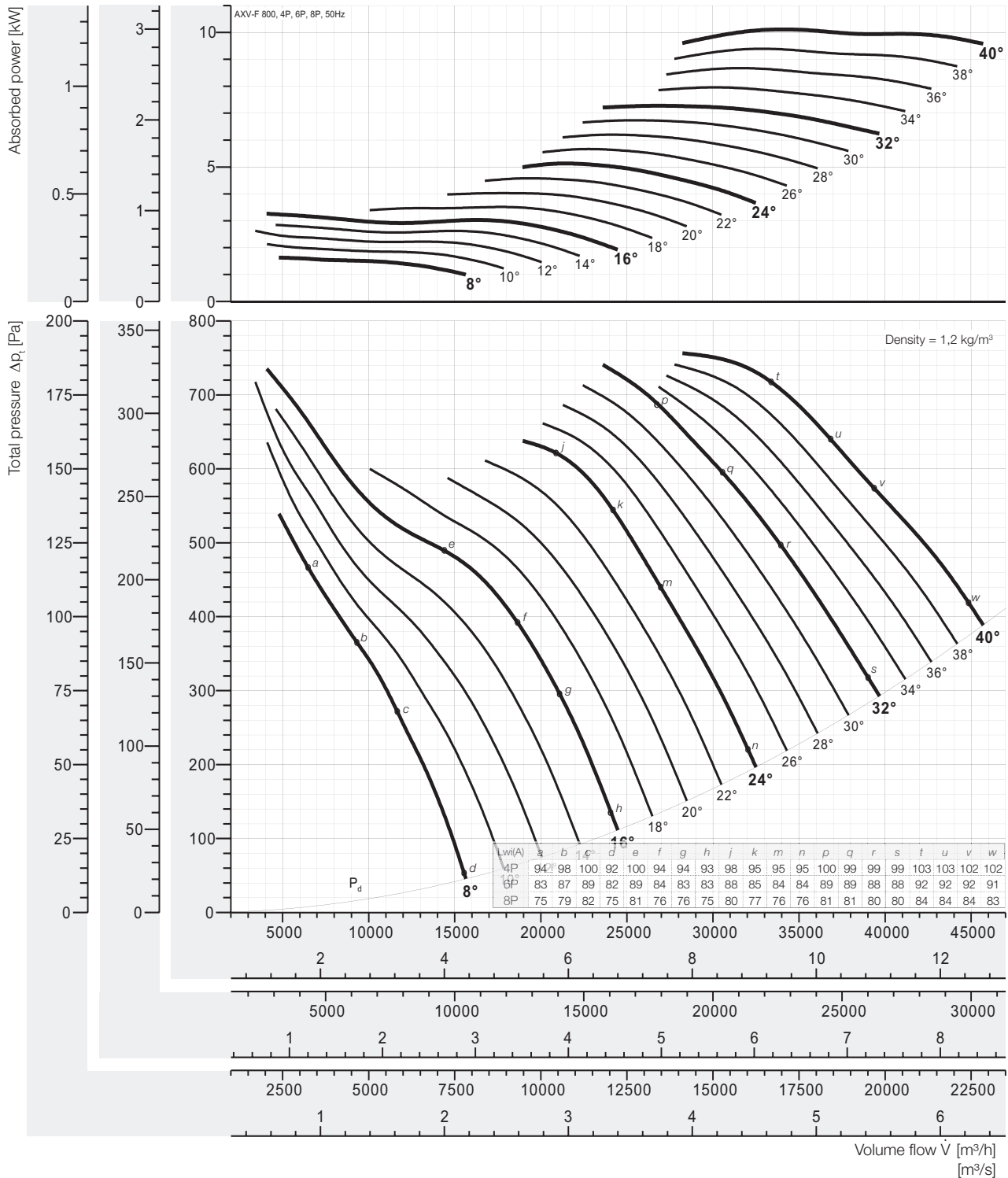

Speed
4-pole
6-pole
8-pole

Peak absorbed power [kW]

4-pole = 1500 rpm; 6-pole = 1000 rpm; 8-pole = 750 rpm;

N Poles	Pitch angle [°]																			
	8	10	12	14	16	18	20	22	24	26	28	30	32	34	36	38	40			
4P motor	1,626	2,126	2,626	2,844	3,260	3,512	4,026	4,576	5,130	5,665	6,200	6,737	7,274	7,957	8,673	9,393	10,11			
6P motor	0,482	0,630	0,778	0,843	0,966	1,040	1,193	1,356	1,520	1,678	1,837	1,996	2,155	2,358	2,570	2,783	2,997			
8P motor	0,203	0,266	0,328	0,356	0,407	0,439	0,503	0,572	0,641	0,708	0,775	0,842	0,909	0,995	1,084	1,174	1,264			

Fan test laboratory AMCA 210 Fig.12, Test Chamber. Performance certified is for installation type D - Ducted inlet, Ducted outlet. Performance ratings do not include the effects of appurtenances (accessories-belt cover, pulley & belt). Power rating (kW) does not include transmission losses.

The A-weighted sound ratings shown have been calculated per AMCA International Standard 301. Values shown are for inlet Lw(A) sound power levels for installation Type D: ducted inlet, ducted outlet. Ratings include the effects of duct end correction.



Performance Curve

AXV-F 900, 4P, 6P, 8P, 50 Hz

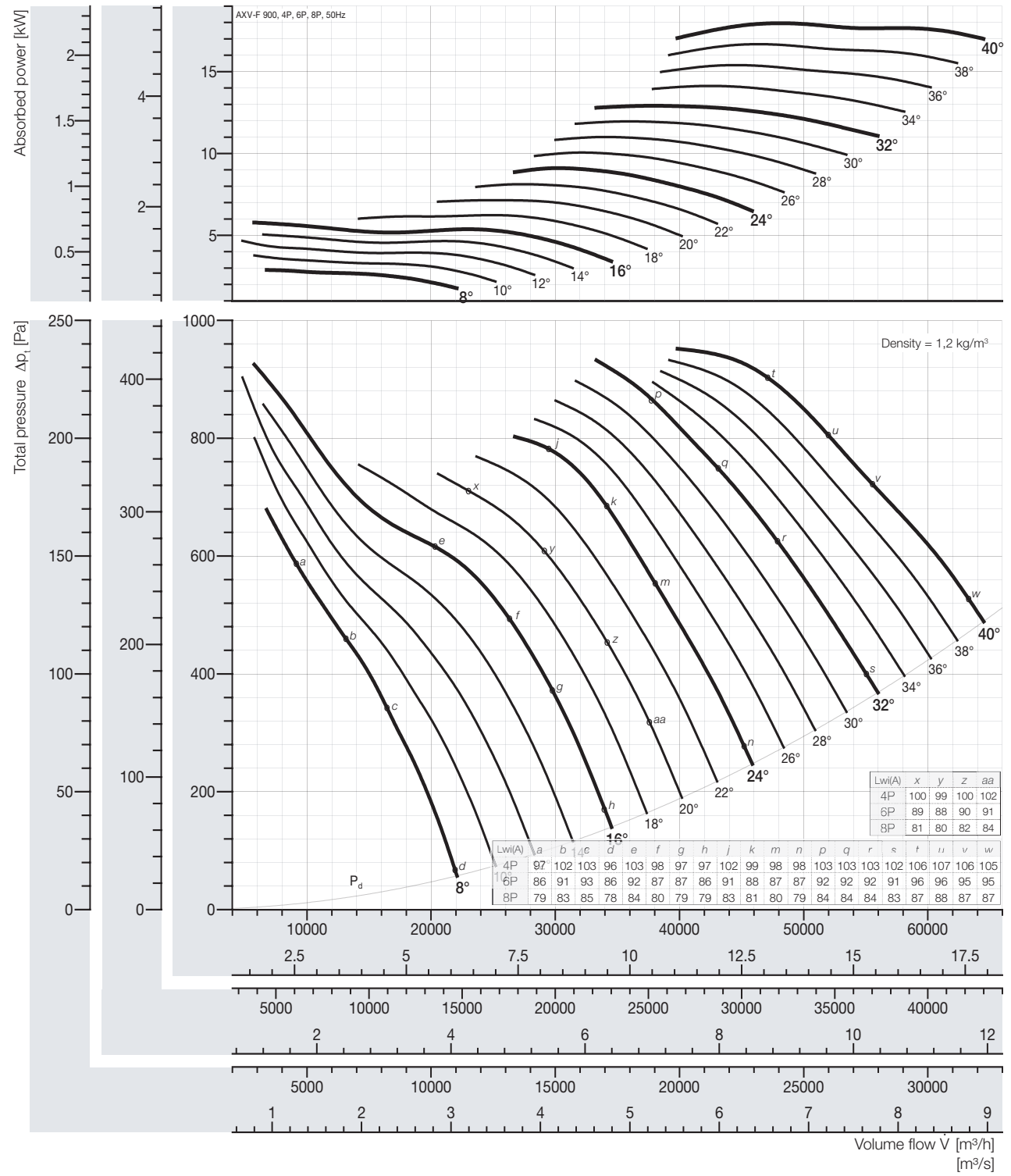

Peak absorbed power [kW]

4-pole = 1500 rpm; 6-pole = 1000 rpm; 8-pole = 750 rpm;

N Poles	Pitch angle [°]																
	8	10	12	14	16	18	20	22	24	26	28	30	32	34	36	38	40
4P motor	2,888	3,775	4,663	5,050	5,787	6,235	7,149	8,125	9,108	10,06	11,00	11,96	12,91	14,13	15,40	16,68	17,96
6P motor	0,856	1,119	1,382	1,496	1,715	1,847	2,118	2,407	2,699	2,980	3,262	3,544	3,826	4,186	4,563	4,941	5,321
8P motor	0,361	0,472	0,583	0,631	0,723	0,779	0,894	1,016	1,138	1,257	1,376	1,495	1,614	1,766	1,925	2,085	2,245

Fan test laboratory AMCA 210 Fig.12, Test Chamber. Performance certified is for installation type D - Ducted inlet, Ducted outlet. Performance ratings do not include the effects of appurtenances (accessories-belt cover, pulley & belt). Power rating (kW) does not include transmission losses.

The A-weighted sound ratings shown have been calculated per AMCA International Standard 301. Values shown are for inlet Lw(A) sound power levels for installation Type D: ducted inlet, ducted outlet. Ratings include the effects of duct end correction.



Performance Curve

AXV-F 1000-420-6, 50 Hz *wolter*

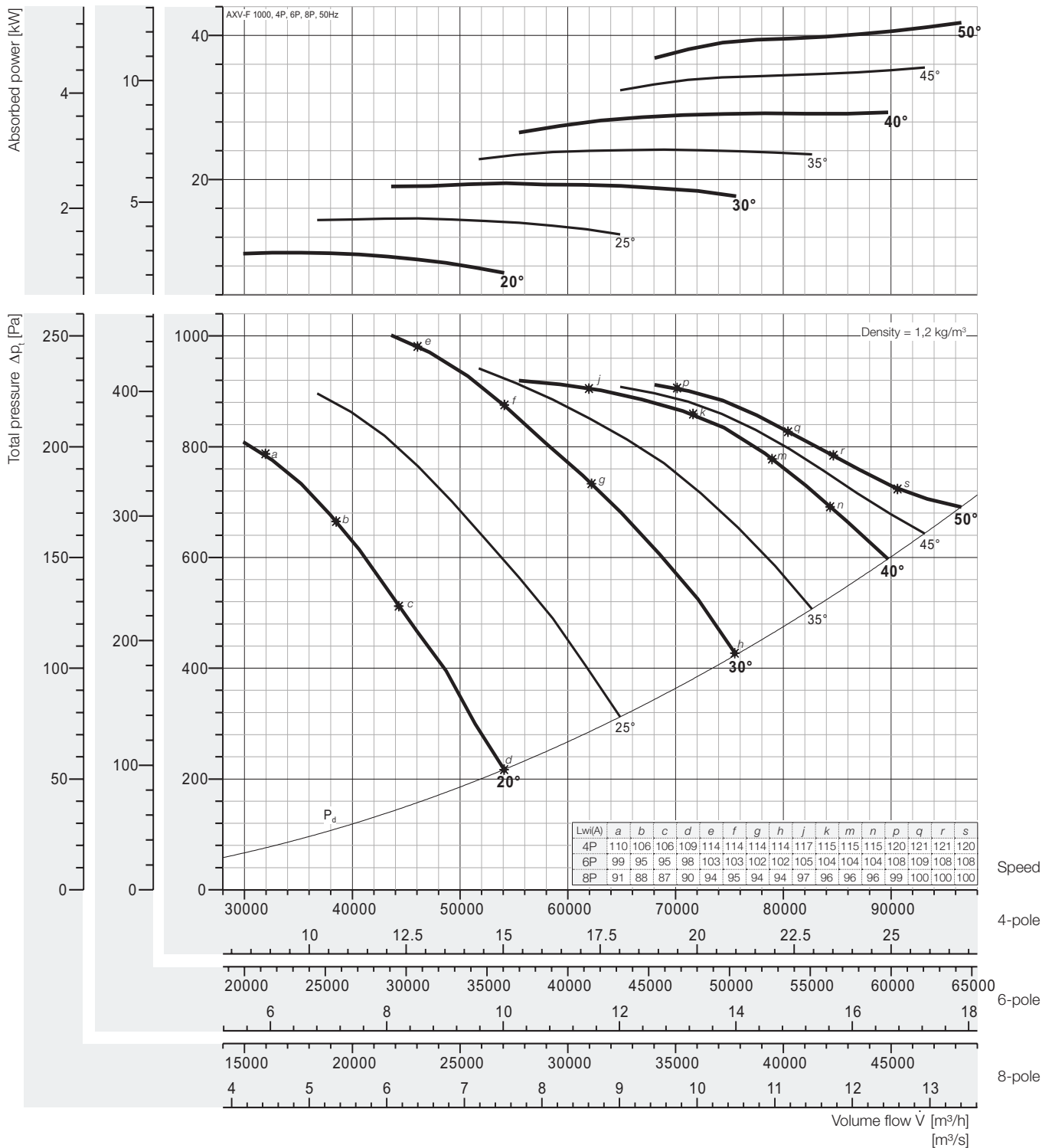

Peak absorbed power [kW]

4-pole = 1500 rpm; 6-pole = 1000 rpm; 8-pole = 750 rpm;

N Poles	Pitch angle [°]						
	20	25	30	35	40	45	50
4P motor	9,853	14,61	19,49	24,16	29,32	35,55	41,77
6P motor	2,919	4,330	5,776	7,159	8,688	10,53	12,38
8P motor	1,232	1,827	2,437	3,020	3,665	4,443	5,222

Fan test laboratory AMCA 210 Fig.12, Test Chamber. Performance certified is for installation type D - Ducted inlet, Ducted outlet. Performance ratings do not include the effects of appurtenances (accessories-belt cover, pulley & belt). Power rating (kW) does not include transmission losses.

The A-weighted sound ratings shown have been calculated per AMCA International Standard 301. Values shown are for inlet LwA sound power levels for installation Type D: ducted inlet, ducted outlet. Ratings include the effects of duct end correction.



Performance Curve

AXV-F 1120-472-6, 50 Hz

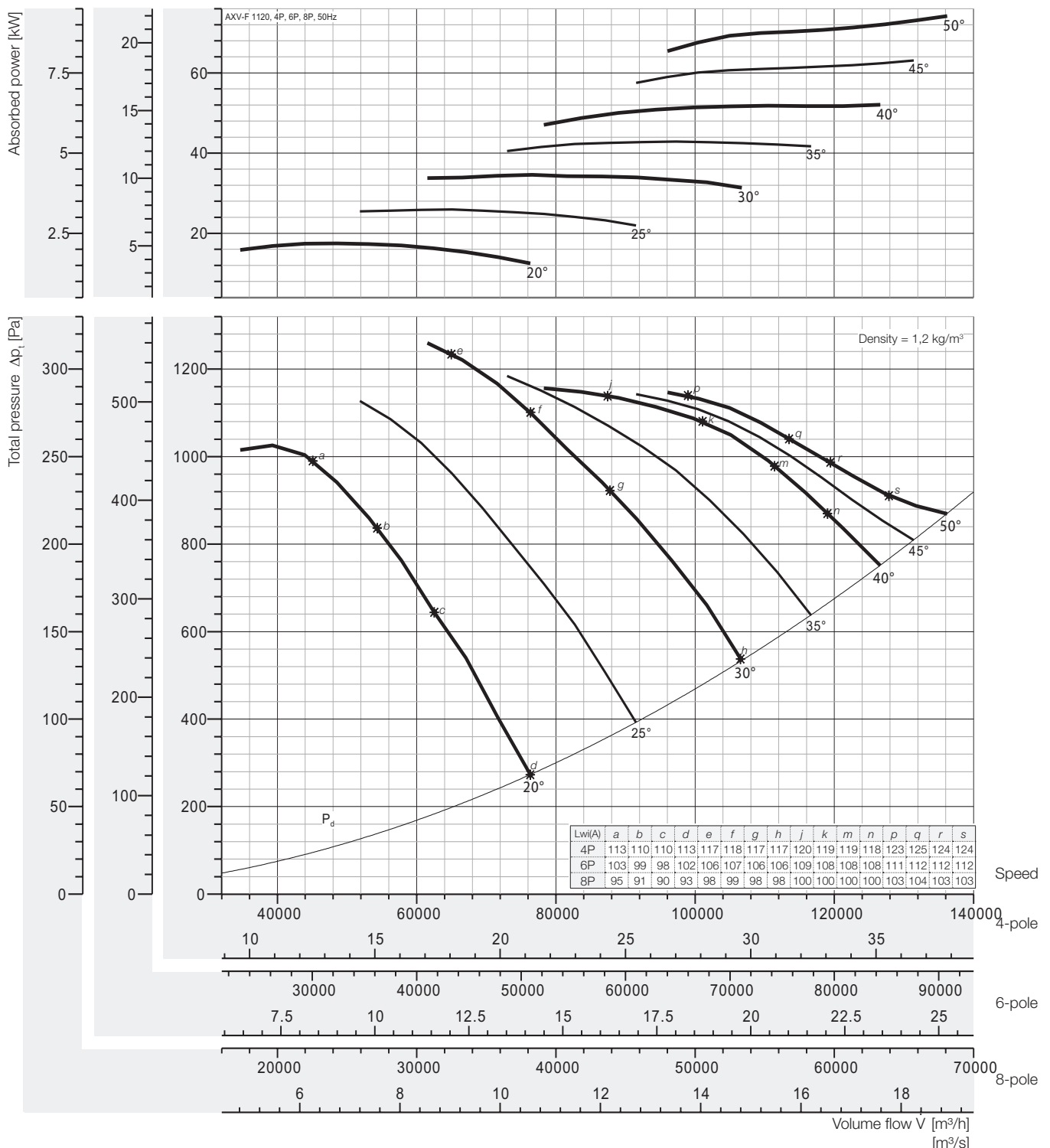

Peak absorbed power [kW]

4-pole = 1500 rpm; 6-pole = 1000 rpm; 8-pole = 750 rpm;

N Poles	Pitch angle [°]						
	20	25	30	35	40	45	50
4P motor	17,51	25,94	34,60	42,89	52,05	63,11	74,16
	18,5	30	37	45	55	75	
6P motor	5,187	7,686	10,25	12,71	15,42	18,70	21,97
	5,5	11		15	18,5	22	
8P motor	2,188	3,243	4,326	5,361	6,506	7,888	9,270
	2,2	4	5,5		7,5	11	

Fan test laboratory AMCA 210 Fig.12, Test Chamber. Performance certified is for installation type D - Ducted inlet, Ducted outlet. Performance ratings do not include the effects of appurtenances (accessories-belt cover, pulley & belt). Power rating (kW) does not include transmission losses.

The A-weighted sound ratings shown have been calculated per AMCA International Standard 301. Values shown are for inlet Lw(A) sound power levels for installation Type D: ducted inlet, ducted outlet. Ratings include the effects of duct end correction.



Performance Curve

AXV-F 1250-525-6, 50 Hz *wolter*

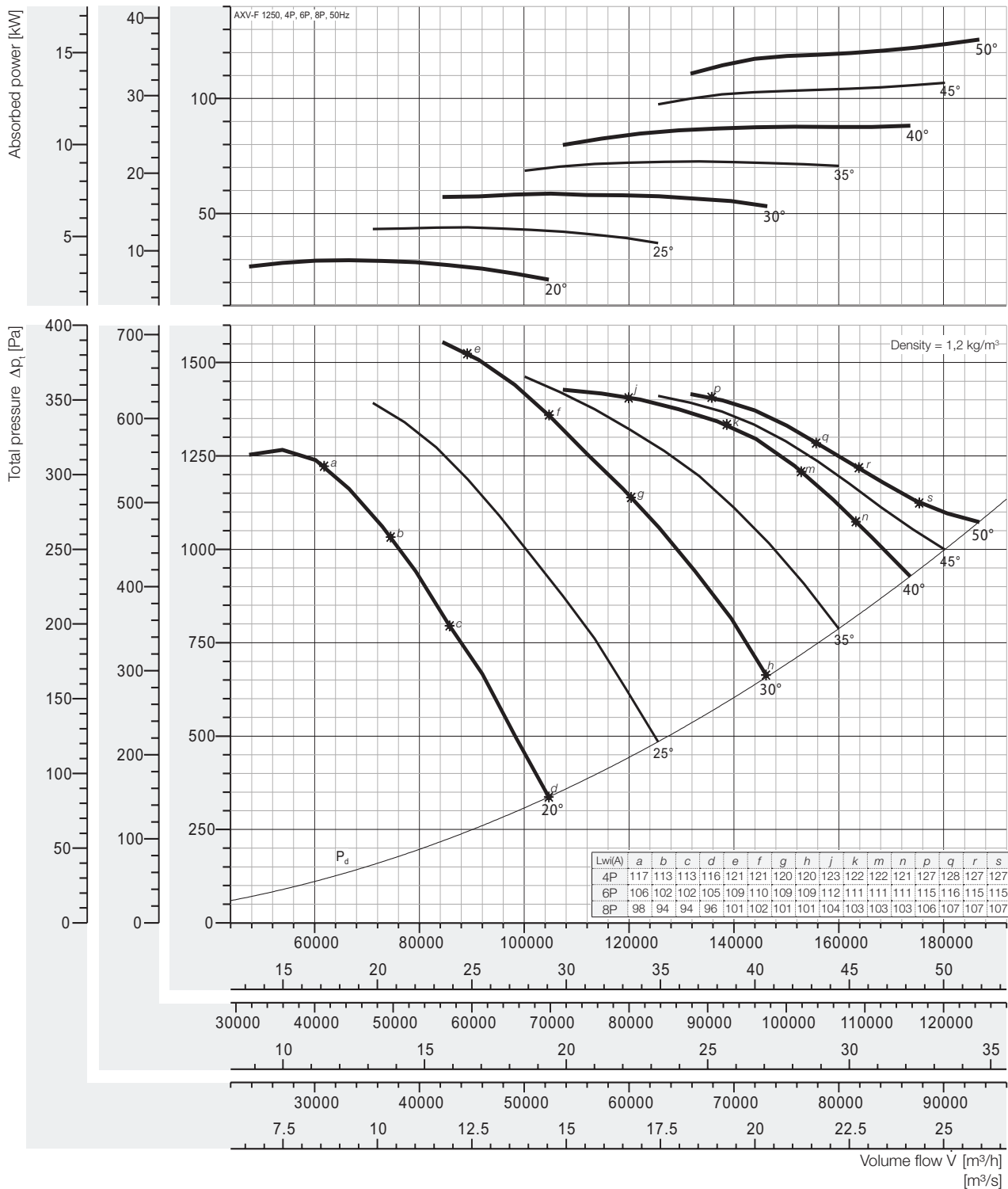

Peak absorbed power [kW]

4-pole = 1500 rpm; 6-pole = 1000 rpm; 8-pole = 750 rpm;

N Poles	Pitch angle [°]						
	20	25	30	35	40	45	50
4P motor	29,65	43,93	58,60	72,64	88,15	106,9	125,6
6P motor	8,78	13,02	17,36	21,52	26,12	31,66	37,21
8P motor	3,706	5,492	7,325	9,080	11,02	13,36	15,70

Fan test laboratory AMCA 210 Fig.12, Test Chamber. Performance certified is for installation type D - Ducted inlet, Ducted outlet. Performance ratings do not include the effects of appurtenances (accessories-belt cover, pulley & belt). Power rating (kW) does not include transmission losses.

The A-weighted sound ratings shown have been calculated per AMCA International Standard 301. Values shown are for inlet Lw(A) sound power levels for installation Type D: ducted inlet, ducted outlet. Ratings include the effects of duct end correction.



Performance Curve

AXV-F 1400-550-7, 50 Hz

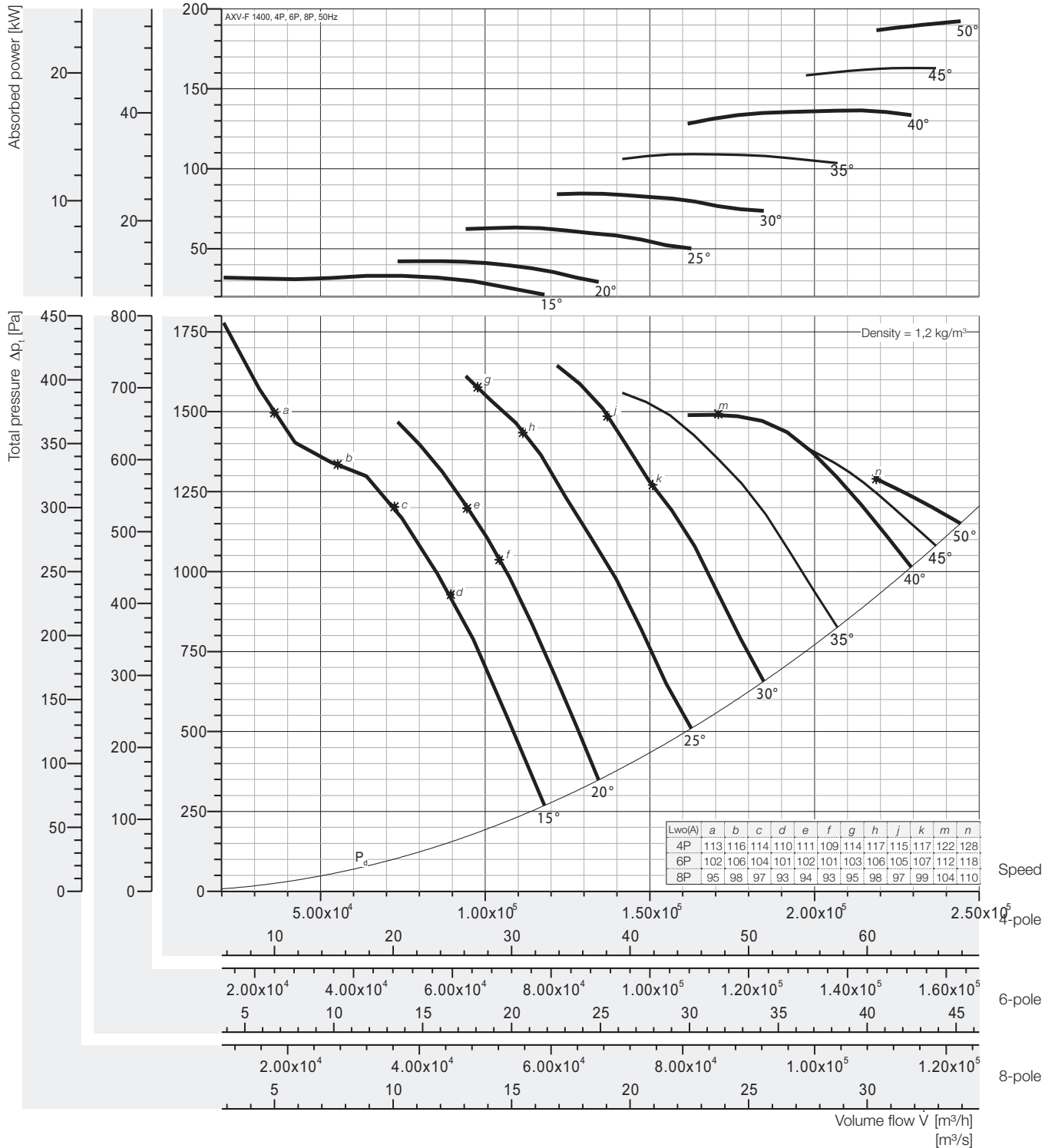

Peak absorbed power [kW]

4-pole = 1500 rpm; 6-pole = 1000 rpm; 8-pole = 750 rpm;

N Poles	Pitch angle [°]							
	15	20	25	30	35	40	45	50
4P motor	33,14	42,28	63,27	84,50	109,2	136,5	163,1	192,3
6P motor	9,819	12,53	18,75	25,04	32,36	40,45	48,32	56,98
8P motor	4,142	5,285	7,908	10,56	13,65	17,06	20,38	24,04

Fan test laboratory AMCA 210 Fig.15, Test Chamber. Performance certified is for installation type A - Free inlet, Free outlet with partition. Performance ratings do not include the effects of appurtenances (accessories-belt cover, pulley & belt). Power rating (kW) does not include transmission losses.

The A-weighted sound ratings shown have been calculated per AMCA International Standard 301. Values shown are for outlet LwoA sound power levels for installation Type A: free inlet, free outlet.



Performance Curve

AXV-F 1600-625-7, 50 Hz *wolter*

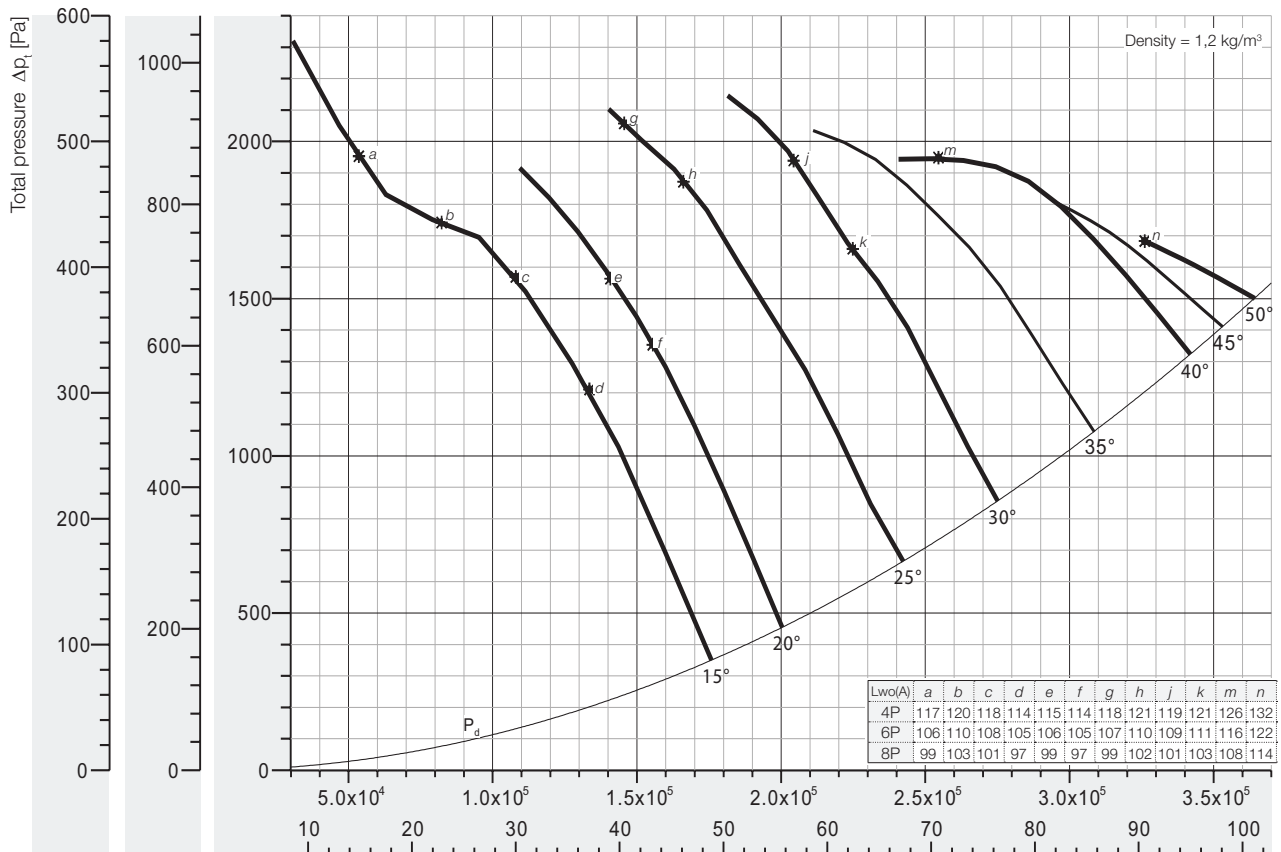
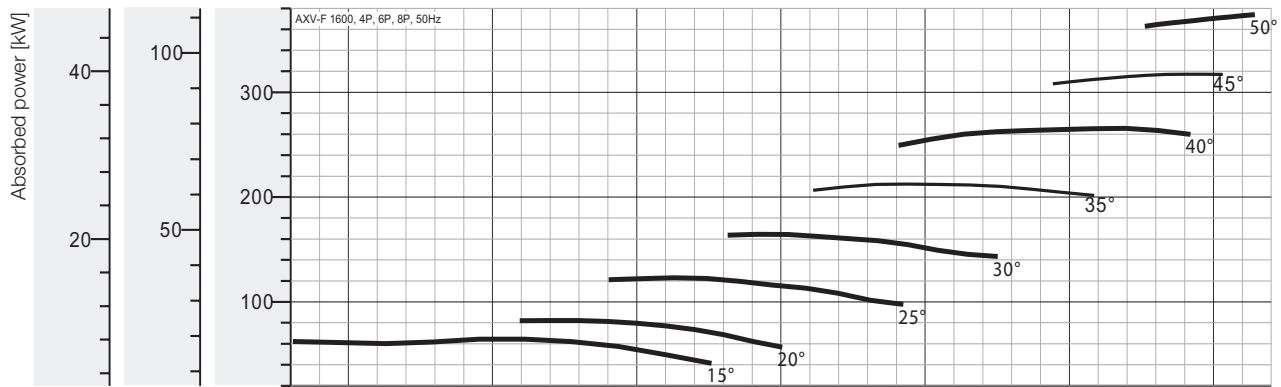

Lwo(A)	a	b	c	d	e	f	g	h	j	k	m	n
4P	117	120	118	114	115	114	118	121	119	121	126	132
6P	106	110	108	105	106	105	107	110	109	111	116	122
8P	99	103	101	97	99	97	99	102	101	103	108	114

Speed
4-pole
6-pole
8-pole

Peak absorbed power [kW]

4-pole = 1500 rpm; 6-pole = 1000 rpm; 8-pole = 750 rpm;

N Poles	Pitch angle [°]							
	15	20	25	30	35	40	45	50
4P motor	64,46	82,25	123,1	164,4	212,4	265,6	317,2	374,1
6P motor	19,10	24,37	36,47	48,71	62,94	78,68	93,99	110,8
8P motor	8,058	10,28	15,38	20,55	26,55	33,19	39,65	46,76

Fan test laboratory AMCA 210 Fig.15, Test Chamber. Performance certified is for installation type A - Free inlet, Free outlet with partition. Performance ratings do not include the effects of appurtenances (accessories-belt cover, pulley & belt). Power rating (kW) does not include transmission losses.

The A-weighted sound ratings shown have been calculated per AMCA International Standard 301. Values shown are for outlet LwoA sound power levels for installation Type A: free inlet, free outlet.



Performance Curve

AXV-F 1800-710-7, 50 Hz

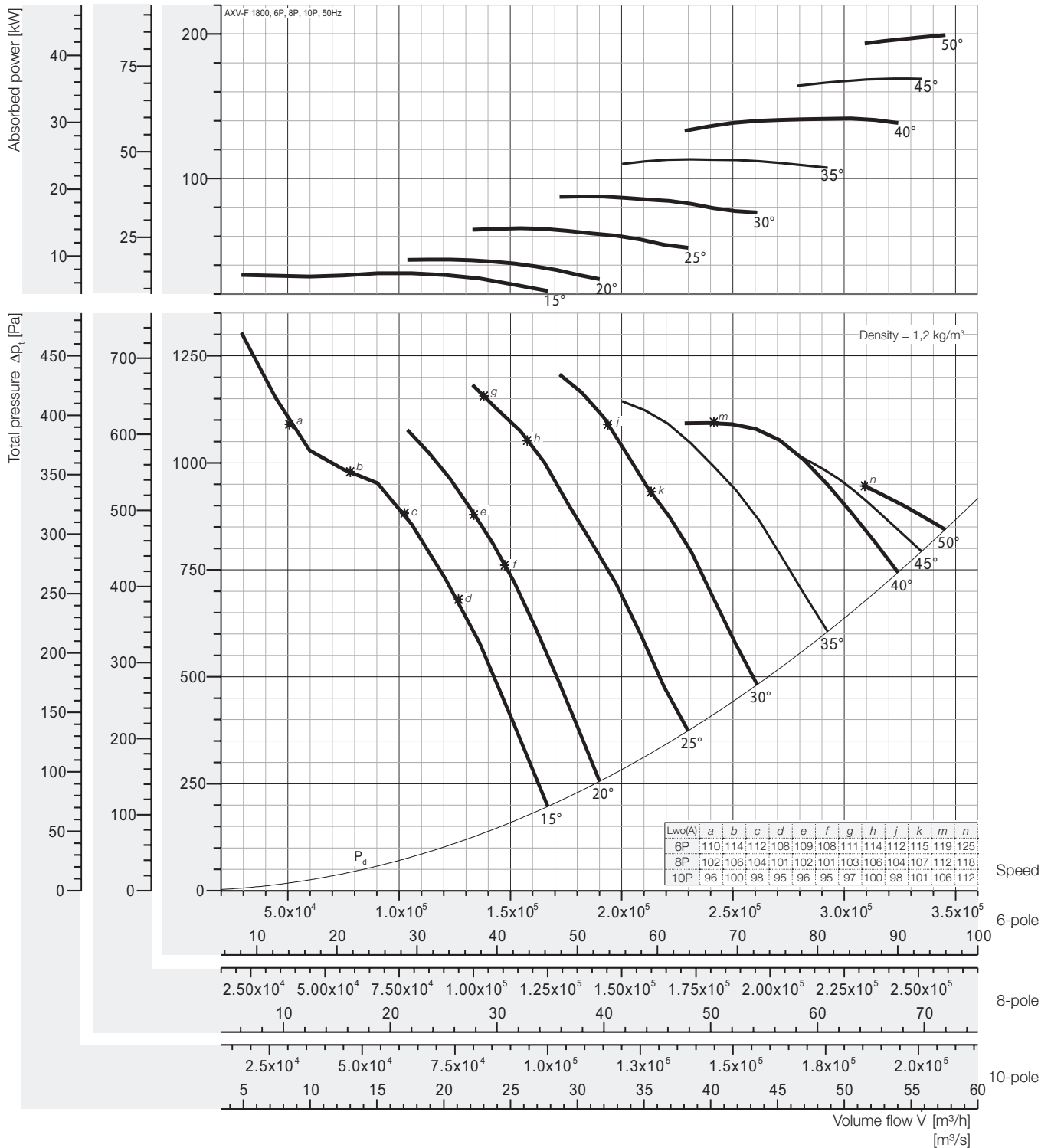

Peak absorbed power [kW]

6-pole = 1000 rpm; 8-pole = 750 rpm; 10-pole = 600 rpm;

N Poles	Pitch angle [°]							
	15	20	25	30	35	40	45	50
6P motor	34,36	43,84	65,60	87,62	113,2	141,5	169,1	199,4
	37	45	75	90	132	160	200	
8P motor	14,50	18,49	27,68	36,96	47,77	59,71	71,33	84,12
	15	18,5	30	37	55	75	90	
10P motor	7,422	9,470	14,17	18,93	24,46	30,57	36,52	43,07
	7,5	11	15	22	30	37	45	

Fan test laboratory AMCA 210 Fig.15, Test Chamber. Performance certified is for installation type A - Free inlet, Free outlet with partition. Performance ratings do not include the effects of appurtenances (accessories-belt cover, pulley & belt). Power rating (kW) does not include transmission losses.

The A-weighted sound ratings shown have been calculated per AMCA International Standard 301. Values shown are for outlet LwoA sound power levels for installation Type A: free inlet, free outlet.



Performance Curve

AXV-F 2000-785-7, 50 Hz *wolter*

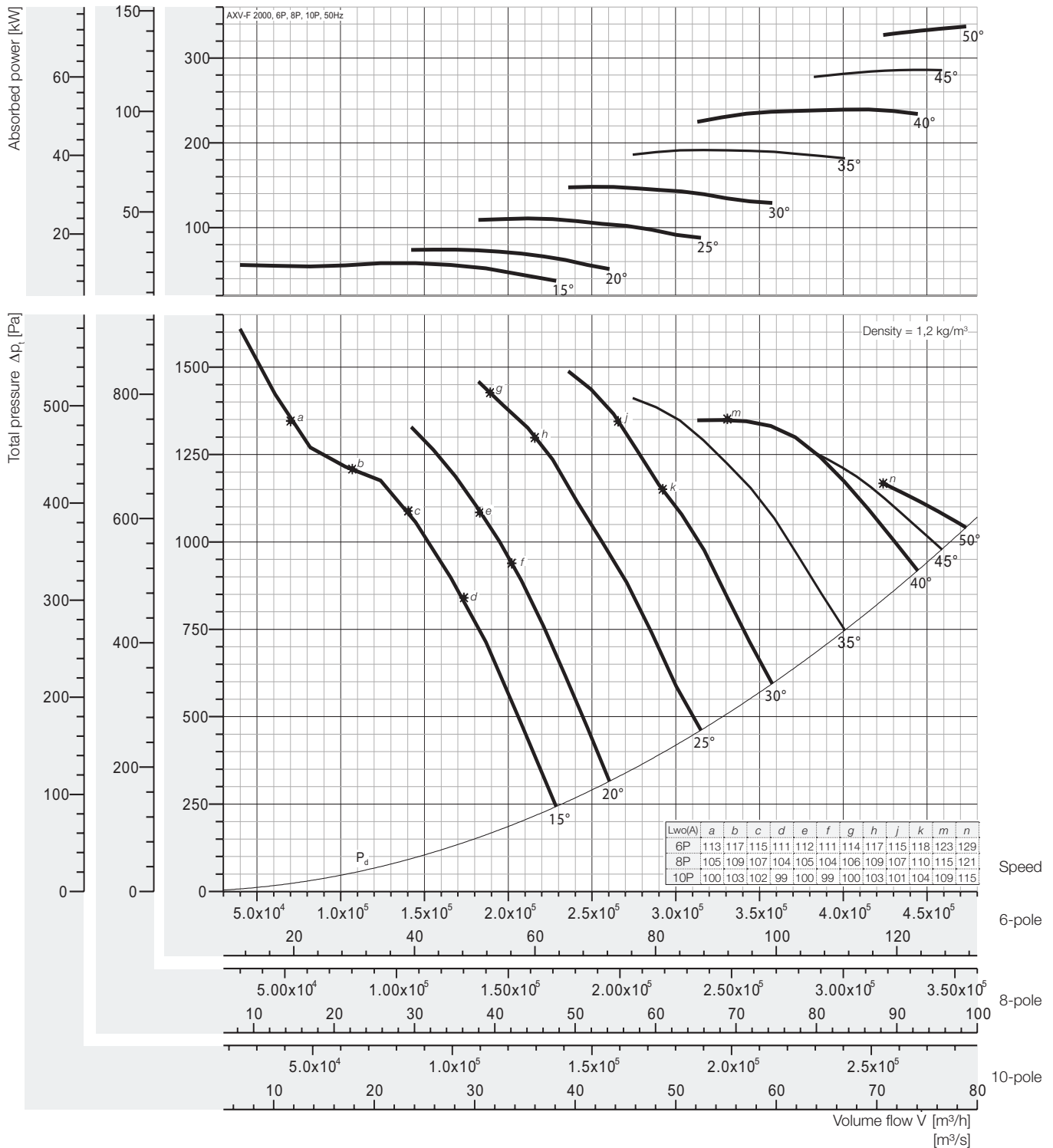

Peak absorbed power [kW]

6-pole = 1000 rpm; 8-pole = 750 rpm; 10-pole = 600 rpm;

N Poles	Pitch angle [°]							
	15	20	25	30	35	40	45	50
6P motor	58,11	74,14	110,9	148,2	191,5	239,4	285,9	337,2
8P motor	24,51	31,28	46,80	62,51	80,79	101,0	120,6	142,2
10P motor	12,55	16,01	23,96	32,01	41,36	51,71	61,76	72,84

Fan test laboratory AMCA 210 Fig.15, Test Chamber. Performance certified is for installation type A - Free inlet, Free outlet with partition. Performance ratings do not include the effects of appurtenances (accessories-belt cover, pulley & belt). Power rating (kW) does not include transmission losses.

The A-weighted sound ratings shown have been calculated per AMCA International Standard 301. Values shown are for outlet LwoA sound power levels for installation Type A: free inlet, free outlet.



Performance Curve

AXV-F 2200-862-7, 50 Hz

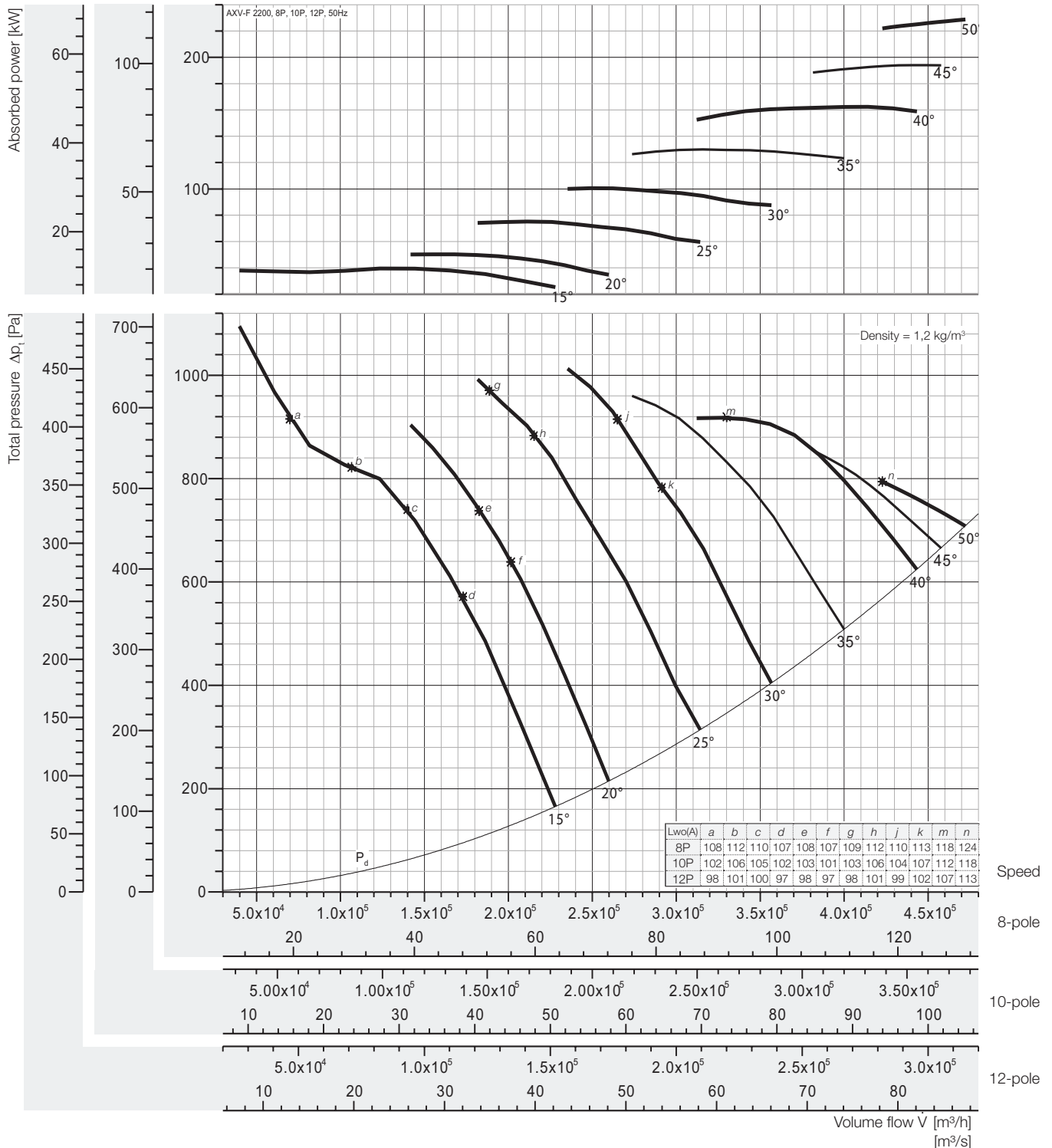

Peak absorbed power [kW]

8-pole = 750 rpm; 10-pole = 600 rpm; 12-pole = 500 rpm;

N Poles	Pitch angle [°]							
	15	20	25	30	35	40	45	50
8P motor	39,44	50,32	75,29	100,6	130,0	162,4	194,1	228,8
10P motor	20,19	25,76	38,55	51,49	66,54	83,18	99,36	117,2
12P motor	11,68	14,91	22,31	29,80	38,51	48,14	57,5	67,81

Fan test laboratory AMCA 210 Fig.15, Test Chamber. Performance certified is for installation type A - Free inlet, Free outlet with partition. Performance ratings do not include the effects of appurtenances (accessories-belt cover, pulley & belt). Power rating (kW) does not include transmission losses.

The A-weighted sound ratings shown have been calculated per AMCA International Standard 301. Values shown are for outlet LwoA sound power levels for installation Type A: free inlet, free outlet.



Performance Curve

AXV-F 2400-942-7, 50 Hz *wolter*

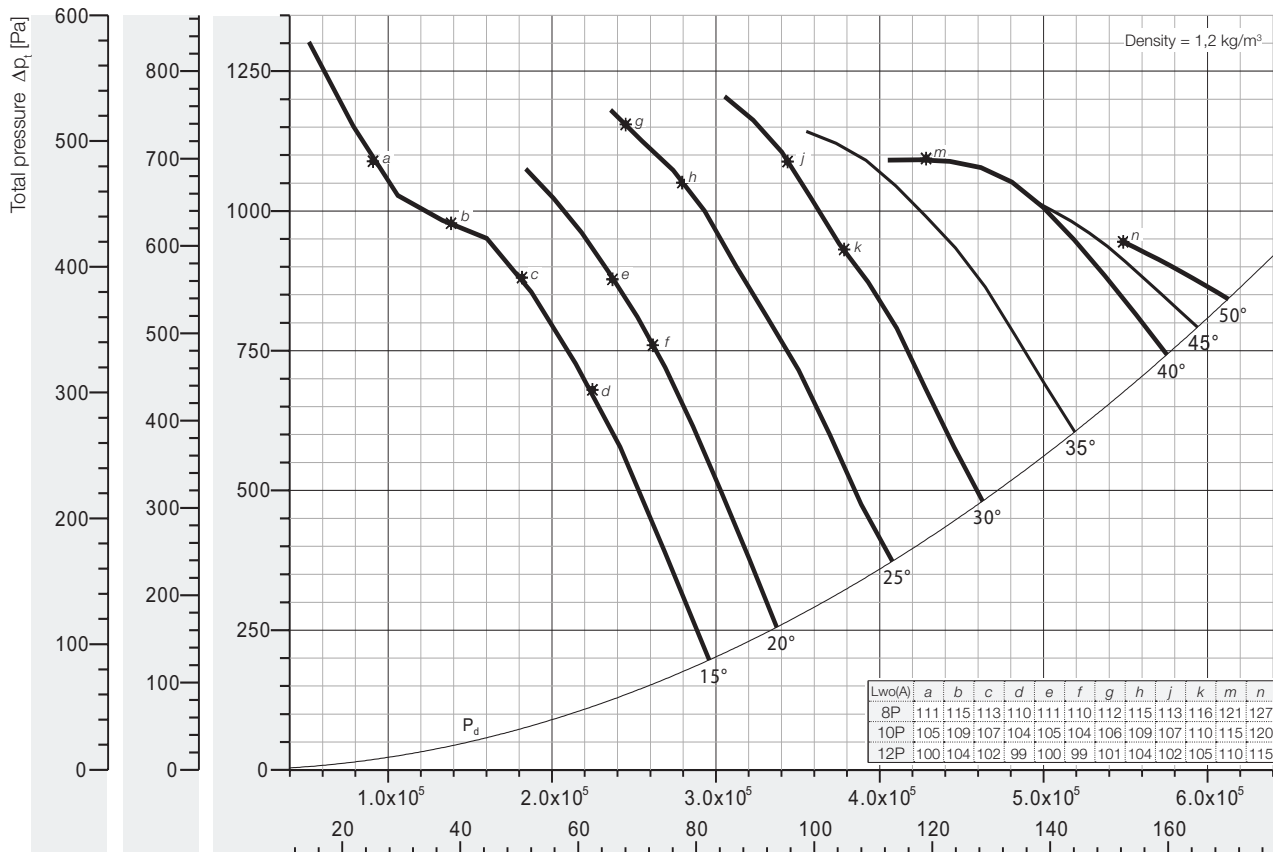
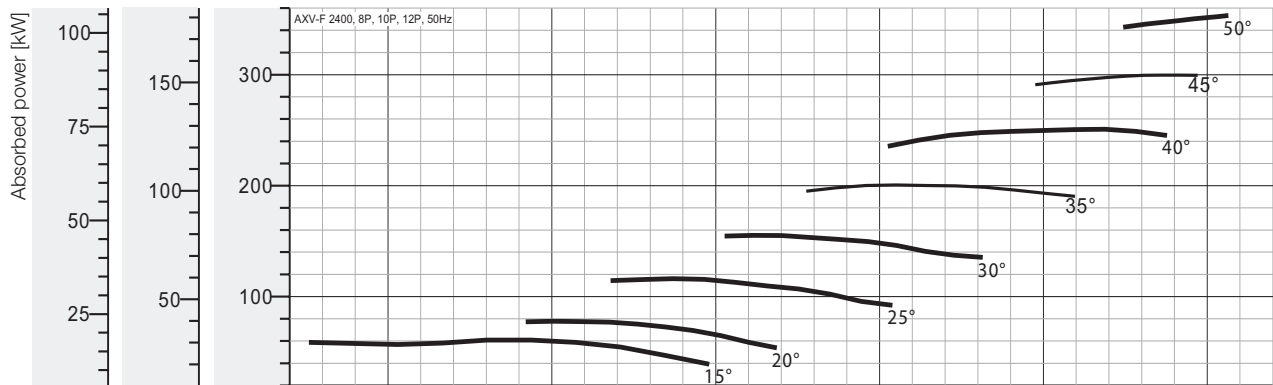

Speed

8-pole

10-pole

12-pole

Volume flow V [m³/h]
[m³/s]

Peak absorbed power [kW]

8-pole = 750 rpm; 10-pole = 600 rpm; 12-pole = 500 rpm;

N Poles	Pitch angle [°]							
	15	20	25	30	35	40	45	50
8P motor	60,87 75	77,67 90	116,2 132	155,2 160	200,6 250	250,8 315	299,5	353,2 355
10P motor	31,17 37	39,77 45	59,50 75	79,48 90	102,7 110	128,4 132	153,4 160	180,9 200
12P motor	18,04 18,5	23,01 30	34,44 37	45,99 55	59,44 75	74,30	88,76 90	104,7 110

Fan test laboratory AMCA 210 Fig.15, Test Chamber. Performance certified is for installation type A - Free inlet, Free outlet with partition. Performance ratings do not include the effects of appurtenances (accessories-belt cover, pulley & belt). Power rating (kW) does not include transmission losses.

The A-weighted sound ratings shown have been calculated per AMCA International Standard 301. Values shown are for outlet LwₒA sound power levels for installation Type A: free inlet, free outlet.



Performance Curve

AXV-F 2500-980-7, 50 Hz

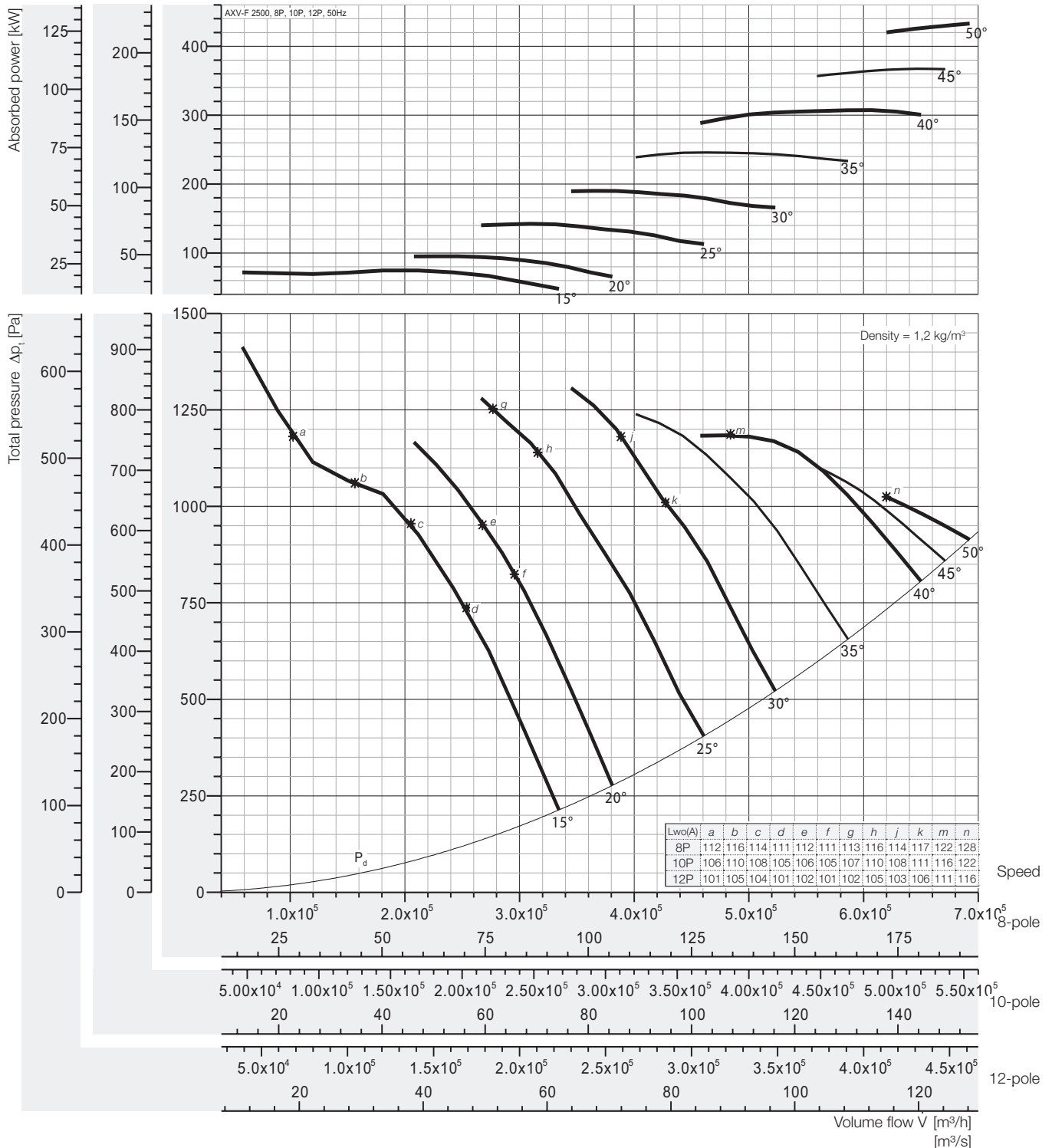

Peak absorbed power [kW]

8-pole = 750 rpm; 10-pole = 600 rpm; 12-pole = 500 rpm;

N Poles	Pitch angle [°]							
	15	20	25	30	35	40	45	50
8P motor	74,63	95,22	142,5	190,3	245,9	307,4	367,2	433,1
	75	110	160	200	250	315	400	450
10P motor	38,22	48,75	72,95	97,43	125,9	157,4	188,0	221,7
	45	55	75	110	132	160	200	250
12P motor	22,11	28,21	42,22	56,39	72,87	91,09	108,8	128,3
	30	45	75	110	132	160	200	250

Fan test laboratory AMCA 210 Fig.15, Test Chamber. Performance certified is for installation type A - Free inlet, Free outlet with partition. Performance ratings do not include the effects of appurtenances (accessories-belt cover, pulley & belt). Power rating (kW) does not include transmission losses.

The A-weighted sound ratings shown have been calculated per AMCA International Standard 301. Values shown are for outlet Lw(A) sound power levels for installation Type A: free inlet, free outlet.



Performance Curve

AXV-F 2600-1020-7, 50 Hz *wolter*

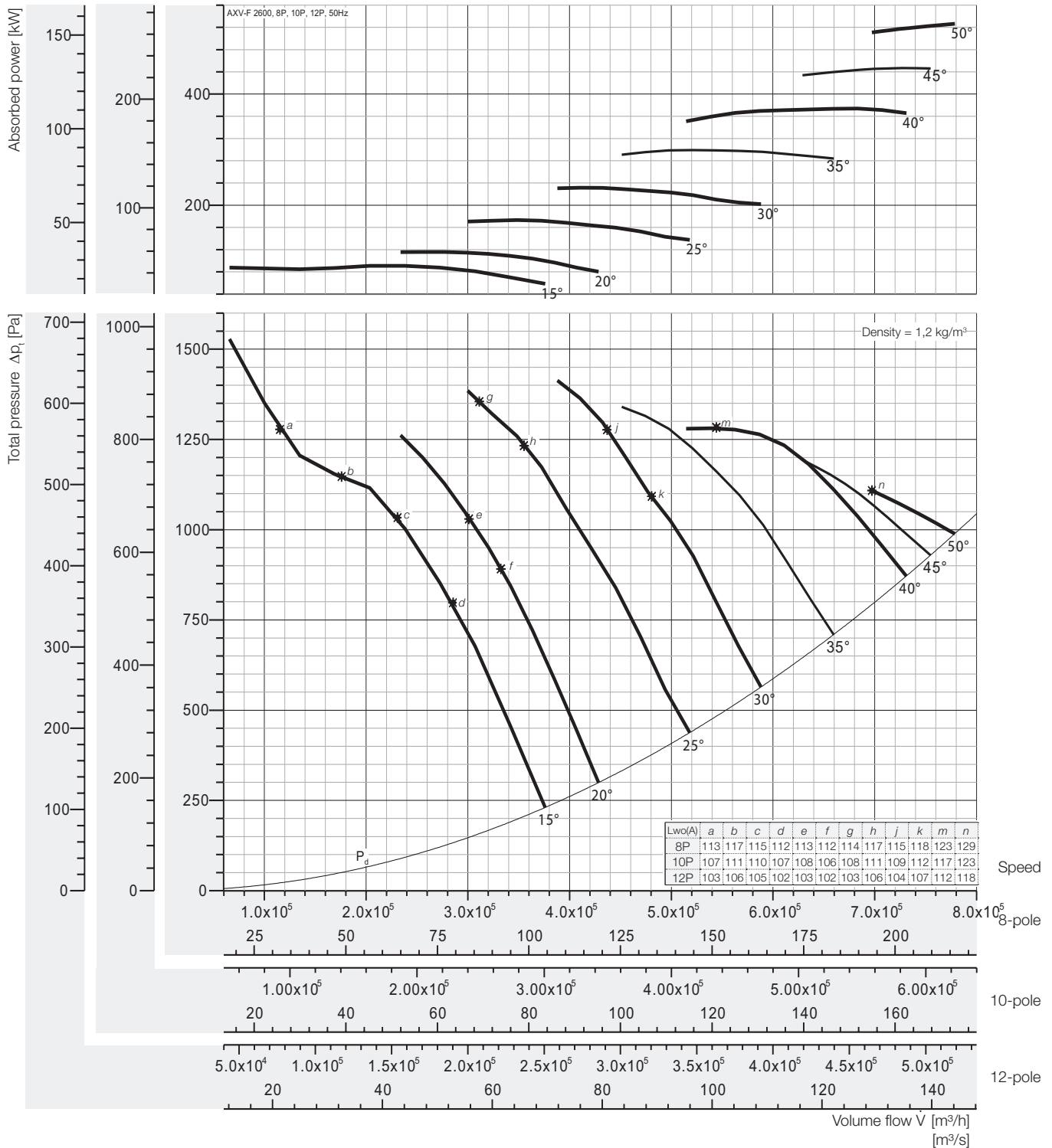

Peak absorbed power [kW]

8-pole = 750 rpm; 10-pole = 600 rpm; 12-pole = 500 rpm;

N Poles	Pitch angle [°]							
	15	20	25	30	35	40	45	50
8P motor	90,76	115,8	173,3	231,4	299,1	373,9	446,6	526,7
10P motor	46,47	59,29	88,72	118,50	153,13	191,4	228,7	269,6
12P motor	26,89	34,31	51,34	68,58	88,62	110,8	132,3	156,0

Fan test laboratory AMCA 210 Fig.15, Test Chamber. Performance certified is for installation type A - Free inlet, Free outlet with partition. Performance ratings do not include the effects of appurtenances (accessories-belt cover, pulley & belt). Power rating (kW) does not include transmission losses.

The A-weighted sound ratings shown have been calculated per AMCA International Standard 301. Values shown are for outlet LwoA sound power levels for installation Type A: free inlet, free outlet.



Performance Curve

AXV-F 2800-1095-7, 50 Hz *wolter*

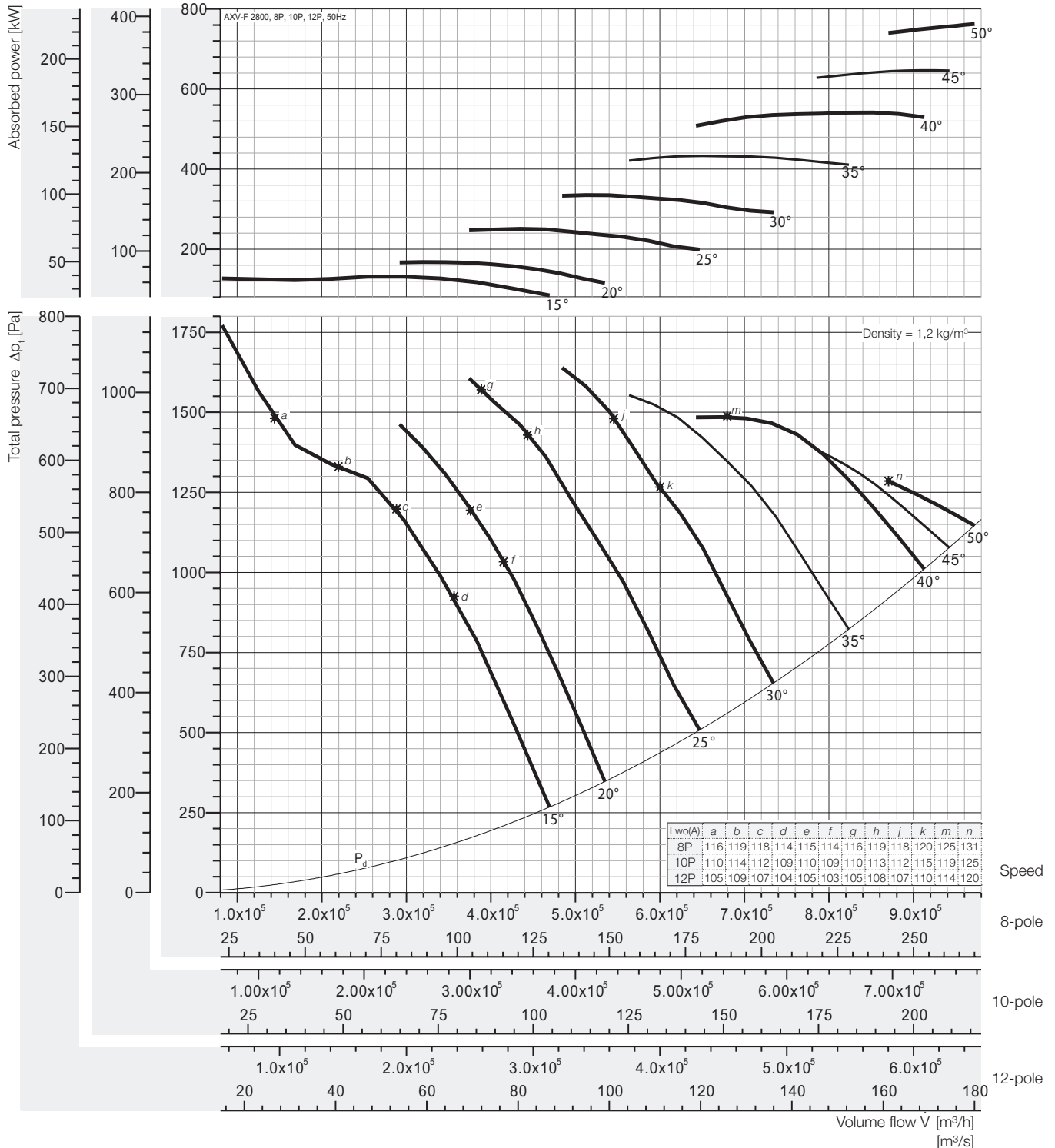

Peak absorbed power [kW]

8-pole = 750 rpm; 10-pole = 600 rpm; 12-pole = 500 rpm;

N Poles	Pitch angle [°]							
	15	20	25	30	35	40	45	50
8P motor	131,4	167,6	250,8	335,0	432,9	541,2	646,5	762,4
	132	200	315	355	450	560	710	-
10P motor	67,26	85,82	128,4	171,5	221,7	277,1	331,0	390,3
	75	90	132	200	250	315	355	400
12P motor	38,93	49,67	74,32	99,26	128,3	160,3	191,5	225,9
	45	55	75	110	132	200	-	250

Fan test laboratory AMCA 210 Fig.15, Test Chamber. Performance certified is for installation type A - Free inlet, Free outlet with partition. Performance ratings do not include the effects of appurtenances (accessories-belt cover, pulley & belt). Power rating (kW) does not include transmission losses.

The A-weighted sound ratings shown have been calculated per AMCA International Standard 301. Values shown are for outlet LwoA sound power levels for installation Type A: free inlet, free outlet.

Introducing the Fan Energy Index

The FEI is a ratio of the actual fan efficiency to a baseline fan efficiency, both calculated at a given airflow and pressure point (FEI_s is calculated using a static pressure basis, FEI_t is calculated using a total pressure basis). Since these efficiencies are each calculated at the same airflow and pressure, FEI is also defined as the ratio of the baseline electrical power to the actual electrical power of a fan.

The FEI was designed to encourage responsible application of fans and drive significant and quantifiable energy savings through energy codes, utility rebate programs and federal regulations. This is accomplished by establishing the minimum fan efficiency or maximum fan electrical input power at design airflow and pressure. The FEI can be used by:

- Regulators to improve the efficiency of fan designs and limit market availability of less efficient fans
- Utilities to establish rebate programs to incentivize the efficient use of fans
- Code bodies to drive building owners and contractors to using more energy efficient fans for ventilation and process applications
- Purchasing agents to evaluate the fan selections and their suitability for specific applications

Selection Example

The **direct driven** axial fan AXV-F 500/18° with three-phase 50Hz motor power supply, by plotting the FEI curve as per the right graph, the FEI_t value will be 1.70 under the duty 4,000CMH airflow, 202Pa total pressure running at 1,500rpm.

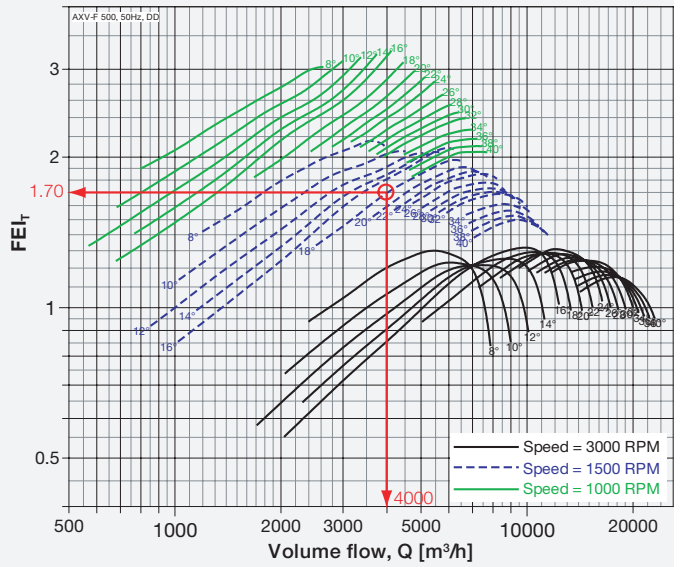

Direct Driven Models, Size from 500 to 2800, 50Hz

Model: AXV-F 500-150-6

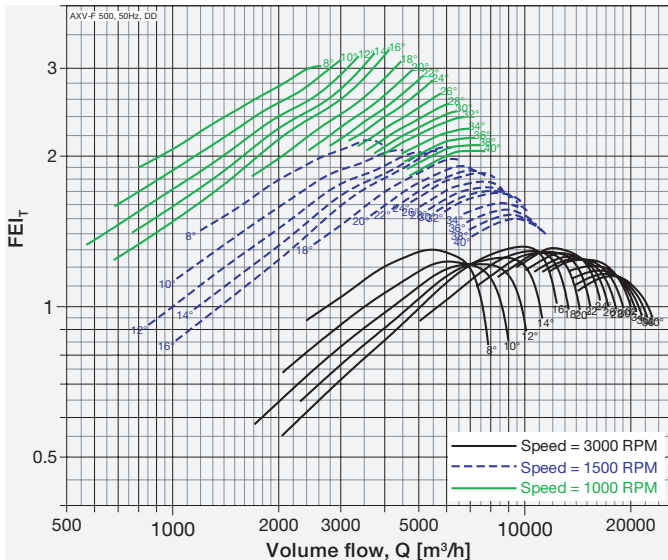

Model: AXV-F 560-168-6

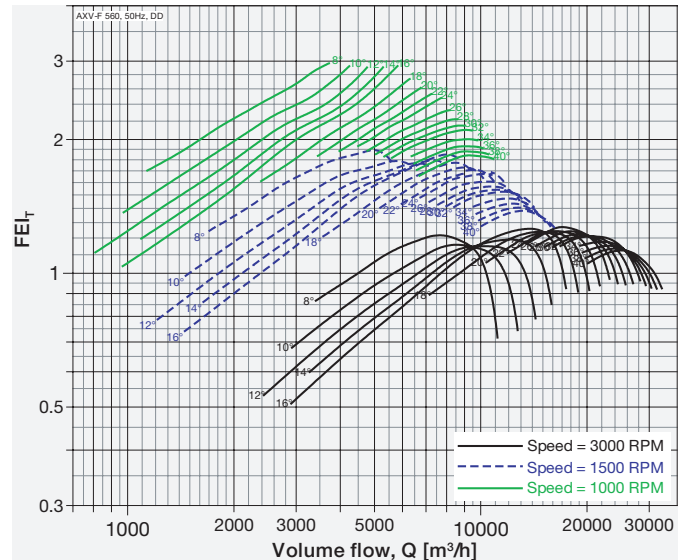

Model: AXV-F 630-200-6

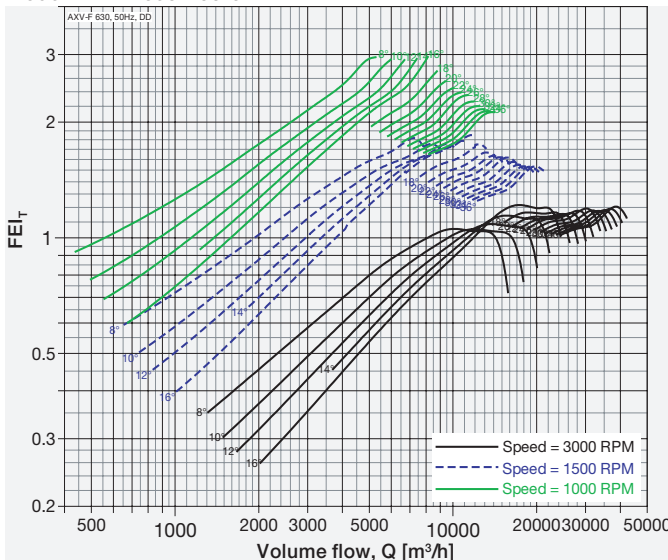

Model: AXV-F 710-212-6

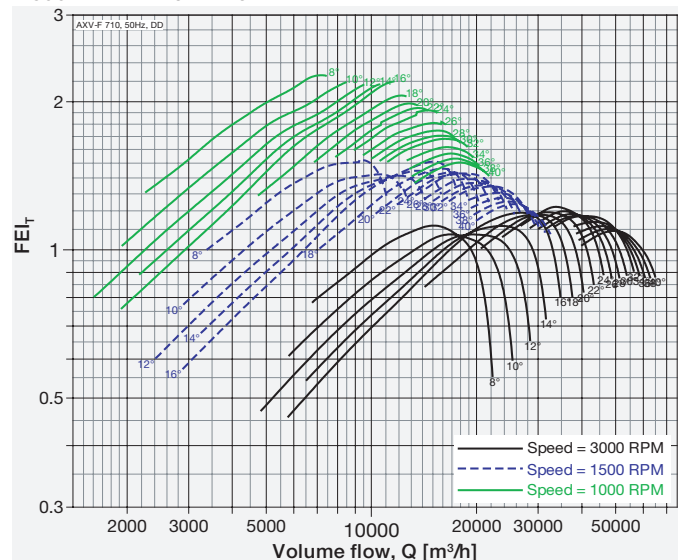

Performance of size 500 to 1250 certified is for installation type D - Ducted inlet, Ducted outlet, Performance of size 1400 to 2800 certified is for installation type A - Free inlet, Free outlet with partition. Power rating (kW) does not include transmission losses. Performance ratings do not include the effects of appurtenances (accessories-belt cover, pulley & belt). FEI_t / FEI_s values are calculated in accordance with ANSI/AMCA Standard 208 and are based on default motor efficiencies (Direct Driven type). FEI_t / FEI_s values for fans with specific motors will vary slightly from those shown.



Model: AXV-F 800-238-6

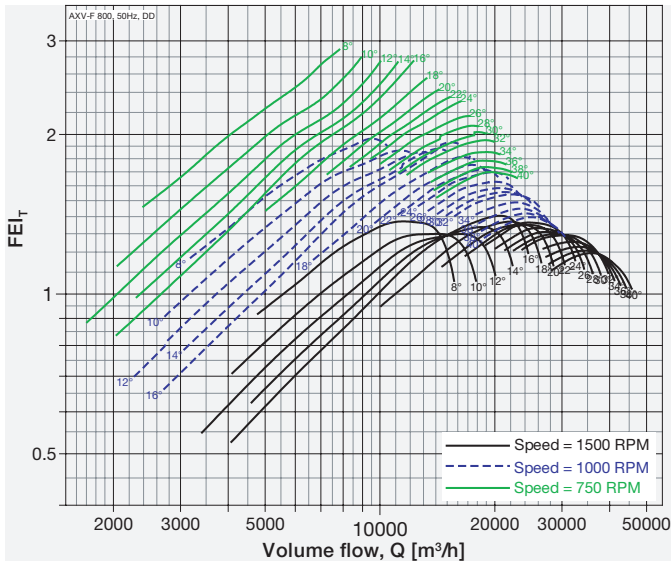

Model: AXV-F 900-267-6

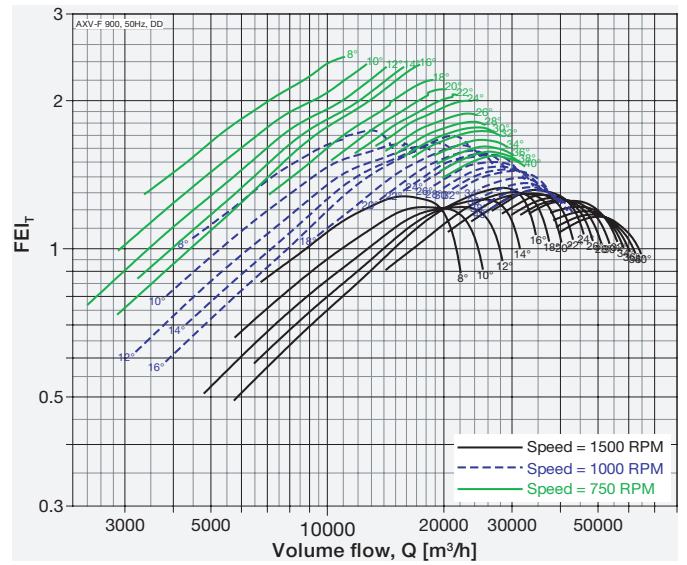

Model: AXV-F 1000-420-6

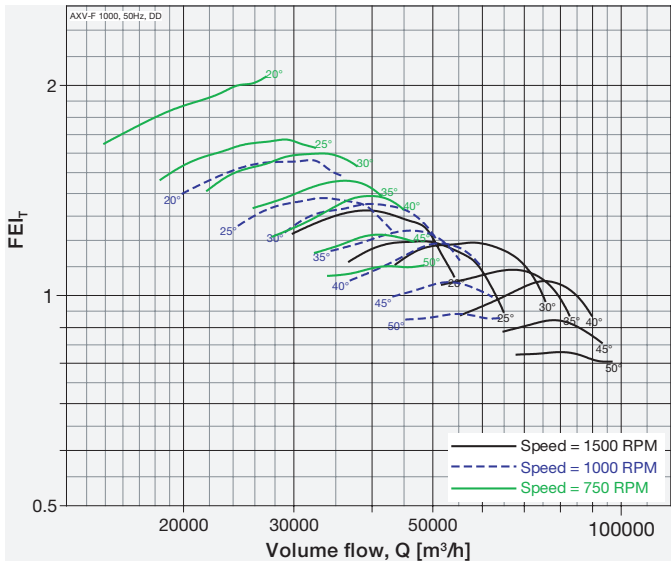

Model: AXV-F 1120-472-6

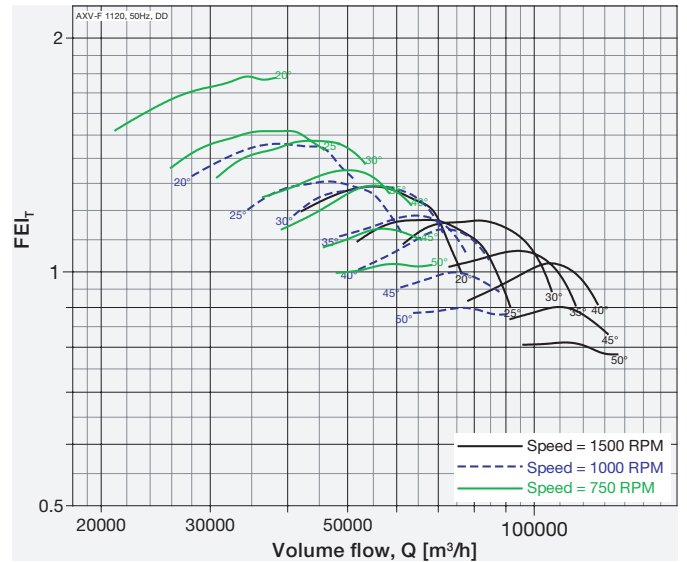

Model: AXV-F 1250-525-6

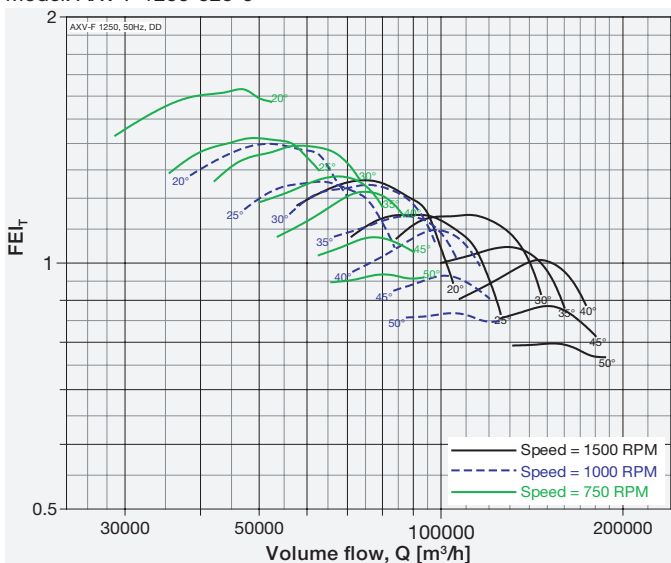

Model: AXV-F 1400-550-7

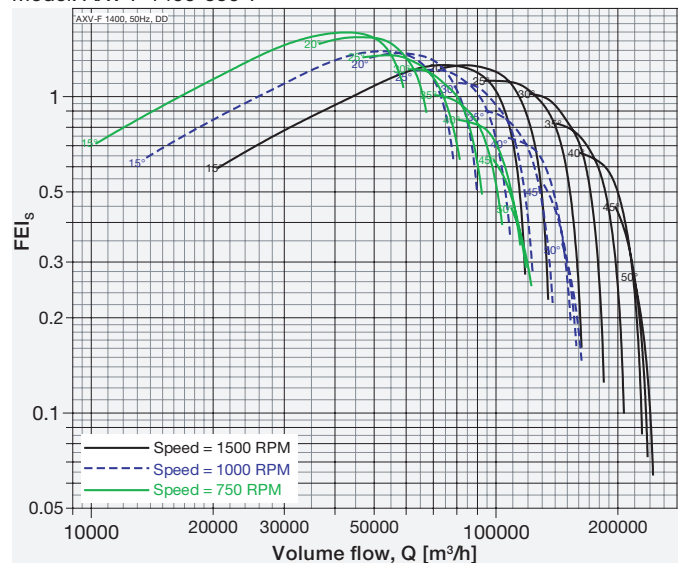

Performance of size 500 to 1250 certified is for installation type D - Ducted inlet, Ducted outlet, Performance of size 1400 to 2800 certified is for installation type A - Free inlet, Free outlet with partition. Power rating (kW) does not include transmission losses. Performance ratings do not include the effects of appurtenances (accessories-belt cover, pulley & belt). FEI_T / FEI_S values are calculated in accordance with ANSI/AMCA Standard 208 and are based on default motor efficiencies (Direct Driven type). FEI_T / FEI_S values for fans with specific motors will vary slightly from those shown.



Model: AXV-F 1600-625-7

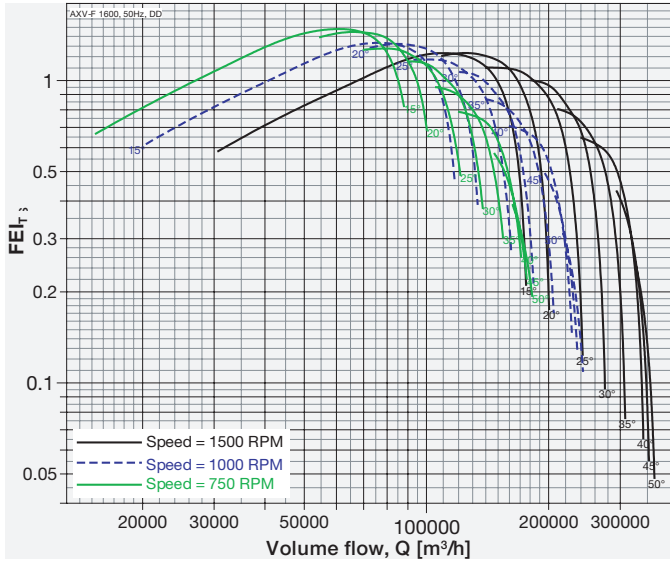

Model: AXV-F 1800-710-7

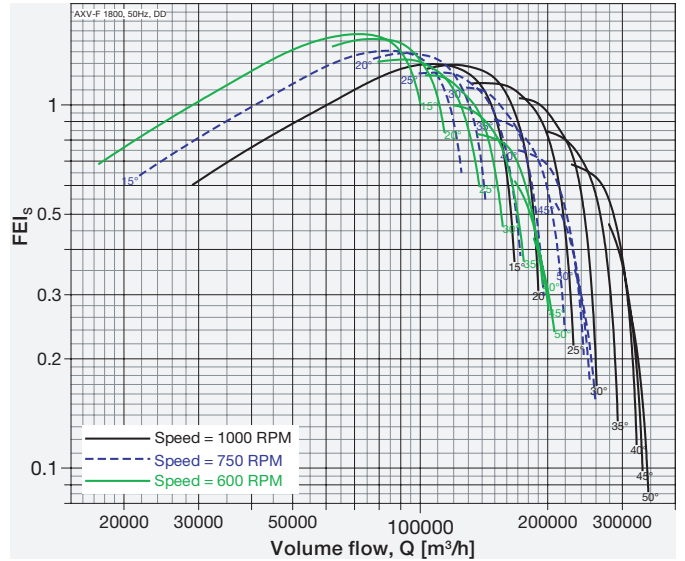

Model: AXV-F 2000-785-7

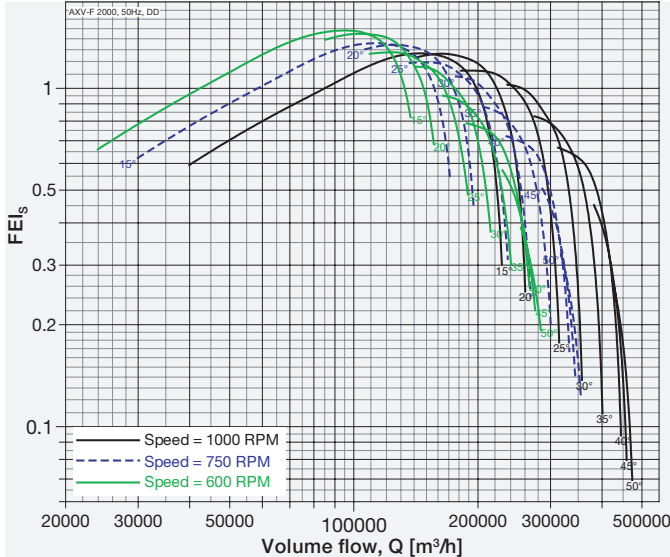

Model: AXV-F 2200-862-7

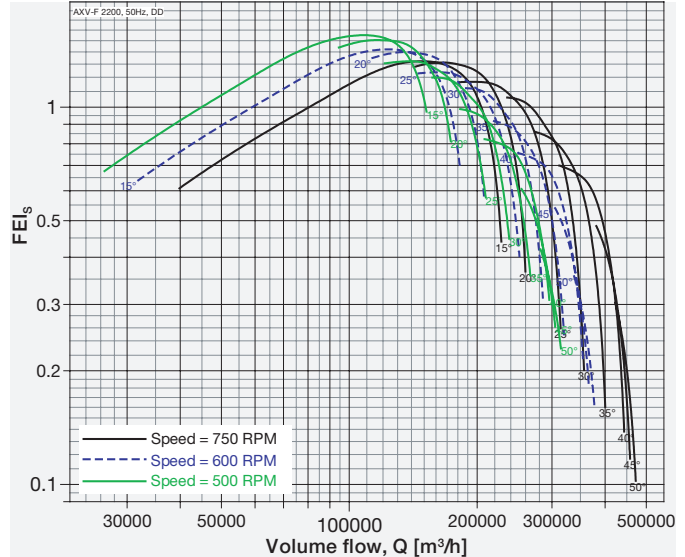

Model: AXV-F 2400-942-7

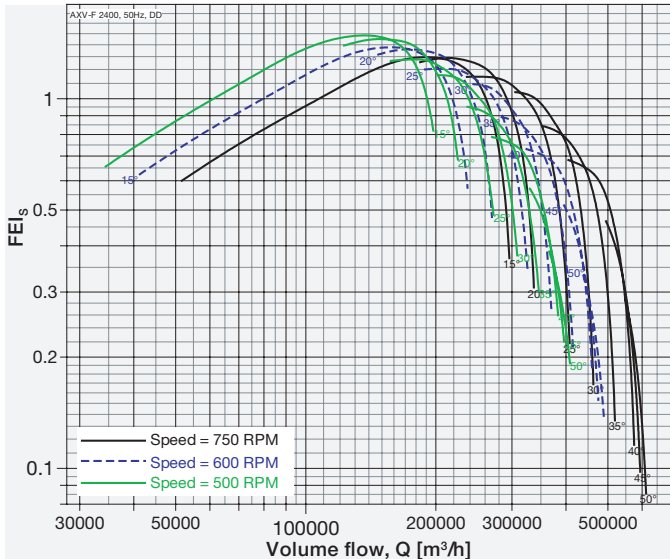

Model: AXV-F 2500-980-7

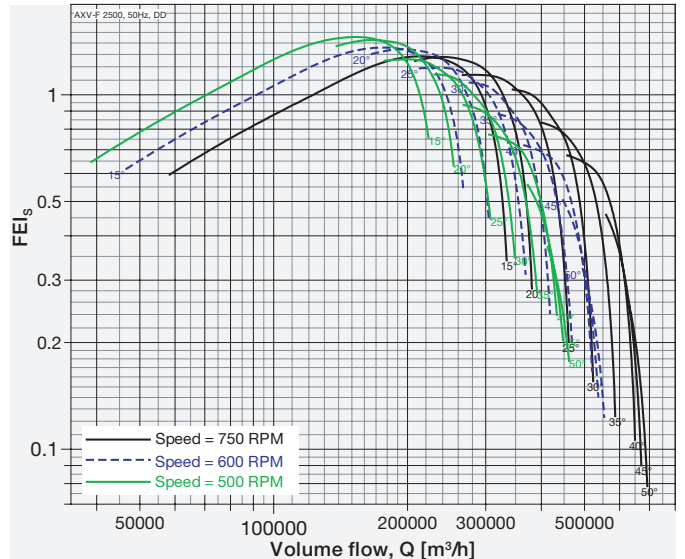

Performance of size 500 to 1250 certified is for installation type D - Ducted inlet, Ducted outlet, Performance of size 1400 to 2800 certified is for installation type A - Free inlet, Free outlet with partition. Power rating (kW) does not include transmission losses. Performance ratings do not include the effects of appurtenances (accessories-belt cover, pulley & belt). FEI_r / FEI_s values are calculated in accordance with ANSI/AMCA Standard 208 and are based on default motor efficiencies (Direct Driven type). FEI_r / FEI_s values for fans with specific motors will vary slightly from those shown.



Fan Energy Index

Direct Driven, 50Hz



Model: AXV-F 2600-1020-7

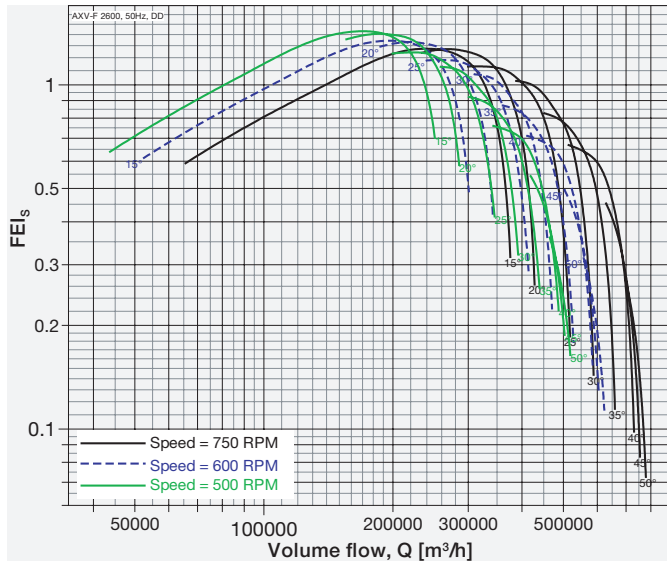

Model: AXV-F 2800-1095-7

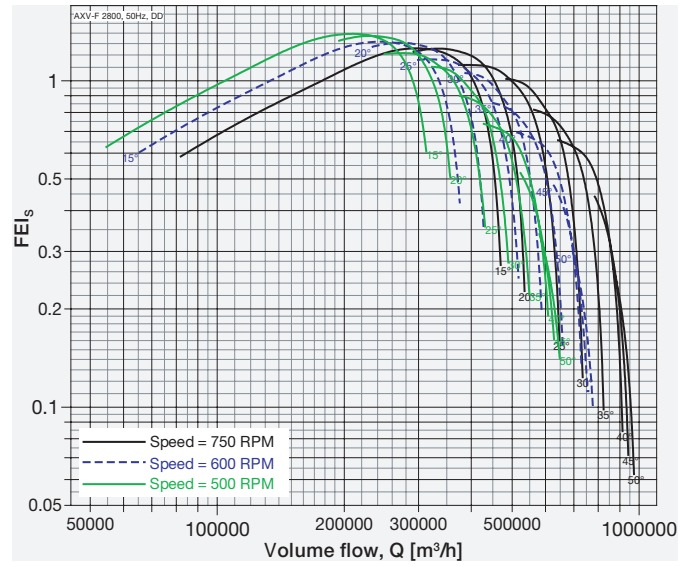

Performance of size 500 to 1250 certified is for installation type D - Ducted inlet, Ducted outlet, Performance of size 1400 to 2800 certified is for installation type A - Free inlet, Free outlet with partition. Power rating (kW) does not include transmission losses. Performance ratings do not include the effects of appurtenances (accessories-belt cover, pulley & belt). FEI_1 / FEI_s values are calculated in accordance with ANSI/AMCA Standard 208 and are based on default motor efficiencies (Direct Driven type). FEI_1 / FEI_s values for fans with specific motors will vary slightly from those shown.



Belt Driven Models, Size from 500 to 2800, 50Hz

Model: AXV-F 500-150-6

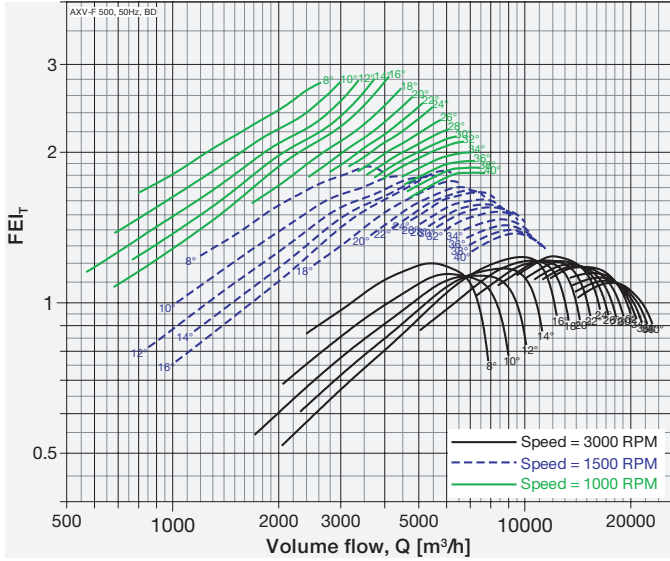

Model: AXV-F 560-168-6

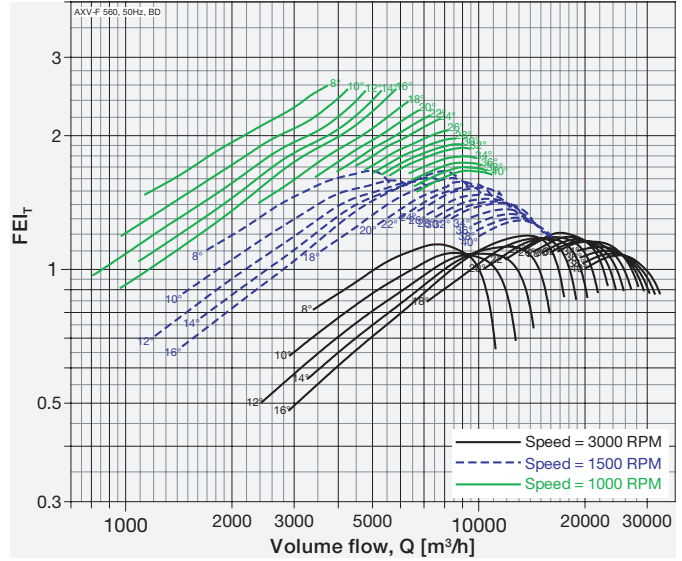

Model: AXV-F 630-200-6

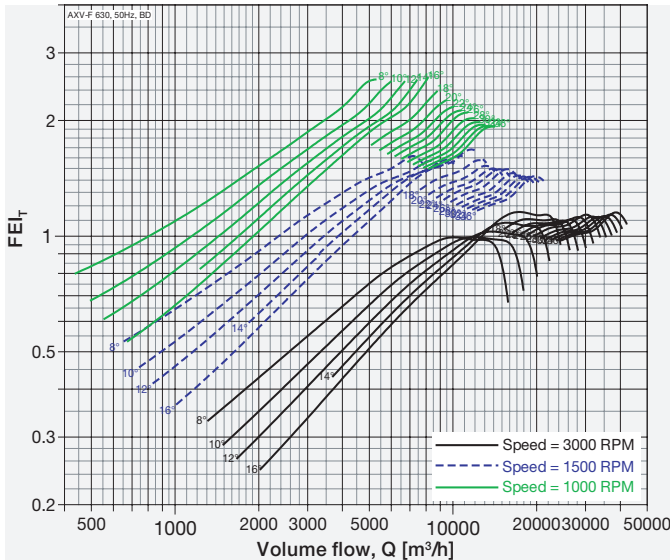

Model: AXV-F 710-212-6

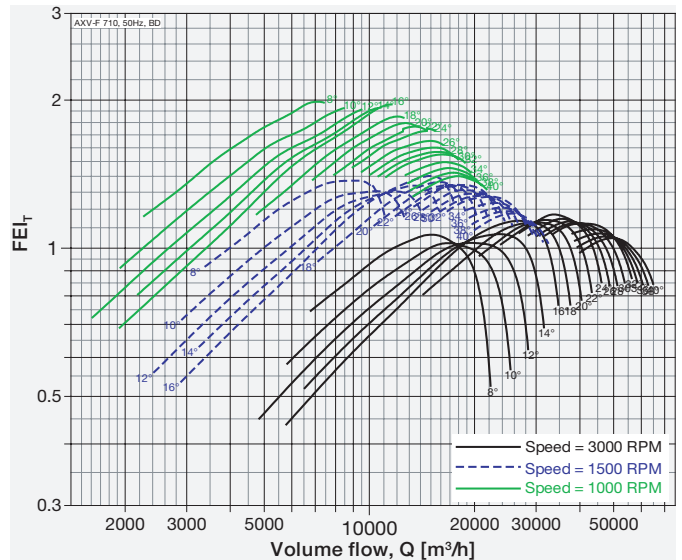

Model: AXV-F 800-238-6

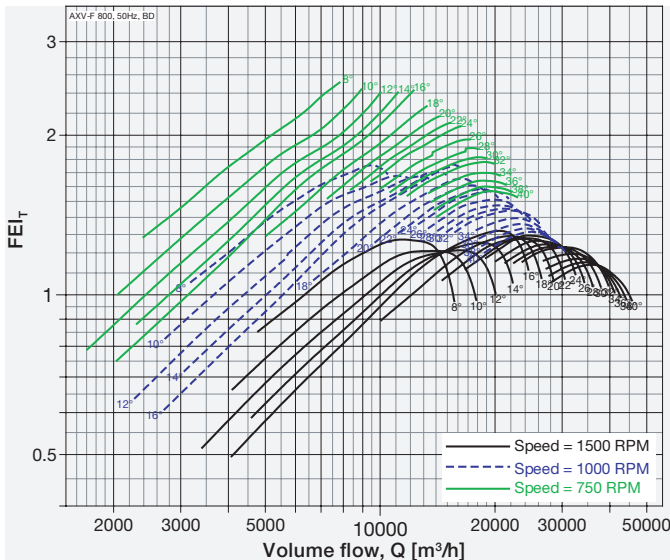

Model: AXV-F 900-267-6

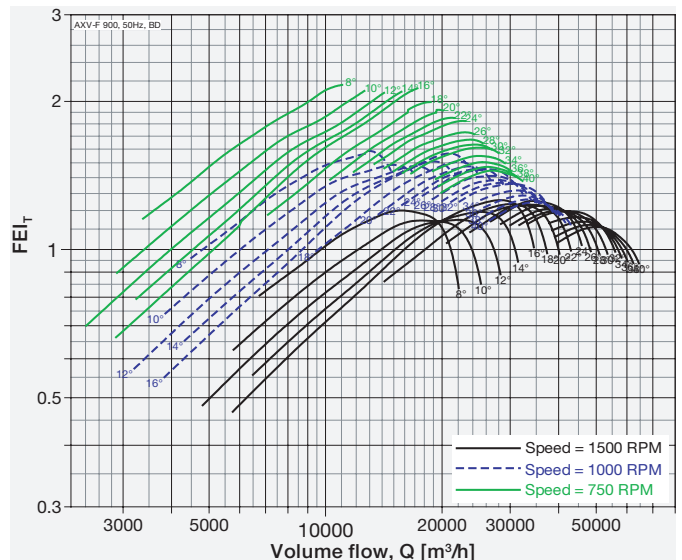

Performance of size 500 to 1250 certified is for installation type D - Ducted inlet, Ducted outlet, Performance of size 1400 to 2800 certified is for installation type A - Free inlet, Free outlet with partition. Power rating (kW) does not include transmission losses. Performance ratings do not include the effects of appurtenances (accessories-belt cover, pulley & belt). FEI_T / FEI_S values are calculated in accordance with ANSI/AMCA Standard 208 and are based on default motor efficiencies (Belt Driven type). FEI_T / FEI_S values for fans with specific motors will vary slightly from those shown.



Model: AXV-F 1000-420-6

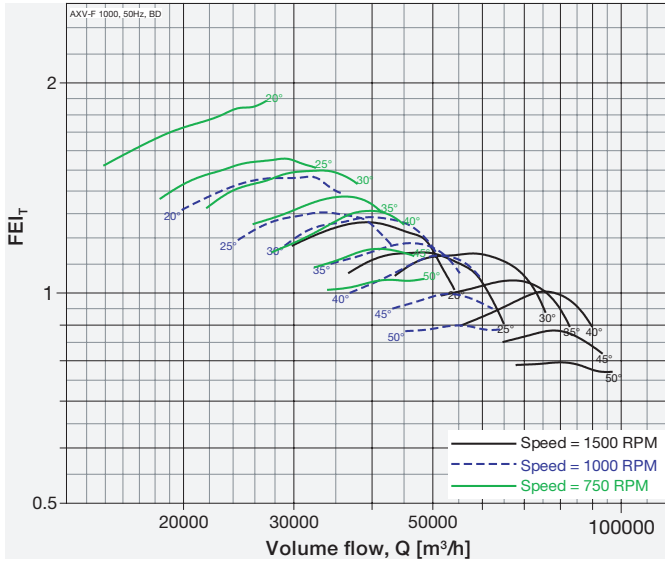

Model: AXV-F 1120-472-6

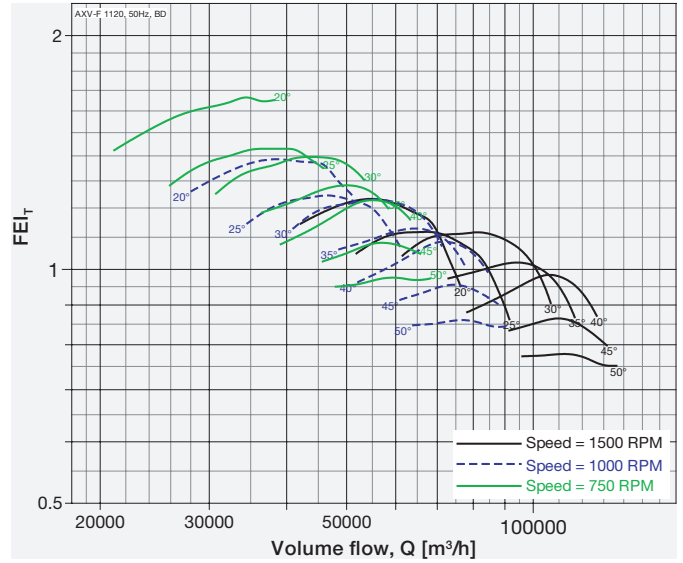

Model: AXV-F 1250-525-6

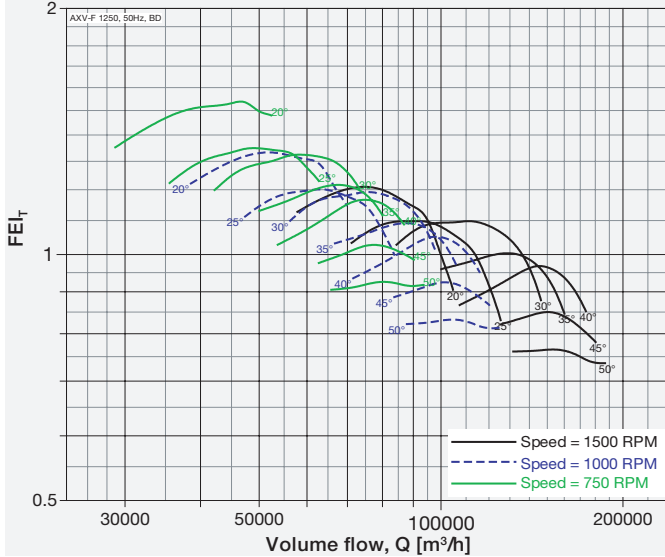

Model: AXV-F 1400-550-7

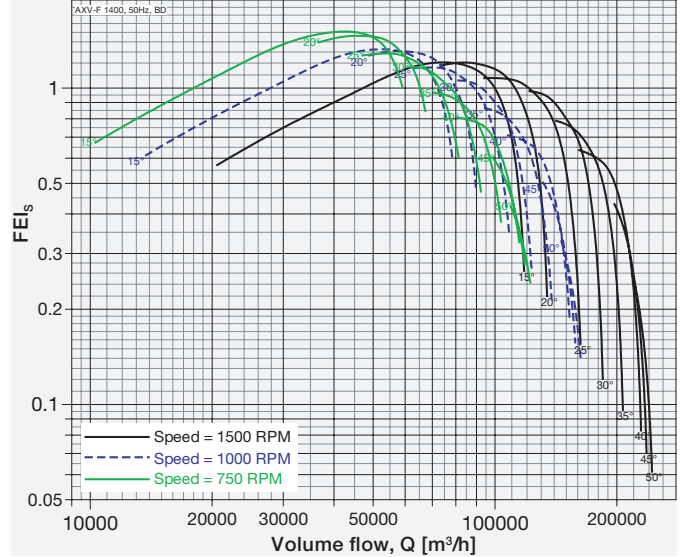

Model: AXV-F 1600-625-7

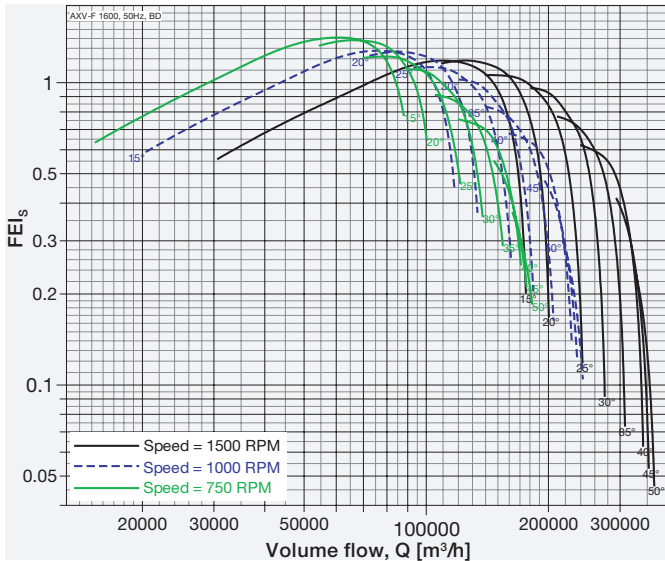

Model: AXV-F 1800-710-7

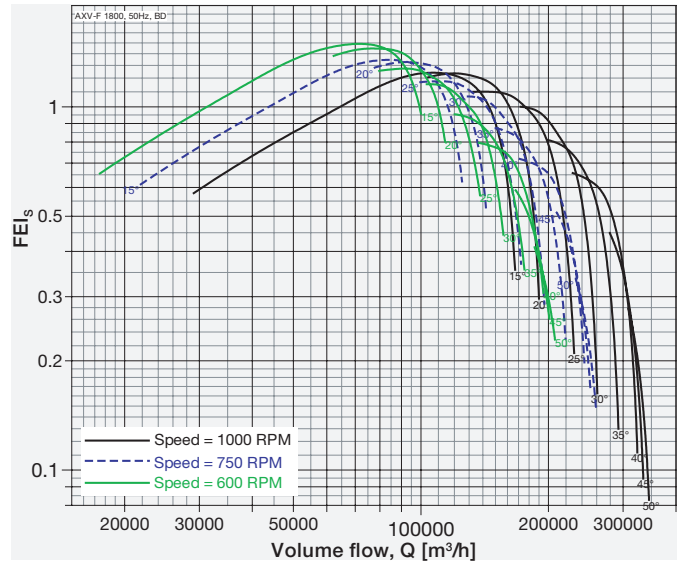

Performance of size 500 to 1250 certified is for installation type D - Ducted inlet, Ducted outlet, Performance of size 1400 to 2800 certified is for installation type A - Free inlet, Free outlet with partition. Power rating (kW) does not include transmission losses. Performance ratings do not include the effects of aperturancs (accessories-belt cover, pulley & belt). FEI_T / FEI_S values are calculated in accordance with ANSI/AMCA Standard 208 and are based on default motor efficiencies (Belt Driven type). FEI_T / FEI_S values for fans with specific motors will vary slightly from those shown.



Model: AXV-F 2000-780-7

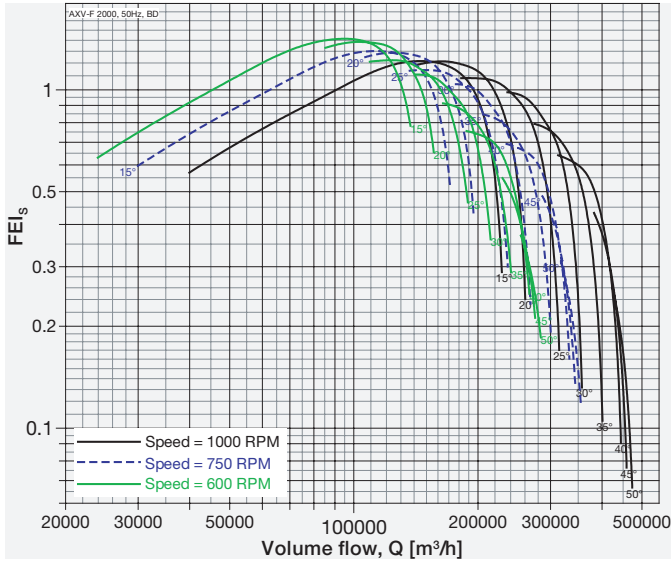

Model: AXV-F 2200-862-7

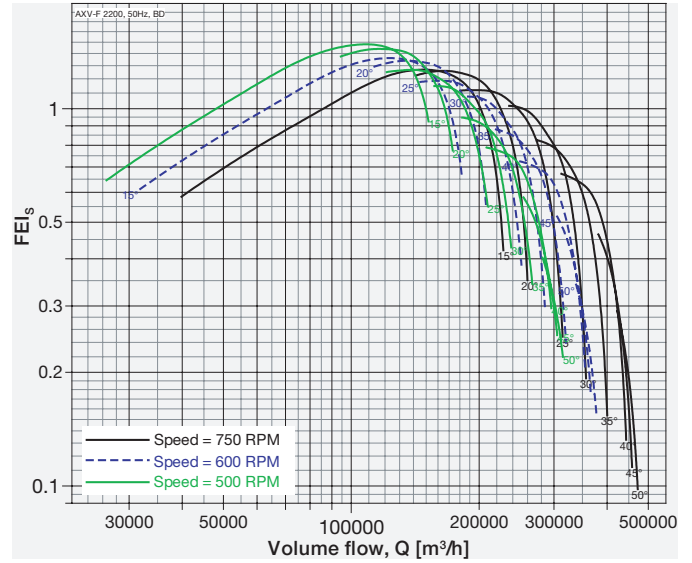

Model: AXV-F 2400-942-7

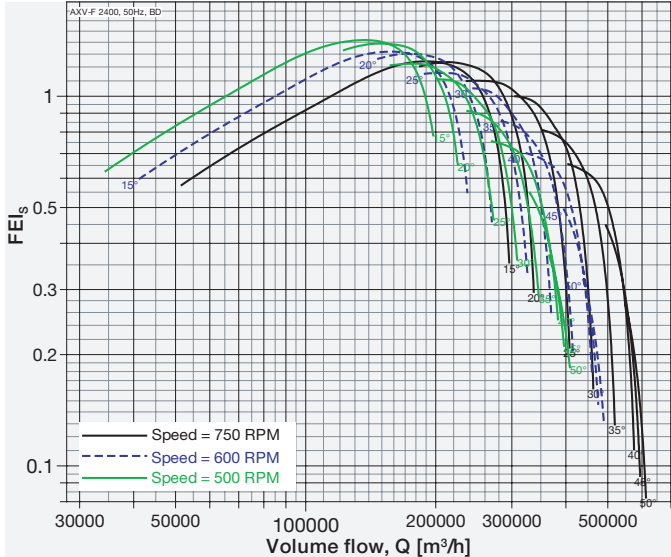

Model: AXV-F 2500-980-7

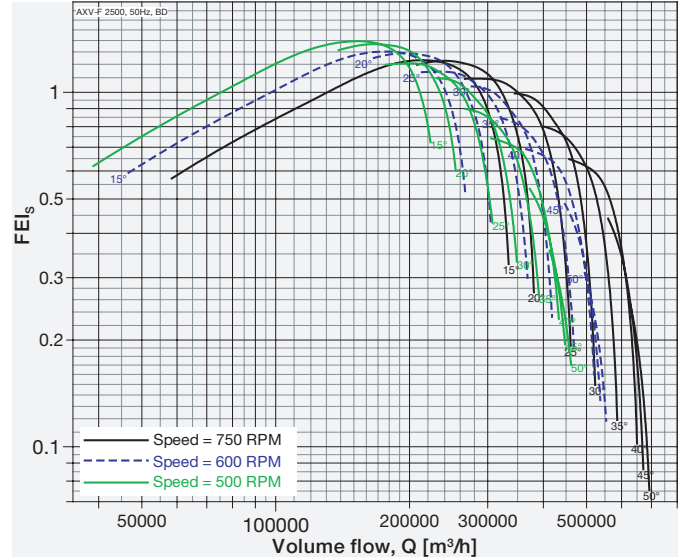

Model: AXV-F 2600-1020-7

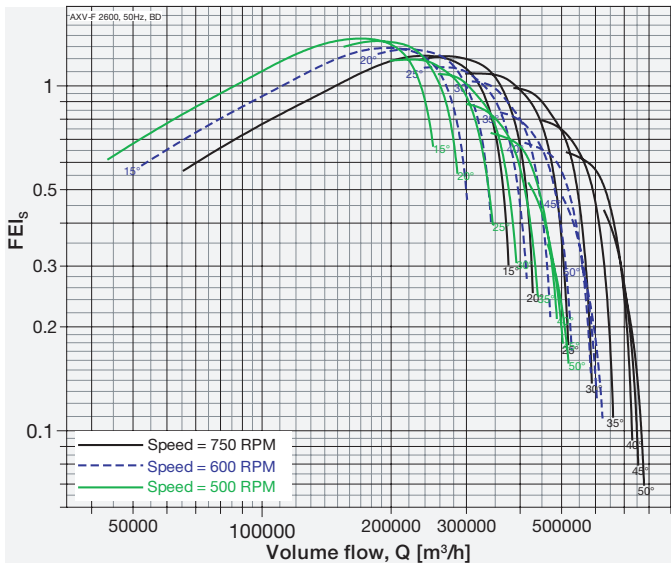

Model: AXV-F 2800-1095-7

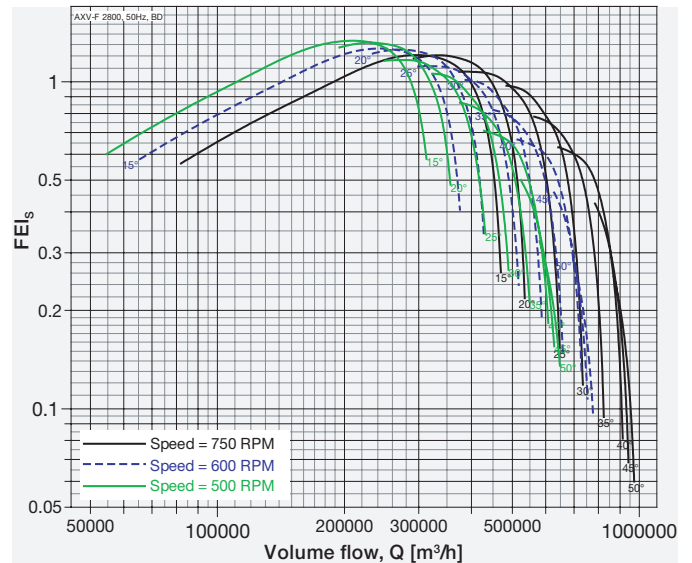

Performance of size 500 to 1250 certified is for installation type D - Ducted inlet, Ducted outlet, Performance of size 1400 to 2800 certified is for installation type A - Free inlet, Free outlet with partition. Power rating (kW) does not include transmission losses. Performance ratings do not include the effects of appurtenances (accessories-belt cover, pulley & belt). FEI_r / FEI_s values are calculated in accordance with ANSI/AMCA Standard 208 and are based on default motor efficiencies (Belt Driven type). FEI_r / FEI_s values for fans with specific motors will vary slightly from those shown.

AMCA - FEG rating

Fan Efficiency Grade: AXV-F, 60Hz



Certified FEGs are determined in accordance with AMCA 205 Energy Efficiency Classification for fans. In conjunction with AMCA 211 Certified Ratings Program, Product Rating Manual for Fan Air Performance. This classification is based on total peak, or optimum, fan efficiency for a given fan speed, impeller diameter and test application category (test configuration). For the purpose of energy classification, the peak efficiency shall be determined at a speed that is lower than the fan's maximum design speed.

The AMCA Certified Ratings Seal applies to the Fan Efficiency Grade (FEG) for AXV-F series Axial Fan model AXV-F 500 to AXV-F 2800 as shown in the table below.

Fan Model No.	Fan Speed (rpm)	Fan Outlet Area (m ²)	Fan Efficiency Grades	Fan Model No.	Fan Speed (rpm)	Fan Outlet Area (m ²)	Fan Efficiency Grade
AXV-F 500-150-6	3600/1800/1200	0,1987	FEG 80	AXV-F 1400-550-7	1800/1200/900	1,5504	FEG 80
AXV-F 560-168-6	3600/1800/1200	0,2507	FEG 75	AXV-F 1600-625-7	1800/1200/900	2,0232	FEG 80
AXV-F 630-200-6	3600/1800/1200	0,3157	FEG 75	AXV-F 1800-710-7	1200/900/720	2,5588	FEG 80
AXV-F 710-212-6	3600/1800/1200	0,3970	FEG 75	AXV-F 2000-785-7	1200/900/720	3,1573	FEG 80
AXV-F 800-238-6	1800/1200/900	0,4989	FEG 75	AXV-F 2200-862-7	900/720/600	3,8186	FEG 80
AXV-F 900-267-6	1800/1200/900	0,6277	FEG 75	AXV-F 2400-942-7	900/720/600	4,5428	FEG 80
AXV-F 1000-420-6	1800/1200/900	0,7901	FEG 75	AXV-F 2500-980-7	900/720/600	4,9284	FEG 80
AXV-F 1120-472-6	1800/1200/900	0,9940	FEG 75	AXV-F 2600-1020-7	900/720/600	5,3297	FEG 80
AXV-F 1250-525-6	1800/1200/900	1,2272	FEG 75	AXV-F 2800-1095-7	900/720/600	6,1795	FEG 80

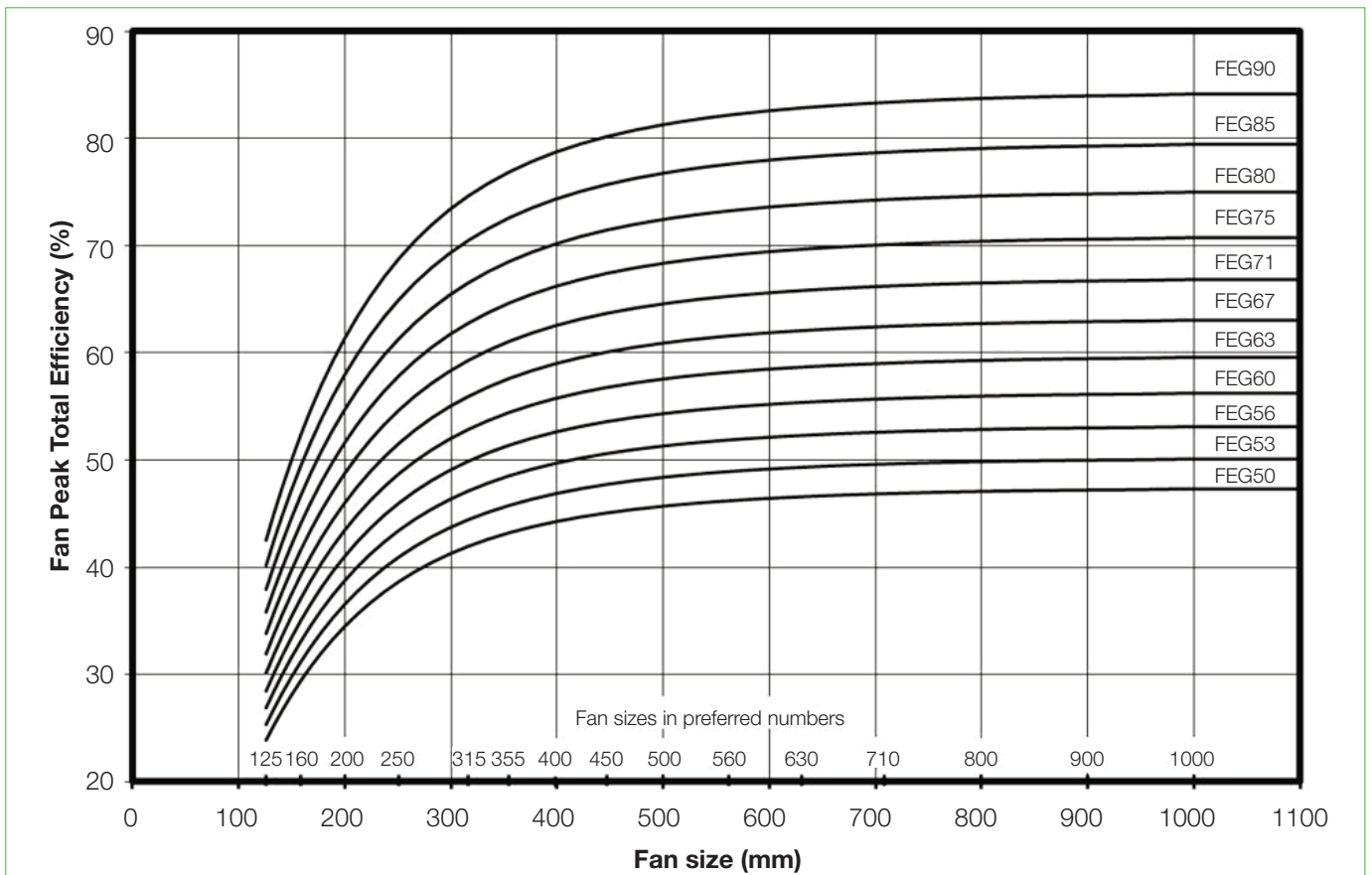



Performance Curve

AXV-F 500-150-6, 60Hz

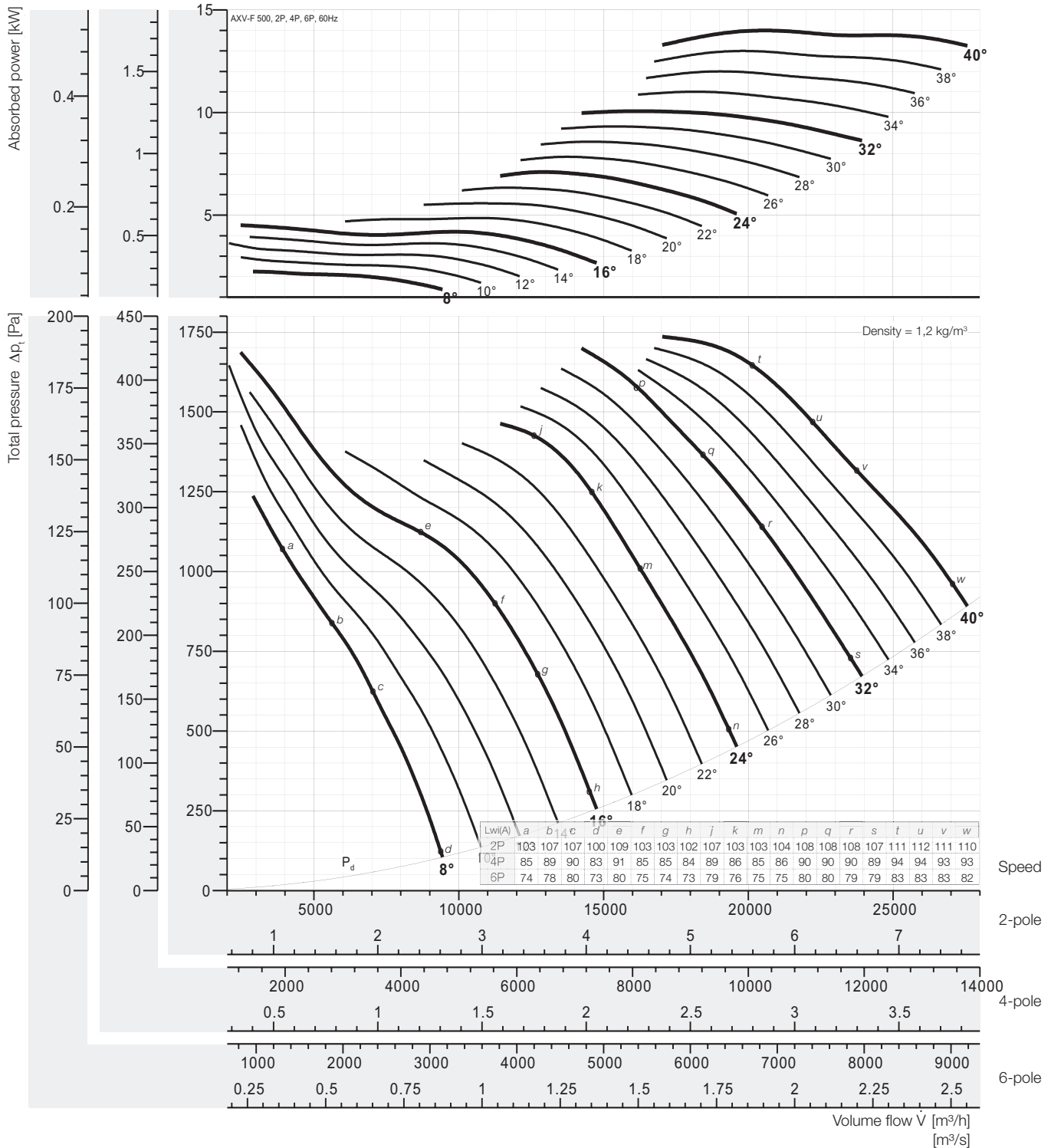

Peak absorbed power [kW]

2-pole = 3600 rpm; 4-pole = 1800 rpm; 6-pole = 1200 rpm;

N Poles	Pitch angle [°]																
	8	10	12	14	16	18	20	22	24	26	28	30	32	34	36	38	40
2P motor	2,251	2,943	3,634	3,936	4,511	4,859	5,572	6,333	7,099	7,839	8,580	9,322	10,06	11,01	12,00	13,00	14,00
	3,0		4,0		-*												
4P motor	0,281	0,368	0,454	0,492	0,564	0,607	0,696	0,792	0,887	0,980	1,072	1,165	1,258	1,376	1,500	1,625	1,749
	0,37		0,55		0,75		1,1				1,5				2,2		
6P motor	0,083	0,109	0,135	0,146	0,167	0,180	0,206	0,235	0,263	0,290	0,318	0,345	0,373	0,408	0,445	0,481	0,518
	0,25							0,37					0,55				

Fan test laboratory AMCA 210 Fig.12, Test Chamber. Performance certified is for installation type D - Ducted inlet, Ducted outlet. Performance ratings do not include the effects of appurtenances (accessories-belt cover, pulley & belt). Power rating (kW) does not include transmission losses.

The A-weighted sound ratings shown have been calculated per AMCA International Standard 301. Values shown are for inlet Lw(A) sound power levels for installation Type D: ducted inlet, ducted outlet. Ratings include the effects of duct end correction.



Performance Curve

AXV-F 560-168-6, 60Hz

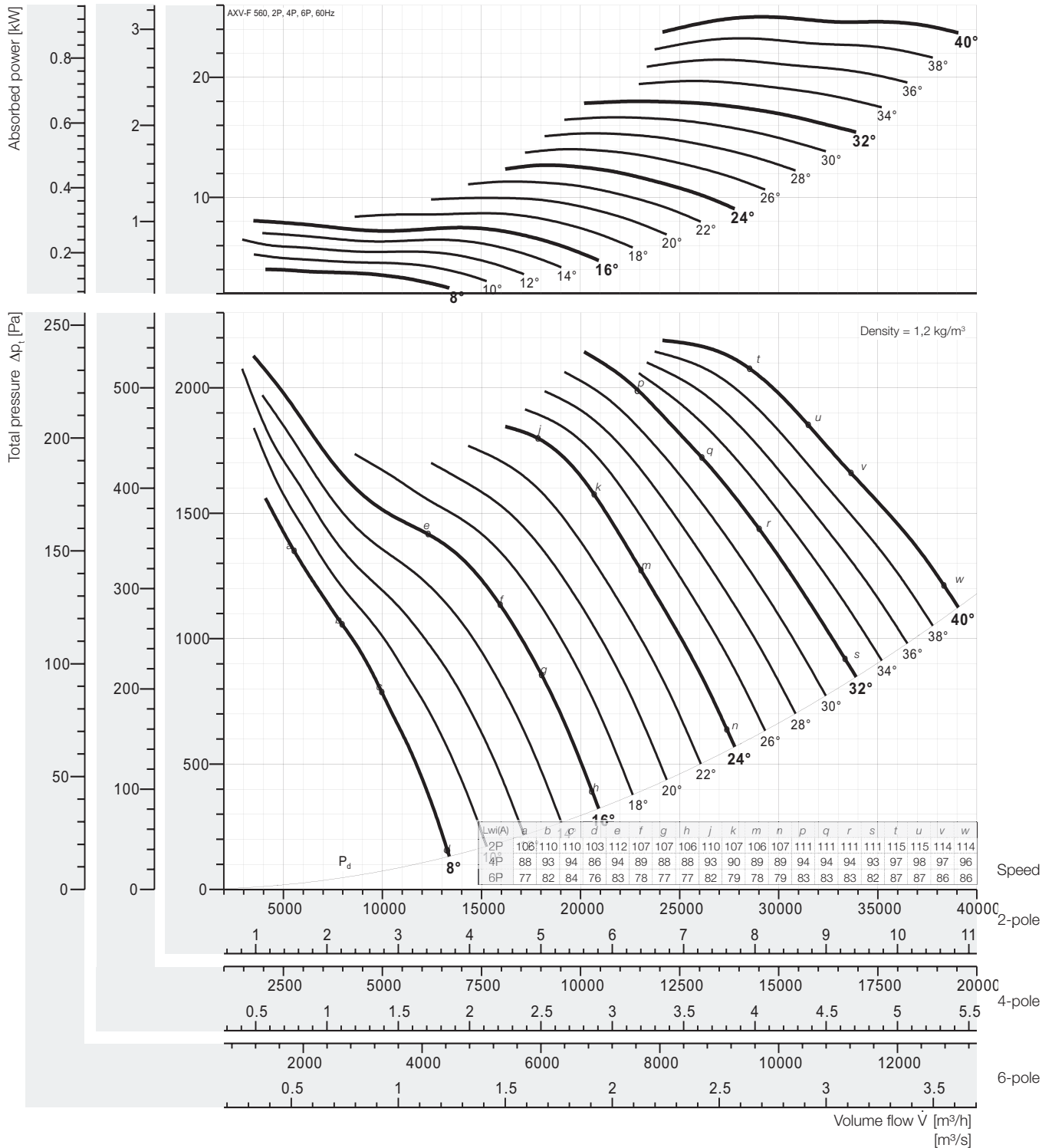

Peak absorbed power [kW]

2-pole = 3600 rpm; 4-pole = 1800 rpm; 6-pole = 1200 rpm;

N Poles	Pitch angle [°]																				
	8	10	12	14	16	18	20	22	24	26	28	30	32	34	36	38	40				
2P motor	4,024	5,261	6,499	7,037	8,065	8,689	9,962	11,32	12,69	14,02	15,34	16,67	18,00	19,69	2,146	23,24	25,03				
4P motor	0,503	0,658	0,812	0,880	1,008	1,086	1,245	1,415	1,587	1,752	1,918	2,084	2,250	2,461	2,682	2,905	3,128				
6P motor	0,149	0,195	0,241	0,261	0,299	0,322	0,369	0,419	0,470	0,519	0,568	0,617	0,667	0,729	0,795	0,861	0,927				

Fan test laboratory AMCA 210 Fig.12, Test Chamber. Performance certified is for installation type D - Ducted inlet, Ducted outlet. Performance ratings do not include the effects of appurtenances (accessories-belt cover, pulley & belt). Power rating (kW) does not include transmission losses.

The A-weighted sound ratings shown have been calculated per AMCA International Standard 301. Values shown are for inlet Lw(A) sound power levels for installation Type D: ducted inlet, ducted outlet. Ratings include the effects of duct end correction.



Performance Curve

AXV-F 630-200-6, 60Hz

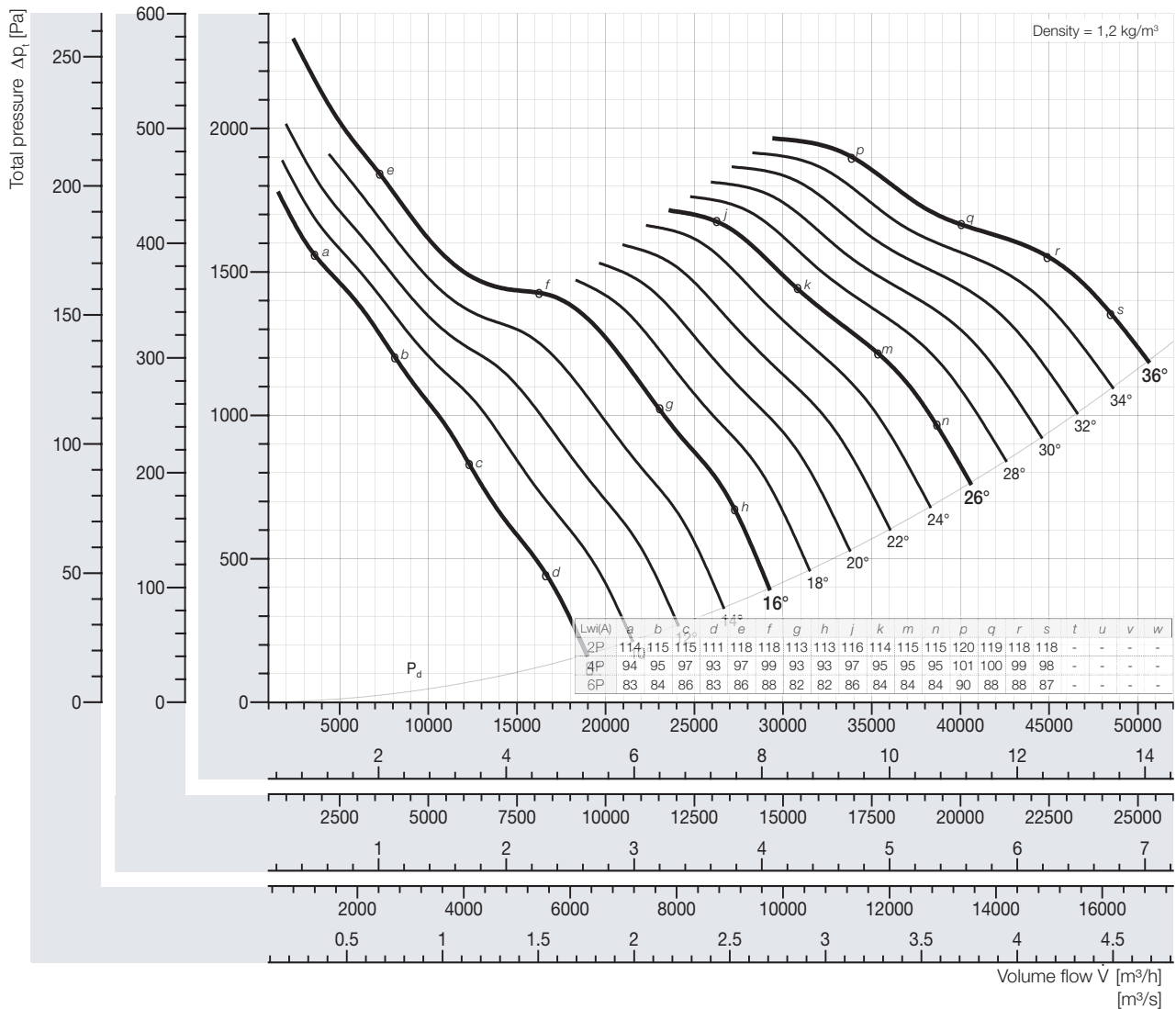
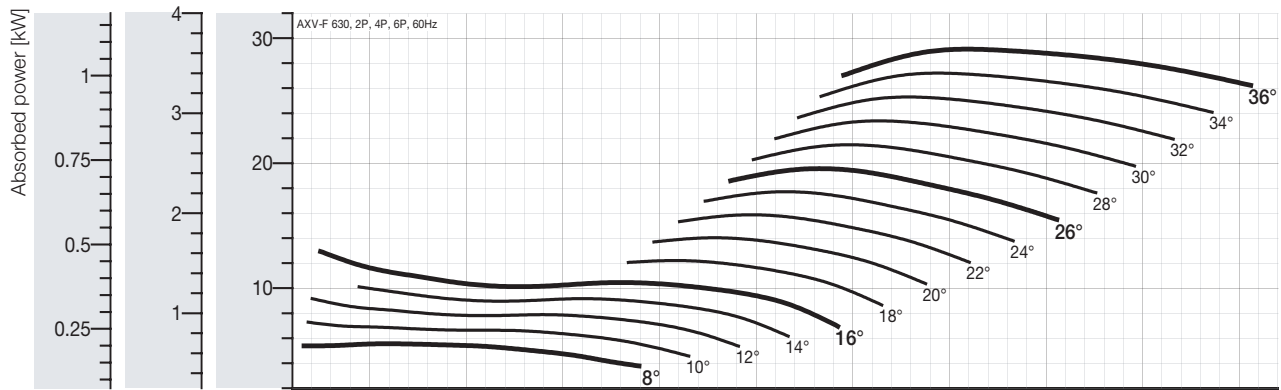

Peak absorbed power [kW]

2-pole = 3600 rpm; 4-pole = 1800 rpm; 6-pole = 1200 rpm;

N Poles	Pitch angle [°]																
	8	10	12	14	16	18	20	22	24	26	28	30	32	34	36	38	40
2P motor	5,549	7,281	9,169	11,06	12,94	12,2	14,03	15,86	17,69	19,52	21,41	23,30	25,19	27,18	29,10	-	-
	7,5		11	15				18,5		-*						-	-
4P motor	0,694	0,910	1,146	1,382	1,618	1,525	1,754	1,982	2,211	2,440	2,676	2,912	3,149	3,397	3,637	-	-
	0,75	1,1	1,5		2,2				3,0			4,0				-	-
6P motor	0,206	0,270	0,340	0,409	0,479	0,452	0,520	0,587	0,655	0,723	0,793	0,863	0,933	1,007	1,078	-	-
	0,37		0,55				0,75			1,1						-	-

Fan test laboratory AMCA 210 Fig.12, Test Chamber. Performance certified is for installation type D - Ducted inlet, Ducted outlet. Performance ratings do not include the effects of appurtenances (accessories-belt cover, pulley & belt). Power rating (kW) does not include transmission losses.

The A-weighted sound ratings shown have been calculated per AMCA International Standard 301. Values shown are for inlet Lw(A) sound power levels for installation Type D: ducted inlet, ducted outlet. Ratings include the effects of duct end correction.



Performance Curve

AXV-F 710-212-6, 60Hz

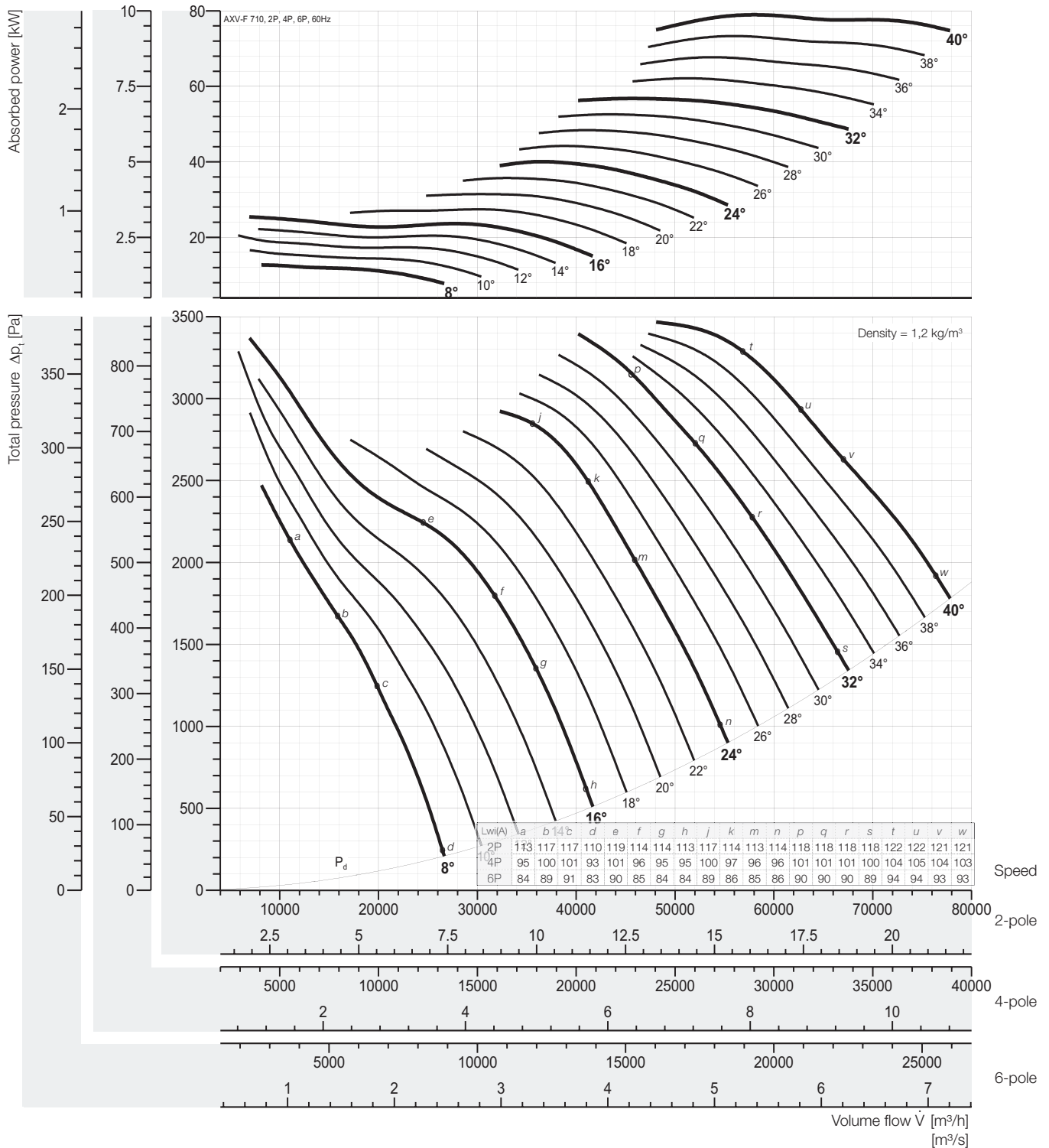

Peak absorbed power [kW]

2-pole = 3600 rpm; 4-pole = 1800 rpm; 6-pole = 1200 rpm;

N Poles	Pitch angle [°]																
	8	10	12	14	16	18	20	22	24	26	28	30	32	34	36	38	40
2P motor	12,70	16,60	20,50	22,20	25,45	27,41	31,43	35,72	40,05	44,22	48,40	52,59	56,78	62,12	67,71	73,32	78,95
	15	18,5	22	-*													
4P motor	1,587	2,075	2,563	2,775	3,181	3,427	3,929	4,465	5,006	5,527	6,050	6,574	7,098	7,765	8,463	9,165	9,87
	2,2		3,0		4,0			5,5		7,5				11			
6P motor	0,470	0,615	0,759	0,822	0,942	1,015	1,164	1,323	1,483	1,638	1,793	1,948	2,103	2,301	2,508	2,716	2,92
	0,55	0,75	1,1				1,5			2,2				3,0			

Fan test laboratory AMCA 210 Fig.12, Test Chamber. Performance certified is for installation type D - Ducted inlet, Ducted outlet. Performance ratings do not include the effects of appurtenances (accessories-belt cover, pulley & belt). Power rating (kW) does not include transmission losses.

The A-weighted sound ratings shown have been calculated per AMCA International Standard 301. Values shown are for inlet Lw(A) sound power levels for installation Type D: ducted inlet, ducted outlet. Ratings include the effects of duct end correction.



Performance Curve

AXV-F 800-238-6, 60Hz

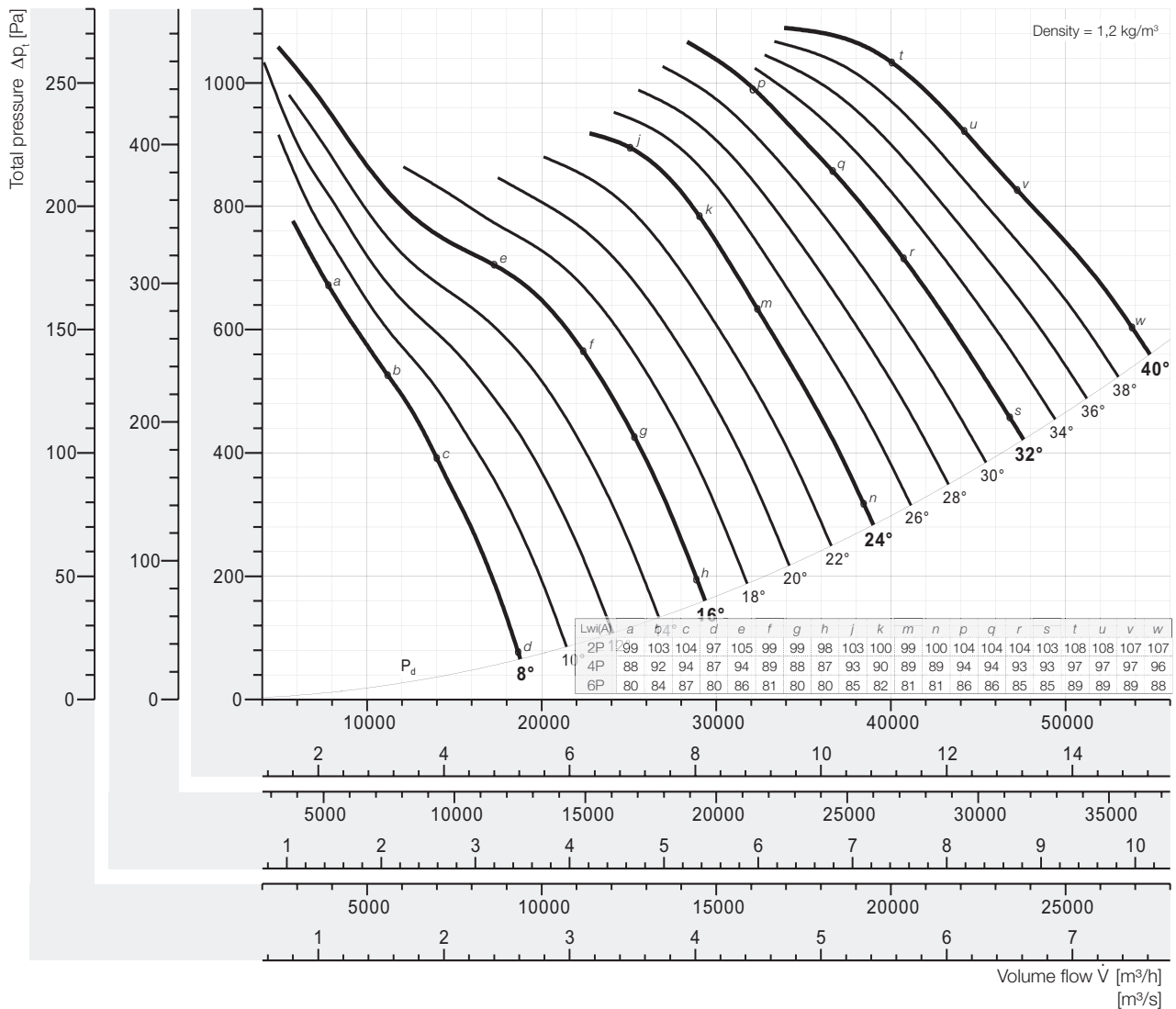
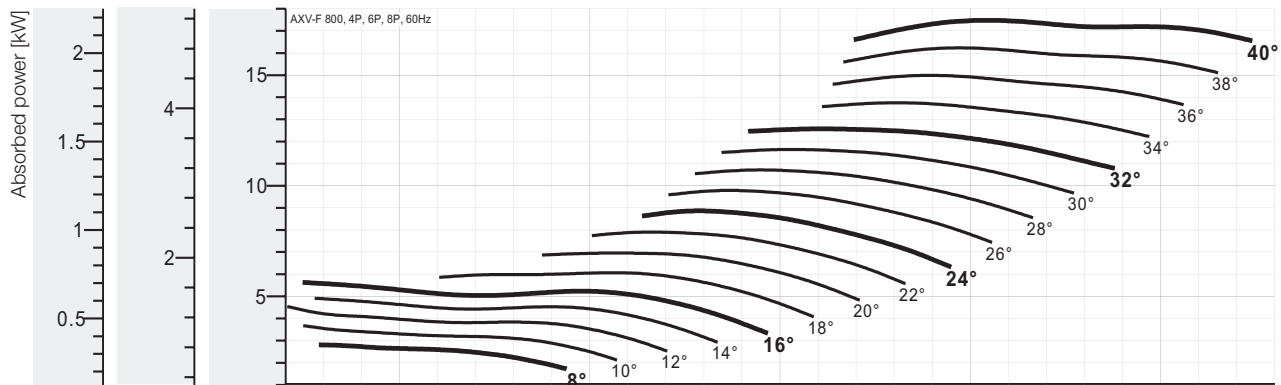

Speed
4-pole
6-pole
8-pole

Peak absorbed power [kW]

4-pole = 1800 rpm; 6-pole = 1200 rpm; 8-pole = 900 rpm;

N Poles	Pitch angle [°]																
	8	10	12	14	16	18	20	22	24	26	28	30	32	34	36	38	40
4P motor	2,810	3,674	4,538	4,915	5,633	6,068	6,957	7,908	8,864	9,788	10,71	11,64	12,57	13,75	14,99	16,23	17,48
	3,0	4,0	5,5		7,5			11				15				18,5	
6P motor	0,833	1,089	1,345	1,456	1,669	1,798	2,061	2,343	2,626	2,900	3,175	3,449	3,724	4,074	4,441	4,809	5,178
	1,1		1,5		2,2			3,0			4,0			5,5			
8P motor	0,351	0,459	0,567	0,614	0,704	0,759	0,870	0,988	1,108	1,224	1,339	1,455	1,571	1,719	1,873	2,029	2,185
	0,37	0,55	0,75			1,1			1,5				2,2				

Fan test laboratory AMCA 210 Fig.12, Test Chamber. Performance certified is for installation type D - Ducted inlet, Ducted outlet. Performance ratings do not include the effects of appurtenances (accessories-belt cover, pulley & belt). Power rating (kW) does not include transmission losses.

The A-weighted sound ratings shown have been calculated per AMCA International Standard 301. Values shown are for inlet Lw(A) sound power levels for installation Type D: ducted inlet, ducted outlet. Ratings include the effects of duct end correction.



Performance Curve

AXV-F 900, 4P, 6P, 8P, 60Hz

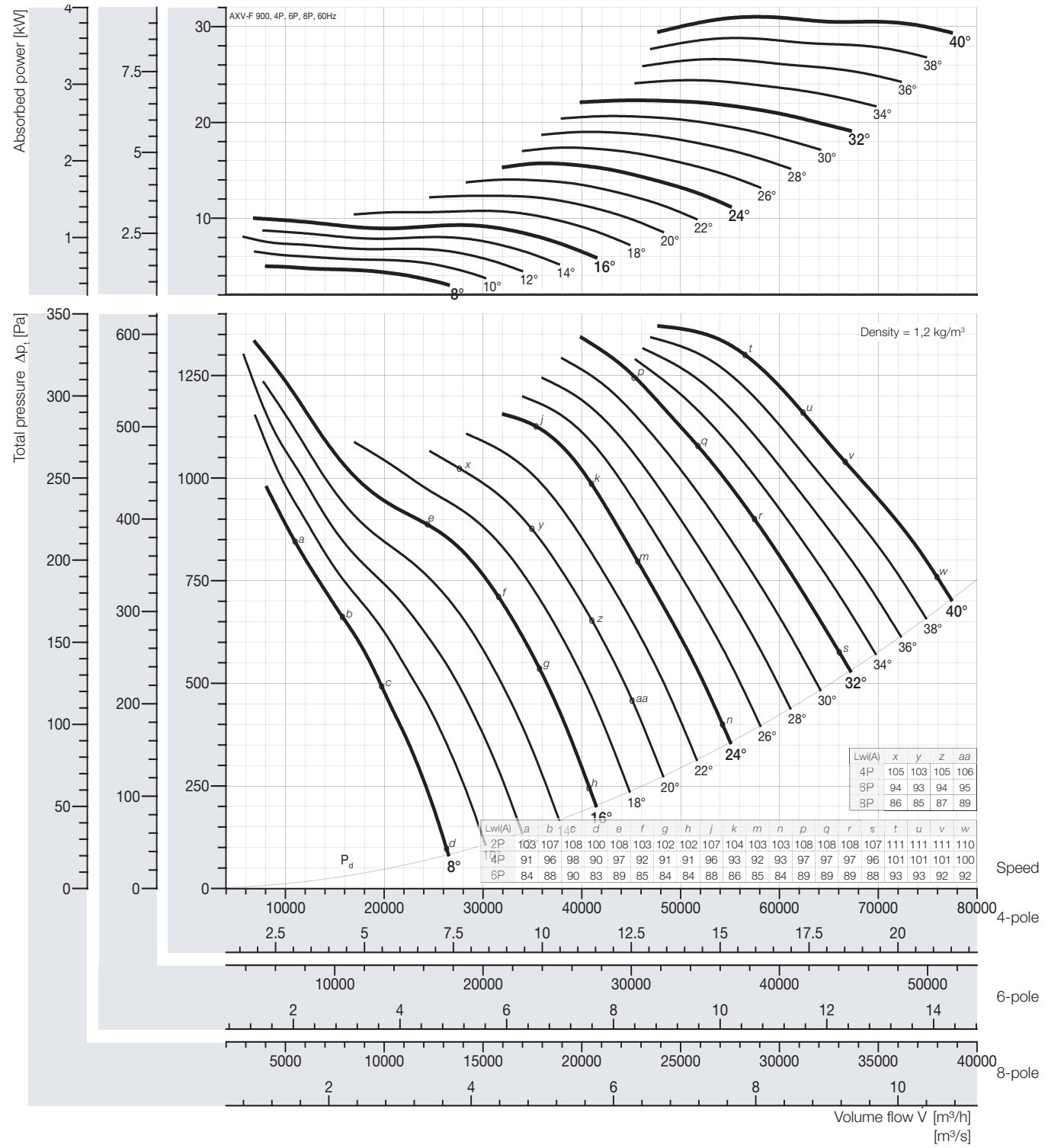

Peak absorbed power [kW]

4-pole = 1800 rpm; 6-pole = 1200 rpm; 8-pole = 900 rpm;

N Poles	Pitch angle [°]																
	8	10	12	14	16	18	20	22	24	26	28	30	32	34	36	38	40
4P motor	4,990	6,524	8,058	8,726	10,00	10,77	12,35	14,04	15,74	17,38	19,02	20,67	22,32	24,41	26,61	28,82	31,03
6P motor	1,478	1,933	2,388	2,585	2,963	3,192	3,660	4,160	4,663	5,149	5,636	6,124	6,612	7,234	7,884	8,538	9,194
8P motor	0,624	0,815	1,007	1,091	1,250	1,347	1,544	1,755	1,967	2,172	2,378	2,584	2,789	3,052	3,326	3,602	3,879

Fan test laboratory AMCA 210 Fig.12, Test Chamber. Performance certified is for installation type D - Ducted inlet, Ducted outlet. Performance ratings do not include the effects of appurtenances (accessories-belt cover, pulley & belt). Power rating (kW) does not include transmission losses.

The A-weighted sound ratings shown have been calculated per AMCA International Standard 301. Values shown are for inlet Lw(A) sound power levels for installation Type D: ducted inlet, ducted outlet. Ratings include the effects of duct end correction.



Performance Curve

AXV-F 1000-420-6, 60Hz

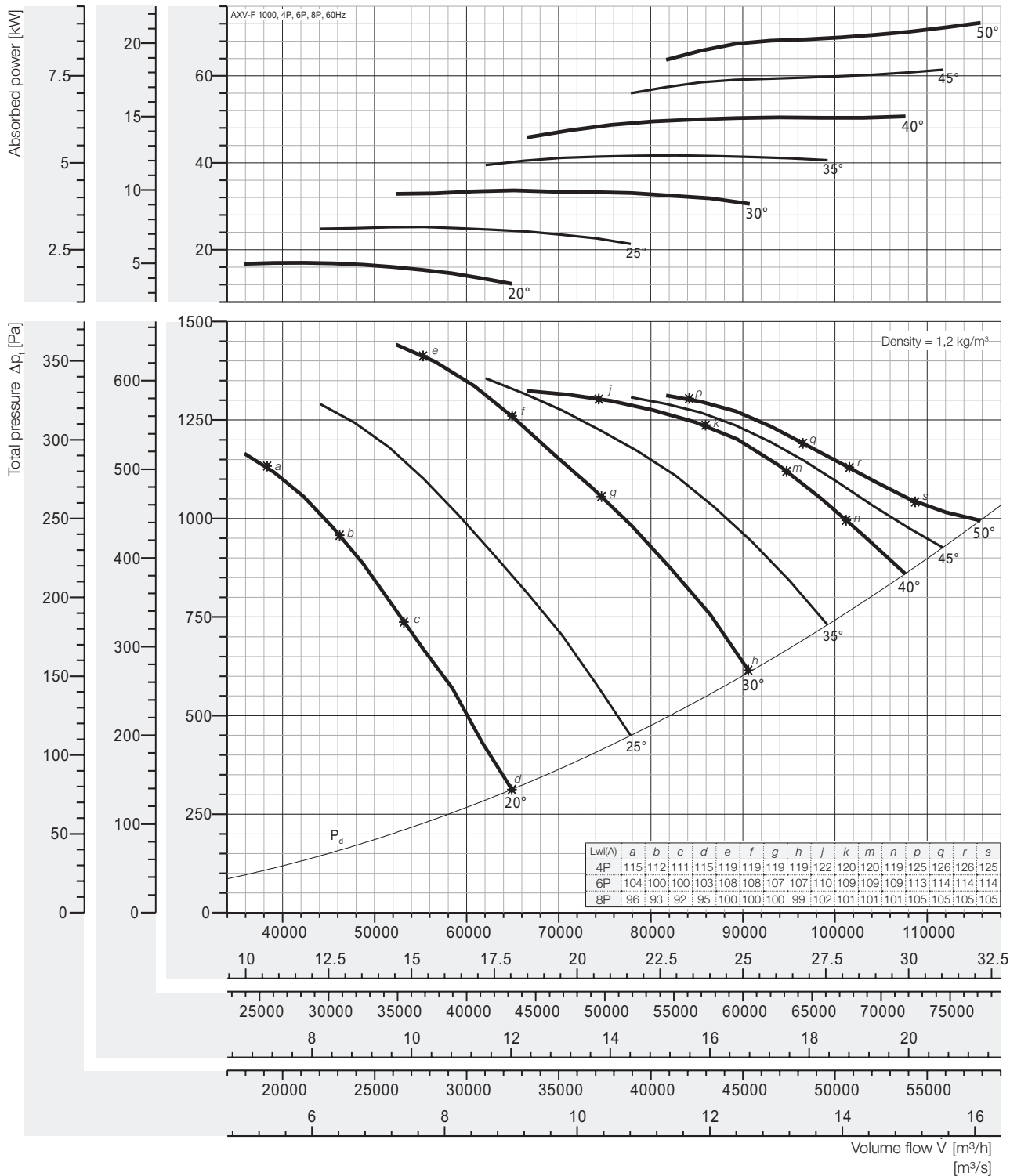

Peak absorbed power [kW]

4-pole = 1800 rpm; 6-pole = 1200 rpm; 8-pole = 900 rpm;

N Poles	Pitch angle [°]						
	20	25	30	35	40	45	50
4P motor	17,03	25,25	33,68	41,75	50,67	61,43	72,19
6P motor	5,045	7,482	9,980	12,37	15,01	18,20	21,39
8P motor	2,128	3,156	4,210	5,219	6,333	7,678	9,023

Fan test laboratory AMCA 210 Fig.12, Test Chamber. Performance certified is for installation type D - Ducted inlet, Ducted outlet. Performance ratings do not include the effects of appurtenances (accessories-belt cover, pulley & belt). Power rating (kW) does not include transmission losses.

The A-weighted sound ratings shown have been calculated per AMCA International Standard 301. Values shown are for inlet Lw(A) sound power levels for installation Type D: ducted inlet, ducted outlet. Ratings include the effects of duct end correction.



Performance Curve

AXV-F 1120-472-6, 60Hz

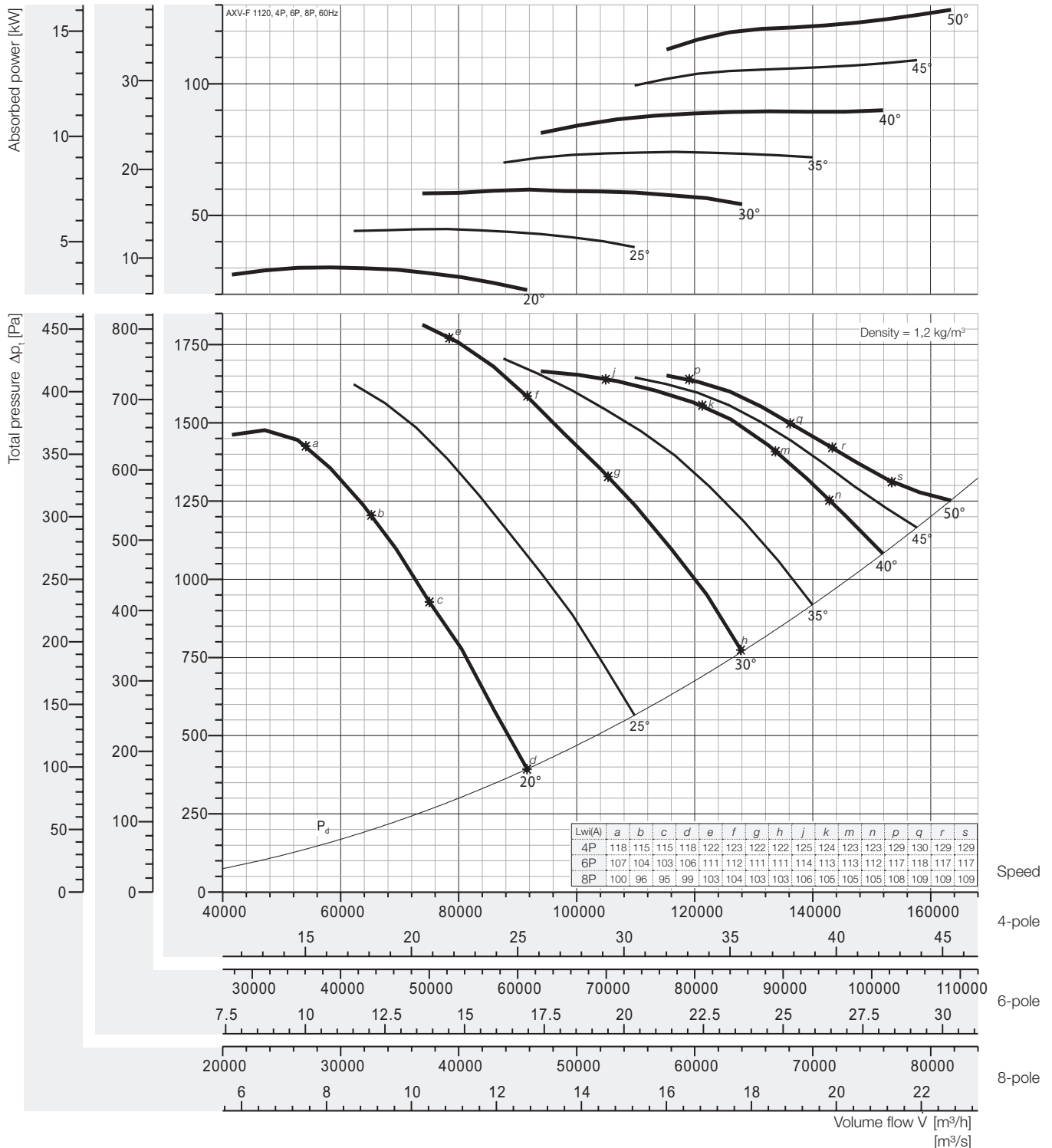

Peak absorbed power [kW]

4-pole = 1800 rpm; 6-pole = 1200 rpm; 8-pole = 900 rpm;

N Poles	Pitch angle [°]						
	20	25	30	35	40	45	50
4P motor	30,25	44,83	59,80	74,12	89,94	109,0	128,1
	37	45	75		90	110	132
6P motor	8,964	13,28	17,72	21,96	26,65	32,31	37,97
	11	15	18,5	22	30	37	45
8P motor	3,782	5,603	7,475	9,265	11,24	13,63	16,02
	4	7,5		11	15		18,5

Fan test laboratory AMCA 210 Fig.12, Test Chamber. Performance certified is for installation type D - Ducted inlet, Ducted outlet. Performance ratings do not include the effects of appurtenances (accessories-belt cover, pulley & belt). Power rating (kW) does not include transmission losses.

The A-weighted sound ratings shown have been calculated per AMCA International Standard 301. Values shown are for inlet Lw(A) sound power levels for installation Type D: ducted inlet, ducted outlet. Ratings include the effects of duct end correction.



Performance Curve

AXV-F 1250-525-6, 60Hz

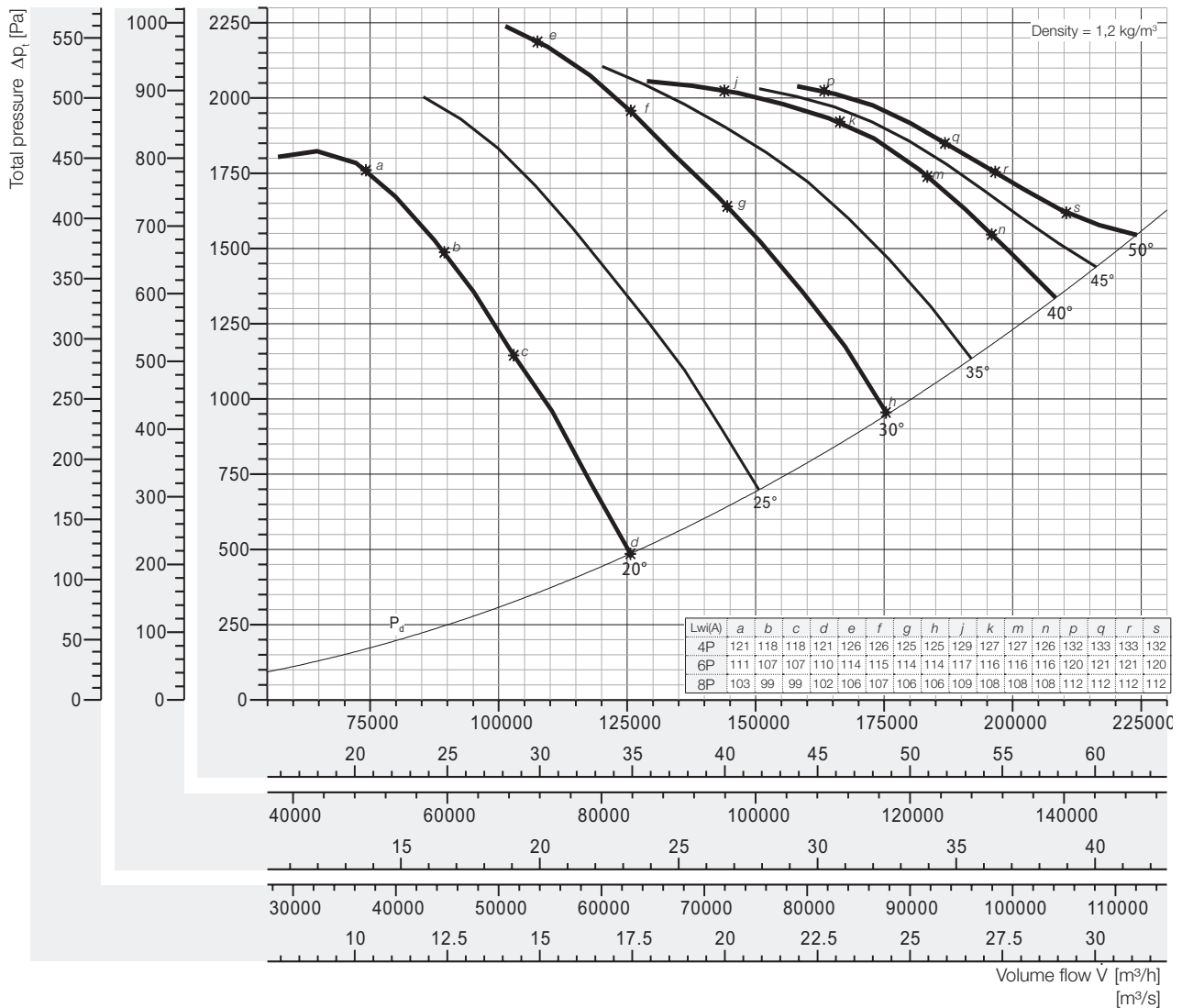
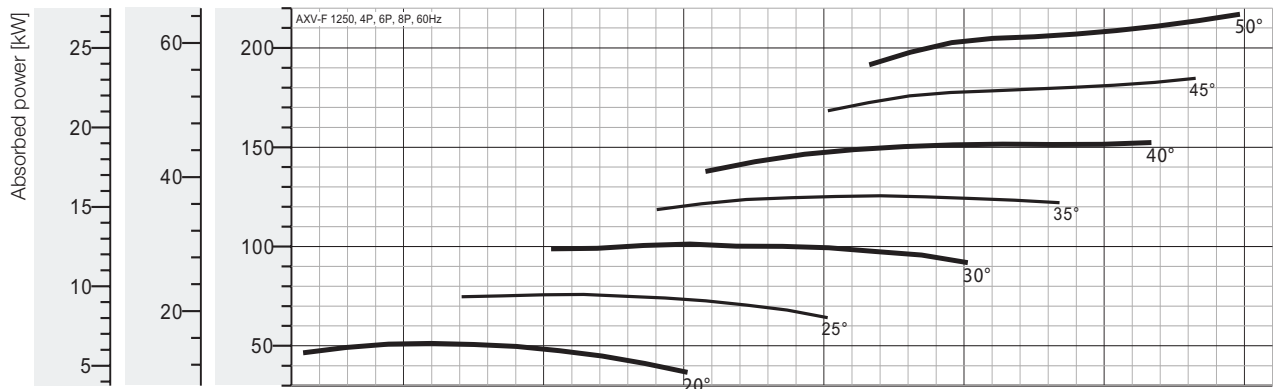

Peak absorbed power [kW]

4-pole = 1800 rpm; 6-pole = 1200 rpm; 8-pole = 900 rpm;

N Poles	Pitch angle [°]						
	20	25	30	35	40	45	50
4P motor	51,23	75,91	101,3	125,5	152,3	184,7	217,0
6P motor	15,18	22,49	30,00	37,19	45,13	54,72	64,30
8P motor	6,404	9,489	12,66	15,69	19,04	23,08	27,13

Fan test laboratory AMCA 210 Fig.12, Test Chamber. Performance certified is for installation type D - Ducted inlet, Ducted outlet. Performance ratings do not include the effects of apertures (accessories-belt cover, pulley & belt). Power rating (kW) does not include transmission losses.

The A-weighted sound ratings shown have been calculated per AMCA International Standard 301. Values shown are for inlet Lw(A) sound power levels for installation Type D: ducted inlet, ducted outlet. Ratings include the effects of duct end correction.



Performance Curve

AXV-F 1400-550-7, 60Hz

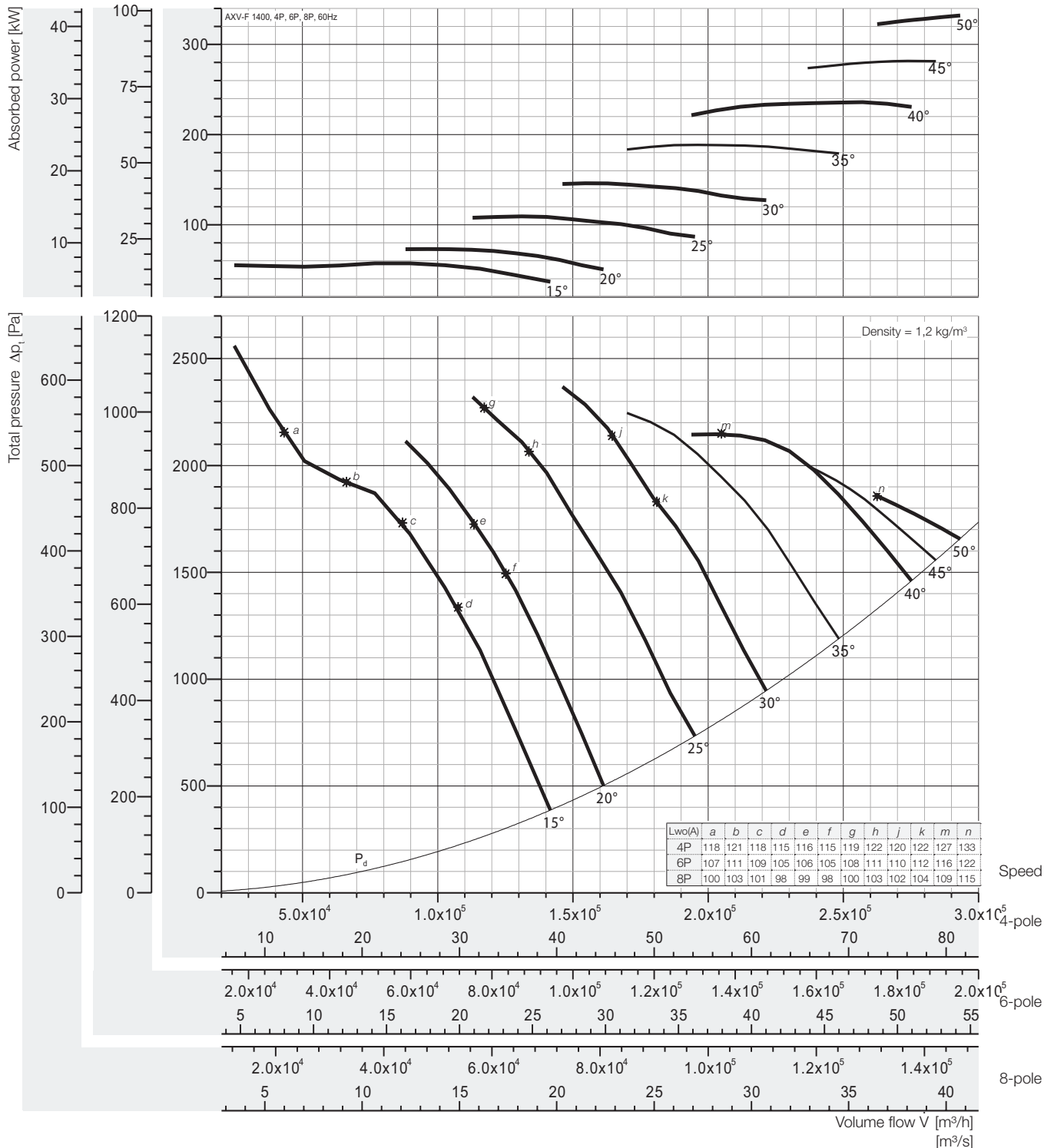

Peak absorbed power [kW]

4-pole = 1800 rpm; 6-pole = 1200 rpm; 8-pole = 900 rpm;

N Poles	Pitch angle [°]							
	15	20	25	30	35	40	45	50
4P motor	57,26	73,06	109,3	146,0	188,7	235,9	281,8	332,3
	75		110	160	200	250	315	355
6P motor	16,97	21,65	32,39	43,27	55,91	69,89	83,49	98,46
	18,5	22	37	45	75	90	110	
8P motor	7,158	9,133	13,67	18,25	23,59	29,49	35,22	41,54
	7,5	11	15	18,5	30		37	45

Fan test laboratory AMCA 210 Fig.15, Test Chamber. Performance certified is for installation type A - Free inlet, Free outlet with partition. Performance ratings do not include the effects of appurtenances (accessories-belt cover, pulley & belt). Power rating (kW) does not include transmission losses.

The A-weighted sound ratings shown have been calculated per AMCA International Standard 301. Values shown are for outlet LwoA sound power levels for installation Type A: free inlet, free outlet.



Performance Curve

AXV-F 1600-625-7, 60Hz

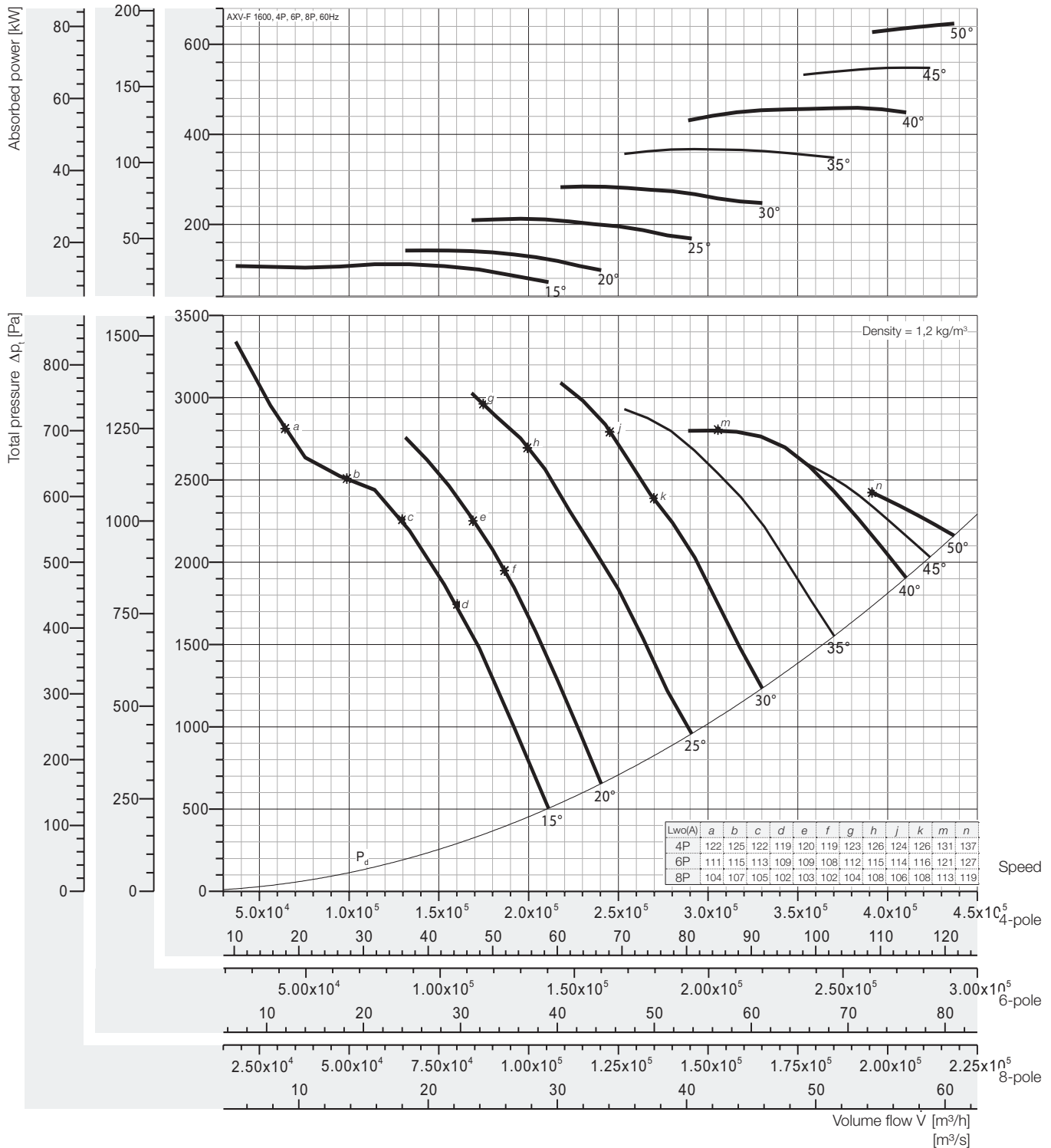

Peak absorbed power [kW]

4-pole = 1800 rpm; 6-pole = 1200 rpm; 8-pole = 900 rpm;

N Poles	Pitch angle [°]							
	15	20	25	30	35	40	45	50
4P	111,4	142,1	212,7	284,1	367,1	458,9	548,2	646,4
motor	132	160	250	315	400	-	-	-
6P	33,01	42,11	63,01	84,17	108,8	136,0	162,4	191,5
motor	37	45	75	90	110	160	200	
8P	13,92	17,77	26,58	35,51	45,89	57,36	68,52	80,80
motor	15	18,5	30	37	55	75		90

Fan test laboratory AMCA 210 Fig.15, Test Chamber. Performance certified is for installation type A - Free inlet, Free outlet with partition. Performance ratings do not include the effects of appurtenances (accessories-belt cover, pulley & belt). Power rating (kW) does not include transmission losses.

The A-weighted sound ratings shown have been calculated per AMCA International Standard 301. Values shown are for outlet Lw(A) sound power levels for installation Type A: free inlet, free outlet.



Performance Curve

AXV-F 1800-710-7, 60Hz

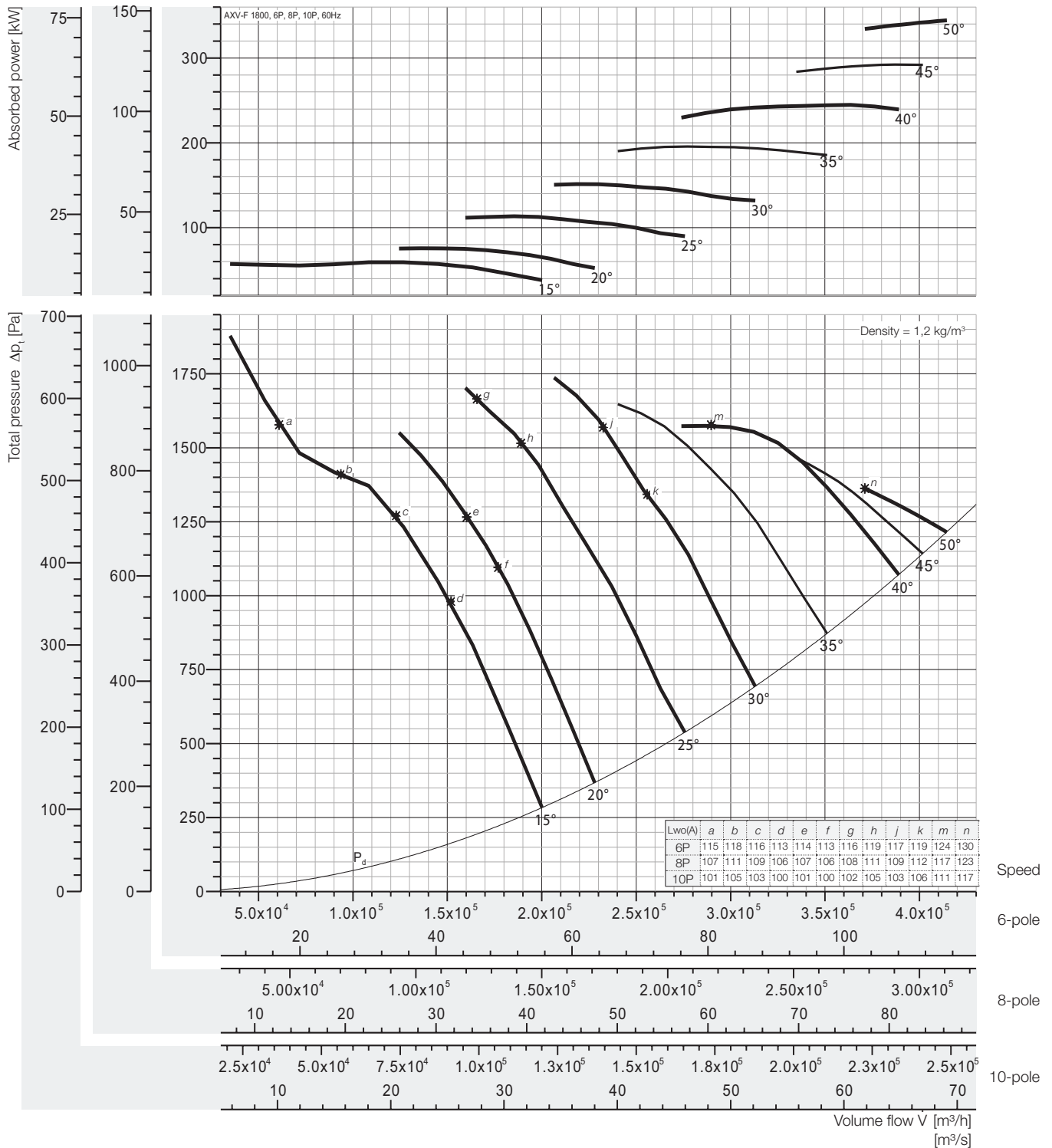

Peak absorbed power [kW]

6-pole = 1200 rpm; 8-pole = 900 rpm; 10-pole = 720 rpm;

N Poles	Pitch angle [°]							
	15	20	25	30	35	40	45	50
6P motor	59,37	75,76	113,3	151,4	195,7	244,6	292,2	344,5
8P motor	25,05	31,96	47,82	63,88	82,55	103,2	123,3	145,3
10P motor	12,82	16,36	24,49	32,70	42,26	52,83	63,11	74,42

Fan test laboratory AMCA 210 Fig.15, Test Chamber. Performance certified is for installation type A - Free inlet, Free outlet with partition. Performance ratings do not include the effects of appurtenances (accessories-belt cover, pulley & belt). Power rating (kW) does not include transmission losses.

The A-weighted sound ratings shown have been calculated per AMCA International Standard 301. Values shown are for outlet LwoA sound power levels for installation Type A: free inlet, free outlet.



Performance Curve

AXV-F 2000-785-7, 60Hz

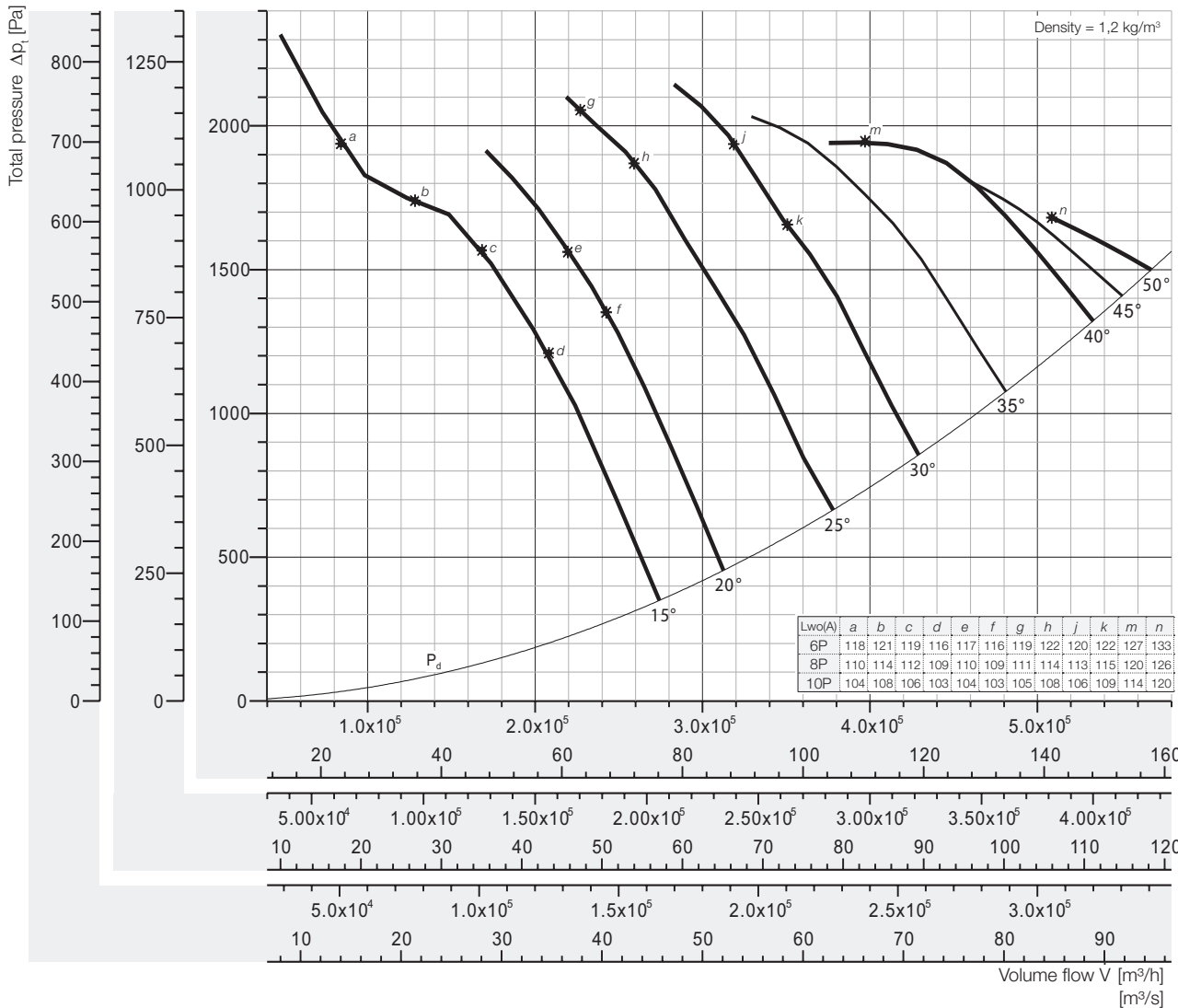
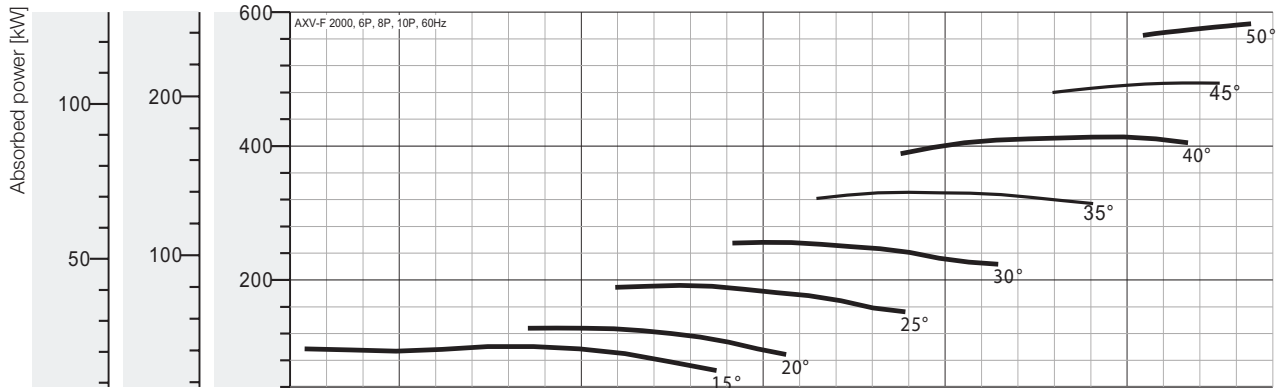

Peak absorbed power [kW]

6-pole = 1200 rpm; 8-pole = 900 rpm; 10-pole = 720 rpm;

N Poles	Pitch angle [°]							
	15	20	25	30	35	40	45	50
6P motor	100,4	128,1	191,7	256,1	330,9	413,6	494,1	582,7
8P motor	42,36	54,05	80,88	108,0	139,6	174,5	208,4	245,8
10P motor	21,69	27,67	41,41	55,31	71,47	89,35	106,7	125,9

Fan test laboratory AMCA 210 Fig.15, Test Chamber. Performance certified is for installation type A - Free inlet, Free outlet with partition. Performance ratings do not include the effects of appurtenances (accessories-belt cover, pulley & belt). Power rating (kW) does not include transmission losses.

The A-weighted sound ratings shown have been calculated per AMCA International Standard 301. Values shown are for outlet Lw0A sound power levels for installation Type A: free inlet, free outlet.



Performance Curve

AXV-F 2200-862-7, 60Hz

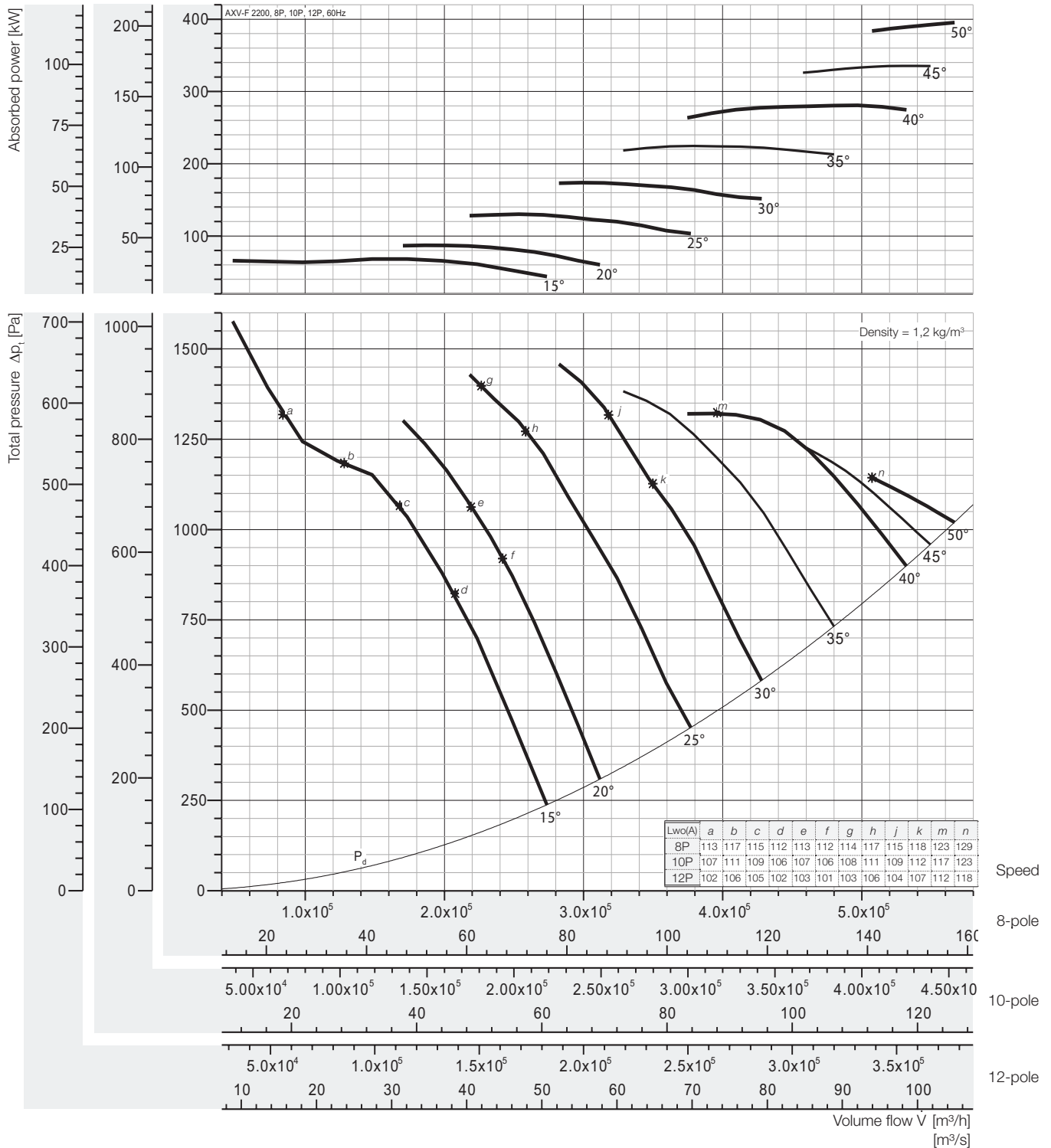

Peak absorbed power [kW]

8-pole = 900 rpm; 10-pole = 720 rpm; 12-pole = 600 rpm;

N Poles	Pitch angle [°]							
	15	20	25	30	35	40	45	50
8P motor	68,45	86,95	130,1	173,8	224,6	280,7	335,3	395,4
	75	90	132	200	250	315	355	400
10P motor	34,89	44,52	66,61	88,97	115,0	143,7	171,7	202,5
	37	45	75	90	132	160	200	250
12P motor	20,19	25,76	38,55	51,49	66,54	83,18	99,36	117,2
	22	30	45	55	75	90	110	132

Fan test laboratory AMCA 210 Fig.15, Test Chamber. Performance certified is for installation type A - Free inlet, Free outlet with partition. Performance ratings do not include the effects of appurtenances (accessories-belt cover, pulley & belt). Power rating (kW) does not include transmission losses.

The A-weighted sound ratings shown have been calculated per AMCA International Standard 301. Values shown are for outlet LwoA sound power levels for installation Type A: free inlet, free outlet.



Performance Curve

AXV-F 2400-942-7, 60Hz

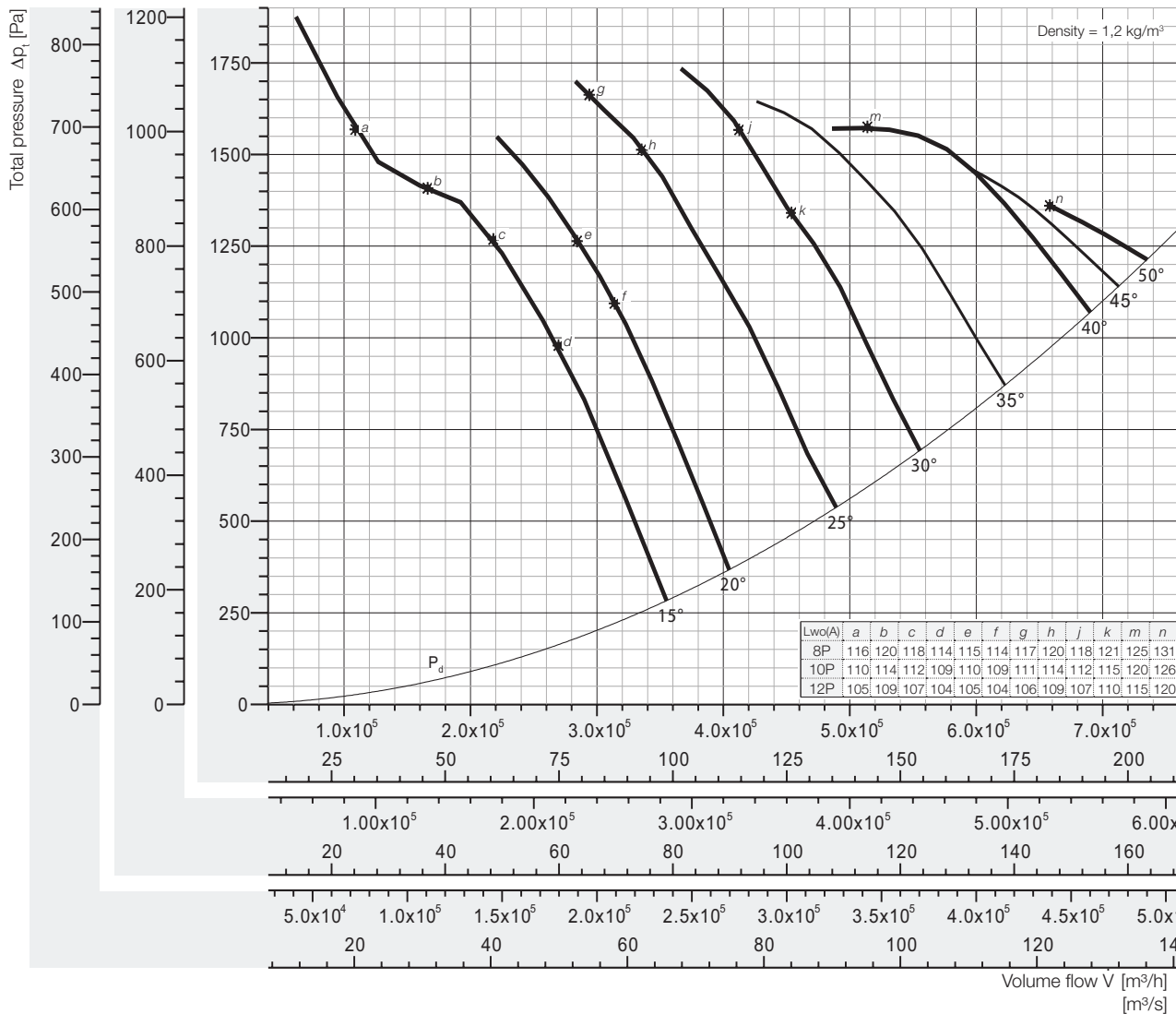
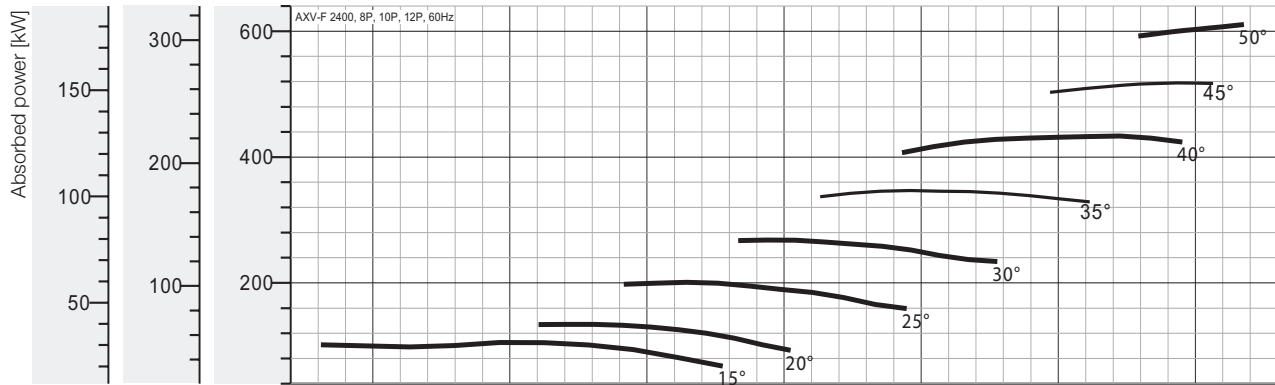

Speed
8-pole
10-pole
12-pole

Peak absorbed power [kW]

8-pole = 900 rpm; 10-pole = 720 rpm; 12-pole = 600 rpm;

N Poles	Pitch angle [°]							
	15	20	25	30	35	40	45	50
8P motor	105,2 110	134,2 160	200,8 250	268,2 315	346,6 355	433,3 450	517,6 560	610,4 630
10P motor	53,86 55	68,72 75	102,8 110	137,3 160	177,5 200	221,9 250	265,0 315	312,5
12P motor	31,17 37	39,77 45	59,50 75	79,48 90	102,7 110	128,4 132	153,4 160	180,9 200

Fan test laboratory AMCA 210 Fig.15, Test Chamber. Performance certified is for installation type A - Free inlet, Free outlet with partition. Performance ratings do not include the effects of appurtenances (accessories-belt cover, pulley & belt). Power rating (kW) does not include transmission losses.

The A-weighted sound ratings shown have been calculated per AMCA International Standard 301. Values shown are for outlet Lw0A sound power levels for installation Type A: free inlet, free outlet.



Performance Curve

AXV-F 2500-980-7, 60Hz

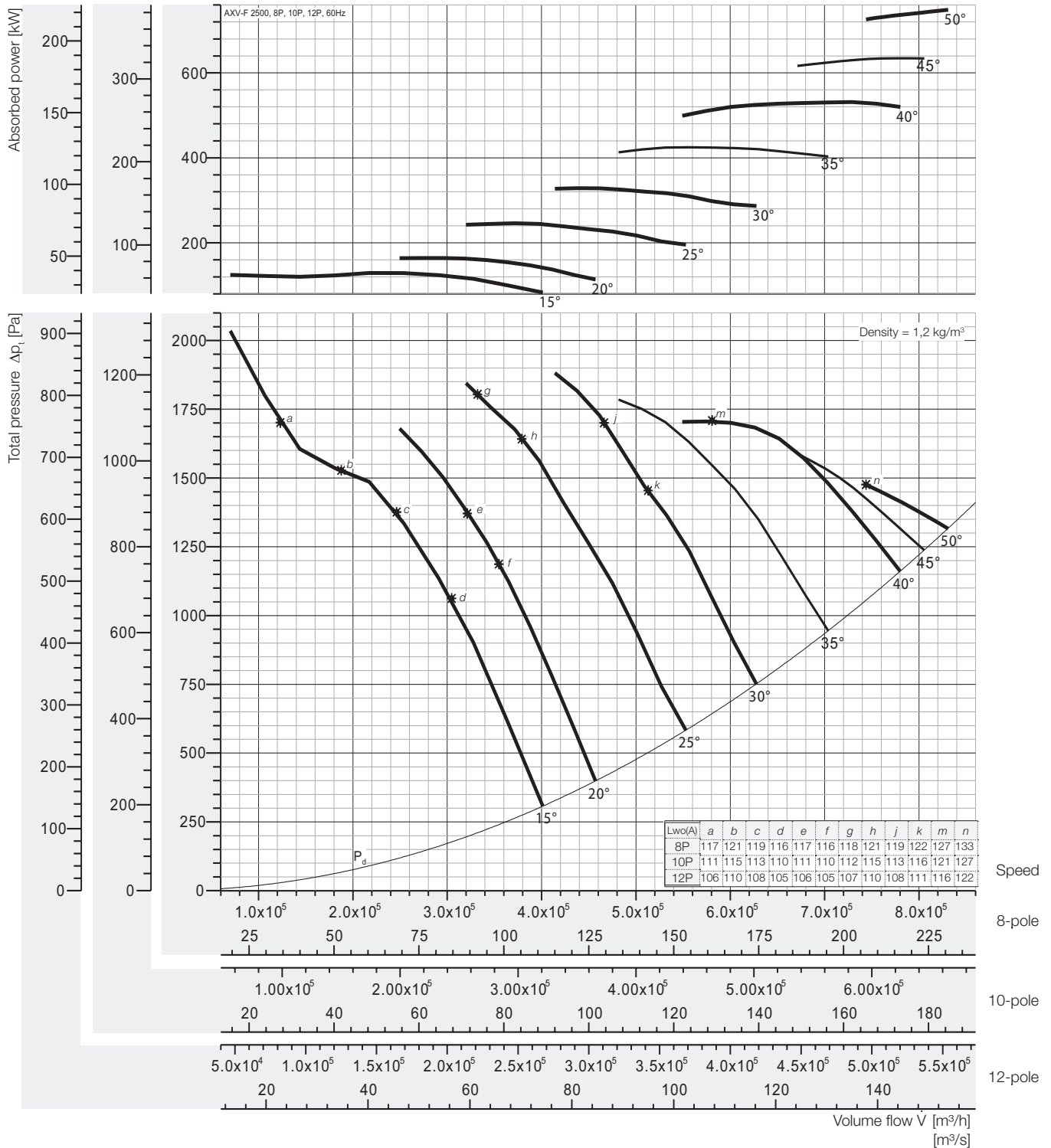

Peak absorbed power [kW]

8-pole = 900 rpm; 10-pole = 720 rpm; 12-pole = 600 rpm;

N Poles	Pitch angle [°]							
	15	20	25	30	35	40	45	50
8P	128,9	164,5	246,2	328,8	425,0	531,2	634,6	748,3
motor	132	200	250	355	450	560	710	-
10P	66,02	84,24	126,0	168,4	217,6	272,0	324,9	383,1
motor	75	90	132	200	250	315	355	400
12P	38,21	48,75	72,95	97,43	125,9	157,4	188,0	221,7
motor	45	55	75	110	132	160	200	250

Fan test laboratory AMCA 210 Fig.15, Test Chamber. Performance certified is for installation type A - Free inlet, Free outlet with partition. Performance ratings do not include the effects of appurtenances (accessories-belt cover, pulley & belt). Power rating (kW) does not include transmission losses.

The A-weighted sound ratings shown have been calculated per AMCA International Standard 301. Values shown are for outlet LwoA sound power levels for installation Type A: free inlet, free outlet.



Performance Curve

AXV-F 2600-1020-7, 60Hz

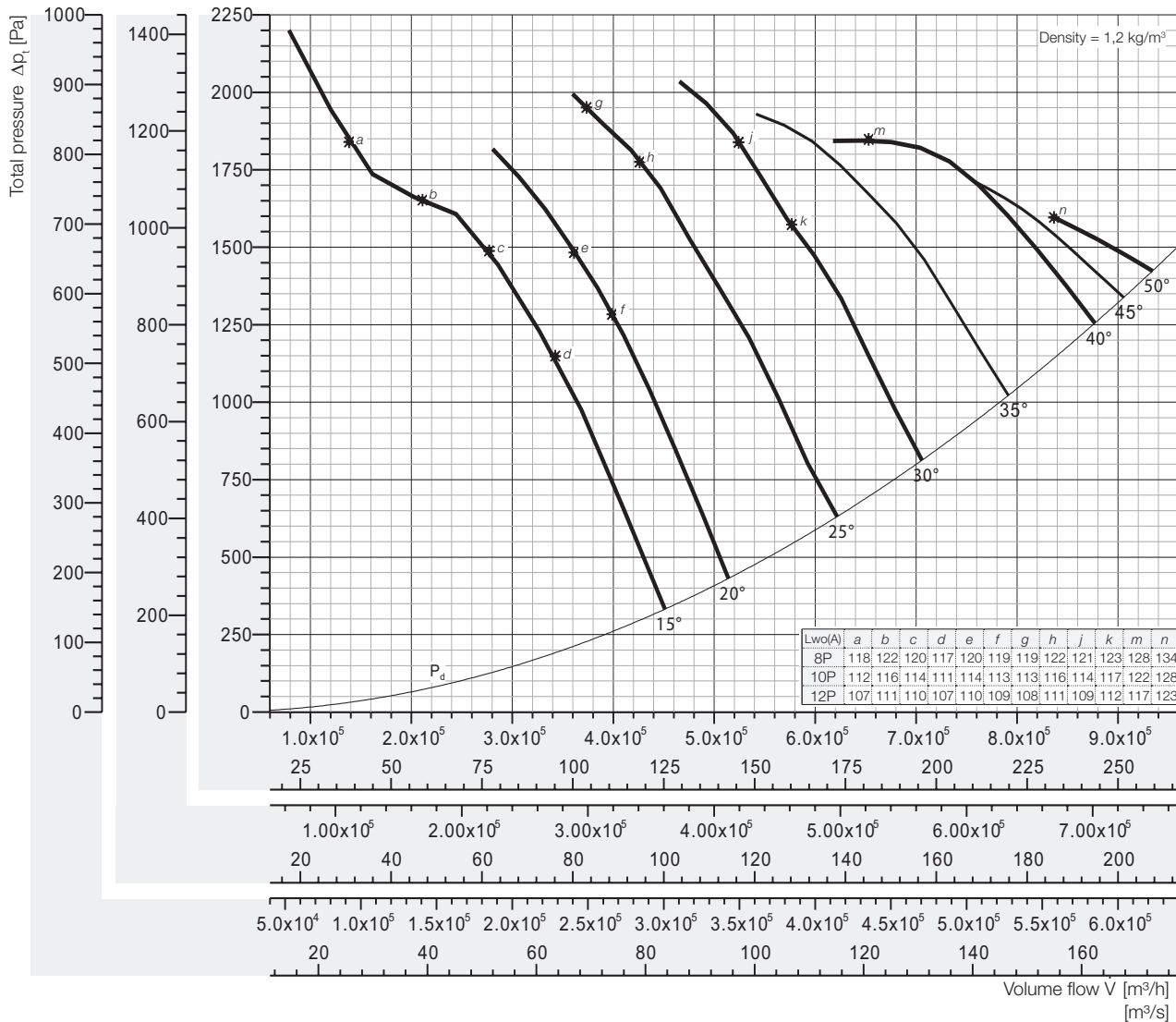
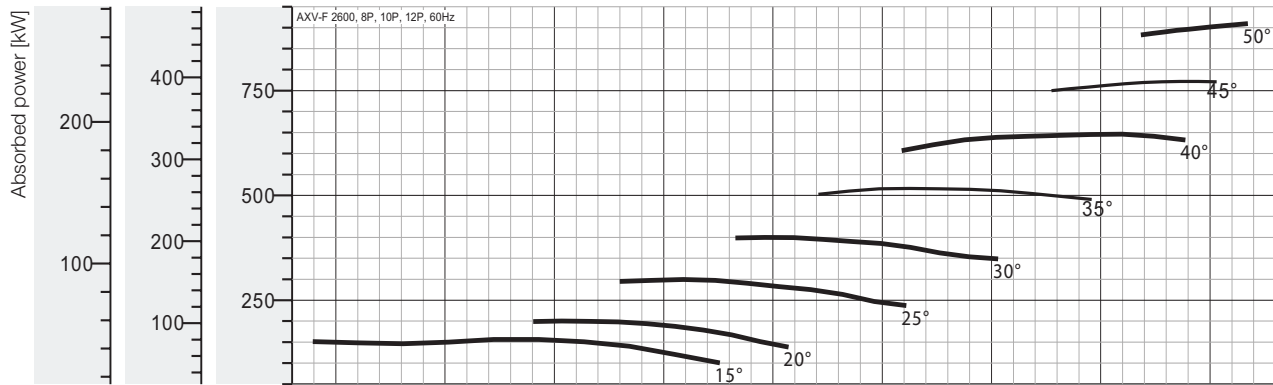

Speed
8-pole
10-pole
12-pole

Peak absorbed power [kW]

8-pole = 900 rpm; 10-pole = 720 rpm; 12-pole = 600 rpm;

N Poles	Pitch angle [°]							
	15	20	25	30	35	40	45	50
8P motor	156,8	200,1	299,4	399,9	516,8	646,1	771,8	910,1
10P motor	80,30	102,4	153,3	204,8	264,6	330,8	395,1	466,0
12P motor	46,47	59,29	88,72	118,5	153,1	191,4	228,7	269,6

Fan test laboratory AMCA 210 Fig.15, Test Chamber. Performance certified is for installation type A - Free inlet, Free outlet with partition. Performance ratings do not include the effects of appurtenances (accessories-belt cover, pulley & belt). Power rating (kW) does not include transmission losses.

The A-weighted sound ratings shown have been calculated per AMCA International Standard 301. Values shown are for outlet LwoA sound power levels for installation Type A: free inlet, free outlet.



Performance Curve

AXV-F 2800-1095-7, 60Hz **wolter**

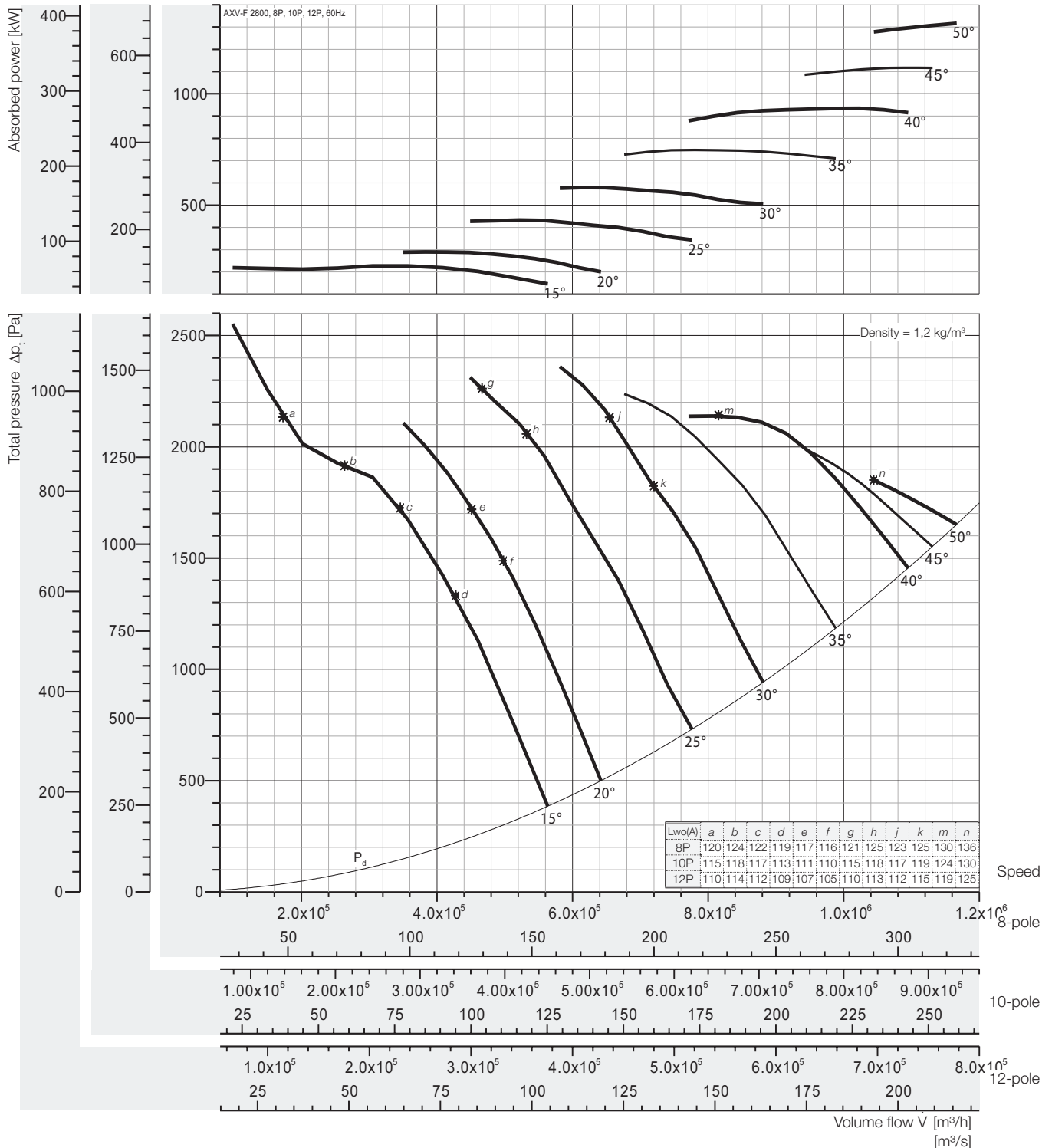

Peak absorbed power [kW]

8-pole = 900 rpm; 10-pole = 720 rpm; 12-pole = 600 rpm;

N Poles	Pitch angle [°]							
	15	20	25	30	35	40	45	50
8P	227,0	289,6	433,4	578,9	748,1	935,2	1117	1317
motor	250	315	450	630	-	-	-	-
10P	116,2	148,3	221,9	296,4	383,0	478,8	572,0	674,5
motor	132	160	250	315	400	500	630	710
12P	67,26	85,82	128,4	171,5	221,7	277,1	331,0	390,3
motor	75	90	132	200	250	315	355	400

Fan test laboratory AMCA 210 Fig.15, Test Chamber. Performance certified is for installation type A - Free inlet, Free outlet with partition. Performance ratings do not include the effects of appurtenances (accessories-belt cover, pulley & belt). Power rating (kW) does not include transmission losses.

The A-weighted sound ratings shown have been calculated per AMCA International Standard 301. Values shown are for outlet LwoA sound power levels for installation Type A: free inlet, free outlet.



Direct Driven Models, Size from 500 to 2800, 60Hz

Model: AXV-F 500-150-6

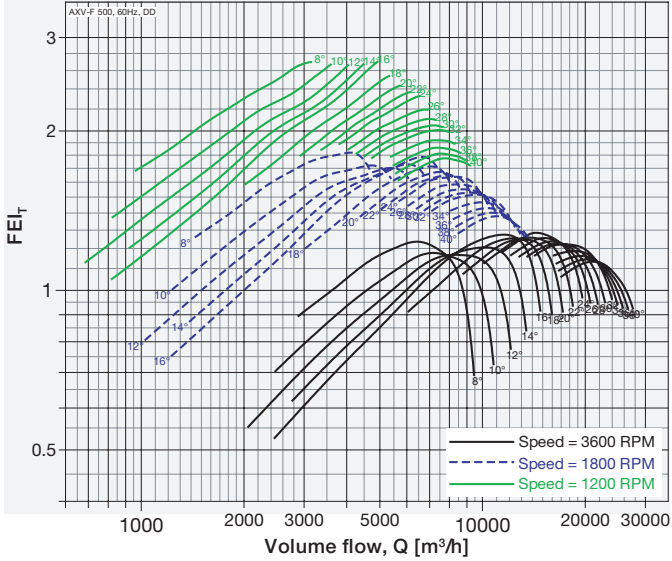

Model: AXV-F 560-168-6

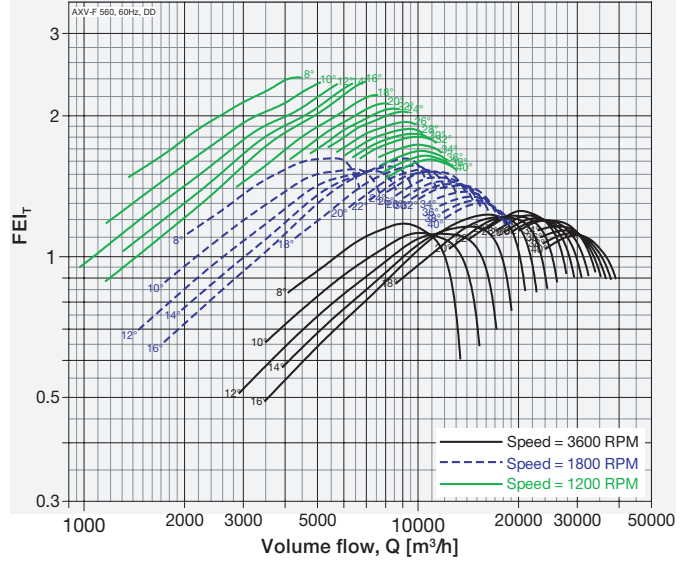

Model: AXV-F 630-200-6

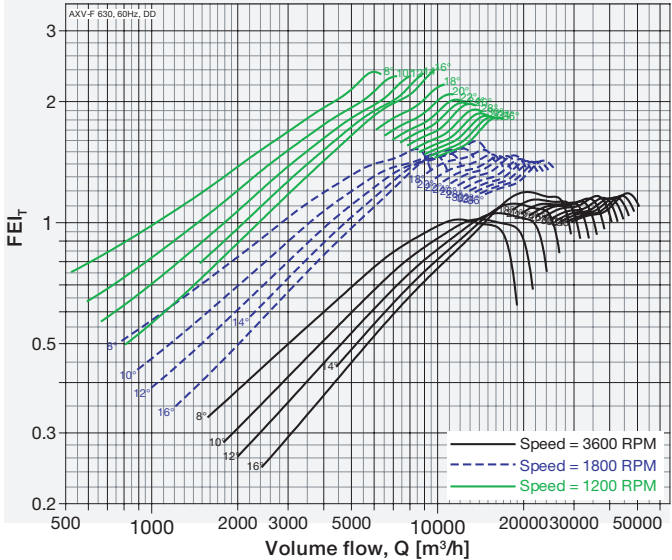

Model: AXV-F 710-212-6

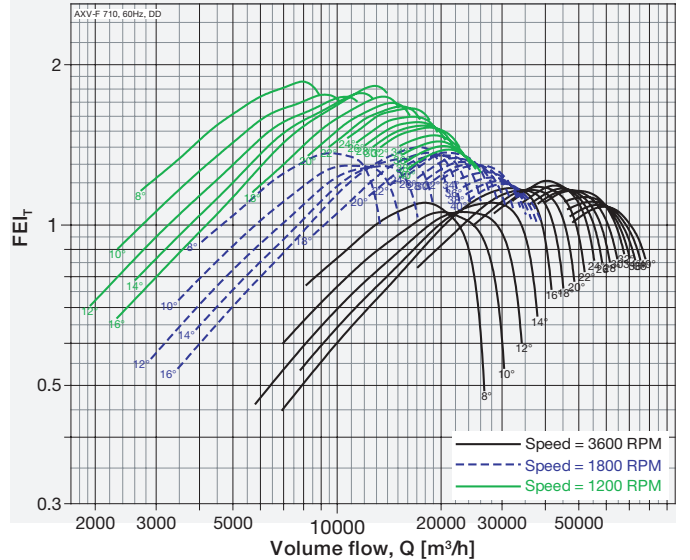

Model: AXV-F 800-238-6

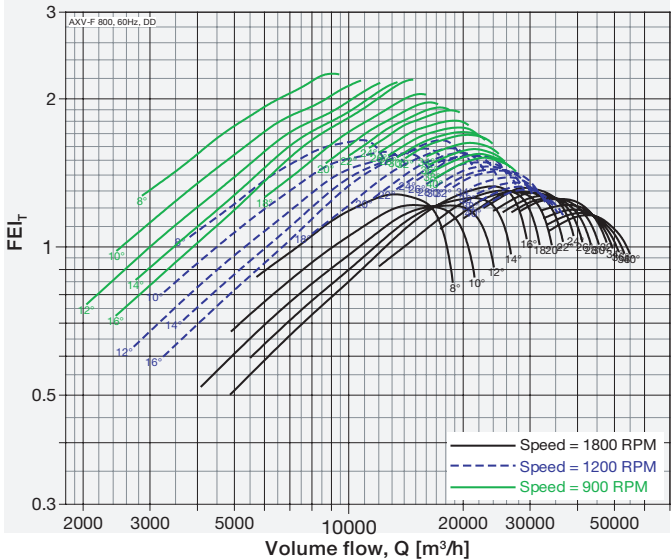

Model: AXV-F 900-267-6

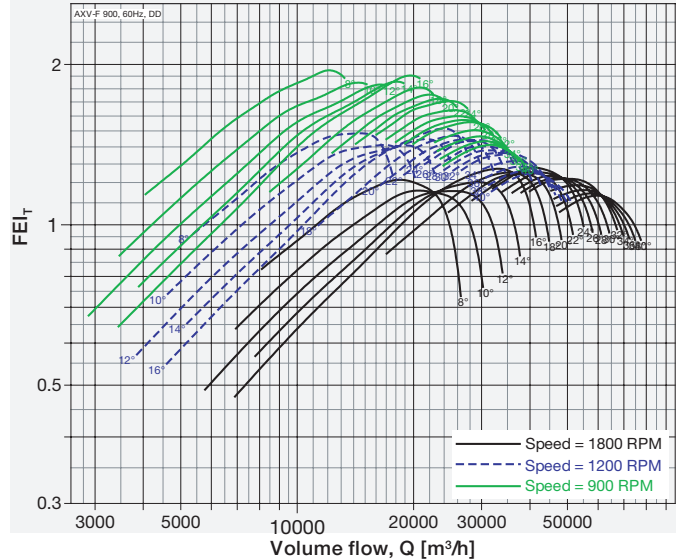

Performance of size 500 to 1250 certified is for installation type D - Ducted inlet, Ducted outlet, Performance of size 1400 to 2800 certified is for installation type A - Free inlet, Free outlet with partition. Power rating (kW) does not include transmission losses. Performance ratings do not include the effects of appurtenances (accessories-belt cover, pulley & belt). FEI₁ / FEI₂ values are calculated in accordance with ANSI/AMCA Standard 208 and are based on default motor efficiencies (Direct Driven type). FEI₁ / FEI₂ values for fans with specific motors will vary slightly from those shown.



Model: AXV-F 1000-420-6

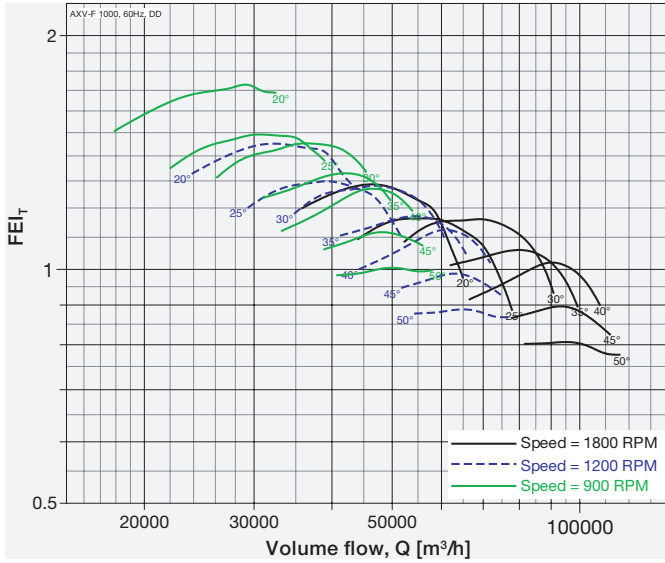

Model: AXV-F 1120-472-6

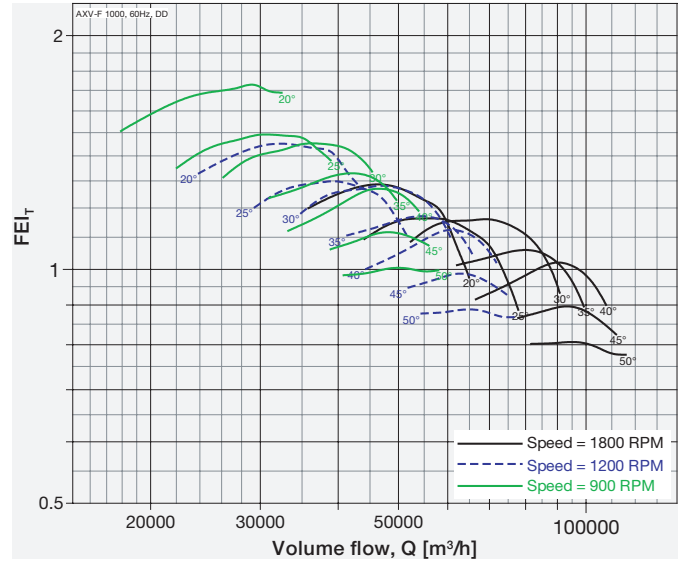

Model: AXV-F 1250-525-6

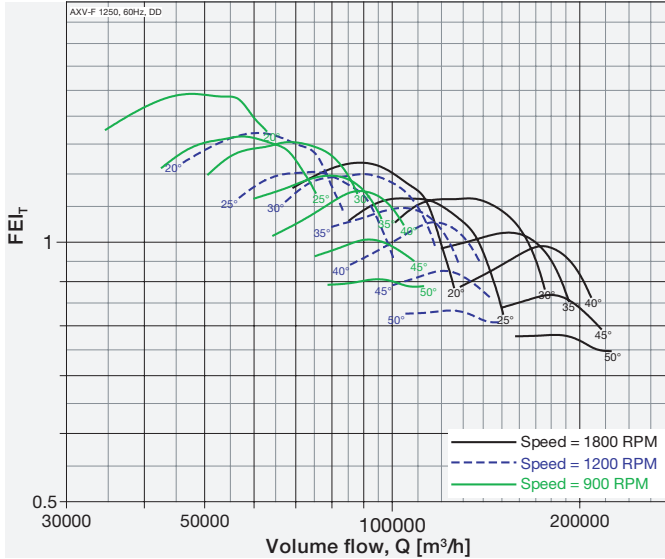

Model: AXV-F 1400-550-7

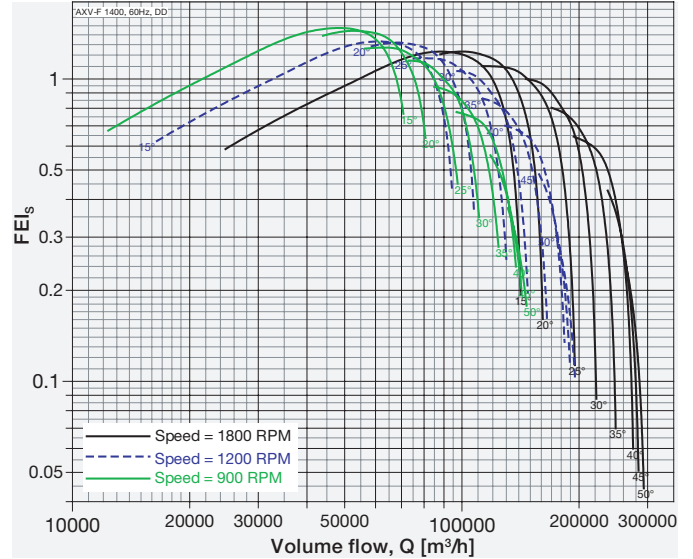

Model: AXV-F 1600-625-7

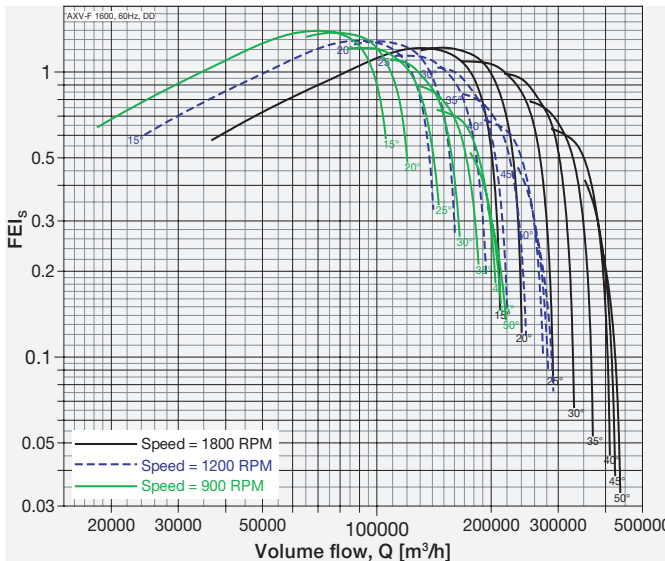

Model: AXV-F 1800-710-7

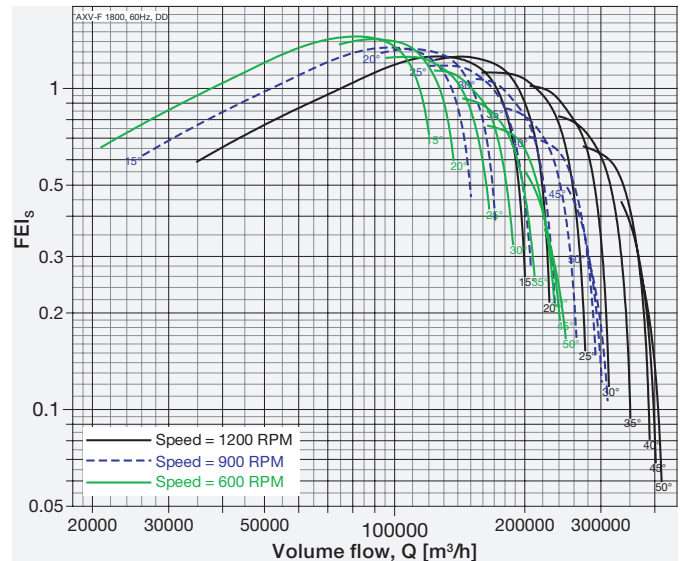

Performance of size 500 to 1250 certified is for installation type D - Ducted inlet, Ducted outlet, Performance of size 1400 to 2800 certified is for installation type A - Free inlet, Free outlet with partition. Power rating (kW) does not include transmission losses. Performance ratings do not include the effects of appurtenances (accessories-belt cover, pulley & belt). FEI_t / FEI_s values are calculated in accordance with ANSI/AMCA Standard 208 and are based on default motor efficiencies (Direct Driven type). FEI_t / FEI_s values for fans with specific motors will vary slightly from those shown.



Model: AXV-F 2000-780-7

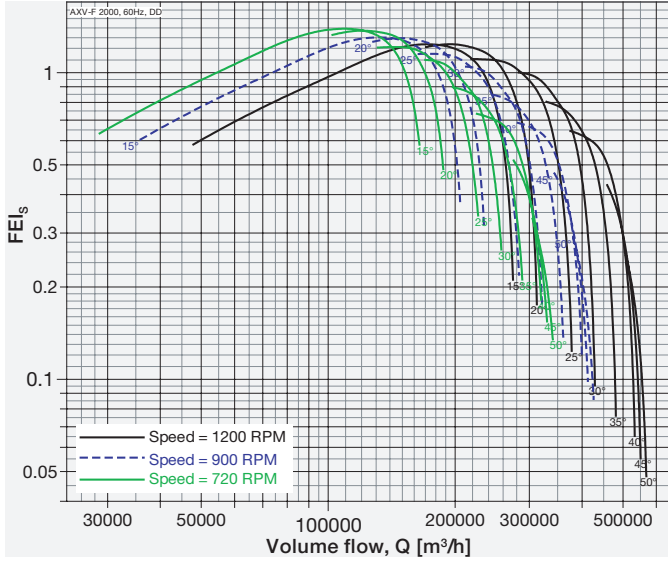

Model: AXV-F 2200-862-7

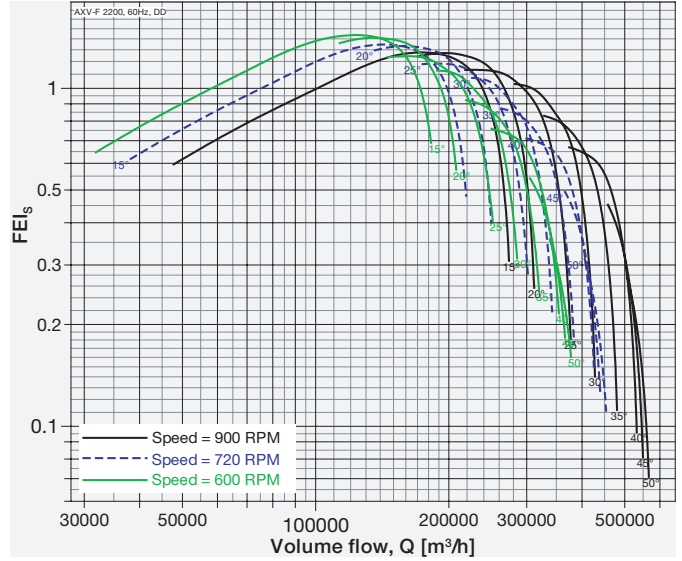

Model: AXV-F 2400-942-7

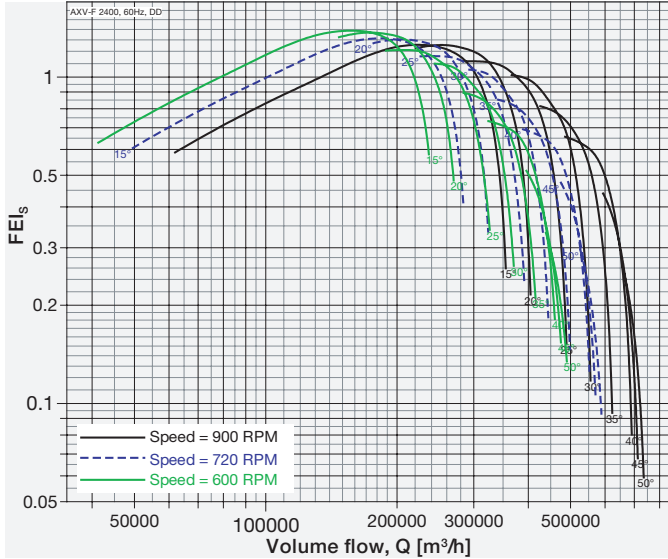

Model: AXV-F 2500-980-7

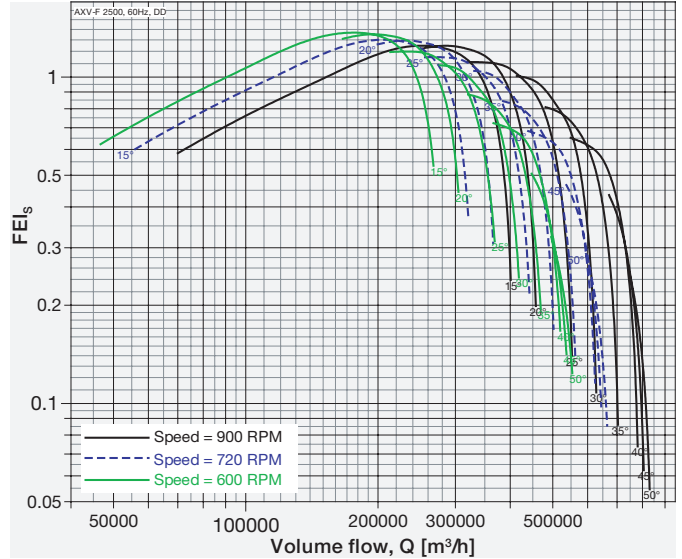

Model: AXV-F 2600-1020-7

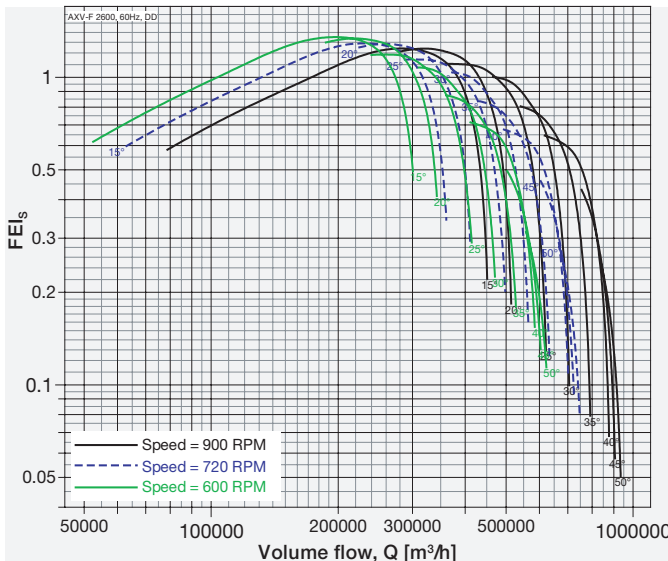

Model: AXV-F 2800-1095-7

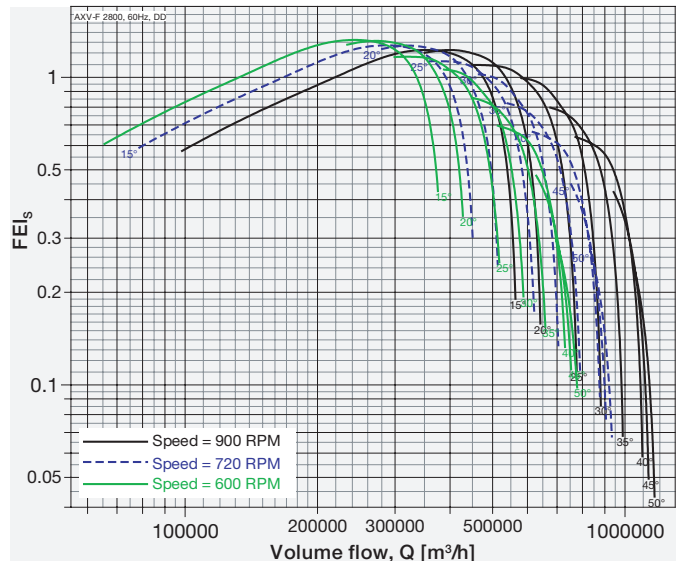

Performance of size 500 to 1250 certified is for installation type D - Ducted inlet, Ducted outlet, Performance of size 1400 to 2800 certified is for installation type A - Free inlet, Free outlet with partition. Power rating (kW) does not include transmission losses. Performance ratings do not include the effects of appurtenances (accessories-belt cover, pulley & belt). FEI_r / FEI_s values are calculated in accordance with ANSI/AMCA Standard 208 and are based on default motor efficiencies (Direct Driven type). FEI_r / FEI_s values for fans with specific motors will vary slightly from those shown.



Belt Driven Models, Size from 500 to 2800, 60Hz

Model: AXV-F 500-150-6

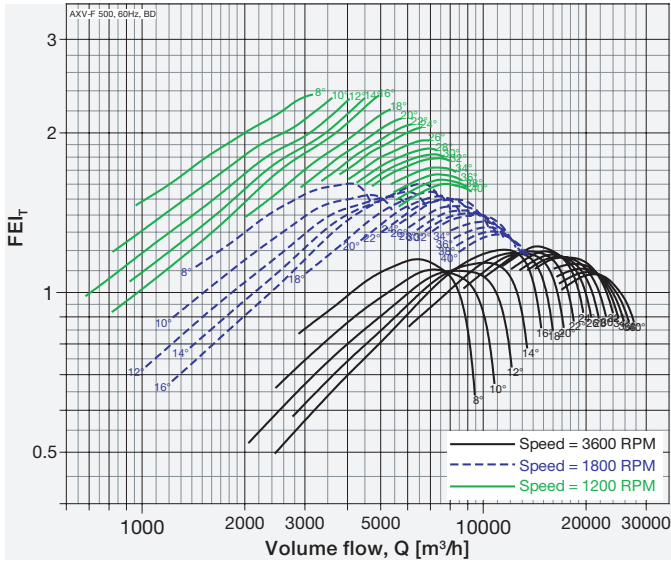

Model: AXV-F 560-168-6

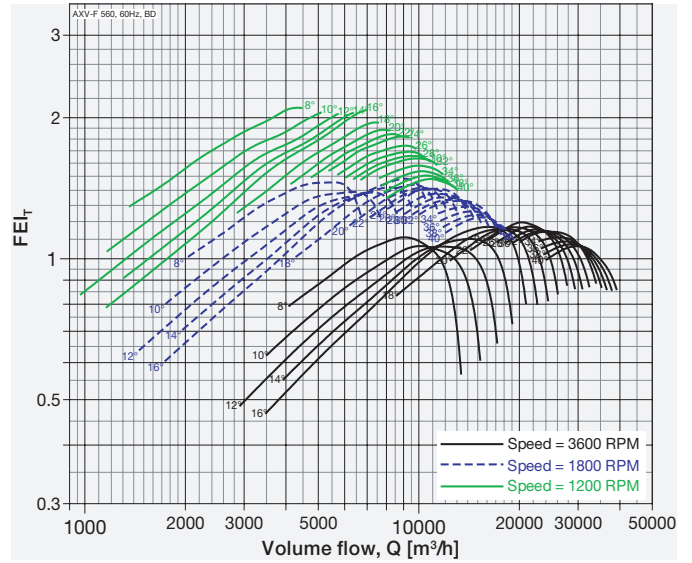

Model: AXV-F 630-200-6

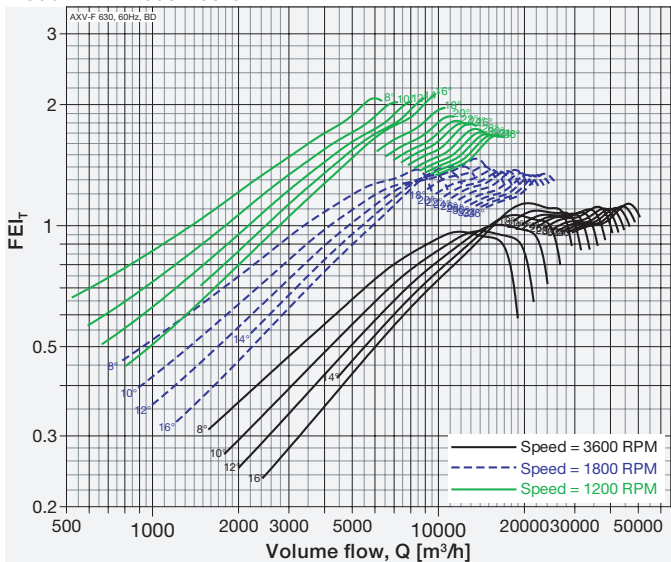

Model: AXV-F 710-212-6

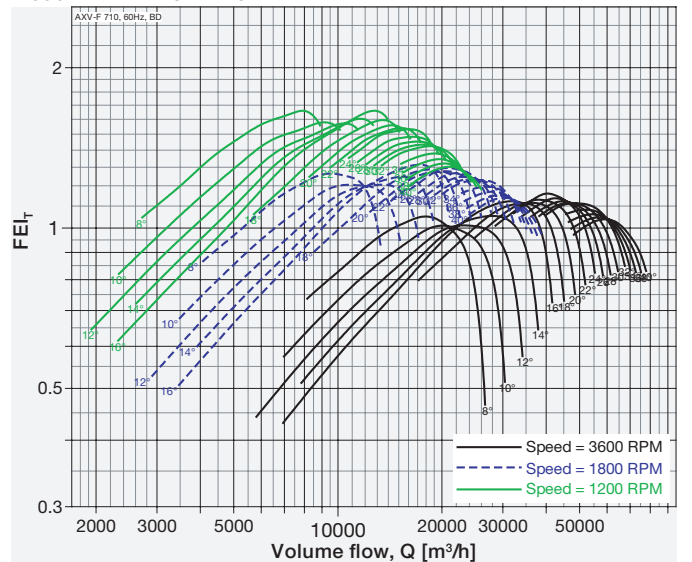

Model: AXV-F 800-238-6

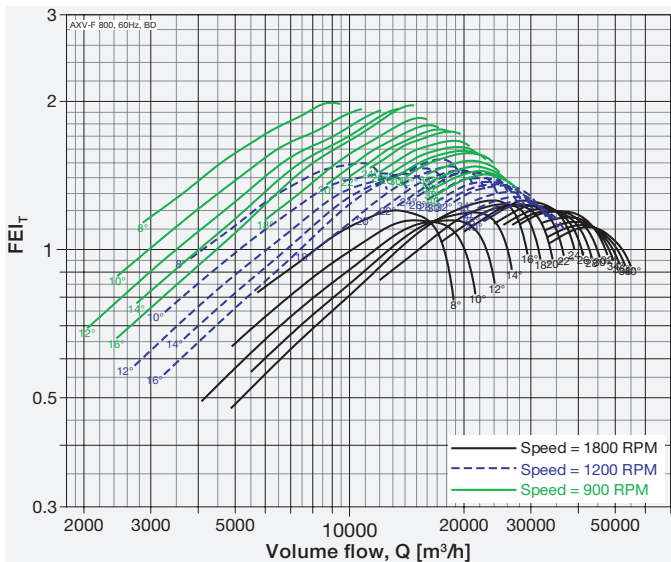

Model: AXV-F 900-267-6

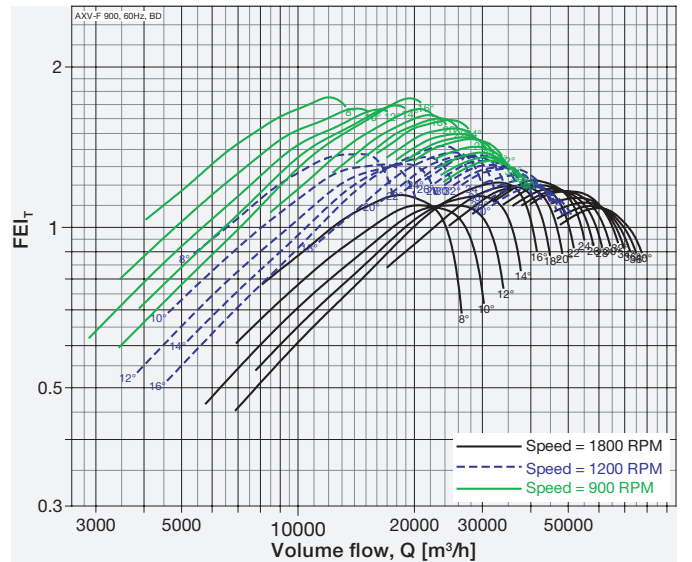

Performance of size 500 to 1250 certified is for installation type D - Ducted inlet, Ducted outlet, Performance of size 1400 to 2800 certified is for installation type A - Free inlet, Free outlet with partition. Power rating (kW) does not include transmission losses. Performance ratings do not include the effects of aperturancs (accessories-belt cover, pulley & belt). FEI_T / FEI_S values are calculated in accordance with ANSI/AMCA Standard 208 and are based on default motor efficiencies (Belt Driven type). FEI_T / FEI_S values for fans with specific motors will vary slightly from those shown.



Model: AXV-F 1000-420-6

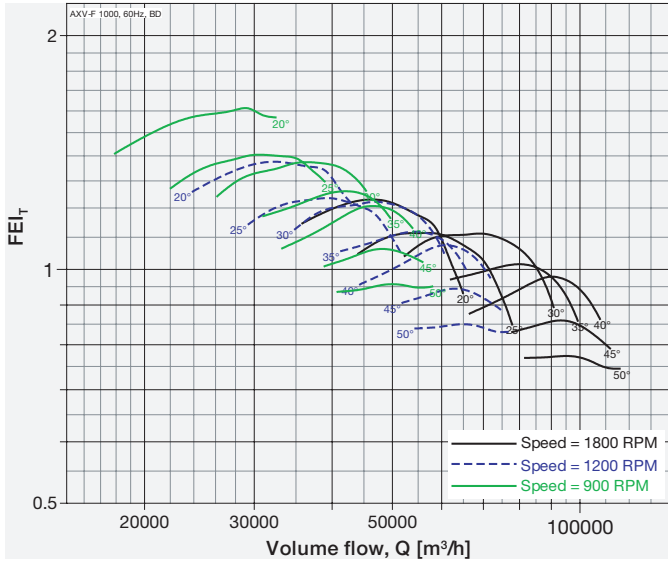

Model: AXV-F 1120-472-6

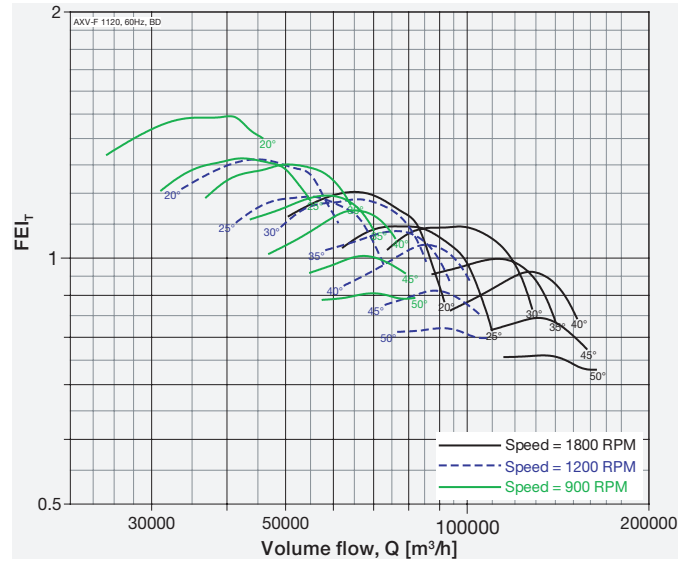

Model: AXV-F 1250-525-6

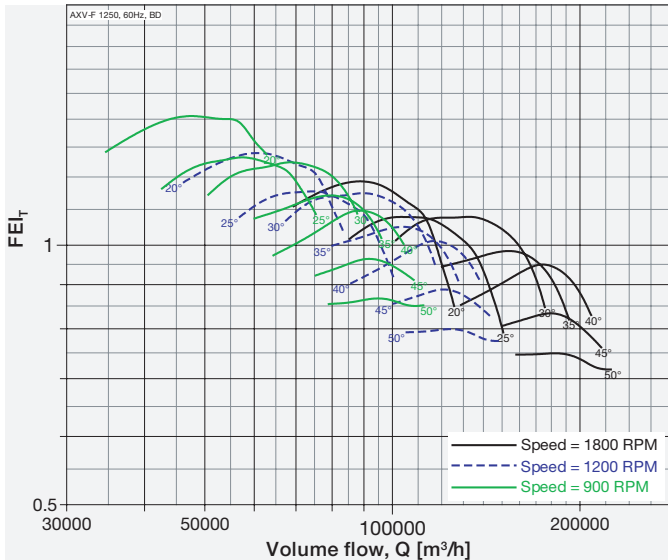

Model: AXV-F 1400-550-7

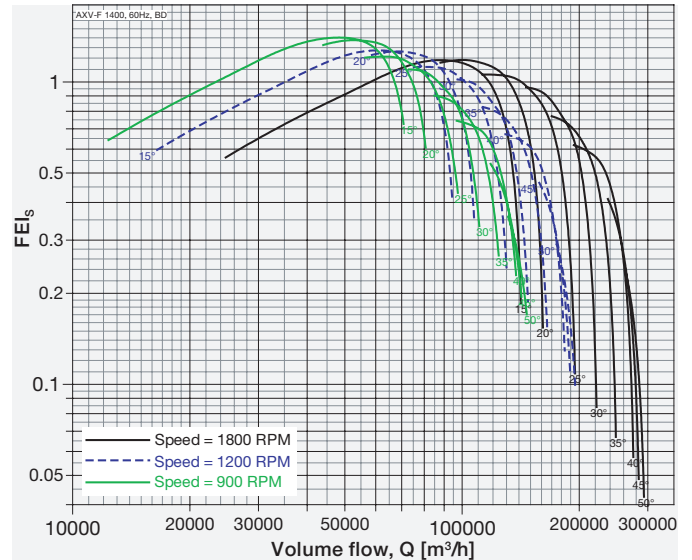

Model: AXV-F 1600-625-7

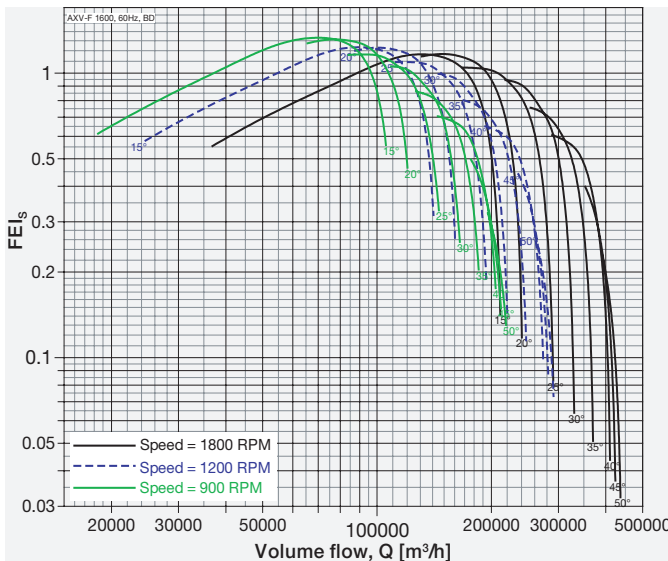

Model: AXV-F 1800-710-7

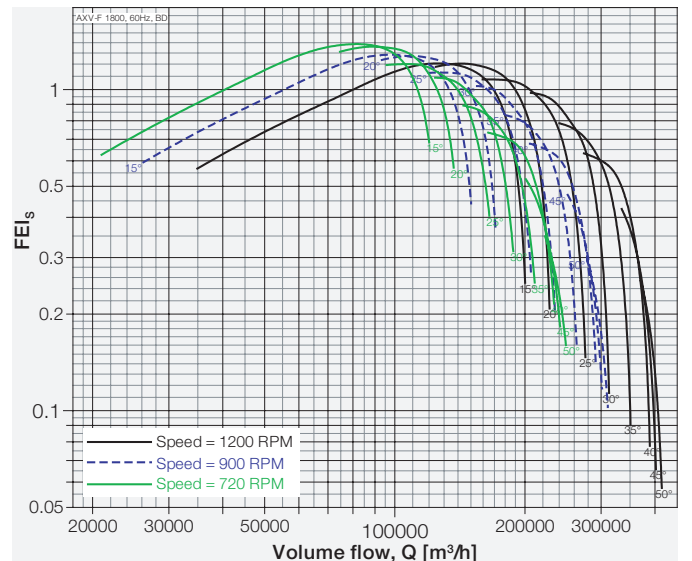

Performance of size 500 to 1250 certified is for installation type D - Ducted inlet, Ducted outlet, Performance of size 1400 to 2800 certified is for installation type A - Free inlet, Free outlet with partition. Power rating (kW) does not include transmission losses. Performance ratings do not include the effects of appurtenances (accessories-belt cover, pulley & belt). FEI_T / FEI_S values are calculated in accordance with ANSI/AMCA Standard 208 and are based on default motor efficiencies (Belt Driven type). FEI_T / FEI_S values for fans with specific motors will vary slightly from those shown.



Model: AXV-F 2000-780-7

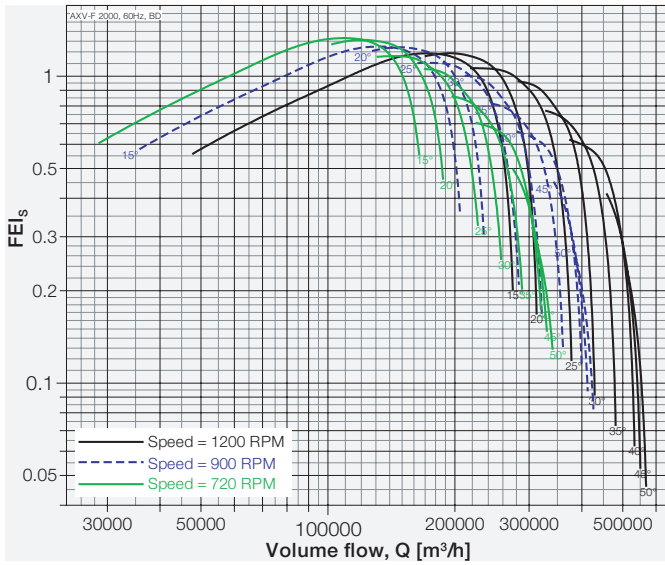

Model: AXV-F 2200-862-7

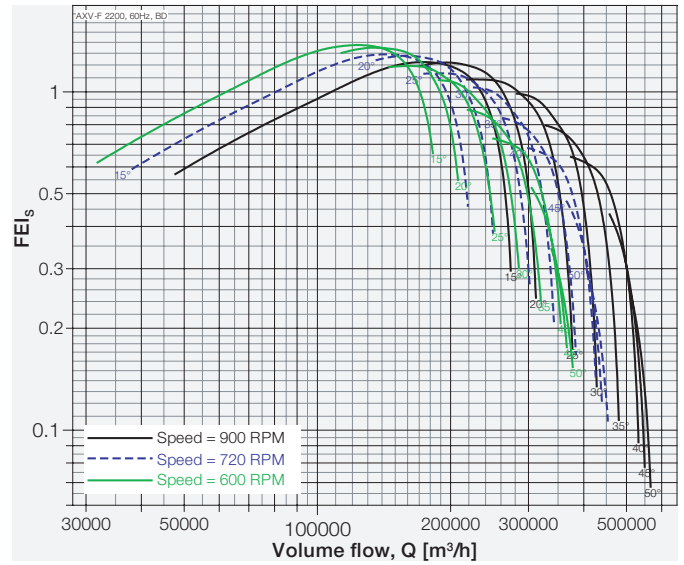

Model: AXV-F 2400-942-7

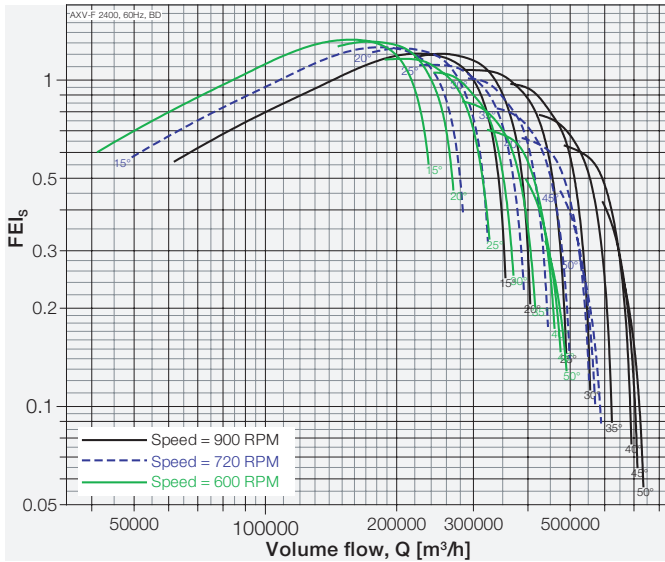

Model: AXV-F 2500-980-7

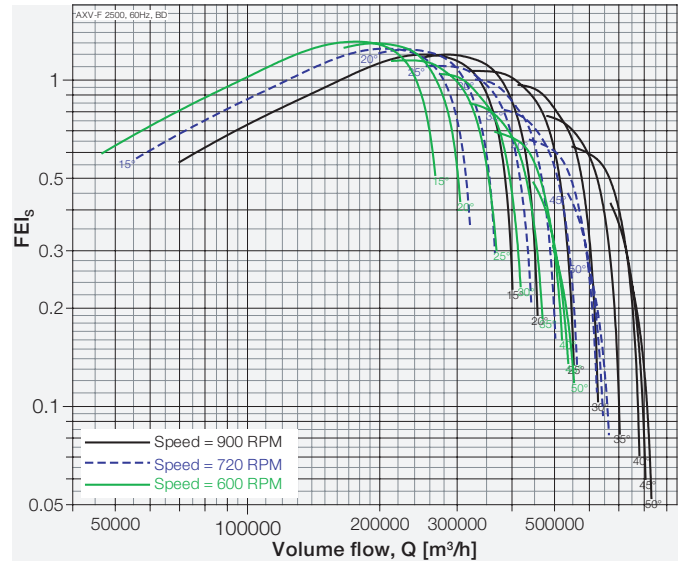

Model: AXV-F 2600-1020-7

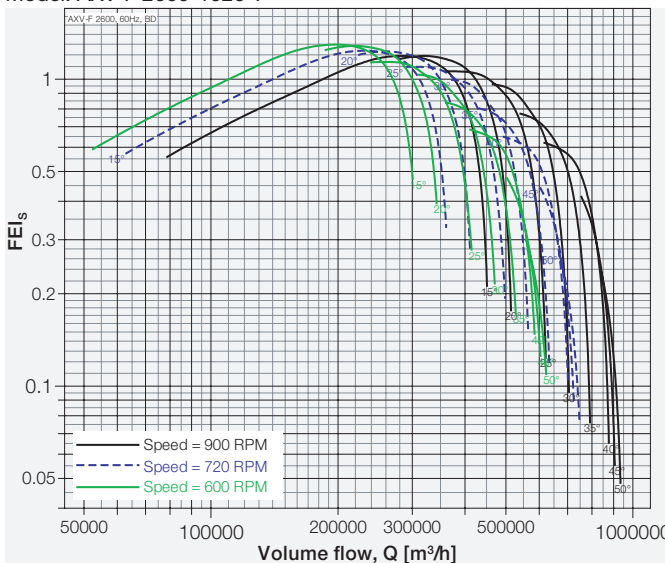

Model: AXV-F 2800-1095-7

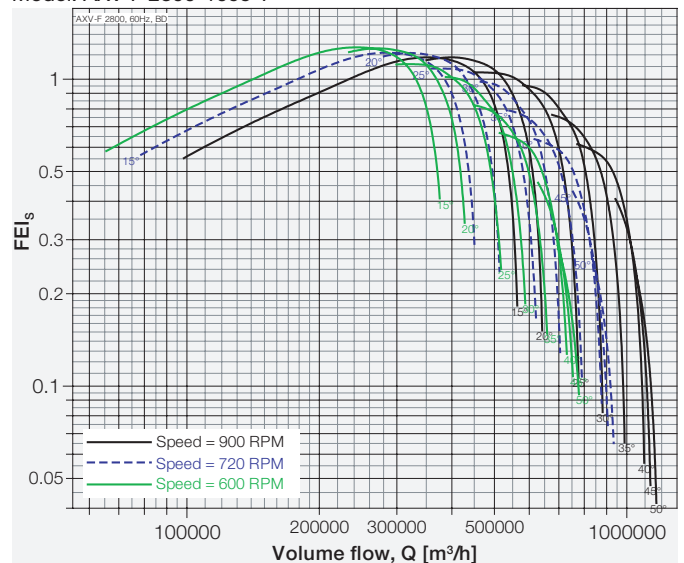

Performance of size 500 to 1250 certified is for installation type D - Ducted inlet, Ducted outlet, Performance of size 1400 to 2800 certified is for installation type A - Free inlet, Free outlet with partition. Power rating (kW) does not include transmission losses. Performance ratings do not include the effects of aperturancs (accessories-belt cover, pulley & belt). FEI_r / FEI_s values are calculated in accordance with ANSI/AMCA Standard 208 and are based on default motor efficiencies (Belt Driven type). FEI_r / FEI_s values for fans with specific motors will vary slightly from those shown.

Vane Axial Flow Fans

Dimensions

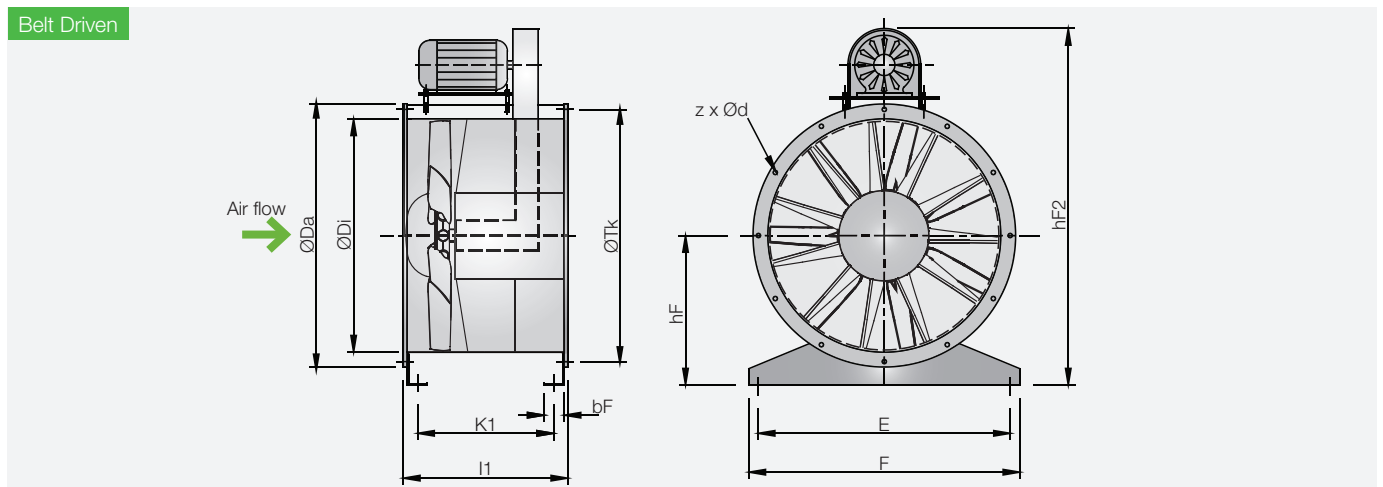
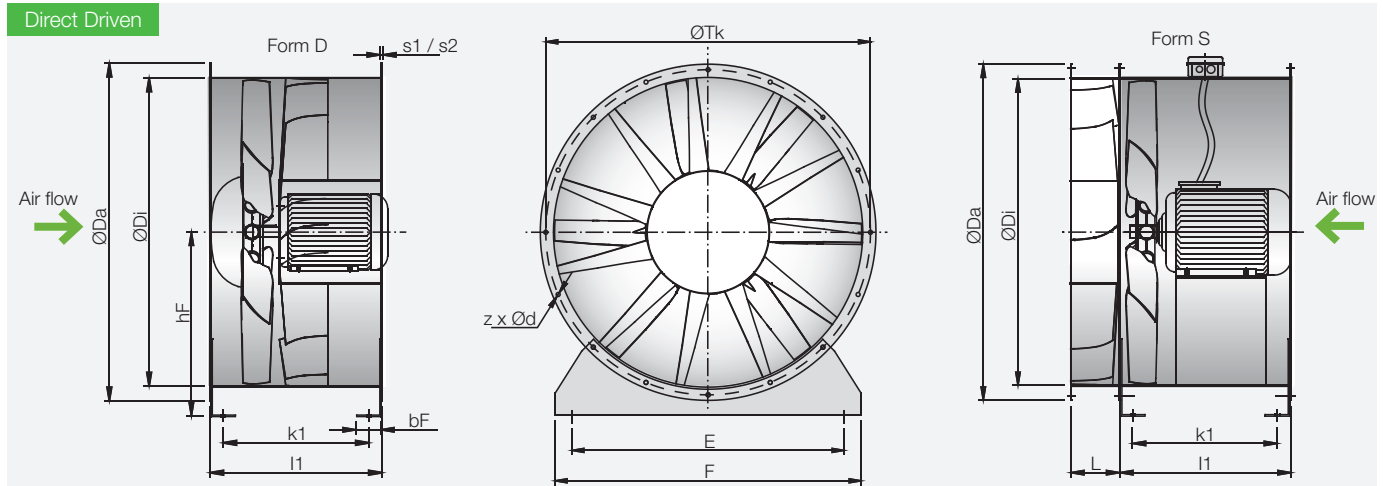

Model size	Da [mm]	Di [mm]	hF [mm]	hF2 [mm]	z x d [mm]	Tk [mm]	E [mm]	F [mm]	L [mm]	bF [mm]
500	584	504	315	910	12 x 12	551	440	500	140	70
560	664	565	345	998	16 x 14	629	500	560	150	70
630	734	634	400	1156	16 x 14	698	570	630	160	70
710	814	711	450	1300	16 x 14	775	650	710	180	70
800	904	797	500	1445	12* x 14	861	730	800	200	80
900	1004	894	580	1676	12* x 14	958	830	900	210	80
1000	1105	1003	630	1821	12* x 14	1067	930	990	280	80
1120	1245	1125	690	1990	16* x 18	1200	1050	1110	300	100
1250	1370	1250	750	2175	16* x 18	1337	1180	1240	330	100
1400	1525	1405	830	2362	16* x 18	1475	1330	1390	370	100
1600	1725	1605	930	2550	20* x 18	1675	1530	1590	420	100

LH/1 size	k1 [mm]	l1 [mm]	s1 [mm]	motor max.	s2 [mm]	motor max.	LH/2 size	k1 [mm]	l1 [mm]	s1 [mm]	motor max.	s2 [mm]	motor max.
500	326	400	2	132	2	112	560	624	700	3	160	-	-
560	326	400	2	132	2	112	630	624	700	3	160	-	-
630	326	400	2	160	2	132	710	490	565	2,5	180	-	-
710	326	400	2,5	160	2	132	800	614	700	3	180	-	-
800	326	400	2,5	160	2	132	900	612	700	4	180	3	160
900	444	530	3	225	2	200	1000	692	780	4	250	3	225
1000	444	530	3	225	2	200	1120	892	1000	4	250	3	225
1120	522	630	4	225	3	200	1250	892	1000	4	280	3	250
1250	522	630	4	250	3	225	1400	892	1000	4	315	3	280
							1600	892	1000	4	315	3	280

* Form S direction is not licensed by AMCA International.
We reserve the right to alter measurements without notice in case of technical improvements.

Vane Axial Flow Fans



Dimensions

Bifurcated

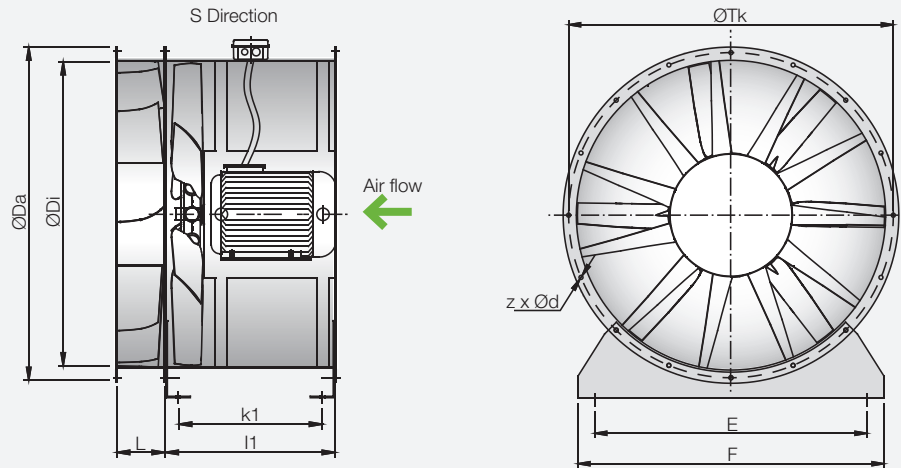

Model size	Da [mm]	Di [mm]	z x d [mm]	Tk [mm]	E [mm]	F [mm]	L [mm]
500	584	504	12 x 12	551	440	500	140
560	664	565	16 x 14	629	500	560	150
630	734	634	16 x 14	698	570	630	160
710	814	711	16 x 14	775	650	710	180
800	904	797	12* x 14	861	730	800	200
900	1004	894	12* x 14	958	830	900	210
1000	1105	1003	12* x 14	1067	930	990	280
1120	1245	1125	16* x 18	1200	1050	1110	300
1250	1370	1250	16* x 18	1337	1180	1240	330
1400	1525	1405	16* x 18	1475	1330	1390	370
1600	1725	1605	20* x 18	1675	1530	1590	420

LH/1 size	k1 [mm]	l1 [mm]	s1 [mm]	motor max.	s2 [mm]	motor max.	LH/2 size	k1 [mm]	l1 [mm]	s1 [mm]	motor max.	s2 [mm]	motor max.
500	326	400	2	132	2	112	560	624	700	3	160	-	-
560	326	400	2	132	2	112	630	624	700	3	160	-	-
630	326	400	2	160	2	132	710	490	565	2,5	180	-	-
710	326	400	2,5	160	2	132	800	614	700	3	180	-	-
800	326	400	2,5	160	2	132	900	612	700	4	180	3	160
900	444	530	3	225	2	200	1000	692	780	4	250	3	225
1000	444	530	3	225	2	200	1120	892	1000	4	250	3	225
1120	522	630	4	225	3	200	1250	892	1000	4	280	3	250
1250	522	630	4	250	3	225	1400	892	1000	4	315	3	280
							1600	892	1000	4	315	3	280

The Bifurcated Vane Axial Fan are not licensed by AMCA International.

We reserve the right to alter measurements without notice in case of technical improvements.

Vane Axial Flow Fans

Dimensions

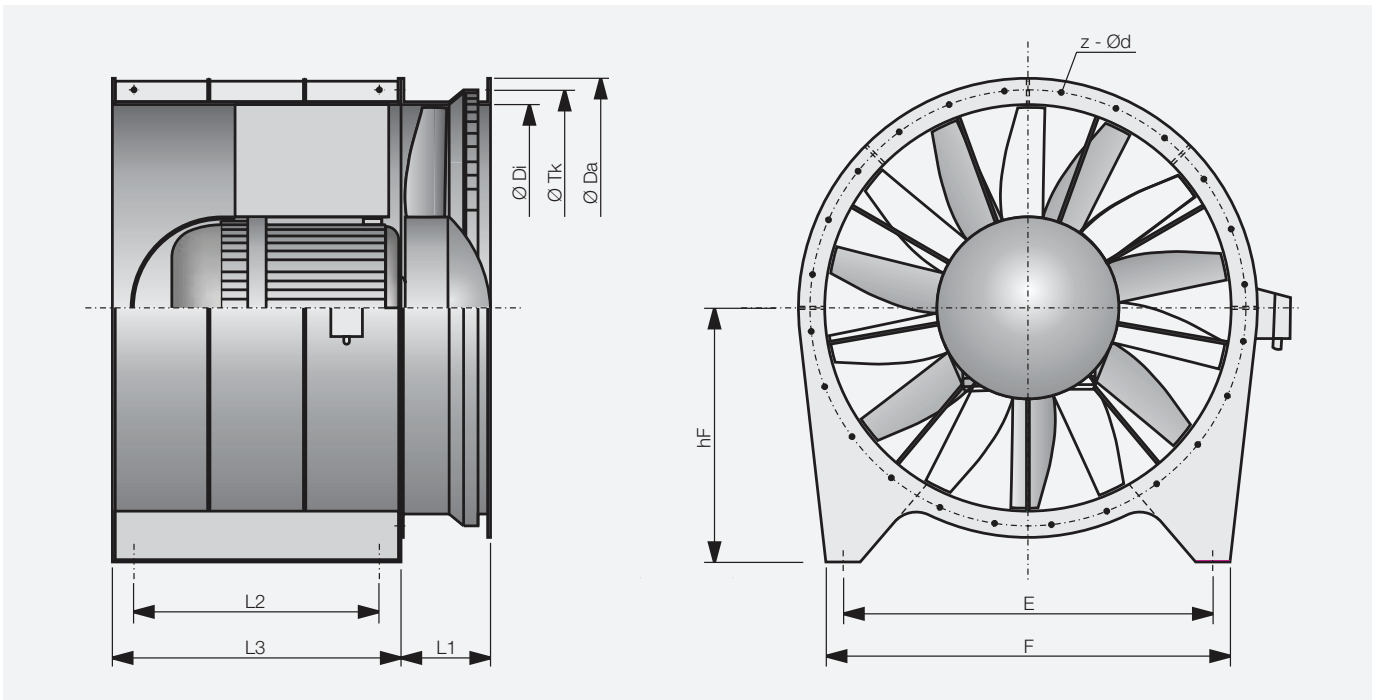

Model size	Da [mm]	Di [mm]	hF [mm]	z x d [mm]	Tk [mm]	E [mm]	F [mm]	L1 [mm]	L2 [mm]	L3 [mm]
1800	2010	1805	1120	24x18	1920	1660	1800	400	1200	1400
2000	2210	2005	1165	32x18	2120	1820	2000	445	1300	1500
2200	2440	2205	1265	32x18	2340	2020	2200	490	1400	1650
2400	2630	2405	1370	32x18	2530	2220	2400	550	1500	1800
2500	2740	2505	1420	36x24	2640	2320	2500	555	1530	1820
2600	2840	2605	1470	36x24	2740	2380	2600	590	1580	1850
2800	3150	2805	1570	36x24	3000	2500	2800	1300	1680	1900

Vane Axial Flow Fans

Accessories



ED

Bellmouth inlet

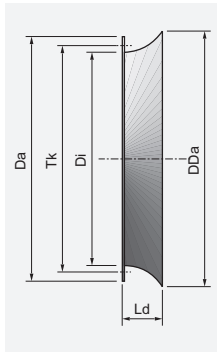

GL-AXV

Matching flange

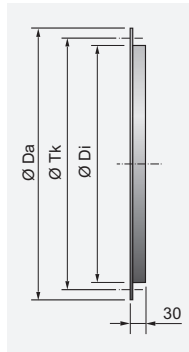

EV-AXV

Flexible connector

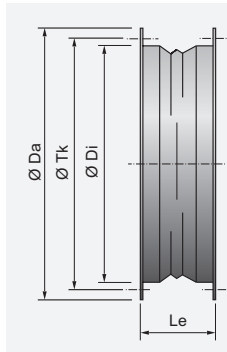

LRK

Air-operated damper

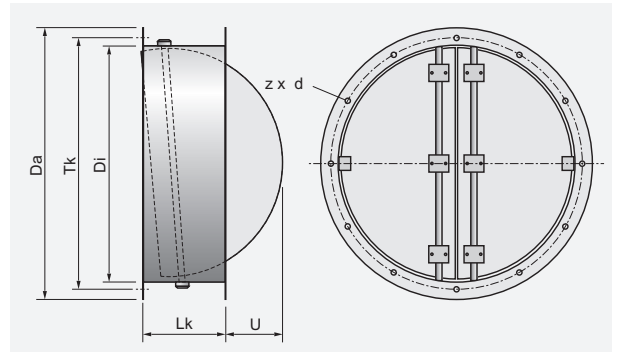

Model size	Da [mm]	Di [mm]	Tk [mm]	z x d [mm]	DDa [mm]	Ld [mm]	Lk [mm]	Le [mm]	U [mm]
500	584	504	551	12 x 12	617	165	250	130	45
560	664	565	629	16 x 14	667	165	250	130	80
630	734	634	698	16 x 14	757	165	250	130	120
710	814	711	775	16 x 14	816	170	350	130	60
800	904	797	861	12* x 14	915	250	350	130	110
900	1004	894	958	12* x 14	1015	250	350	130	170
1000	1105	1003	1067	12* x 14	1115	250	350	130	225
1120	1245	1125	1200	16* x 18	1243	250	350	130	255
1250	1370	1250	1337	16* x 18	1364	250	400	170	375
1400	1525	1405	1475	16* x 18	1523	250	400	170	450
1600	1725	1605	1675	20* x 18	1723	250	400	170	550

Sound power levels

This term refers to the power which a source radiates as sound. Sound power levels are expressed in decibels with a reference level of 1 picoWatt. The sound power level of a source remains the same regardless of its environment and the distance to the listener.

If the sound power frequency spectrum is needed, for as follows: example, the design of sound attenuators, the A-weighted rated sound power levels at particular octave band frequency L_{WA} can be calculated by subtracting the relative sound L_{wrel} .

$$L_{WA} = L_{wi} + L_{wrel}$$

Sound pressure level

These are pressure fluctuations generated by a source expressed in decibels with a reference level of 20 μ Pa. The sound pressure level varies with the distance of a sound source to the listener and its environment.

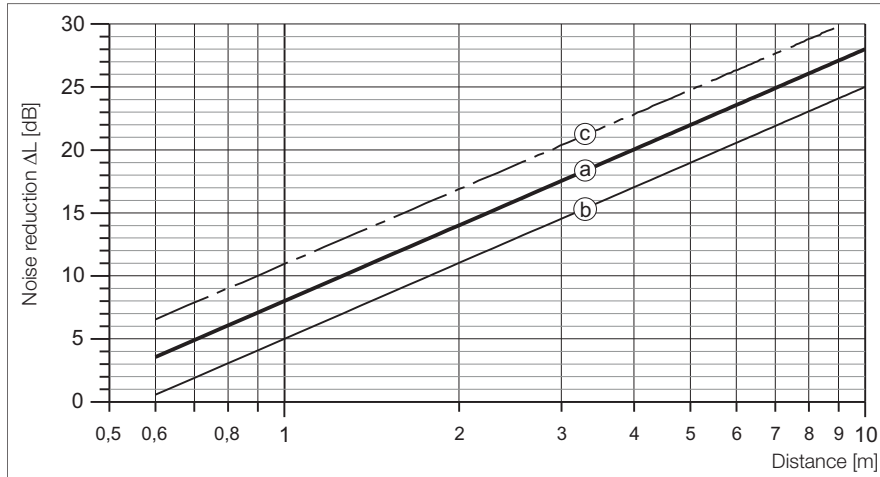

Sound level reduction half sphere

- a: without reflexion
- b: with reflexion
- c: full sphere without reflexion

Frequencies

Sound is split into different frequencies. Frequencies of human hearing range from about 20 cycles per second (Hz) to 20.000 cycles per second (Hz). For practical purposes, Wolter publishes noise data in eight octave bands with the centre frequencies of (63,) 125, 250, 500, 1000, 2000, 4000 and 8000 Hz.

Each fan has its own specific correction factor which is to be deducted from sound power according to the octave band.

A-weighted sound pressure level in dB (A)

The human ear is more sensitive to sound in some frequencies than in others. The A-weighting is an attempt to reflect this natural perception of sound. The A-weighting is a set of figures which are applied to the sound pressure levels. The levels in each of the octave bands are added logarithmically to give a single figure. The A-weighting over the octave band is as follows:

Table 1)

Frequency [Hz]	63	125	250	500	1000	2000	4000	8000
A-weighting [dB]	-26,2	-16,1	-8,6	-3,2	0	+1,2	+1,0	-1,1

Table 2)

Addition of sound levels

Difference between two sound levels [dB]	Add to the higher level [dB]
0 - 1	3
2 - 3	2
4 - 9	1
≥ 10	0

$$L_{\Sigma} = 10 \cdot \lg(10^{0,1 \cdot L_1} + 10^{0,1 \cdot L_2} + \dots + 10^{0,1 \cdot L_n})$$

where:

- L_1 = sound level of a source 1
- L_{Σ} = resulting summation sound level

Summation of several congeneric sound levels

$$L_{\Sigma} = L_1 + 10 \cdot \lg(z)$$

where:

- z = number of sources
- L_1 = sound level of a single source
- L_{Σ} = resulting summation sound level

Relative Sound Power Frequency Spectrum (L_{wrel}) [Δ dB]

Fan Model	Poles	63	125	250	500	1000	2000	4000	8000
Size	[-]	[Hz]	[Hz]	[Hz]	[Hz]	[Hz]	[Hz]	[Hz]	[Hz]
500	2	-11	-8	-10	-7	-8	-12	-16	-21
	4	-8	-10	-6	-8	-11	-16	-21	-26
	6	-8	-8	-5	-10	-13	-18	-23	-28
560	2	-11	-8	-10	-7	-8	-12	-16	-21
	4	-8	-10	-6	-8	-11	-16	-21	-26
	6	-8	-8	-5	-10	-13	-18	-23	-28
630	2	-11	-8	-10	-7	-8	-12	-16	-21
	4	-8	-10	-6	-8	-11	-16	-21	-26
	6	-8	-8	-5	-10	-13	-18	-23	-28
710	2	-11	-8	-10	-7	-8	-12	-16	-21
	4	-8	-10	-6	-8	-11	-16	-21	-26
	6	-8	-8	-5	-10	-13	-18	-23	-28
800	4	-8	-10	-6	-8	-11	-16	-21	-26
	6	-8	-8	-5	-10	-13	-18	-23	-28
	8	-9	-5	-6	-10	-15	-19	-24	-30
900	4	-7	-10	-6	-8	-11	-16	-21	-26
	6	-8	-8	-5	-10	-13	-18	-23	-28
	8	-9	-5	-6	-10	-15	-19	-24	-30
1000	4	-10	-5	-6	-8	-14	-18	-24	-29
	6	-7	-6	-5	-10	-15	-20	-26	-31
	8	-7	-5	-6	-11	-15	-21	-27	-32
1120	4	-10	-5	-6	-8	-14	-18	-24	-29
	6	-7	-6	-5	-11	-15	-20	-26	-31
	8	-6	-5	-6	-11	-16	-22	-27	-32
1250	4	-9	-5	-6	-8	-14	-18	-24	-30
	6	-6	-6	-6	-11	-15	-21	-26	-31
	8	-6	-5	-6	-12	-16	-22	-27	-32
1400	4	-9	-5	-4	-5	-7	-9	-12	-15
	6	-11	-6	-5	-6	-9	-13	-16	-20
	8	-11	-6	-6	-9	-13	-18	-22	-26
1600	4	-9	-5	-4	-5	-7	-9	-12	-15
	6	-11	-6	-6	-6	-9	-13	-16	-20
	8	-10	-6	-7	-9	-13	-18	-22	-26

• Sound power frequency spectrum calculated with this L_{wrel} are not licensed by AMCA International.

Relative Sound Power Frequency Spectrum (L_{wrel}) [Δ dB]

Fan Model	Poles	63	125	250	500	1000	2000	4000	8000
Size	[-]	[Hz]	[Hz]	[Hz]	[Hz]	[Hz]	[Hz]	[Hz]	[Hz]
1800	6	-7	-4	-4	-6	-8	-11	-13	-17
	8	-9	-5	-5	-7	-10	-14	-18	-22
	10	-8	-6	-7	-10	-15	-19	-23	-27
2000	6	-7	-4	-4	-6	-8	-11	-13	-17
	8	-8	-5	-5	-7	-10	-14	-18	-22
	10	-8	-6	-7	-10	-15	-19	-23	-27
2200	8	-6	-3	-4	-6	-9	-11	-14	-18
	10	-7	-5	-5	-8	-12	-15	-19	-23
	12	-7	-6	-7	-11	-16	-20	-24	-28
2400	8	-5	-3	-4	-6	-9	-12	-15	-18
	10	-7	-5	-5	-8	-12	-15	-19	-23
	12	-6	-6	-8	-11	-16	-20	-24	-28
2500	8	-5	-3	-4	-6	-9	-12	-15	-18
	10	-7	-5	-5	-8	-12	-15	-19	-23
	12	-6	-6	-8	-11	-16	-20	-24	-28
2600	8	-5	-3	-4	-7	-9	-12	-15	-18
	10	-7	-5	-5	-8	-12	-15	-19	-23
	12	-6	-6	-8	-11	-16	-20	-24	-28
2800	8	-5	-3	-4	-7	-9	-12	-15	-18
	10	-7	-5	-6	-8	-12	-15	-19	-23
	12	-6	-6	-8	-11	-16	-20	-24	-28

• Sound power frequency spectrum calculated with this L_{wrel} are not licensed by AMCA International.

Tubular Sound Attenuator

SA, SPA



SPA 1000 -1D

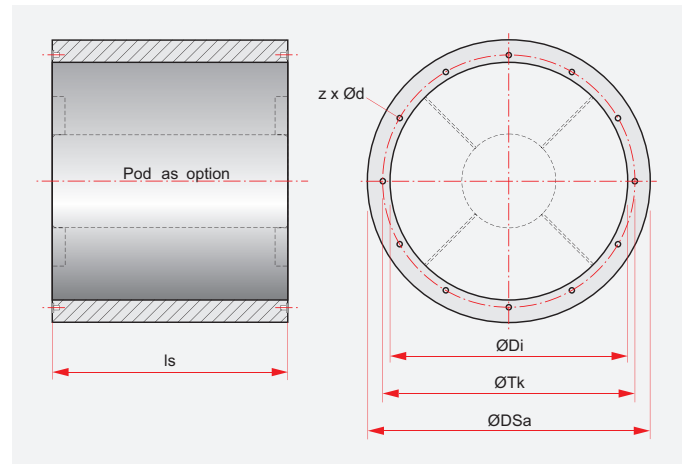
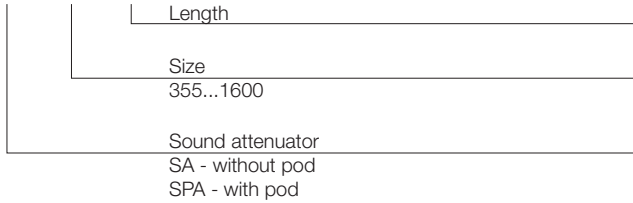

Attenuators made of galvanised sheet steel. Connecting flanges correspond to those of the axial fan series.

Size	DSa	Tk	Di	ls		Pitch angle				Length	Type	Pitch angle	Octave band mid-frequency [Hz]												
				x 1D	x 2D	SA-1D	SPA-1D	SA-2D	SPA-2D				63	125	250	500	1k	2k	4k	8k					
	[mm]	[mm]	[mm]	[mm]	[mm]	[kg]	[kg]	[kg]	[kg]			setting													
355	459	405	359	355	710	12	18	16	23	1D	SA-1D	all	2	4	6	10	14	10	7	8					
400	601	448	401	400	800	14	23	19	29		SPA-1D	low	4	6	8	13	20	21	18	16					
450	650	497	450	450	900	18	29	23	36		med	4	6	8	12	18	19	18	14						
											high	4	6	8	11	13	16	16	11						
											2D	SA-2D	low	4	7	12	18	22	17	12	13				
												med	4	7	11	17	21	17	13	12					
												high	4	7	10	15	19	16	13	10					
												SPA-2D	low	7	10	15	24	32	35	30	28				
												med	7	10	15	21	26	26	24	22					
												high	7	10	15	16	15	17	13	13					
500	704	551	504	500	1000	22	36	28	43		1D	SA-1D	all	3	4	8	14	14	9	8	7				
560	765	629	565	560	1120	25	41	31	50			SPA-1D	low	4	6	9	17	26	21	18	12				
630	834	698	634	630	1260	29	47	37	59	med		4	6	9	17	23	20	18	11						
710	911	775	711	710	1420	37	60	47	75	high		4	6	9	16	17	16	14	11						
800	997	861	797	800	1600	69	108	90	141	2D		SA-2D	low	6	8	14	23	24	15	13	10				
												med	6	8	13	22	22	14	13	9					
												high	6	8	12	20	18	13	11	9					
												SPA-2D	low	8	11	16	30	39	35	32	22				
												med	8	11	16	27	32	32	29	19					
												high	8	11	16	24	23	23	24	17					
900	1094	958	894	900	1800	86	135	112	176	1D		SA-1D	all	3	4	9	14	12	8	7	7				
1000	1203	1067	1003	1000	2000	125	190	156	234			SPA-1D	low	4	6	11	22	21	16	14	11				
1120	1325	1200	1125	1120	2240	132	210	169	260		med.	4	6	11	20	19	15	13	11						
1250	1450	1337	1250	1250	2500	146	234	185	294		high	4	6	11	17	17	14	12	11						
											2D	SA-2D	low	6	8	14	22	20	13	12	10				
												med.	6	8	13	21	18	12	11	10					
												high	6	8	12	19	15	11	10	9					
												SPA-2D	low	8	11	19	30	32	30	24	17				
												med.	8	11	19	26	27	26	22	17					
												high	8	11	19	21	20	22	20	16					
1400	1605	1475	1405	1400	2800	197	316	250	397		1D	SA-1D	all	4	5	10	14	11	7	6	6				
1600	1805	1675	1605	1600	3200	275	540	348	682			SPA-1D	low	5	7	12	21	20	14	12	9				
										med.		5	7	12	19	18	13	11	9						
										high		5	7	12	15	16	12	10	8						
										2D		SA-2D	low	8	9	15	20	19	12	11	9				
												med.	8	9	14	20	17	11	10	9					
												high	8	9	13	19	14	10	9	9					
												SPA-2D	low	10	14	22	28	31	29	18	15				
												med.	10	14	22	25	27	25	16	15					
												high	10	14	22	21	21	21	15	14					

• Low, Medium and High Pitch Angle setting correspond to 10°, 22° and 35° pitch angle approximately: for other pitch angles use interpolation.

• Sizes 1800 - 2800 TBA.

Pressure Loss SPA - 1D

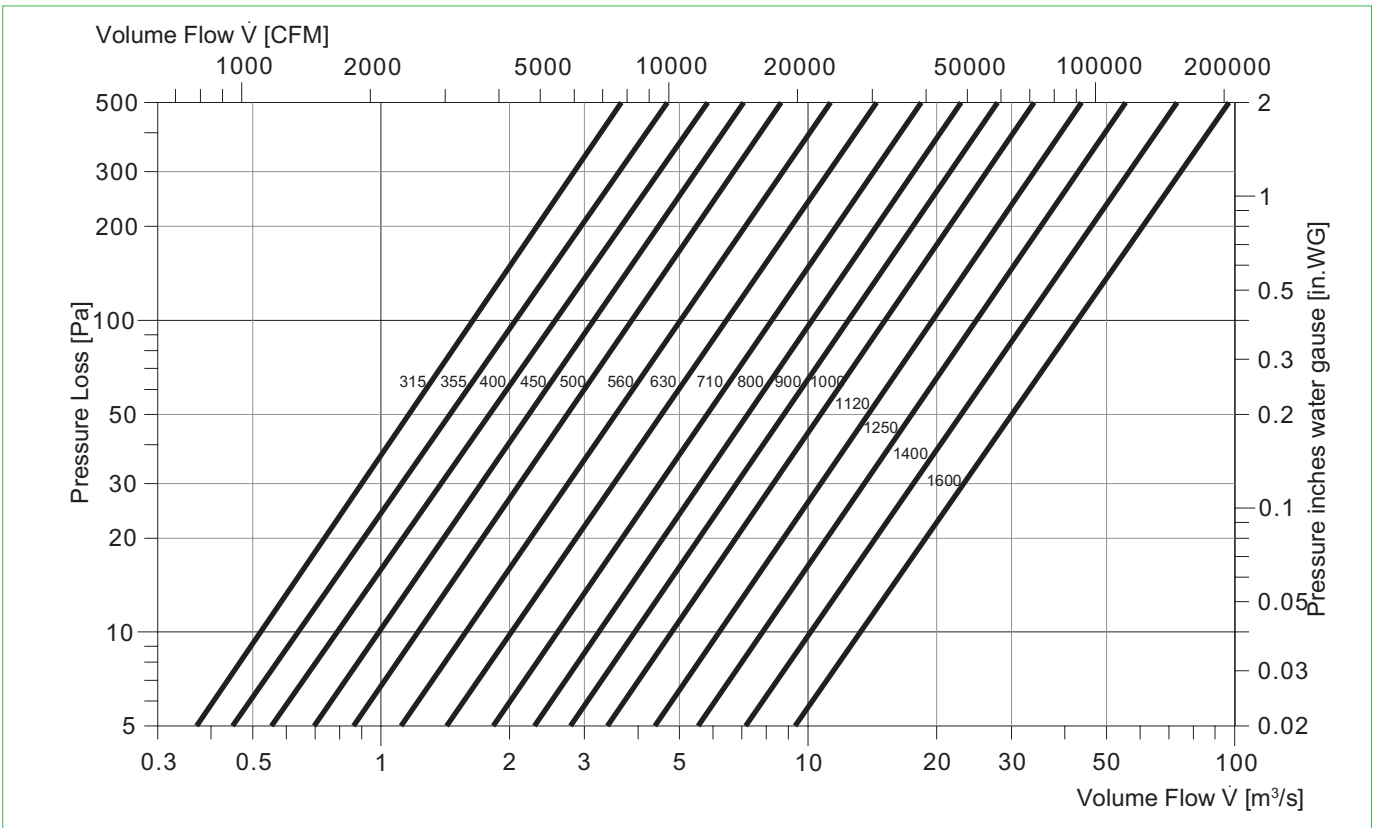

Pressure Loss SPA - 2D

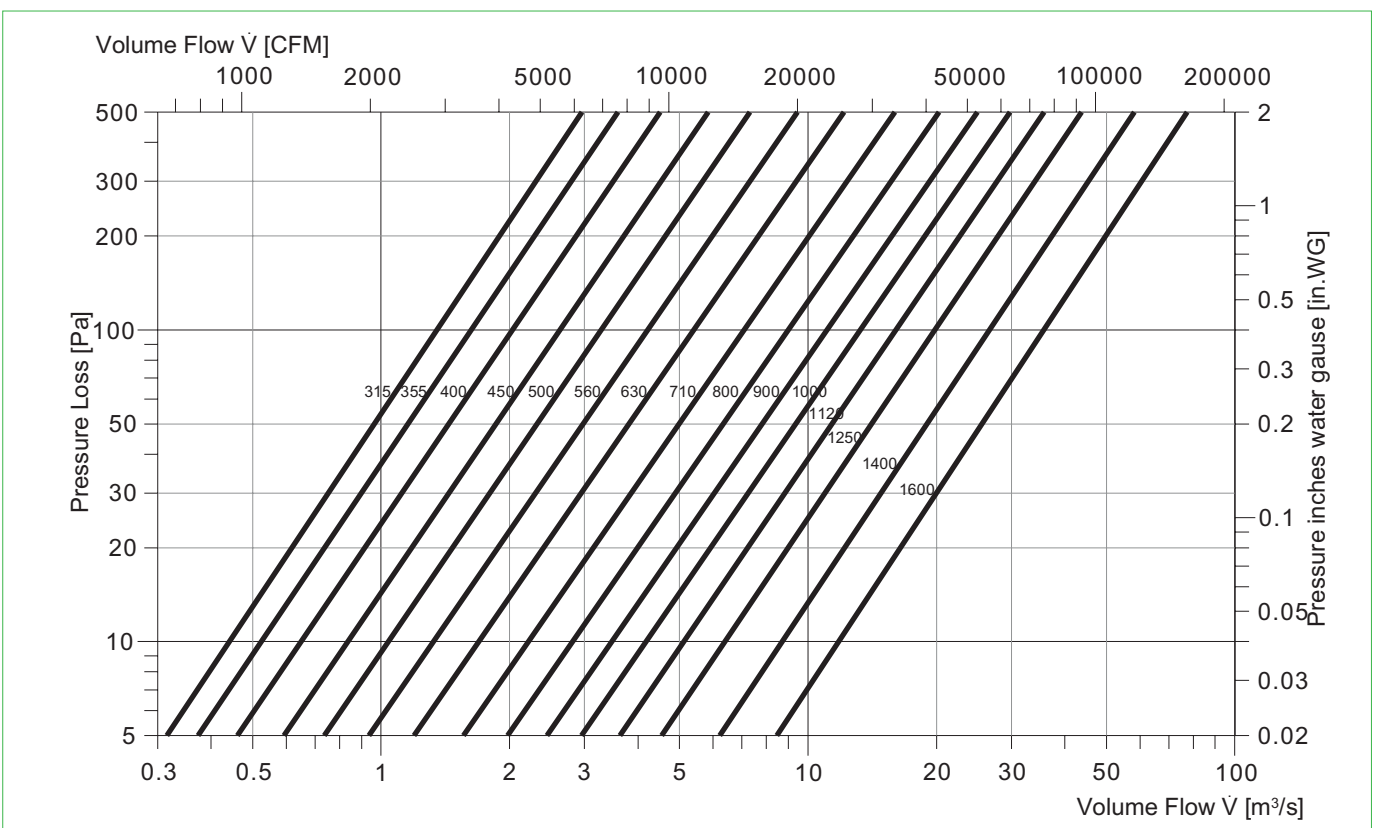

• Performance of sound attenuator are not licensed by AMCA International.

Wolter Sales Network

Inland

Ing. Günther Rößler
D-07619 Schkölen
T +49 (0) 36 69 4 / 22 359
F +49 (0) 36 69 4 / 22 357
guenther.roessler@wolter.eu

Mattias Industrievertretungen
D-16259 Bad Freienwalde
T +49 (0) 33 44 / 30 19 94
F +49 (0) 33 44 / 30 19 96
thomas.mattias@wolter.eu

Europe

Denmark:

Aircon Teknik A/S
DK-8200 Aarhus N
T +45 (0) 86 / 34 51 11
F +45 (0) 86 / 34 58 10
post@airconteknik.dk

AIRFORCE ApS
DK-8881 Thorsø
T +45 (0) 58 58 58 54
info@airforce.dk

The Netherlands:

AirFan B. V.
NL-7442 CX Nijverdal
T +31 (0) 548 / 36 63 66
F +31 (0) 548 / 36 53 20
ventilatie@airfan.nl

Russia:

Daichi Co. Ltd
RU-123022 Moscow
T +7 (0) 495 / 73 73 733
F +7 (0) 495 / 73 73 732
info@daichi.ru

Poland:

Wentoprodukt
44-100 Gliwice
T +48 (0) 32 33 13 424
F +48 (0) 32 72 97 653 75
biuro@wentoprodukt.pl

Switzerland:

Anson AG Zürich
CH-8055 Zürich
T +41 (0) 44 / 46 11 111
F +41 (0) 44 / 46 13 111
info@anson.ch

Ventra Technik AG
CH-8599 Salmsach
T +41 (0) 71 / 46 11 447
F +41 (0) 71 / 46 11 448
ventra@bluewin.ch

United Kingdom:

Wolter (UK) Ltd.
GB-Leicestershire LE65 1AL
T +44 (0) 1530 / 412 473
info@wolteruk.com

Middle East and North Africa

Israel:

Pach Taas (Ashkelon) Ltd.
IL-78100 Ashkelon
T +972 (0) 8 / 67 19 770
F +972 (0) 8 / 67 19 771
info@pachtaas.com

UAE, Qatar, Lebanon, Jordan, Saudi Arabia:

Energy International Co.
UAE-Sharjah, P.O. Box 3562
T +971 (0) 6 / 53 43 477
F +971 (0) 6 / 53 43 756
fsalibi@energysgh.ae

Energy International Co.
P.O. Box 45217 Abu Dhabi, UAE
T +971 (2) 67 11 10 8
F +971 (2) 67 69 669
amohsen@energyintl.ae

Energy International Co.(Dubai-Sharjah)
P.O. Box 3562 Sharjah, UAE
T +(971) 65 34 34 77
F +(971) 65 34 37 56
fsalibi@energysgh.ae

Energy International Corporation
Malaz Area, Siteen Highway Beside BANK
ALBILAD Riyadh, Saudi Arabia
T +(966) 14 15 39 59
msheet@energyintl.com

Energy International Corporation
P.O. Box 37364 Doha, Qatar
T +(974) 45 80 765
F +(974) 45 81 126
aassi@energyintl.com

Energy International
234 Balbesi Bld 2nd floor Al-Madinah,
Al Munawarah St Amman, Jordan
T +(962) 65 67 19 15
F +(962) 65 67 19 16
eabuzahra@energyintl.com

Energy International & Engineering
Mar Roukoz Center-Block B - First Floor,
Hazmieh, Lebanon
T +(961) 54 50 61 0
F +(961) 54 51 16 9
bsaab@energyintl.com

Asia

China:

Dongguan Wolter Chemco Ventilation Ltd.
Chemco Building, Miao Bian Wang Ind.
Shipai, Dongguan City, Guangdong
T +(86) 0 769 / 8655 7298
F +(86) 0 769 / 8655 7278
info@wolterfans.com

Taizhou Wolter Ventilation Co. Ltd.
Hengjie, Luqiao District
Taizhou City, Zhejiang
T +(86) 0 576 / 26 22 666 (26 52 888)
F +(86) 0 576 / 26 56 830

Hongkong:

Wolter Asia Ltd.
Hong Kong
T +(852) 0 2456 0198
F +(852) 0 2456 0290
info@wolter.com.hk

Taiwan:

Waxlink International Co., Ltd.
8F-2 No.218 Roosevelt Rd., Sec.6
Taipei, Taiwan
T +(886) 02 / 8932 1196
F +(886) 02 / 8932 1197
waxlink@mail.waxlinktw.com

India:

Wolter Ventilators India Pvt. Ltd.
867 D, Block-A, Sushant Lok, Phase-I,
Gurgaon - 122009 (Haryana)
T +(91) 124 2577797, 4261001-3
sales@wolterindia.in

Indonesia:

PT Lung Makmur Abadi.
Kawasan Pergudangan Taman Tekno Blok
M/16, Serpong-Tangerang 15310
T +(62) 0 21 / 7588 2609 ext 104
F +(62) 0 21 / 7588 2610
lma.wolter@gmail.com

Korea:

Kaceco-Wolter
14-1, Dang-dong, Gunpo-shi, Gyeonggi-do
T +(82) 0 31 / 4773 104
F +(82) 0 31 / 4773 132
wolter@kaceco.com / info@kaceco.com

Malaysia:

Vibrantech (M) Sdn Bhd.
47200 Petaling Jaya Selangor, Malaysia
T +(603) 0 7847 3500
Fax +(603) 0 7847 3380
sales@vibrantech-sb.com

Singapore:

Wolter Pte. Ltd.
SG-569738 Singapore
T +(65) 0 63 / 52 95 48
F +(65) 0 63 / 52 95 47
info@wolterfans.com.sg

Sri Lanka:

Sirocco Air Technologies (Pvt) Ltd.
28/12, Gemunu Mawatha, Kotuwegoda,
Rajagiriy, Sri Lanka
T +(94) 11 7 392 010
F +(94) 11 7 392 015
suren@sairt.com

Thailand:

Wolter Ventilation Co., Ltd.
Thamai Kratumban Samutsakorn 74110
Thailand
T +(66) 0 3486 6555
F +(66) 0 3486 6599
natiphan@wolterfan.com

Australia

The Sydney Fan Company.

NSW 2147, Sydney, Australia
T +(61) 0 2 / 9624 4000
F +(61) 0 2 / 9624 4100
sales@thesydneyfancompany.com

Wolter GmbH

Maschinen-und Apparatebau KG

Am Wasen 11
D-76316 Malsch / Germany
T +49 (0) 72 04 / 92 01 0
F +49 (0) 72 04 / 92 01 11
www.wolter.eu
info@wolter.eu





Air In Motion

Reference: **A09-F**, November 2024, Printed in November, 2024

Dongguan Wolter Chemco Ventilation Ltd. (Wolter Asia)

Shipai, Dongguan City, Guangdong Province, P.R.China

Tel. (+86)769 8655 7298, Fax (+86)769 8655 7278

www.wolterfans.com

info@wolterfans.com

wolter 