

MODEL EA-681

Extruded Aluminum Louver • 6" Deep • 35° Straight Blades • Combination Adjustable

Standard Materials and Construction

FRAME: .081" thk. (nominal) extruded aluminum, 6063-T52/T6 alloy. Channel type.

BLADES: Stationary blades are made from .081" thk. (nominal) extruded aluminum 6063-T52/T6 alloy. Adjustable blades are made from .125" thk. (nominal) extruded aluminum 6063-T52/T6 alloy. Blades are approximately 4½" on centers.

LOUVER FACE: Full width sill with head and blades contained within jamb.

SHAFT: .50" dia. aluminum "Pin-Lock" rod.

LINKAGE: Extruded aluminum, concealed in the channel out of the airstream. The pivots, which rotate in Celcon bearings, are .50" dia. plated and machined steel. The pivot is locked to the ¼" dia. aluminum linkage rod by a ¼ - 20 set screw with epoxy locking patch.

SEALS: Extruded silicone rubber seals at blade edge. Foam on bottom blade. Stainless steel at jambs.

SCREEN: (When indicated, in a removable frame)

- or- Insect screen 1⅞ aluminum mesh, .011" dia.,
- or- ½" sq. mesh intermediate double crimped aluminum wire, .063" dia.

FINISH: Mill.

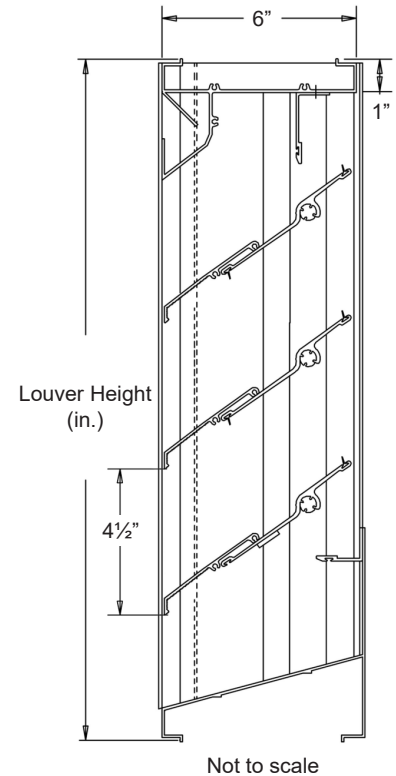

Options

Finishes - Enamels, Epoxies, etc.

Other screens available.

Actuators - Electric, Pneumatic, Manual, etc.

Notes

1. Nominal deductions will be made to the opening size given.
2. Approximate shipping weight is 5.0 lbs./sq.ft.

Louver Sizes

Min Panel	Max Single Panel
12"W x 16"H	48"W x 96"H

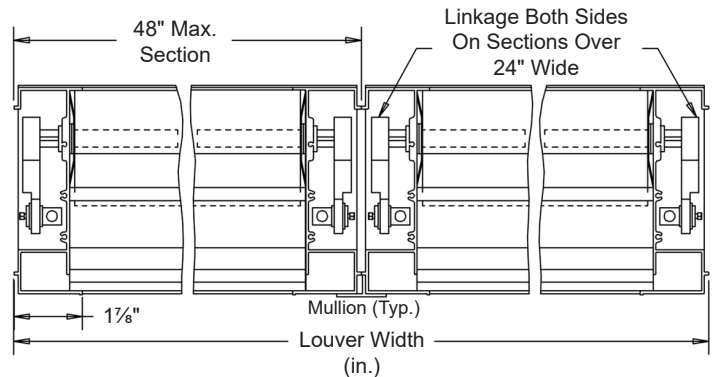
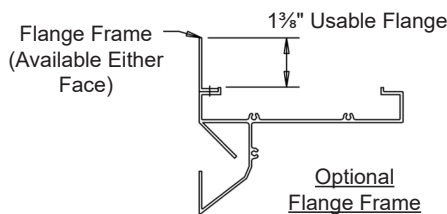

Item #	Qty	Width	Height	Width	Height	Mullion	Type	Location	Union Made
		Opening Size		Louver Size			Screens		
Arch. / Eng.:						EDR:		ECN:	Job:
Contractor:									
Project:						Date:		DWN:	DWG:



Performance Data

Pressure Drop: .145 in. w.g. at 981 fpm (intake)
 Free Area: 8.38 sq.ft. = 52% for 48"W x 48"H sample tested in accordance with AMCA Standard 500-L.
 Beginning Point of Water Penetration: 981 fpm

Ratings do not include the effects of a screen

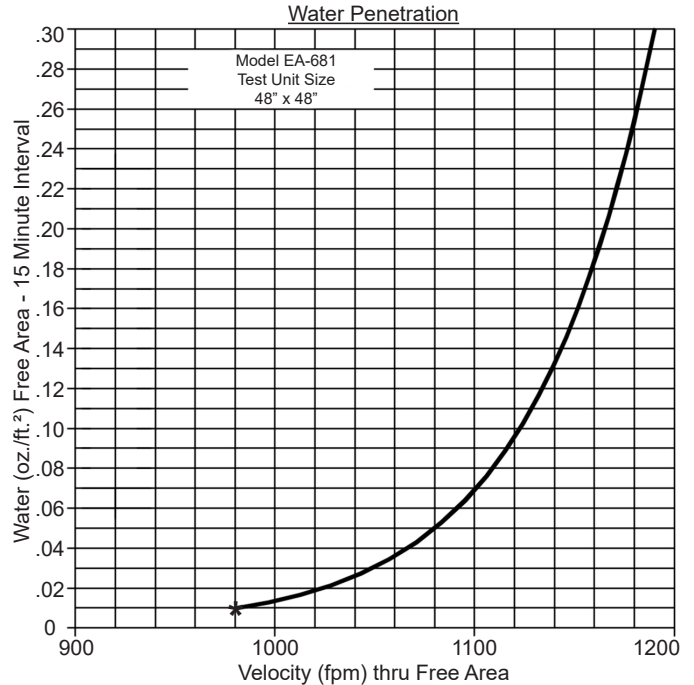
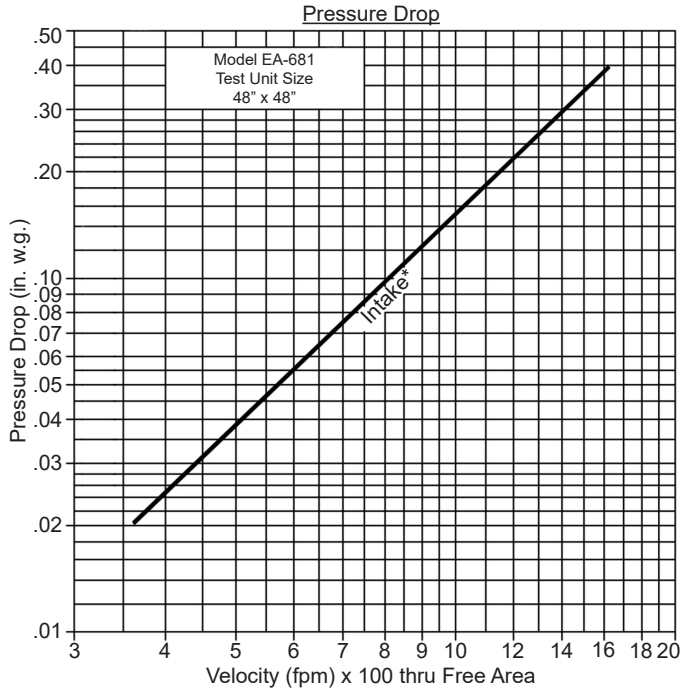

981 (FPM) Beginning Point of Water Penetration.

*Intake air converted to standard air density. Tested to AMCA Standard 500-L, Figure 5.5.

		Width (in.)						
		12"	18"	24"	30"	36"	42"	48"
Height (in.)	12"	.14	.24	.34	.45	.56	.65	.76
	24"	.66	1.15	1.65	2.14	2.64	3.13	3.63
	36"	1.04	1.82	2.60	3.38	4.16	4.94	5.71
	48"	1.55	2.72	3.88	5.04	6.21	7.37	8.38
	60"	2.07	3.63	5.18	6.74	8.29	9.85	11.40
	72"	2.45	4.29	6.13	7.97	9.81	11.65	13.49
	84"	2.97	5.19	7.42	9.64	11.87	14.09	16.31
	96"	3.49	6.10	8.72	11.34	13.95	16.57	19.18

Air Leakage with adjustable blade in closed position with a seating torque of 6.25 in.lb./sq.ft. of Louver Face Area. Leakage is based on a test of a 48" x 48" louver. Air leakage (Louver Installation Position, Intake) is per AMCA Standard 500 Procedure Fig. 5.5.

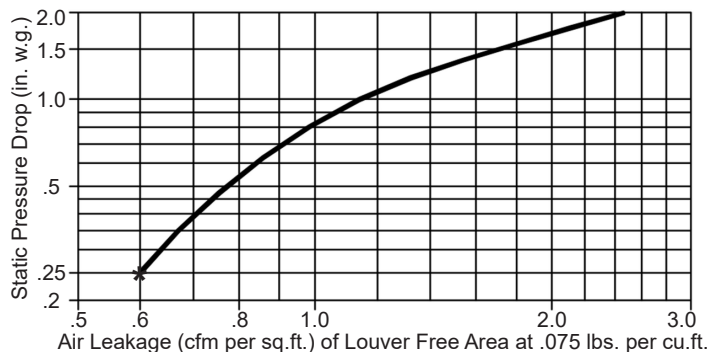

Arrow United Industries certifies that the Model EA-681 shown herein is licensed to bear the AMCA seal. The ratings shown are based on tests and procedures performed in accordance with AMCA Publication 511 and comply with the requirements of the AMCA Certified Ratings Program. The AMCA Certified Ratings Seal applies to Air Performance and Water Penetration Ratings only.