

AS2D99HS

STANDARD MATERIALS AND CONSTRUCTION

FRAME: .063" thick (nominal) extruded aluminum, 6063-T52/T6 alloy

BLADE: .063" thick (nominal) extruded aluminum, 6063-T52/T6 alloy.
Blades approximately 1" on centers.

LOUVER FACE: Head and blades are contained within jambs. Sill contains jamb.

DRAIN SILL PAN: .060" thick (nominal) formed aluminum.

SCREEN: (When indicated, in a removable frame.)

- 1/2" flattened aluminum (.051" thick),
- or- 1/2" sq. mesh, intermediate double-crimped aluminum wire, .063" dia.,
- or- 19/16 mesh, .011" dia. aluminum wire, insect screen.

FINISH: Mill

OPTIONS

Finish - Baked Enamel, Kynar, Anodize

NOTES

1. Nominal deductions will be made to the opening size given.
2. Approximate shipping weight is 4.0 lbs./sq.ft.

LOUVER SIZES

Min Panel	Max Single Panel
12"W x 12"H	60"W x 96"H

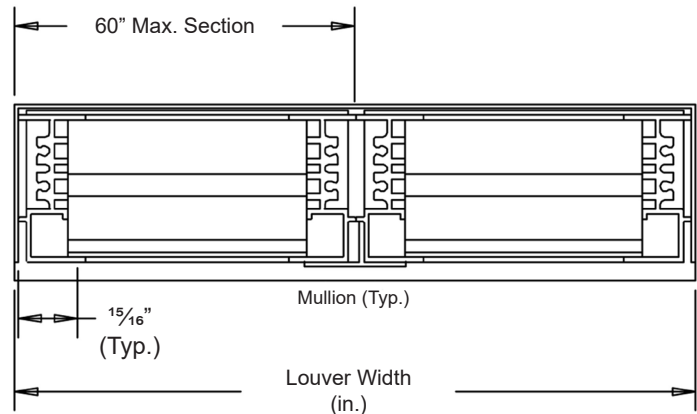
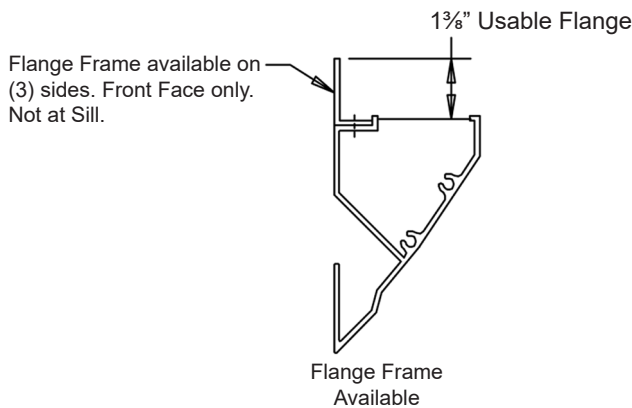
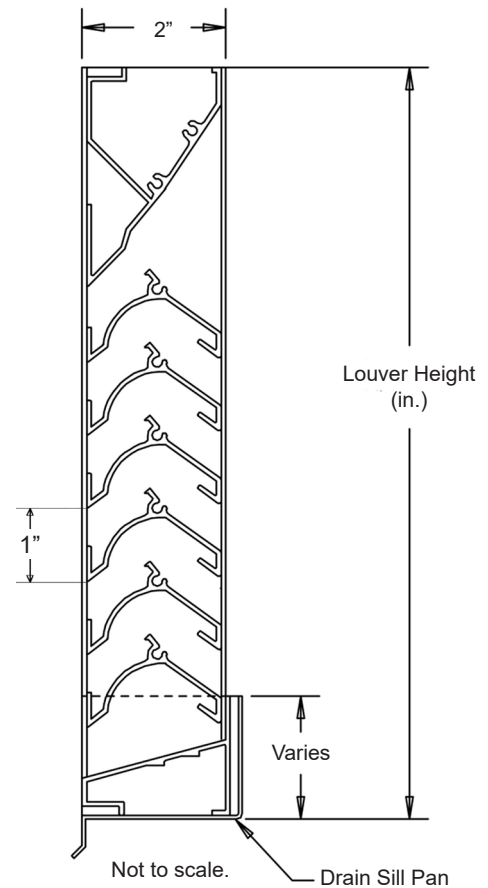

In the interest of product development, Airline Louvers reserves the right to make changes without notice.

										
Item #	Qty	Width	Height	Width	Height	Mullion	Type	Location		
		Opening Size		Louver Size			Screens			Union Made
Arch. / Eng. :						EDR:		ECN:		Job:
Contractor:										
Project:						Date:		DWN:		DWG:

AS2D99HS

PERFORMANCE DATA

Pressure Drop: .38 in. w.g. at 1000 fpm (intake)

Free Area: 6.93 sq.ft. = 43.3% for 48"W x 48"H sample tested in accordance with AMCA Standard 500-L.

Class "A" Rating with 99.7% efficiency at 3 in. rain fall at intake velocity of 435 fpm (3,015 cfm) at wind speed of 29 mph.

Class "A" Rating with 99.2% efficiency at 8 in. rain fall at intake velocity of 240 fpm (1,663 cfm) at wind speed of 50 mph.

Testing based on 48" x 48" based on AMCA Standard 500-L.

Ratings do not include effects of a screen.

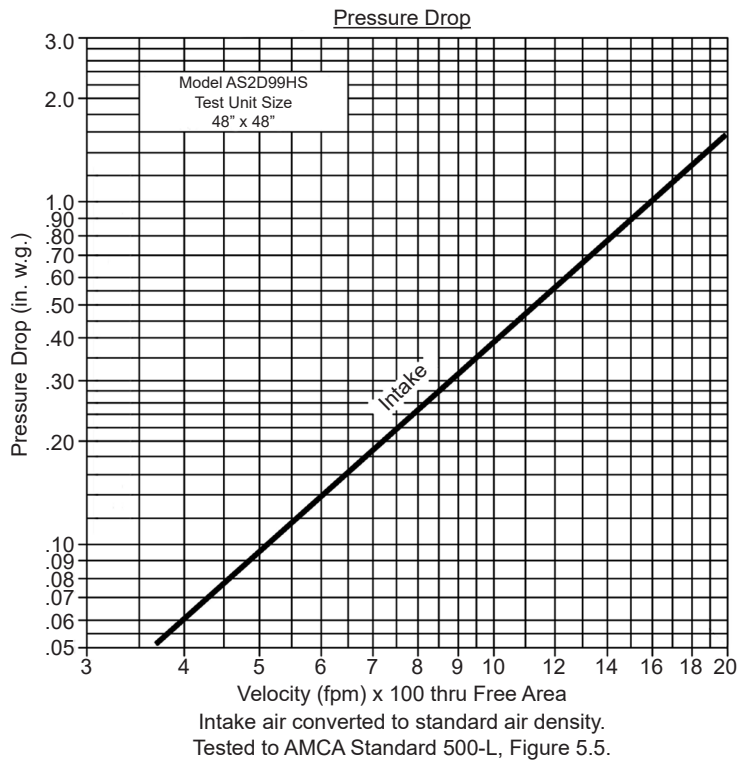

Free Area (sq.ft.)

		Width (in.)								
		12"	18"	24"	30"	36"	42"	48"	54"	60"
Height (in.)	12"	.28	.45	.62	.79	.95	1.12	1.29	1.46	1.62
	24"	.71	1.13	1.55	1.97	2.39	2.81	3.23	3.65	4.07
	36"	1.14	1.81	2.48	3.15	3.83	4.50	5.17	5.84	6.52
	48"	1.56	2.49	3.41	4.34	5.26	6.19	6.93	8.04	8.96
	60"	1.99	3.17	4.35	5.52	6.70	7.88	9.56	10.23	11.41
	72"	2.42	3.85	5.28	6.71	8.14	9.56	10.99	12.42	13.85
	84"	2.85	4.53	6.21	7.89	9.57	11.25	12.93	14.62	16.30
96"	3.27	5.21	7.14	9.07	11.01	12.94	14.88	16.81	18.74	

AS2D99HS

Wind Driven Rainwater Penetration Test
 Conducted to AMCA Standard 500-L.
 Test size 1m x 1m (39.7" x 39.7") core area, nominal.
 Louver Free Area 5.24 square feet.

Core Ventilation (m/s)	0.0	0.5	1.0	1.5	2.0	2.5	3.0	3.5	Rain Fall / MPH
FPM	0	133	212	296	383	491	581	668	3 in. / hr. rain fall and 29 mph Velocity
Free Area Ventilation (cfm)	0	1,431	2,279	3,188	4,128	5,291	6,259	7,192	
Free Area Velocity (fpm)	-	273	435	608	788	1,010	1,194	1,373	
Effective Rating Class	A	A	A	B	B	C	D	D	8 in. / hr. rain fall and 50 mph Velocity
FPM	0	117	195	280	386	461	596	695	
Free Area Ventilation (cfm)	0	1,261	2,095	3,013	4,157	4,964	6,123	7,483	
Free Area Velocity (fpm)	-	240	400	575	793	947	1,169	1,428	
Effective Rating Class	A	A	B	B	B	C	C	D	

Wind Driven Rain Penetration Classifications

Class	Effectiveness %
A	100 to 99%
B	98.9% to 95%
C	94.9% to 80%
D	Below 80%

Discharge Loss Coefficient Classifications

Class	Discharge Loss Coefficient
1	0.4 and above
2	0.3 to 0.399
3	0.2 to 0.299
4	0.199 and below

Discharge Coefficient

 Intake Cd= 0.19 (Class 4)

Class 1 Loss Coefficient has the least resistance to airflow.

1. Core area is the front opening of a louver assembly with the blades removed.
2. Core area velocity is the airflow rate through the louver divided by the core area (39.37" x 39.37").
3. Free area is the minimum area through which air can pass. It is determined by multiplying the sum of the minimum distance between intermediate blades, top blade and head, bottom blade and sill, by the minimum distance between jambs.
4. Discharge loss coefficient is calculated by dividing a louver actual airflow rate vs. a theoretical airflow for the opening, providing an indication of the louver air flow characteristics.



Airline Louvers certifies that the Model AS2D99HS shown herein is licensed to bear the AMCA seal. The ratings shown are based on tests and procedures performed in accordance with AMCA Publication 511 and comply with the requirements of the AMCA Certified Ratings Program. The AMCA Certified Ratings Seal applies to Air Performance and Wind Driven Rain Ratings only.