

Application

The SEVCD-23 is a severe environment 316SS low leakage control damper with 316SS stainless steel 3V blades. This model is intended for application in low to medium pressure and velocity systems. Low profile head and sill used on sizes less than 17 in. (432 mm) high.

The SEVCD-23 is also IECC (International Energy Conservation Code) compliant with a leakage rating of 3 cfm/ft² @ 1 in. wg (55 cmh/m² @ .25 kPa) or less.

Damper Ratings

Pressure

Up to 5 in. wg (1.2 kPa) pressure differential

Velocity

Up to 3000 fpm (15.2 m/s)

Leakage

Class 1A @ 1 in. wg (.25 kPa)
Class 1 @ 5 in. wg (1.2 kPa)

Temperature

Up to 250°F (121°C)

Construction

	Standard	Optional
Frame Material	316SS	-
Frame Thickness	16 ga. (1.5 mm)	-
Frame Type	5 in. x 1 in. (127 mm x 25 mm) hat channel	Single Flange, Reverse Flange, Double Flange
Blade Action	Opposed	Parallel
Blade Material	316SS	-
Blade Material Thickness	16 ga. (1.5 mm) equivalent	-
Blade Type	3V	-
Linkage	316SS	-
Axle Bearings	316SS	-
Axle Material	½ in. dia. 316SS	-
Blade Seals	TPE	Silicone
Jamb Seals	316SS	-

Size Limitations

W x H	Minimum Size	Maximum Size	
		Single Section	Multi-Section
Inches	6 x 6	48 x 74	Unlimited
mm	152 x 152	1219 x 1880	



*W&H dimension furnished approximately ¼ in. (6 mm) undersize.

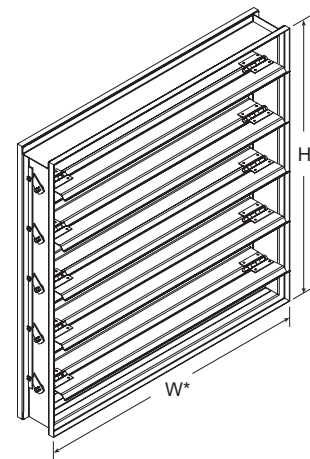

Notes:

- Low profile head and sill are used on sizes less than 17 in. (432 mm) high
- Electric actuator and manual quadrant available. Factory supplied actuators are sized for 1500 fpm (7 m/s) and fully closed differential pressure of 2 in. wg (.5 kPa). Contact factory for actuator sizing on applications exceeding those limits.
- In applications where airflow could be uneven, such as a discharge fan, it is imperative to verify that at no point the maximum velocity exceeds the damper's cataloged velocity.
- Blades must be horizontal for either horizontal or vertical mount. If you need vertical blades, see VCD-23V model.

Blade Operation

Parallel blade operation - this configuration requires the damper blades to rotate in the same direction, parallel to one another.

Opposed blade operation - adjacent damper blades rotate opposite one another.

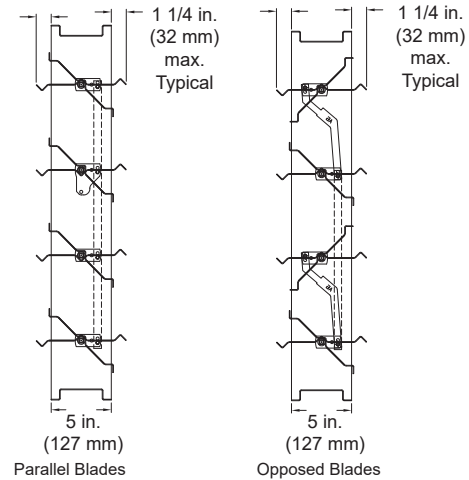

Options and Accessories

- Actuator: pull chain, manual quadrant, variety of 24V, 120V actuators
- Actuator mounting; external, external kit, and internal
- Clean wrap
- [NEMA enclosures](#)
- [OCI \(Open Closed Indicator\)](#)
- [Retaining angles](#)
- [Transformers](#)

Frame Options

Channel Frame

The channel frame option is designed for in-duct or slip-in installation. Dampers with external actuators can be rotated in the field 180 degrees to change from right hand to left hand drive (not recommended on parallel blade dampers).

Scan the QR code or click on the link “More Info” for more information on single flange, reverse flange and double flange.



[MORE INFO](#)

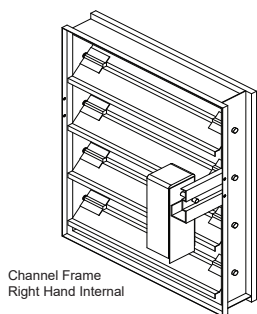

Channel Frame
Right Hand Internal

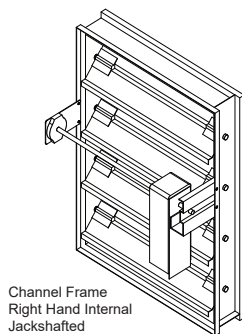

Channel Frame
Right Hand Internal
Jackshafted

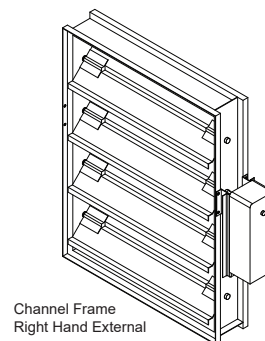

Channel Frame
Right Hand External

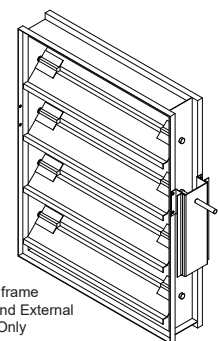

Channel frame
Right Hand External
Bracket Only

Pressure Drop



Greenheck Fan Corporation certifies that the model SEVCD-23 shown herein is licensed to bear the AMCA Seal. The ratings shown are based on tests and procedures performed in accordance with AMCA Publication 511 and comply with the requirements of the AMCA Certified Ratings Programs. The AMCA Certified Ratings Seal applies to Air Leakage and Air Performance ratings.

AMCA 5.2

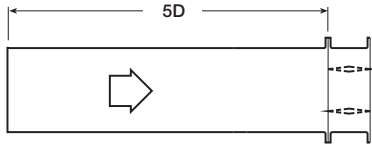

12 in. x 12 in. (305 mm x 305 mm)

Velocity (fpm)	Pressure Drop (in. wg)
500	0.01
1000	0.05
1500	0.11
2000	0.19
2500	0.29
3000	0.41
3500	0.55
4000	0.72

24 in. x 24 in. (610 mm x 610 mm)

Velocity (fpm)	Pressure Drop (in. wg)
500	0.01
1000	0.03
1500	0.06
2000	0.10
2500	0.16
3000	0.23
3500	0.30
4000	0.40

36 in. x 36 in. (914 mm x 914 mm)

Velocity (fpm)	Pressure Drop (in. wg)
500	0.01
1000	0.02
1500	0.05
2000	0.09
2500	0.14
3000	0.19
3500	0.27
4000	0.35

12 in. x 48 in. (305 mm x 1219 mm)

Velocity (fpm)	Pressure Drop (in. wg)
500	0.01
1000	0.04
1500	0.08
2000	0.15
2500	0.22
3000	0.32
3500	0.43
4000	0.56

48 in. x 12 in. (1219 mm x 305 mm)

Velocity (fpm)	Pressure Drop (in. wg)
500	0.01
1000	0.03
1500	0.07
2000	0.12
2500	0.18
3000	0.26
3500	0.36
4000	0.47

AMCA 5.3

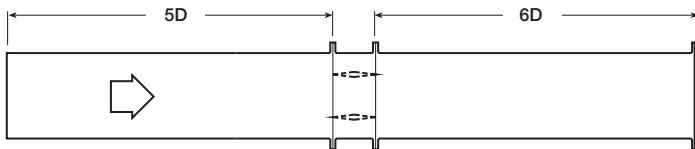

12 in. x 12 in. (305 mm x 305 mm)

Velocity (fpm)	Pressure Drop (in. wg)
500	0.01
1000	0.03
1500	0.08
2000	0.13
2500	0.20
3000	0.29
3500	0.40
4000	0.51

24 in. x 24 in. (610 mm x 610 mm)

Velocity (fpm)	Pressure Drop (in. wg)
500	0.01
1000	0.02
1500	0.04
2000	0.07
2500	0.11
3000	0.16
3500	0.21
4000	0.28

36 in. x 36 in. (914 mm x 914 mm)

Velocity (fpm)	Pressure Drop (in. wg)
500	0.01
1000	0.02
1500	0.03
2000	0.06
2500	0.09
3000	0.13
3500	0.19
4000	0.25

12 in. x 48 in. (305 mm x 1219 mm)

Velocity (fpm)	Pressure Drop (in. wg)
500	0.01
1000	0.03
1500	0.07
2000	0.12
2500	0.18
3000	0.26
3500	0.36
4000	0.46

48 in. x 12 in. (1219 mm x 305 mm)

Velocity (fpm)	Pressure Drop (in. wg)
500	0.01
1000	0.03
1500	0.06
2000	0.10
2500	0.16
3000	0.22
3500	0.30
4000	0.39

AMCA 5.5

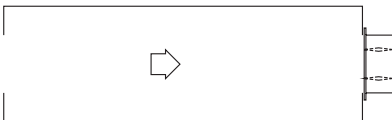

12 in. x 12 in. (305 mm x 305 mm)

Velocity (fpm)	Pressure Drop (in. wg)
500	0.03
1000	0.13
1500	0.30
2000	0.53
2500	0.82
3000	1.19
3500	1.62
4000	2.10

24 in. x 24 in. (610 mm x 610 mm)

Velocity (fpm)	Pressure Drop (in. wg)
500	0.03
1000	0.12
1500	0.26
2000	0.47
2500	0.75
3000	1.04
3500	1.41
4000	1.90

36 in. x 36 in. (914 mm x 914 mm)

Velocity (fpm)	Pressure Drop (in. wg)
500	0.02
1000	0.10
1500	0.22
2000	0.40
2500	0.62
3000	0.90
3500	1.23
4000	1.62

12 in. x 48 in. (305 mm x 1219 mm)

Velocity (fpm)	Pressure Drop (in. wg)
500	0.03
1000	0.14
1500	0.32
2000	0.57
2500	0.90
3000	1.29
3500	1.76
4000	2.30

48 in. x 12 in. (1219 mm x 305 mm)

Velocity (fpm)	Pressure Drop (in. wg)
500	0.03
1000	0.12
1500	0.28
2000	0.49
2500	0.77
3000	1.12
3500	1.53
4000	2.01

Leakage

Air leakage is based on operation between 32°F (0°C) and 120°F (49°C).

Tested for leakage in accordance with ANSI/AMCA Standard 500-D, Figure 5.5.

Tested for air performance in accordance with ANSI/AMCA Standard 500-D, Figures 5.2, 5.3 and 5.5.

Torque

Data are based on a torque of 7.0 in. lb/ft² (0.79 N·m) applied to close and seat the damper during the test.

SEVCD-23	Leakage Class		
Maximum Damper Width	1 in. wg (0.25 kPa)	4 in. wg (1 kPa)	5 in. wg (1.2 kPa)
48 in. (1219 mm)	1A	1	1



Greenheck Fan Corporation certifies that the model SEVCD-23 shown herein is licensed to bear the AMCA Seal. The ratings shown are based on tests and procedures performed in accordance with AMCA Publication 511 and comply with the requirements of the AMCA Certified Ratings Programs. The AMCA Certified Ratings Seal applies to Air Leakage and Air Performance ratings.

*Leakage Class Definitions

The maximum allowable leakage is defined by AMCA as the following:

- Leakage Class 1A - 3 cfm/ft² @ 1 in. wg (class 1A is only defined at 1 in. wg).
- Leakage Class 1
 - 4 cfm/ft² @ 1 in. wg
 - 8 cfm/ft² @ 4 in. wg
 - 11 cfm/ft² @ 8 in. wg
 - 12.6 cfm/ft² @ 10 in. wg

Velocity Limitations

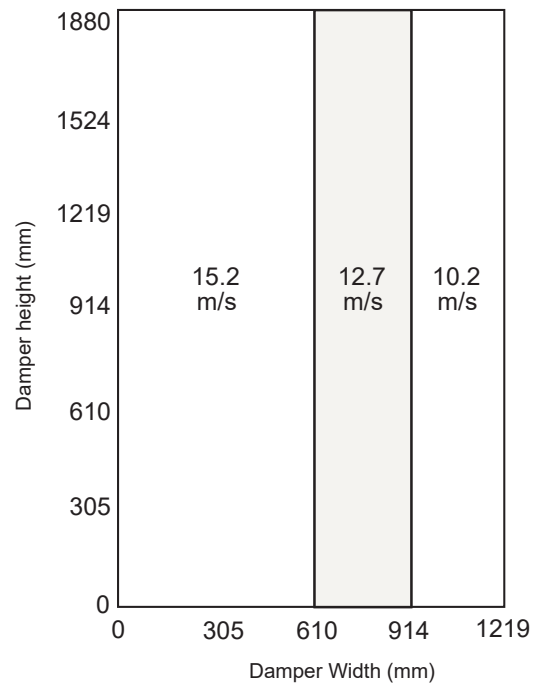
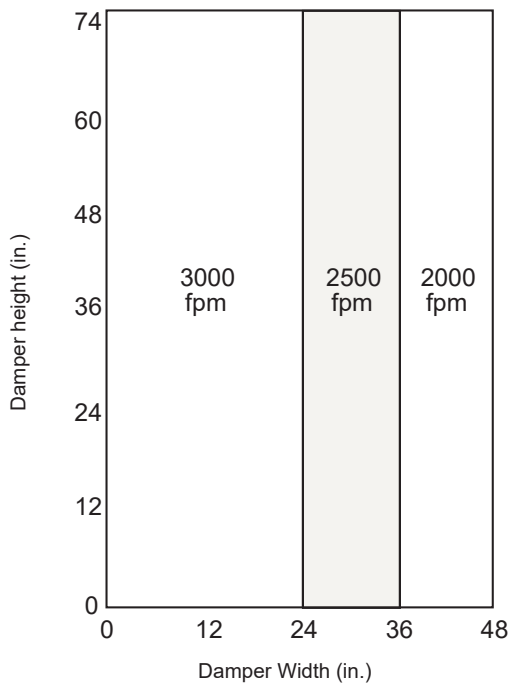

Temperature Limitations

Blade Seal	Temperature Range
TPE	-10°F to 200°F (-23°C to 93°C)
Silicone	-40°F to 250°F (-40°C to 121°C)

Space Envelopes

On dampers less than 18 in. (457 mm) high, actuators may also require clearances above and/or below the damper frame. “B” and “T” dimensions are worst case clearance requirements for some dampers less than 18 in. (457 mm) high. All damper sizes under 18 in. (457 mm) high do not require these worst case clearances. If space availability above or below the damper is limited, each damper size should be individually evaluated.

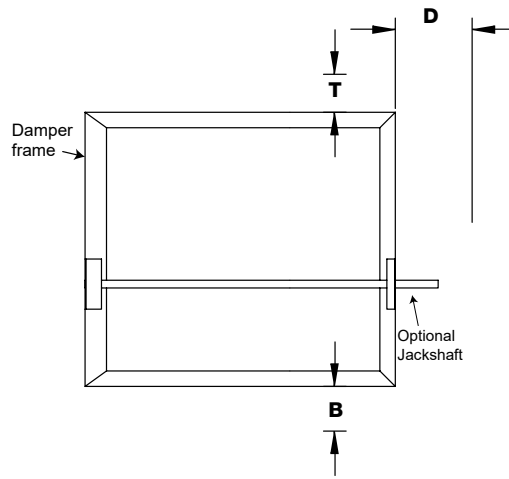

Actuator Type/Model	Height Inches (mm)	T Inches (mm)	B Inches (mm)	D Inches (mm)
AFBUP (-S) and FSNF Series, Belimo MSxx20 Series, Honeywell	≥6 to <10 (≥152 to <254)	0	12¾ (324)	6¼ (159)
	≥10 to <18 (≥254 to <457)	0	2 (51)	6¼ (159)
	≥18 (457)	0	0	6¼ (159)
FSLF, LF and TFB Series, Belimo	≥6 to <10 (≥152 to <254)	0	3½ (89)	6¼ (159)
	≥10 (≥254)	0	0	6¼ (159)
MSxx04 & MSxx09 Series, Honeywell	≥6 to <9 (≥152 to <229)	0	4¾ (121)	6¼ (159)
	≥9 (229)	0	0	6¼ (159)
MS75xx Series, Honeywell	≥6 to <10 (≥152 to <254)	0	12¾ (324)	6¼ (159)
	≥10 to <18 (≥254 to <457)	0	7 (178)	6¼ (159)
	≥18 (457)	0	0	6¼ (159)
GRD and GVD Series, Siemens	≥6 to <10 (≥152 to <254)	0	12¾ (324)	6¼ (159)
	≥10 to <18 (≥254 to <457)	0	2 (51)	6¼ (159)
	≥18 (457)	0	0	6¼ (159)
GJD Series, Siemens	≥6 to <10 (≥152 to <254)	0	3½ (89)	6¼ (159)
	≥10 to <18 (≥254 to <457)	0	0	6¼ (159)
	≥18 (457)	0	0	6¼ (159)

Actuator Mounting

Actuators may be installed at the factory, shipped loose with the necessary linkage and brackets for mounting or field supplied. For more detail information on actuator mounting, click on link below or scan QR code.



[ACTUATOR MOUNTING](#)

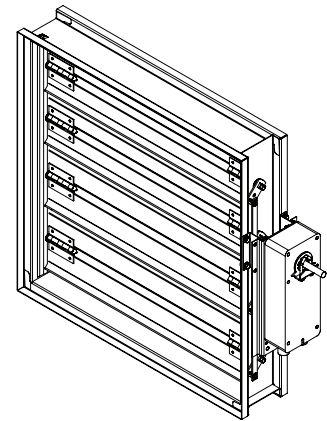

Non-jackshaft external right

Mounting Clearance

This drawing depicts the worst case clearance requirements for an actuator with a jackshaft.

Internal mount only Actuator model	A	B	C
All except - EFB & EFCX Series	7¼ in. (197 mm)	3¾ in. (95 mm)	5⅝ in. (136.5 mm)
EFB & EFCX Series	8½ in. (216 mm)	6 in. (152 mm)	8½ in. (216 mm)

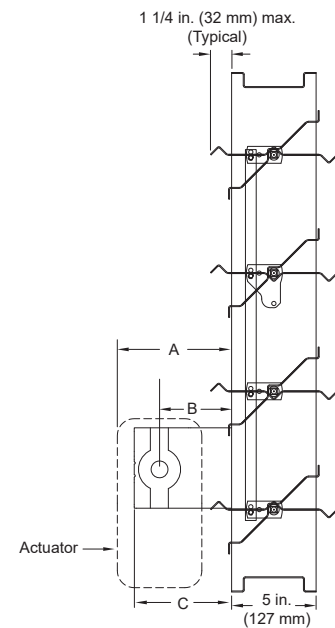

Multi-Section Dampers

Dampers larger than the maximum single section size, will be made up of a multiple of equal size sections.

NOTE: Dampers larger than 48 in. x 74 in. (1219 mm x 1880 mm) are not intended to be structurally self supporting. Refer to IOM document #463384 for structural support requirements on multi-section assemblies.

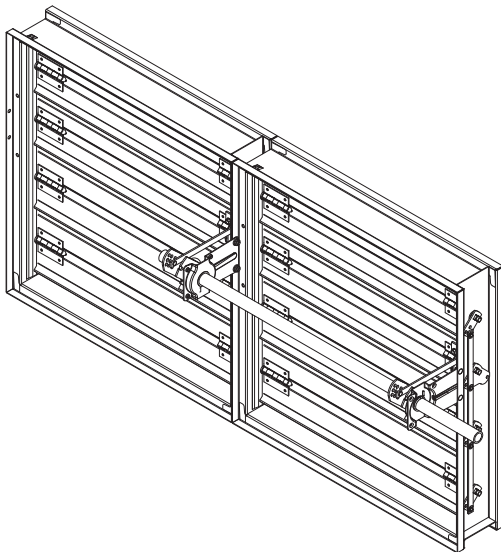

2 section example shows single jackshaft driving multiple sections

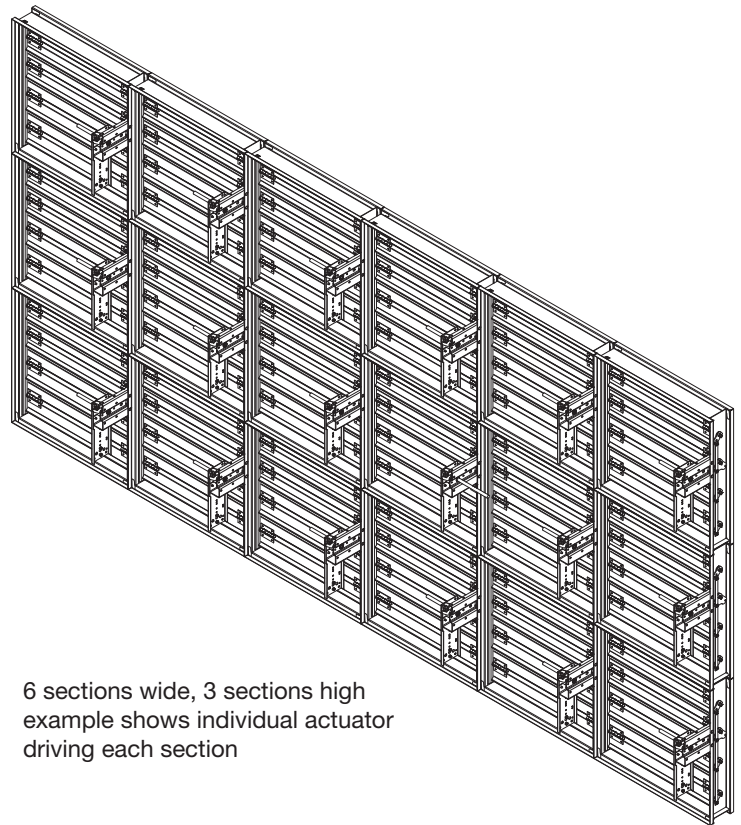

6 sections wide, 3 sections high
example shows individual actuator driving each section

Document Links



[INSTALLATION](#)



[CATALOG](#)



[SELECTION GUIDE](#)



[SPECIFICATIONS](#)



[WARRANTY](#)